



# CONTENTS

---

1.0 IMPORTANT USER INFORMATION	2
2.0 SAFETY	6
3.0 MOUNTING THE MACHINE	14
4.0 ROAD TRAVEL	20
5.0 PARTS OVERVIEW	23
6.0 OPERATION AND ADJUSTMENT	26
7.0 SETTING UP FOR WORK	34
8.0 FIELD OPERATION	37
9.0 DISMOUNTING THE MACHINE	38
10.0 GENERAL MAINTENANCE	40
11.0 LANDWHEEL MAINTENANCE	46
12.0 TOOLBAR MAINTENANCE	48
13.0 ROW UNIT MAINTENANCE	49
14.0 LOADING WORK	50
15.0 DECOMMISSIONING AND DISPOSAL	51
16.0 TECHNICAL DATA	52
17.0 SEED RATE CALCULATIONS	53
18.0 SPACING CHARTS	54

# 1.0 IMPORTANT USER INFORMATION

## 1.1 INFORMATION REGARDING THE OPERATOR MANUAL

This operator manual contains important information regarding the handling of the machine and the unit. Observing all specified safety instructions and handling instructions is a prerequisite for safe work.

Carefully read this operator manual before starting any work. The operator manual is a part of the product and must be kept in the immediate vicinity of the machine or unit and must be accessible to the personnel at all times. An incomplete or illegible operator manual must be immediately replaced by a new operator manual.

This operator manual is part of the machine and must be handed to the buyer when the machine is resold. The operator manual is also available in other languages.

Supplementary to the operator manual, the legal, general and other binding regulations regarding the prevention of accidents and protection of the environment must be heeded and instructed.

## 1.2 VALIDITY OF THE OPERATOR MANUAL

This operator manual only applies to machines with Seven row units fitted. All chapters in this operator manual are relevant for the series mentioned.

## 1.3 LOCATION INFORMATION IN THE OPERATOR MANUAL

The location information front, rear, left and right always refers to the direction of motion.

## 1.4 PRE-DELIVERY AND INSTALLATION

Before delivery Stanhay Webb Ltd or their dealer, will undertake certain activities when supplying a new machine. This pre delivery inspection will ensure that the machine delivered is:

- Correct to order requirements fully assembled with all options required, and ready for use.
- The delivery procedure will provide you the customer, with comprehensive instruction in the basic principles of operation of the product and of its maintenance in addition to the generalised information contained within this manual.
- These instructions will cover controls, daily and periodic maintenance and safety precautions.
- It is the owners responsibility to ensure that all persons concerned with the operation of the machine are present for, or informed of this instruction.

**THE STANHAY TEAM WISHES YOU A SUCCESSFUL SEASON WITH YOUR NEW MACHINE.**

# 1.0 IMPORTANT USER INFORMATION

---

## 1.5 USE AS INTENDED

The Seven precision seeder is suitable for drilling various types of small seed. The precision seeder is exclusively intended for attachment to a tractor in accordance with the requirements and may only be used for agricultural purposes within the scope of application described in this manual.

Using the machine for any other purpose or making unauthorised changes, the use of unauthorised spare parts, accessories or auxiliaries shall be considered contrary to the intended use.

The manufacturer is not liable for any damages resulting from this; the risk is solely with the user.

The precision seeder may only be used by authorised persons who have been introduced to the machine functions.

The accident prevention regulations as well as other safety, occupational health and road traffic regulations must be adhered to at all times when using the machine.

The operator manual enclosed with the precision seeder forms an integral part of the machine. The machine is exclusively intended to be used in accordance with this operator manual. Any use beyond the functions described in the operator manual can lead to serious personal injuries as well as machine damage.

The information regarding operation, service and safe handling, as specified by the manufacturer in this operator manual and in the form of warning notes and warning labels on the precision seeder, must be observed.

Clarify any information in the operator manual that is not understood before initial machine operation. Please do not hesitate to contact the Stanhay dealers or Stanhay Webb Ltd. for any questions you may have regarding the machine or operator manual.

# 1.0 IMPORTANT USER INFORMATION

## 1.6 DECLARATION OF CONFORMITY



The manufacturer:

Stanhay Webb Ltd  
BCS House, Pinfold Road, Bourne, PE10 9HT, United Kingdom

Herewith declares under it's sole responsibility that the machine:

Machine type:	SEVEN precision seed drill
Machine number:	from S85-00001

Is compliant with the provisions of the following EU guidelines:

- Directive 2006/42/EC, Official Gazette of the EU L157/24 of 9 June 2006 (Machinery Directive)

The following harmonized standards were applied:

- EN 14018:2005+A1:2009 - Agricultural and Forestry Machinery - Seed Drills - Safety

I hereby declare that the equipment named above has been designed to comply with the relevant sections of the above referenced specifications. The unit complies with all essential requirements of the Directive.

Name: Chris Fletcher  
Position: Managing Director  
Done at: Bourne UK  
Date: 1st January 2020

# 1.0 IMPORTANT USER INFORMATION

## 1.7 PRODUCT DATA

Manufacturers Address  
 Stanhay Webb Limited,  
 BCS House,  
 Pinfold Road,  
 Bourne,  
 Lincolnshire  
 PE10 9HT  
 UK  
 Phone Number: +44 (0)8451 801480  
 info@stanhay.com  
 www.stanhay.com

## 1.8 DETAILS FOR ENQUIRIES AND ORDERS

Original spare parts and accessories approved by the manufacturer should only be used. Failure in doing this would result in invalidating the manufacturers warranty and could increase safety risks.

When ordering spare parts make sure to quote the stock code and serial number which can be found on the VIN plate which is located on the headstock of the drill.

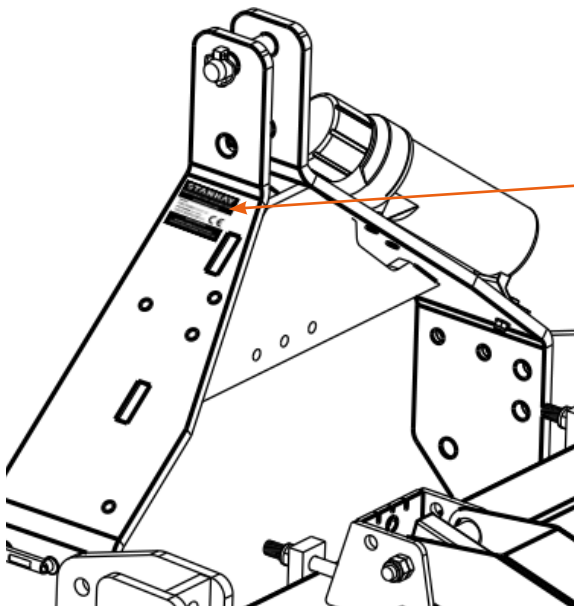

The VIN plate is a certificate and is an integral part of the drill. This must not be removed, changed or made illegible.

## 1.9 STANHAY SERVICE

Stanhay service will assist with any technical information. Information can be received at any time from a member of staff via telephone, e-mail or via the internet. For more information see contact details on the rear of this manual.

## 1.10 COPYRIGHT

This operator manual should be treated as a confidential document and its intended use is solely for the operator. Failure to abide by this may result in legal action.

## 2.0 SAFETY

### 2.1 SAFETY

This operator manual contains basic information that must be observed during installation, operation and maintenance. It is therefore absolutely necessary that this operator manual is read by personnel before initial use and operation and that it is accessible to personnel at all times. Clarify any information in the operator manual that is not understood before initial machine operation. Please do not hesitate to contact a Stanhay dealer or Stanhay Webb Ltd for any questions you may have regarding the operator manual.

The general safety instructions listed under this main topic “Safety” must be observed, together with the specific safety instructions that are located in other sections of the manual.

Apart from the information in this operator manual, the pertinent regulations for the prevention of accidents as well as other generally recognised regulations with regard to safety and occupational health must be observed.

If safety instructions are not complied with, you risk injury to yourself and others as well as damage to the environment or the machine. Non-compliance with safety instructions can also void any claims for damages.

### 2.2 EXPLANATION OF SYMBOLS

In this operator manual, warnings are marked by symbols. These notes are preceded by signal words that express the extent of the hazard. Always observe these instructions and act cautiously in order to avoid accidents, personal injuries and damage to property.

#### STRUCTURE OF A WARNING NOTICE



#### **SIGNAL WORD**

Type and source of danger  
Consequences if the warning is ignored.

- Measures to avert the danger.

#### WARNINGS



#### **DANGER!**

Identifies a danger which may lead to death or serious injury if it is not avoided.



#### **WARNING!**

Identifies a danger which may lead to death or serious injury if it is not avoided.



#### **CAUTION!**

Identifies a danger which may lead to injuries if it is not avoided.



#### **NOTE**

Indicates immediate situations which will lead to machine damage if they are not avoided.



#### **INFORMATION**

Emphasises useful tips and recommendations as well as information for an efficient and smooth operation.



#### **ENVIRONMENT PROTECTION MEASURE**

Signals measures that must be taken to avoid damage to the environment.



## 2.0 SAFETY

---

### 2.3 OPERATOR RESPONSIBILITY

The machine and/or the unit are used in commercial applications; the owner is therefore subject to the statutory requirements for safety at work. In addition to the instructions on occupational health and safety in this operator manual, you must observe the safety instructions, the instructions for the prevention of accidents and the regulations for the protection of the environment. The following should particularly be observed:

- The operator must familiarise himself with the applicable occupational health and safety requirements and, if necessary, carry out a risk assessment to determine potential risks that result from the specific working conditions at the location of the machine and/or unit.
- The operator must clearly allocate and define the responsibilities for installation, operation, maintenance and cleaning of the machine.
- The operator must ensure that the personnel handling the machine or device has read and understood the operator manual. Apart from that, he must train personnel at regular intervals and inform personnel about the dangers involved.
- The operator is also responsible for maintaining the machine and/or unit in a technically faultless state, and that the necessary inspections and the required maintenance and repair work are carried out at regular intervals so that the machine is left in a safe condition to use at all times.

### 2.4 OPERATING PERSONNEL

To avoid personal injury and material damage, persons working on this machine must meet the following minimum requirements:

- They are physically capable of controlling the machine.
- They are able to carry out the work with the machine within the scope of this operator manual in a safe manner.
- They understand the machine's mode of operation and are able to recognise and avoid the dangers associated with their work.
- They have understood the operator manual and are able to apply the information in the operator manual accordingly.
- They are a competent operator of the vehicle attached to this machine.
- If the machine is to be taken on the road then the operator must be familiar with the relevant road traffic laws in that country and hold the required driver's license/documentation. The responsibility for this rests with the operator of the machine.

The following qualifications for specific tasks are defined in the operator manual:

#### 2.4.1 INSTRUCTED PERSONNEL

An instructed person is he/she who has been instructed and where necessary trained to operate the machine. An instructed person will be made aware of the potential dangers in case of incorrect operation and has also been instructed with regard to necessary guards and protective measures. Instructed personnel include the owner and the operator of the machine.

#### 2.4.2 SPECIALIST STAFF

Due to their technical training, know-how, experience, and knowledge of the applicable regulations, specialist staff are able to carry out the assigned tasks and to recognise potential risks on their own. Specialist staff included, but not limited to, Stanhay staff and service technicians, Stanhay dealers and specialist technicians.

# 2.0 SAFETY

---

## 2.5 PERSONAL PROTECTIVE EQUIPMENT

Wearing the correct personal protective equipment when operating this machine is important and should be adhered to at all times. Missing or unsuitable personal protective equipment increases the risk of serious health problems and injuries of persons. Personal protective equipment comprises for instance:

- Protective gloves
- Safety shoes
- Protective clothing
- Reflective clothing
- Respiratory protection
- Hearing protection
- Face and eye protection when dealing with chemicals
- Wear suitable clothing - Loosely worn clothing increases the danger of getting caught or drawn into rotating parts or protruding parts. Persons may get seriously or fatally injured by this.
- Never wear rings, chains and other jewellery.
- Long hair must be tied or covered up to reduce the possibility of entanglement.
- Safety footwear.

## 2.6 SPECIAL RISKS

The following section lists the residual risks resulting from the risk analysis. Note the safety instructions listed here and the warnings in the other chapters of this operator manual in order to reduce health risks and to avoid hazardous situations.

### 2.6.1 NOISE

**DANGER!**

Risk of hearing damage due to noise! The noise level occurring in the working area may cause serious hearing damage.

- Always wear ear protection during work.

## 2.0 SAFETY

---

### 2.7 GENERAL SAFETY INSTRUCTIONS AND ACCIDENT PREVENTION

The safety advice and information given in this operator manual, the applicable national regulations concerning accident prevention and any applicable internal work, operating and safety instructions of the operator must be observed.

- Warning signs and other notices on the machine provide important information for safe operation. Observing them will contribute to your own safety.
- Before starting to work, familiarise yourself with all of the installations and controls and their functions.
- Keep the machine clean to avoid the risk of fire.
- Check the overall visibility of the machine and vehicle from the operator position before pulling away and initial operation. Pay attention to blind spots and if necessary request a banksman.
- Do not start up the machine unless all guarding equipment has been fitted and is in its protective position.
- Stay clear of the turning radius of the machine.

### 2.8 SAFETY INSTRUCTIONS ON THE HYDRAULIC SYSTEM

- Carry out repair, maintenance and cleaning work on the hydraulic system only with switched off engine and non-pressurised hydraulic system.
- Hydraulic systems on the machine are under high pressure. Fluids (hydraulic oil) escaping under high pressure can penetrate the skin and cause serious injuries.
- Make sure that the hydraulic system, of the tractor as well as of the machine, is non-pressurised when connecting the hydraulic hoses to the tractor's hydraulic system.
- Hot hydraulic oil can cause serious burns!
- Take care when working on a hot hydraulic system. Let the hydraulic system cool down and wear protective gloves.
- Inspect hydraulic hoses at regular intervals and replace if damaged or worn. The exchanged lines must comply with the technical requirements provided by the machine manufacturer. Hoses and hose couplings undergo a natural ageing process, even if stored and used correctly; therefore, their period of storage and use is limited. Deviating from these figures, the service life of a hose may be determined according to empirical values, in particular taking into account hazard potential.

## 2.0 SAFETY

---

### 2.9 SAFETY INSTRUCTIONS FOR MOUNTED MACHINES

- There is a risk of injury when attaching or detaching machines to/from the towing vehicle. Pay attention to pinch and shear points.
- Beware of pinch and shear points when operating the parking stand.
- Never allow persons to stand between the towing vehicle and the machine whilst in motion.
- Only attach the machine in accordance with the instructions and only to the prescribed fixtures.
- Follow the operator manual of the towing vehicle.
- Observe permissible dimensions and weights of the vehicle after attaching machines or equipment. The vehicle possibly no longer complies with the general road traffic regulations due to the larger dimensions (length, width, height) and this can cause the expiration of the vehicle's operating permit. It is only permitted to participate in public road traffic taking into consideration the respective legal regulations for machines exceeding the admissible dimensions and weights.
- During transport, secure all moving parts with the safety devices provided to prevent them from moving and to avoid possible accidents!
- Driving, steering, and braking characteristics are influenced by fully mounted or attached machinery and ballast weights. Therefore, pay attention to adequate steering and braking ability.
- Switch off the engine and remove the ignition key before leaving the towing vehicle.
- All powered items (e.g. hydraulic) exhibit pinch and shear points! During operation, it is therefore forbidden to remain within the moving circumference of these parts or to reach into areas where there is a risk of injury due to pinching or shearing.
- Dangerous implements, which may still 'coast' after their drive is switched off, are mounted behind guard assemblies. Therefore, keep well clear until such parts have come to a complete stop. It is forbidden to open or remove guarding equipment such as covers, flaps, etc. on the machine whilst it is in operation! Never reach under guarding equipment.
- Do not carry out any maintenance, repair or cleaning work and do not eliminate any malfunctions on the machine unless the drive and the engine are switched off. Remove the ignition key from the towing vehicle.
- Never stand or work beneath a raised machine. Persons are only allowed to stand or work under suspended machines or machine parts when safety props are fitted (e.g. trestle, crane). This applies in particular for repair and maintenance work.
- Wear suitable protective clothing (protective gloves, safety shoes, etc.) when handling sharp implements, e.g. cutters.
- Do not start up the machine unless all guard assemblies have been fitted and are in their protective position. It is forbidden to open or remove guarding equipment such as covers, flaps, etc. on the machine whilst it is in operation.

## 2.0 SAFETY

### 2.10 IN THE EVENT OF AN ACCIDENT

- Stop the machine immediately.
- If necessary initiate first-aid measures.
- If danger is still present move the person to a safe location.
- Inform the responsible person at the site of operation.
- Alert the necessary emergency services.
- Clear the access roads for emergency vehicles.

### 2.11 IN THE EVENT OF AN ACCIDENT



#### **DANGER!**

**Risk of injury! Serious injuries and death possible!**

Persons can be seriously or fatally injured through the machine's travelling motions and/or through moving parts.

- Switch off the engine prior to any work which requires staying in the danger zone. Remove the ignition key as a precaution and secure the machine against rolling away.
- The operator is responsible for immediately stopping the machine as soon as persons enter the danger zone or use objects to reach into the danger zone.
- Switch off engine and remove ignition key before carrying out any maintenance and repair work.

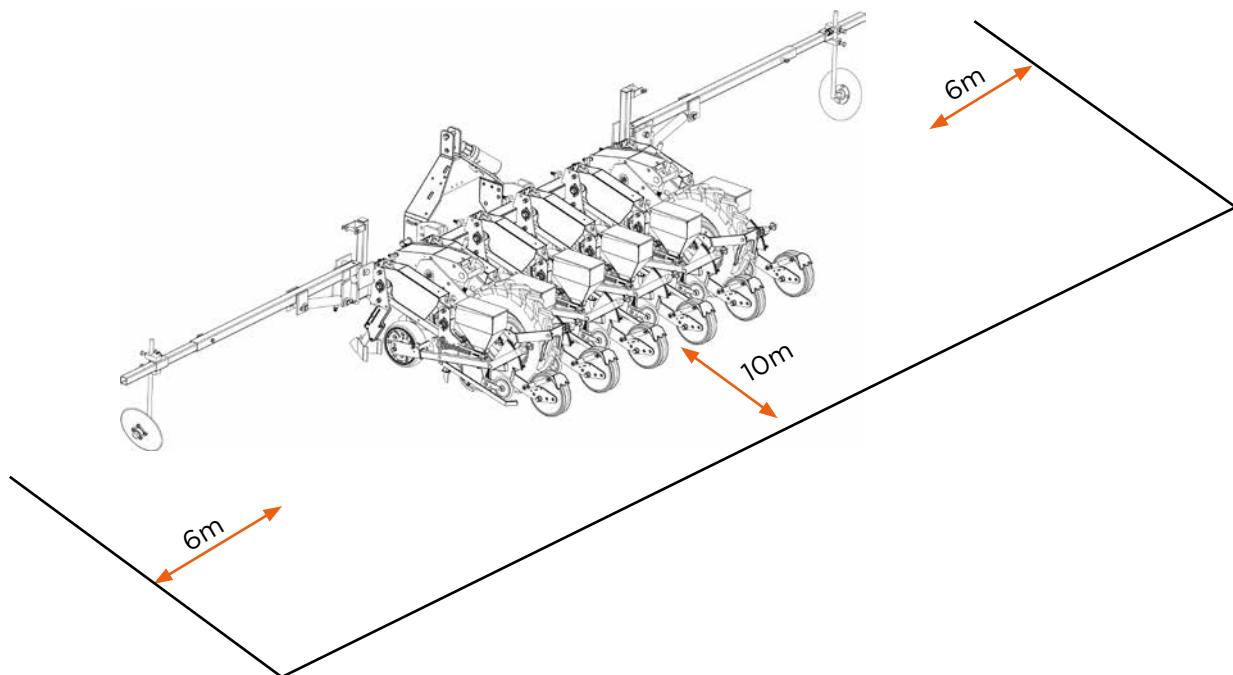

The danger zone is defined by a specified distance to the machine's external dimensions. If the machine dimensions are extended on account of folding elements or additional attachment parts, the danger zone is extended accordingly.

During operation of the machine, nobody may stay in the danger zone. In case of danger, the operator must immediately stop the machine and request the persons concerned to immediately leave the danger zone. The machine may only be restarted once the danger zone is clear of people.

## 2.0 SAFETY

### 2.12 WARNING AND INFORMATION DECALS ON THE MACHINE

The warning labels on the machine indicate areas of danger. Observing these warning labels will contribute to the safety of all persons working on or near the machine. The information on these warning labels must be heeded. All safety instructions must also be passed on to other (new) users. Warning and information labels must be kept in a clean and legible condition at all times.

Replacements for damaged or missing warning and information labels must be immediately ordered from your Stanhay dealer and reattached in the designated places.



It is prohibited to be located in the vicinity of the drive shaft - risk of injury!



Do not stand between the machine and the tractor.



Read the operator manual before operating the machine



Do not stand in the folding range of the folding frame



Do not stand in the folding range of the marker arms



Never reach into the crushing area when parts are moving.



Do not open or remove safety guards while the machine is in operation.

# 2.0 SAFETY

---



Toolbar setting height



Tyre pressure label



Lubrication points



Indicates lifting points on the drill

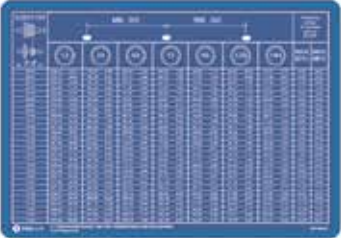

Gear ratio table

## 3.0 MOUNTING THE MACHINE

### 3.1 MOUNTING ONTO THE TRACTOR

Horizontally align the lower guides of the three-point linkage. Ensure that the lower guides are not connected with the tractor via slotted holes in the lifting rods. When in road transport the bottom linkages must be secured at the sides with the help of stabilizers.

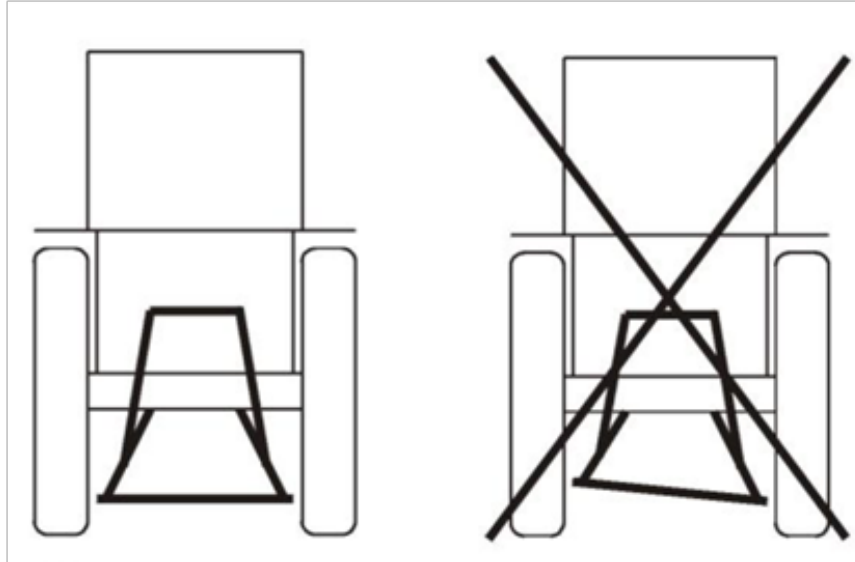

### 3.2 ENSURING THE TRACTORS STABILITY

Attaching implements to the front and rear power take-offs must not lead to the permissible gross vehicle weight and the maximum permissible axle load or the tyre load carrying capacity of the tractor being exceeded. At least 20% of the dead weight of the tractor must be always taken by the front axle of the tractor.



#### **WARNING!**

**Risk of crushing! Serious injuries and death possible!**

People standing between the tractor and the machine while its being attached are at risk of injury.

- Ensure tractor operator is competent. Check tractor operator manual if required.
- Only enter the area between the tractor and the machine when the tractor is switched off, the parking brake is applied and the keys have been taken out of the ignition.



#### **DANGER!**

**Accident Risk! Serious injuries and death possible!**

The weight of the fully mounted machine can have a big effect on the tractors manoeuvrability and stability!

- A stability assessment must be carried out prior to attachment of the machine.
- Adhere to the permissible axle loads, tyre load carrying capacities and minimum ballast weights.



# 3.0 MOUNTING THE MACHINE

## 3.3 PRELIMINARY CHECKS

Before mounting the machine, these checks must have been carried out by either following the calculations below or by having weighed the tractor and implement combination.

INDEX	DESCRIPTION	SOURCE
TL (Kg)	Dead weight of the tractor	Refer to the tractor operator manual
TV (Kg)	Front axle load of the empty tractor	
TH (Kg)	Rear axle load of the empty tractor	
GH (Kg)	Total weight of the rear mounted implement (rear ballast)	Refer to VIN plate
GV (Kg)	Total weight of the front mounted implement (front ballast)	Refer to front mounted implement manual
a (m)	Distance between the centre of gravity of the front mounted implement and centre of front axle	Refer to tractor operator manual and front mounted implement manual
a1 (m)	Distance between the centre of the front axle and the centre of the lower linkage ball	Refer to tractors operator manual or measure
a2 (m)	Distance between the centre of the lower linkage ball and the centre of gravity of the front mounted implement	Refer to the front mounted implement manual
b (m)	Wheel base of tractor	Refer to the tractor operator manual
c (m)	Distance between the centre of the rear axle and the lower linkage ball	
d (m)	Distance between the centre of the lower linkage ball and the centre of gravity of the rear mounted implement	Approximately 35% of the total length of the implement

## 3.0 MOUNTING THE MACHINE

### 3.4 LOAD CALCULATIONS

The calculation for the minimum ballast for the front of the tractor can be calculated from the equation below:

$$\frac{GV_{min} = GH * (c + d) - TV * b + 0.2 * TL * b}{a + b}$$

The calculation for the minimum ballast for the rear of the tractor can be calculated from the equation below:

$$\frac{GH_{min} = GV * a - TH * b + x * TL * b}{b + c + d}$$

The calculation for the actual front axle load can be calculated from the equation below:

$$\frac{TV_{tat} = GV * (a + b) + TV * b - GH * (c + d)}{b}$$

The calculation for the actual gross weight of the vehicle can be calculated from the equation below:

$$G_{tat} = GV + TL + GH$$

The calculation for the actual rear axle load can be calculated from the equation below:

$$TH_{tat} = G_{tat} - TV_{tat}$$

The tyre load carrying capacity should be found on the tyres side wall/tyre manufacturers documents. This figure needs to be doubled (for two tyres).

	Actual calculated value (kg)	Permissible value according to tractors operator manual (kg)	Double permissible tyre load-carrying capacity (two tyres) (kg)
Minimum ballast front/rear	/	N/A	N/A
Gross vehicle weight			N/A
Front axle load			
Rear axle load			



All calculated values must be smaller than or equal to the permissible values. The minimum ballast weight must be attached to the tractor as an implement or ballast weight.

# 3.0 MOUNTING THE MACHINE

## 3.5 CONNECTING THE MACHINE TO THE TRACTOR

These machines are attached to the tractor via the 3 point linkage. The drill headstocks have the option of fitting the drill to a Category 2 and 3 linkage on the tractor.

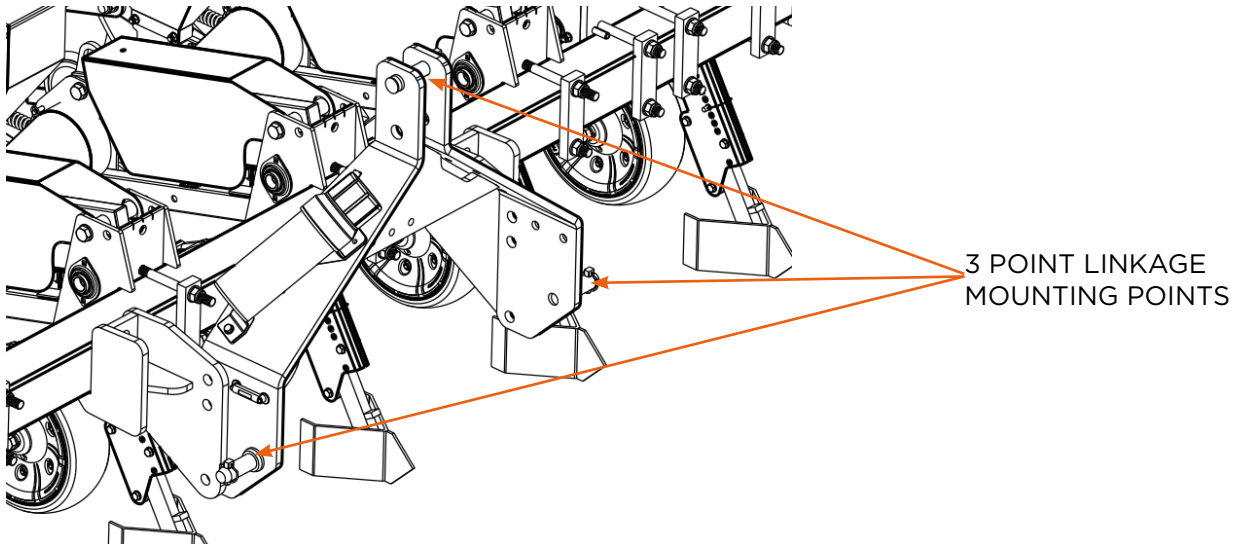

### **WARNING!**

**Risk of crushing! Serious and fatal injuries possible!**

People standing between the tractor and the machine during coupling are subjected to a risk of injury.

- Ensure tractor operator is competent. Check tractor operator manual if required.
- Only enter the area between the tractor and the machine when the tractor is switched off, the parking brake is applied and the keys have been taken out of the ignition.

- Before connecting the machine to the tractor, switch off the tractor, apply the parking brake and remove the ignition key.
- Push the lower link arm balls into the lower link pin, ensure the guide ball inner diameter matches the diameter of the lower link pin.
- Secure the lower guide ball and pin with a linchpin.
- Connect the lower link with the lower link guide shaft of the machine.
- Fold and secure the tractor lower link locks on the tractor.

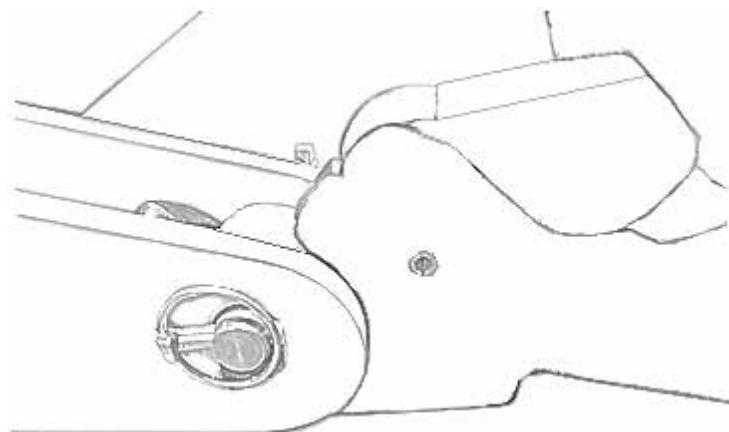

## 3.0 MOUNTING THE MACHINE

→ Connect the top link with the top link pin and support with a linchpin.

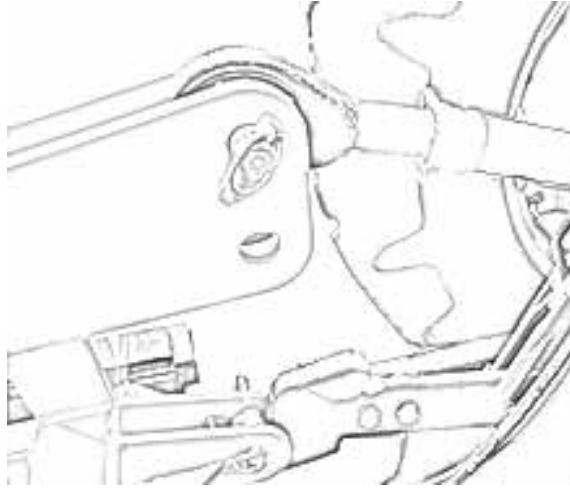

Once the three point linkage is connected proceed to connect any required hydraulic or electrical services to the tractor. When doing so ensure they are routed so as to avoid any pinch or chafing points and will not be damaged during machine operation. Any defective hoses should be replaced immediately.



### **CAUTION!**

**The hydraulic system is under high pressure!**

Fluids under high pressure can penetrate the skin and cause serious injuries. If this occurs seek medical assistance immediately.

- Ensure care is taken when coupling and un-coupling the tractor services.
- Depressurise the hydraulic system on the machine before un-coupling the hydraulic services.



### **WARNING!**

**Unintentionally actuated machine functions may lead to serious or even fatal accidents!**

- Before connecting any hydraulic services, ensure the tractors controls have been switched to a neutral position.



**Ensure the hydraulic hoses are connected to the correct ports on the tractor. Failure to do this may result in the hydraulic services not operating correctly.**

# 3.0 MOUNTING THE MACHINE

---

## 3.6 MOVING PARKING STANDS TO TRANSPORT POSITION

**CAUTION!**

*Risk of crushing! Injuries possible!*

Risk of injury from a manually movable machine part.

- When operating the movable part, ensure the operator is aware of any pinch and shear points.

The parking stands hold the machine in the attached position when it is parked. After attaching the machine to the tractor the parking stand must be raised to their transport position.

See step-by-step guide to doing this procedure below:

- Lift the machine off the ground using the tractors 3 point linkage.
- Turn off the tractor, apply the parking brake and remove the ignition key.
- Remove the lynchpin, remove pin from mounting foot.
- Lift mounting foot upwards until the last hole in the mounting foot locates with the fixed parking stand mounting. Install the pin back into the parking stand through the fixing hole and install the lynchpin.
- Make sure this is applied to all parking stands fitted to the machine.

## 4.0 ROAD TRAVEL

### 4.1 GENERAL SAFETY REGULATIONS FOR ROAD TRAVEL



The provisions of the road traffic regulations of other countries may vary. The requirements of the respective country shall apply where these differ from those of the manufacturer.



Vehicle owners and drivers are responsible for observing the statutory national road traffic provisions.



Never exceed the permissible axle loads and total weights of the tractor. Observe and adhere to the legal and technical limits of the tractor!



Driving, steering, and braking characteristics are influenced by any mounted or attached machinery and ballast weights. Therefore, pay attention to adequate steering and braking ability.



**WARNING!**

**Risk of accident on dirty and slippery roads!**

Soil forms a slippery coating on road surfaces and can jeopardise the safety of other road users.

- Clean the machine before travelling on the road.



**DANGER!**

**Risk of accidents by unsecured machines!**

A machine that is not in a secured transport position may not be used in public road traffic. There can be serious injuries in the event of an accident.

- Only move the machine on public roads when all guarding equipment has been attached and is in the correct (protective) position!



**DANGER!**

**Poor visibility can lead to serious accidents!**

Driving on the road with heavily soiled cabin windows exposes the driver and other persons to danger.

- Make sure the vehicle has good all-round visibility!



**WARNING!**

**Handling tractors requires special safety measures to be taken.**

The notes in the operating instructions of the tractor manufacturer must therefore always be read and followed. Non-compliance may lead to damage to the machine as well as injuries due to accidents.

- Follow the operating instructions of the tractor manufacturer!



**DANGER!**

**Excessive driving speeds can lead to serious accidents!**

Driving at excessive speeds exposes the driver and other persons to danger.

- Always drive at an adequate speed. Observe permissible maximum speed!



**DANGER!**

**Accident risk! Serious injuries and death possible!**

Persons riding on the machine can be seriously injured or fall off the machine and may be run over.

- It is forbidden for persons to ride on the machine!
- It is forbidden to transport any objects on the machine!

# 4.0 ROAD TRAVEL

## 4.2 FOLDING THE MACHINE FOR TRANSPORT

Folding frame machines must be put into the folded position for road transport. On some high density machine configurations it may be necessary to latch units out of work to allow folding as indicated by additional warning stickers on the frame. All additional equipment such as marker arms should also be put into the transport position and all safety mechanical locking devices fitted securely before road transport.



Before commencing a journey, the height of the machine in transport position must be checked. The height may not exceed the national provisions regarding the participation in public road traffic! Adapt the tractor attachment or hydraulic lifting at the tractor where necessary.



### **WARNING!**

**Risk of injury! Serious injuries and death possible!**

Components jutting into oncoming traffic can cause accidents during road travel and jeopardise other road users!

- Completely fold in the main frame before travelling on the road!



### **CAUTION!**

**Risk of crushing! Injuries possible!**

Danger of injury on swivelling machine parts!

- Pay attention to pinch and shear points when unfolding and folding the machine!
- Observe the seeding units' pivoting radius and instruct all persons to leave the danger zone!



### **WARNING!**

**Risk of injury! Serious injuries and death possible!**

Components jutting into oncoming traffic can cause accidents during road travel and jeopardise other road users!

- Bring the lane marker to transport position before travelling on roads!



### **DANGER!**

**Danger of life from electric current!**

Danger of life by contact with high voltage lines.

- Note the machine's transport height.
- Keep an adequate safety distance to high voltage lines. Never carry out the folding operation in the vicinity of high-voltage lines.

## 4.0 ROAD TRAVEL

### 4.3 UNCOUPLING THE HYDRAULIC PRESSURE PIPE

When driving on public roads, no machine functions must be operated. To rule out any accidental actuation, disconnect the pressure pipe from the tractor.

- Depressurise the hydraulic pipes using the corresponding spool valve on the tractor.
- Disconnect the pipes from the tractor.



**WARNING!**

**Risk of injury! Serious injuries and death possible!**

Hydraulic systems accidentally activated during transport can present a risk of accident and jeopardise other road users.

- Disconnect the hydraulic pressure pipe from the tractor prior to road travel!



**WARNING!**

**Risk of injury! Serious injuries and death possible!**

Fluids escaping under high pressure can penetrate the skin and cause serious injuries. If such injuries occur, consult a doctor immediately as otherwise there is a risk of serious infection.

- Depressurise the hydraulic system of the tractor.
- Take care when uncoupling hydraulic lines.



**CAUTION!**

**Risk of burns! Injuries possible!**

Take care when working on a hot hydraulic system. Hot hydraulic oil can cause serious skin burns!

- Let the hydraulic system cool down before you start working on it and wear protective gloves.

### 4.4 CHECKING THE LIGHTING INSTALLATION

Check the lighting installation before every trip for damage, function and cleanliness!



**WARNING!**

**A defective lighting installation jeopardises traffic safety!**

Machines with defective lighting installation can lead to serious accidents because signalling was not possible.

- Check the lighting installation before every trip!
- Immediately replace defective bulbs and lens. Observe specifications!

### 4.5 LIFTING THE MACHINE

Before driving on public roads, the machine must be lifted out of work on the tractor's three point linkage. So as not to exceed the maximum permissible transport height, the machine may only be lifted so far that the distance between the underside of the frame tube and the ground does not exceed 1000mm.



Prior to transporting the machine, fasten the lateral locking device of the tractor's lower guide so that the machine cannot swing back and forth whilst on the road.



# 5.0 PARTS OVERVIEW

## 5.1 ROW UNIT OVERVIEW

- A. Row Unit Lifting Eye.
- B. Unit 'Hang' Adjustment Bolt.
- C. Rear Wheel Pressure Adjustment Spring.
- D. Drive Guard (covering row unit down force adjustment springs).
- E. Unit Depth Adjustment Quadrant.
- F. Metering Unit.
- G. Seed Press Wheel.
- H. Arm Coverer.
- I. Opener Tine.
- J. Parallel Links.
- K. Clod Deflector.
- L. Wheel Scraper.

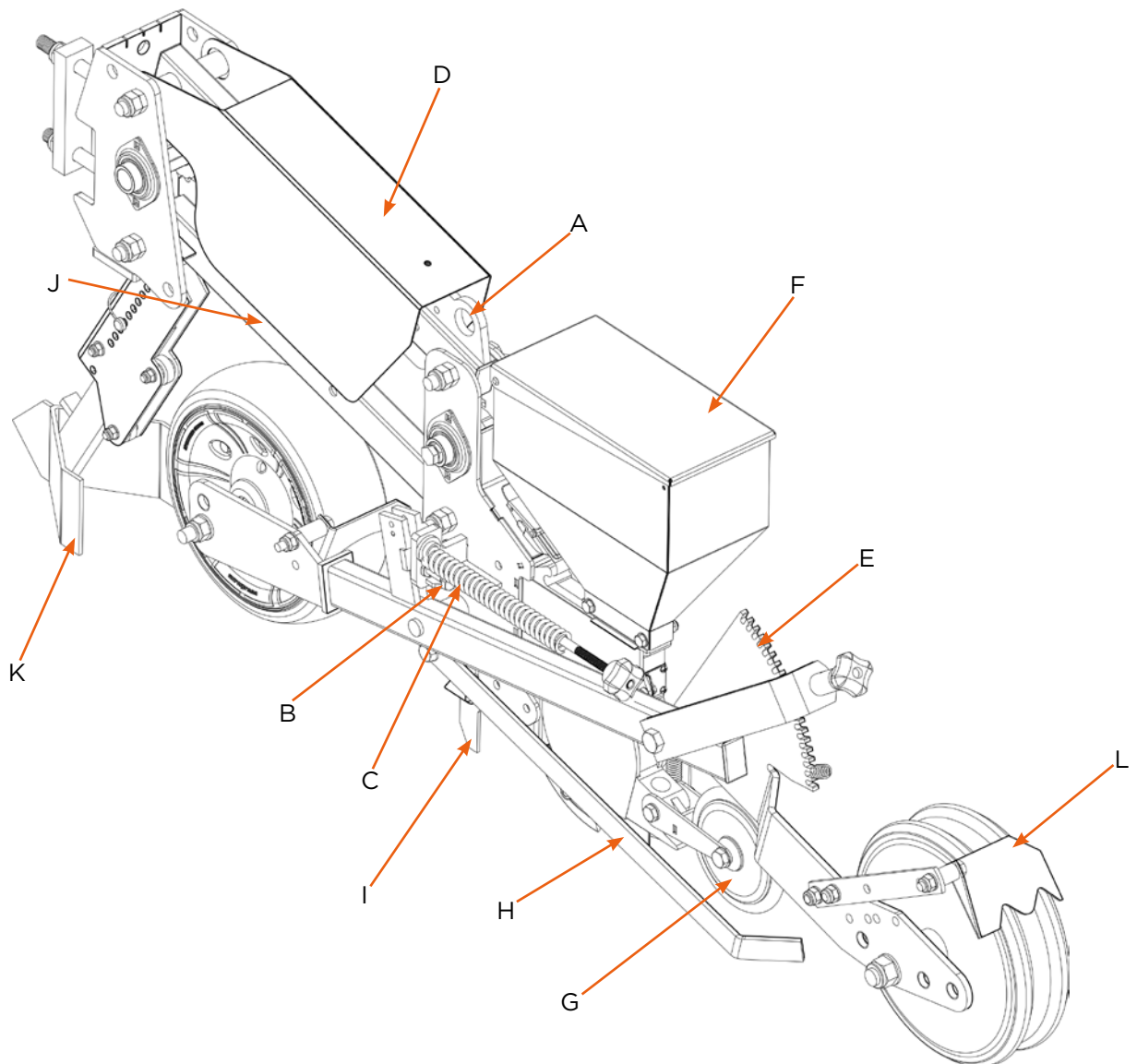

# 5.0 PARTS OVERVIEW

## 5.2 METERING UNIT OVERVIEW

- A. Hopper.
- B. Deflector Wheel.
- C. Deflector Blade.
- D. Brass Sealing Strip (position just clear of selector wheel).
- E. Selector Wheel.
- F. Ejector Blade.
- G. Coulter- Ensure there is no gap here when fitting coulter.

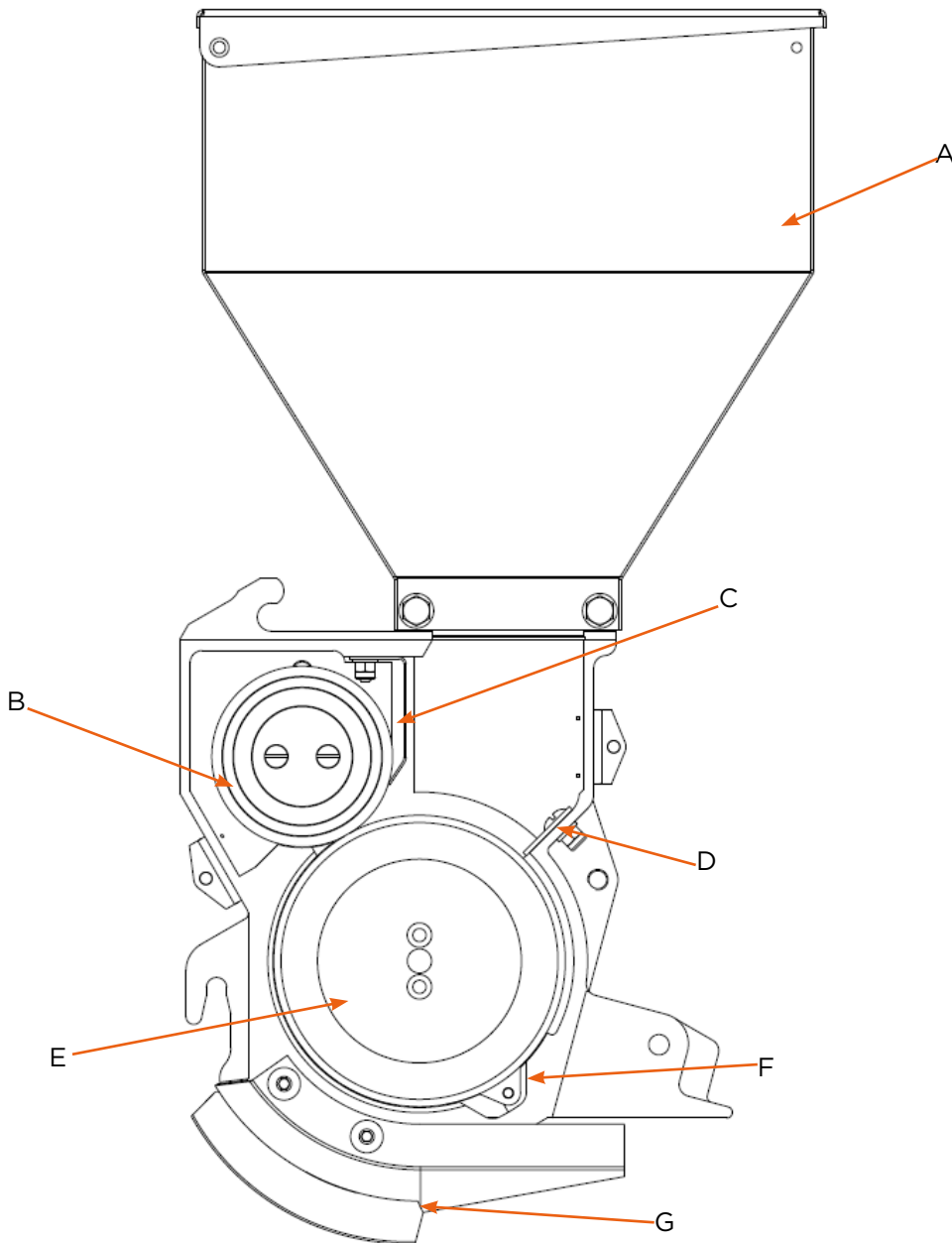

# 5.0 PARTS OVERVIEW

## 5.4 LANDWHEEL OVERVIEW

- A. Wheel 6.00x16 - provides drive.
- B. Jack Screw - adjusts the landwheel height.
- C. Drive Chain - drives the sprockets in the gearbox.
- D. Sprocket Cluster - contains a 22T, 21T, 20T, 19T, 18T, 17T, 16T and 15T sprocket. These are used to help set the gear ratios.
- E. Tensioner Handle - tensions the chain inside the gearbox.
- F. Primary Drive Sprocket - either a 24 or 40T. Used on the initial drive from the landwheel.
- G. Final Drive Sprocket - 2 sliding double sprockets; 24T/17T and a 13T/11T. Provide the final drive to the hex shaft.
- H. Scraper - keeps the tyre of the landwheel clean
- I. Jockey - used for tensioning the external drive chain.
- J. Sprung Loaded Landwheel - on wider drill set ups it maybe necessary to use a sprung loaded landwheel in order to maintain a constant drive on the outside units; this is particularly important on undulating ground where standard 'fixed' landwheels may lose drive and therefore drive to the units. A sprung loaded landwheel conversion kit is available for standard landwheels.

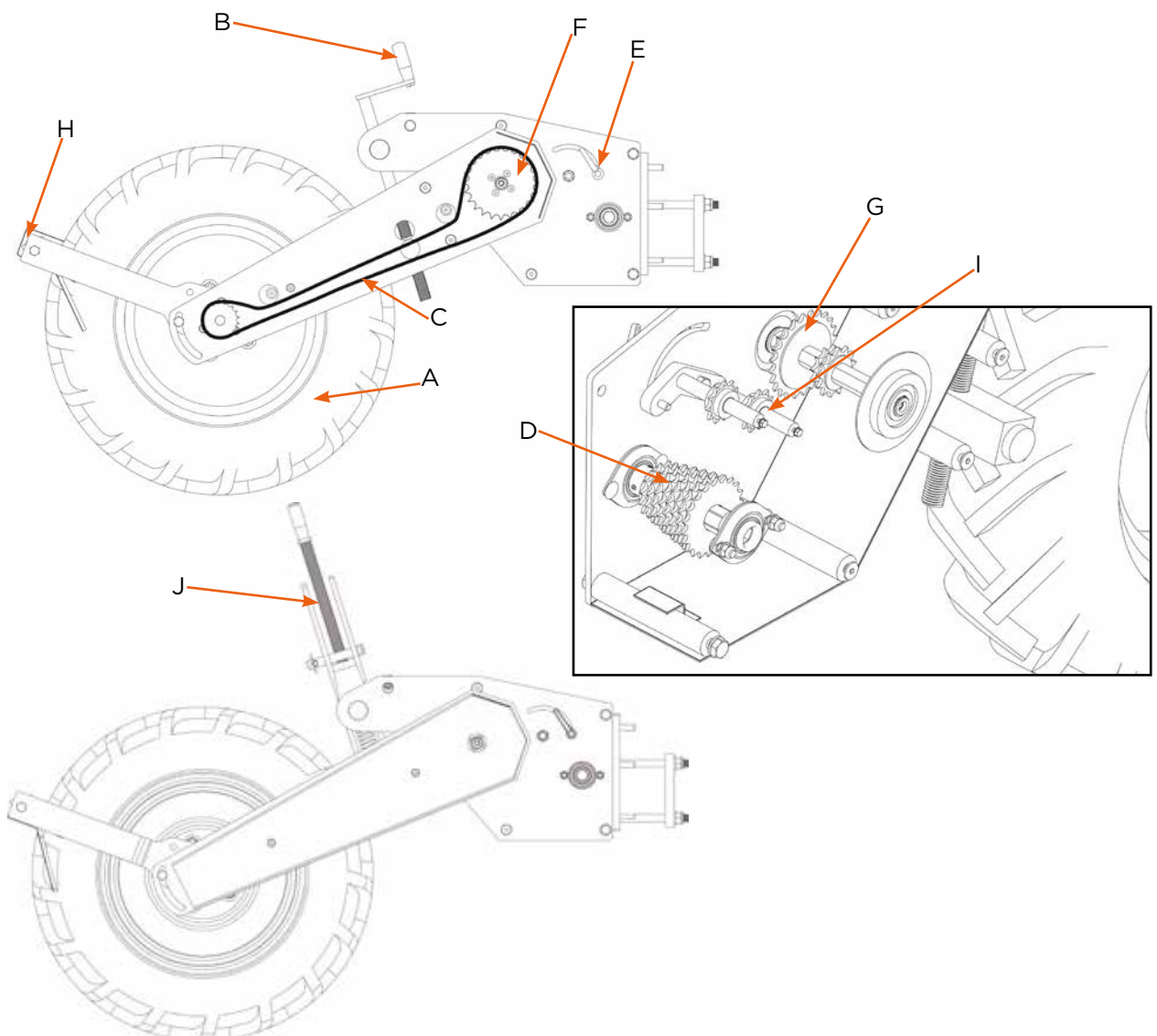

# 6.0 OPERATION AND ADJUSTMENT

## 6.1 METERING UNIT

To remove the metering unit from the row unit first remove guards, slacken the chain tensioner and slide the drive sprocket and chain off the drive shaft by removing the linch pin. Unclip the toggle latch and loosen the lower clamp bolt if necessary. Access to the metering unit is gained by removing the cover plate which is attached by two wing nuts.

## 6.2 SETTING THE UNIT

- Fit the required deflector wheel/spring blade combination and tighten the deflector wheel screws. See recommendations later in manual for the correct setup for the seed type in use. When fitting the fixed spring blade adjust so there is a small clearance between the deflector wheel and fixed spring blade. When setting the spring blade it should lightly press against the deflector wheel tyre.



If the deflector wheel is left in the units between seasons the spring blades will sink into the tyres leaving a permanent groove. The tyres should be replaced and the old tyres allowed to recover before use, or the spring blade will cut into the rubber and render the tyre useless.

- Fit the required selector wheel using the guides in this manual. The ejector blade runs in the selector wheel groove and should be fitted at the same time. Again tighten the fixing screws.



Tight units are generally due to badly fitting ejector/spring blades running too tightly on the deflector wheels.

- Adjust the brass sealing strip so there is a small clearance between it and the selector wheel.
- When the replacing cover plate make sure it is seated firmly against the top edge of the coulter side plates before tightening.

# 6.0 OPERATION AND ADJUSTMENT

## 6.3 DEFLECTOR WHEEL

SEED TYPE		DEFLECTOR WHEEL TYRE & BLADE	
		PART NO	DESCRIPTION
SUGAR BEET PELLETS	NON POLYMER COATED (PLAIN - PINK)	8010060 (1 SET)	BLACK TYRE, WHEEL & FIXED BLADE
	POLYMER COATED (FORCE - GREEN)		
	POLYMER COATED (GAUCHO - BLUE)		
VEGETABLE PELLETS	ALL TYPES (2.75MM DIA. & LARGER)		
DELICATE OR FRAGILE SEEDS	SEEDS WITH A BRITTLE COATING THAT REQUIRE MORE DELICATE AGITATION	S21-00001 S69-00068	FOAM TYRE & FOAM TYRE WHEEL HUB
ALL OTHER SEEDS	PELLETS SMALLER THAN 2.75mm DIA.	8010008 (1 SET)	BROWN TYRE, WHEEL & SPRING BLADE

It is essential that the correct deflector wheel blade is used.

- Fixed deflector wheel blade with black or foam tyre. Adjust to give minimum clearance with out touching the tyre.
- Spring deflector wheel blade with brown tyre. With wheel removed distance from centre of deflector shaft to edge of spring blade should be 41mm.

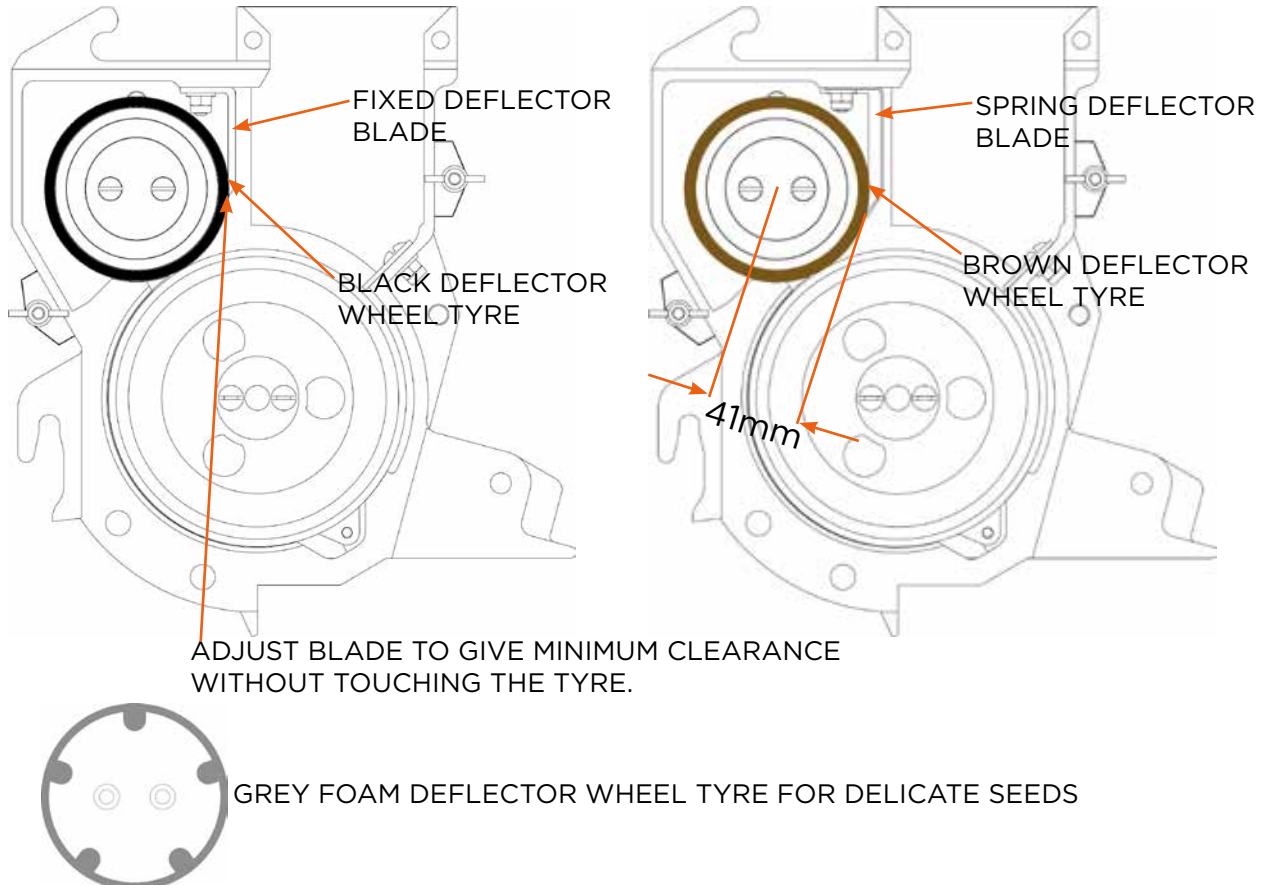

Failure to use the correct deflector wheel blade, properly adjusted, will result in damage to both the seed and deflector wheel tyre.

# 6.0 OPERATION AND ADJUSTMENT

## 6.4 EJECTOR BLADE

As standard the S1 ejector blade is used and fitted with nearly all seed types. Other ejector blade styles are available on request.

## 6.5 SELECTOR WHEEL

Each selector wheel has an identification code marked on the side, visible when the metering unit cover plate is removed (or through it when the transparent cover is used). The prefix letter denotes the wheel type and will determine the cup size and depth. This is then followed by a number showing the amount of cups in the wheel. To determine the selector wheel required refer to the selector wheel guide below and the seed spacing chart (see section 11) for the number of cups in the wheel to give the required seed spacing range.

To correctly set up the metering unit for a seed type use the guide below to select the selector wheel, deflector wheel and ejector blade.

SEED	SEED CODE LETTER	SEED SIZE (mm)	SELECTOR WHEEL TYPE
SUGAR BEET- PELLETED	Q-U	3.50- 4.75	EP
FODDER BEET- PELLETED	P-U	3.25- 4.75	EP
BEETROOT/ RED BEET	M-R	2.75- 4.00	E187
	Q-S	3.50- 4.25	E
BRASSICAE	H	1.75- 2.00	B
	J	2.00- 2.25	C
	K	2.25- 2.50	D
CARROT	UNGRADED NATURAL	-	K
CARROT- PELLETED	-	2.75- 3.25	PO X 150
LEEK	H	1.75- 2.00	B
	J	2.00- 2.25	C
LETTUCE	UNGRADED NATURAL	-	J
LETTUCE- PELLETED		3.00- 3.50	PL X 170
ONION- NATURAL	K	2.25- 2.50	G
ONION- PELLETED	-	2.75- 3.25	PO X 150
	-	3.00- 3.50	PO X 160
PARSNIP	S-U	4.00- 4.75	P SHALLOW CP
	V-X	4.75- 5.50	P STANDARD CUP
RADISH	UNGRADED NATURAL	-	E187
SWEDE	H	1.75- 2.00	B
TURNIP	G	1.50- 1.75	A

# 6.0 OPERATION AND ADJUSTMENT

## 6.6 COULTER FITMENT AND SELECTION

The coulters are clamped to the bottom of the unit body casting between stainless steel clamping plates by two pairs of socket head screws. When fitting the standard single line coulters ensure that the vertical rear face of the coulters tip locates firmly against the cut-outs in the casting to prevent soil entering the seed outlet area. Holding the coulters in position, tighten the fasteners until the coulters are firmly clamped in place.

The Seven is supplied with cast coulters as standard which are suitable for sticky and/or abrasive soils. A ceramic coulters is also available.

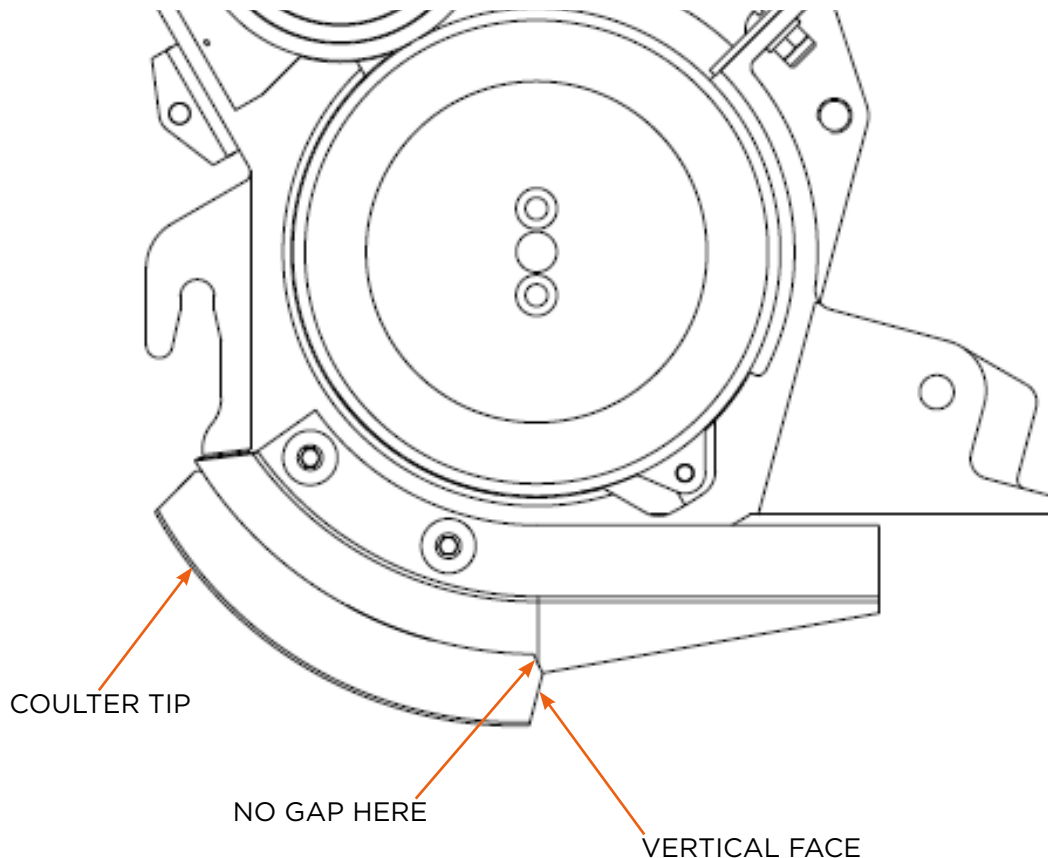

## 6.7 COULTER RECOMMENDATIONS

DESCRIPTION	RECOMMENDED FOR
Single Line Cast	General Purpose
Single Line Ceramic	Sticky and/or abrasive

## 6.0 OPERATION AND ADJUSTMENT

### 6.8 COULTER DEPTH SETTING

Set rear wheel depth adjustment quadrant to give a sowing depth slightly shallower than the required normal drilling depth.



Field adjustment of sowing depth is most easily achieved by progressively adjusting coulters downwards until the desired sowing depth is achieved.

Coulter depth can be adjusted in 2.5mm increments. 5mm increments are obtained by pulling the spring-loaded depth adjustment pin (A) and rotating the quadrant through one slot. 2.5mm increments are achieved through rotating the bolt through 180°.

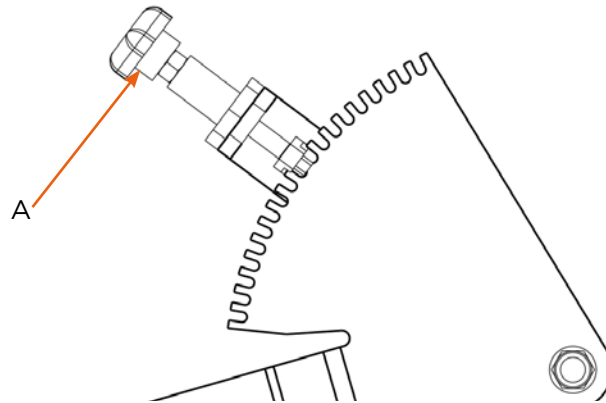

### 6.9 SEED PRESS WHEEL (OPTIONAL)

The seed press wheel attached to the rear of the metering unit is sprung loaded into work. LATCH SEED PRESS WHEEL OUT OF WORK IF SOIL IS DAMP. This is done by lifting the wheel as high as possible and locating the swinging latch on top of the lower spring pin. There are two types of press wheel available, standard (150mm) and large (190mm).

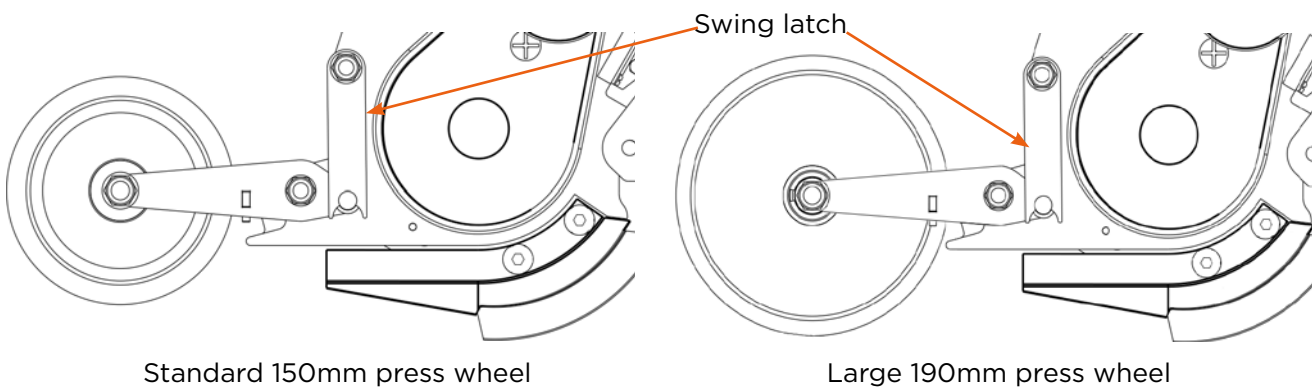

Standard 150mm press wheel

Large 190mm press wheel

### 6.10 ARM OR DRAG COVERERS

The sprung loaded arm coverers can be adjusted to give varied soil covering capabilities. The standard unit comes with one coverer, but two can be specified at time of order for heavy soils.

Moving the spring to the holes nearest the tractor increases the down force of the coverer. This may be applicable when moving from fields with varying soil conditions.



To much spring tension on light soil may bulldoze the soil and dig up the seed.



Wide and narrow 2 chain drag coverers are also available.



## 6.0 OPERATION AND ADJUSTMENT

### 6.12 CLOD DEFLECTOR

The telescopic clod deflector is an optional fitment on the Seven. The clod deflector can be pinned out of work for fine seed bed conditions or used in the flat mode for cloddy/stony soil conditions. Adjusting the position of the stop varies the amount of soil moved by the deflector. Lowering the stop pin increases the amount of soil moved.

### 6.13 CHANGING THE GEAR RATIOS IN THE GEARBOX

To set the correct ratios for seed spacing follow the instructions below:

- Loosen the clamp handle (A) on the side of the landwheel to release the idler sprockets.
- Undo the grub screw in the required sliding sprocket (B) - it may be necessary to rotate the landwheel so that the grub screw is accessible.
- Fit the chain over the required sprocket in the cluster (C).
- Then fit chain over the sliding sprocket then re-tighten the idle sprockets (D) the with clamp handle.
- Rotate landwheel and check the chain is running in line.

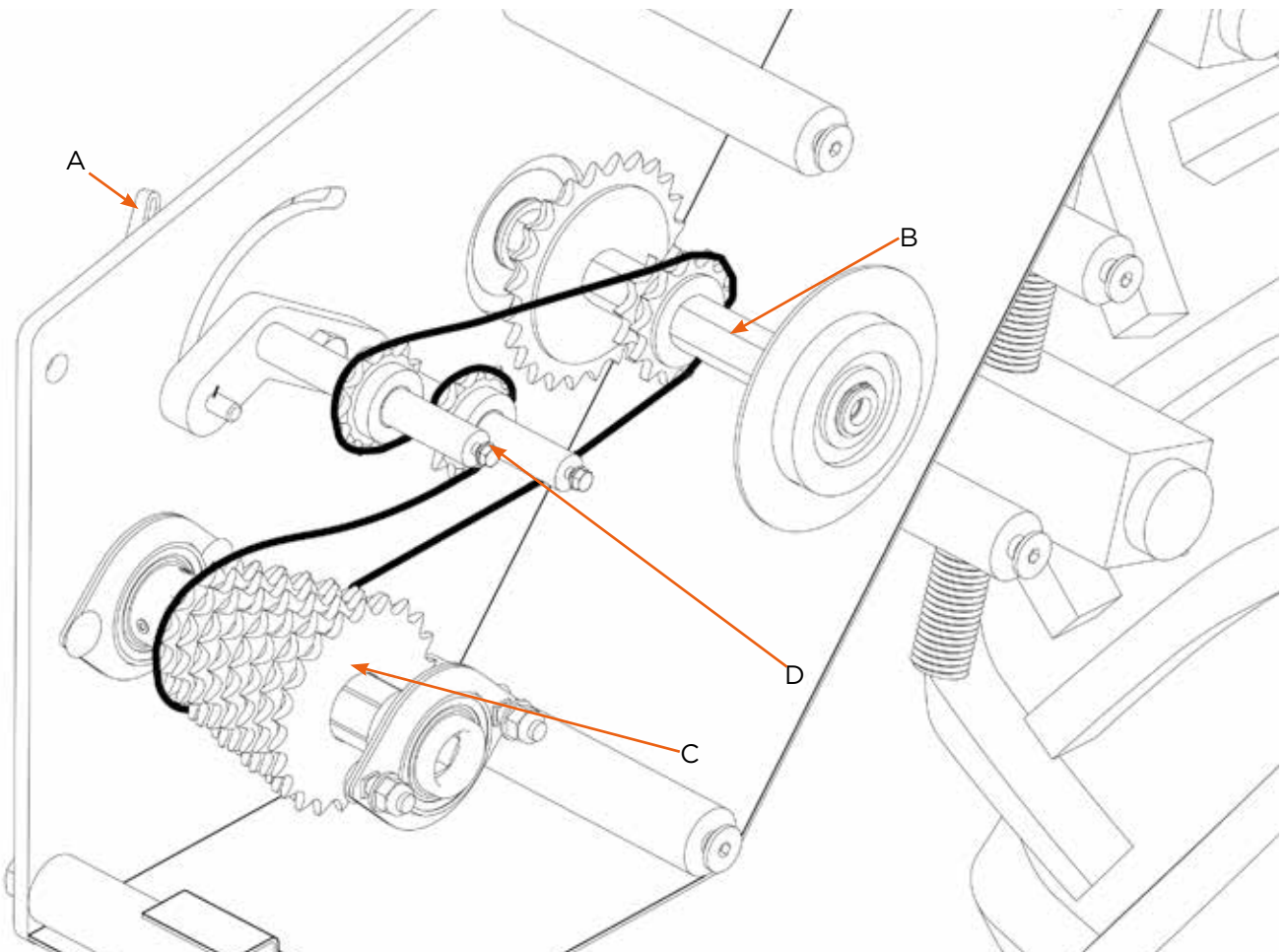

Ensure the drive chains are correctly tensioned and the clamp handle is locked before use. Improper use can lead to serious damage to the gearbox.



Gearboxes connected to the same hex shaft must be set the same or major mechanical damage could result.

# 6.0 OPERATION AND ADJUSTMENT

## 6.14 DOWNFORCE SETTING

The row unit is equipped with downforce settings via the spring assembly on the parallel links. Adjustment of a settings is easy and can be done by attaching the spring to one of the three spring anchors on the upper link.

The possible positions of the downforce spring on the upper link are marked below. The highest level of downforce is with the spring in position 1 and the least in position 3.

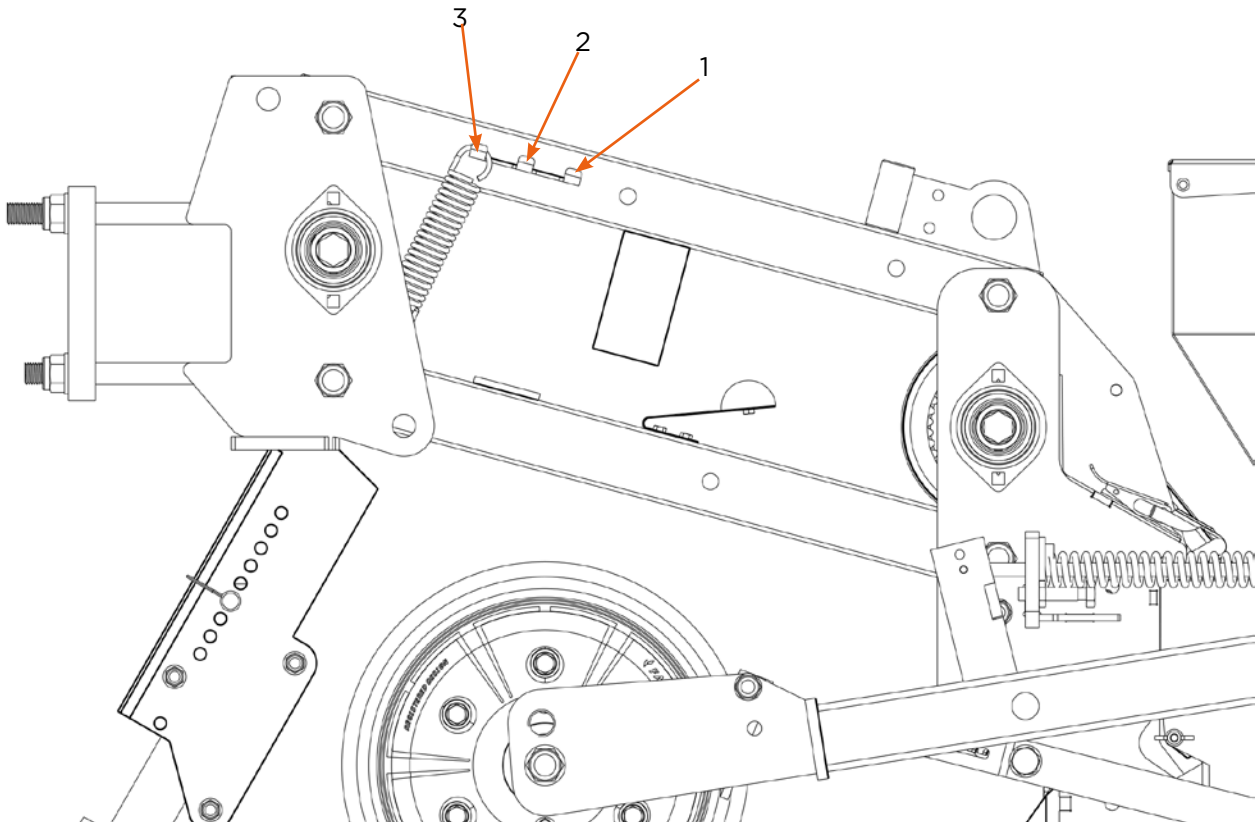

## 6.0 OPERATION AND ADJUSTMENT

### 6.15 SINGLE FOLD HYDRAULIC MARKERS

The single fold markers are operated by single acting hydraulic rams. They can be operated together or individually as required.

During operation the transport locking pins must firstly be removed and markers allowed to pass the pinning point. The pins should then be refitted to prevent the marker operating over-centre.

Care must be taken to ensure that in transport the marker extremities do not exceed 3.00m. In such a case, the beam and disc can be unpinned and rotated through 180, so they face inwards when folded up. Unpinned the beam will slide into the marker ensuring it does not exceed the 4.00m max road height regulations.

Adjustments for marking widths and depths can be made by slackening two M16 bolts at the disc stem end.



The transport lock pins must be refitted (securing the marker arm) for road transport at all times.

### 6.16 TWIN FOLD HYDRAULIC MARKERS

Twin fold markers are fitted to stacking toolbars, vertical folders and wide rigid toolbars. They are powered by double acting rams, from separate hydraulic services.

Adjustment to marking widths are made by slackening two M16 bolts on the 2nd stage of the arm, allowing the marker beam to be slid in or out.

### 6.17 RIGID TOOLBARS

Rigid toolbars are used for both small and large machines where hydraulic folding for transport is not required. In instances where road transport is required the use of a low-loader trailer may be needed.

### 6.18 FOLDING TOOLBAR

The 6m stacking toolbar allows drill widths greater than 3m to be transported by road whilst keeping the seed metering units upright. Stackers, split into three sections, the centre being a fixed toolbar and two outer wings rising parallel above the centre section using double acting rams. A single hydraulic service operates both rams. Be aware that one side may well raise before the other dependant on the loading on each wing.

When in the transport position with the drill folded ensure the mechanical lock is fitted. This must then be removed before attempting to unfold the drill.



Avoid low obstructions when transporting in the stacked mode to prevent mechanical damage.



When storing the drill in its stacked mode ensure it is on firm and level ground.

# 7.0 SETTING UP FOR WORK

## 7.1 IN THE YARD

- Mount drill on tractor 3-point linkage.
- Lower drill to ground, draw forward and check row widths at coulter tips.
- Number the metering units using a marker pen and remove each unit.
- Remove the wing nuts and cover plate and check the correct selector wheel is fitted, together with ejector blade (See seed setting guides and deflector wheel tyre recommendations).
- Check the condition of the deflector wheel tyres, and replace if badly grooved or damaged, together with new spring blade if required.



If the deflector wheel is left in the units between seasons the spring blades will sink into the tyres leaving a permanent groove. The tyres should be replaced and the old tyres allowed to recover before use or the spring blade will cut into the runner and render the tyre useless.

- Tighten the selector and deflector wheel screws and replace the cover plate.



Tight units are generally due to badly fitting ejector/spring blades running too tightly on the deflector wheels.

- Check coulter tips are correctly fitted. Check for excessive wear. It is essential that the rear of the coulter tip locates firmly against the cut outs in the stainless steel clamping plates.
- If fitted, ensure the seed press wheels and tyres are in good condition, pivot and rotate freely: latch up out of work.
- Refit the metering units and connect the drive chain ensuring it is tensioned correctly, and the units turn freely by rotating the land wheel with the machine raised off the ground.
- Check the row units with the machine raised off the ground.
  - Wheels: check all wheels rotate and check adjustment of scrapers and cleaners.
  - Pivots: check nuts and bolts are tight whilst allowing the chassis to pivot freely.
  - Clod deflectors: check blade slides freely in the track, then pin out of work.
- Check hydraulic operations for cracked/leaking hoses, couplings and rams on markers and stacking/folding system.
- Check tyre pressures. The correct landwheel tyre pressure is 6.00-16 3.3 bar – 48 p.s.i.

# 7.0 SETTING UP FOR WORK

## 7.2 IN THE FIELD

- Adjust the tractor linkage so the headstock pins are horizontal. Linkage stabilizers or check chains should be tight.
- The toolbar height should be set from the top of the surface being drilled into to the centre of the toolbar. See section 8.3 for instructions on setting the toolbar height.
- Ensure headstock and toolbar clamping faces are vertical – adjust top link as necessary.
- Lift drill out of work and check for blocked coulters.
- Lower the clod deflectors if needed.
- Latch seed press wheels out of work if soil is damp (should only be used in dry conditions where soil does not pack).
- Set the bout markers for centre line or wheel marking.
- Fill hoppers with clean uncontaminated seed and close lids firmly.
- Lower drill into work under forward movement. Drill a few metres. Check seed for sowing depth and in-line spacing. Adjust depth if necessary.
- Re-check sowing depth, at the same time checking the performance of the clod deflectors and seed coverers. Adjust as necessary.
- Check that scrapers are cleaning wheels satisfactorily and adjust if necessary.
- On the second or third bouts, check the row matching, and adjust bout markers if necessary.



Correct operation is the responsibility of the operator who should check periodically that the desired seeding rate, planting depth and machine performance are being achieved.

## 7.3 SET TOOLBAR HEIGHT

Set the toolbar height by adjusting the landwheels turning handle (A) Set the height to 510mm (550mm for 180mm Toolbar), measured between the surface of the seedbed and the centre of the toolbar. The drill headstock and toolbar should be perpendicular to the ground, this can be altered by adjusting the length of the tractors top link. When set correctly this ensures the maximum allowable travel can be achieved by the row unit to correctly follow the ground contours.

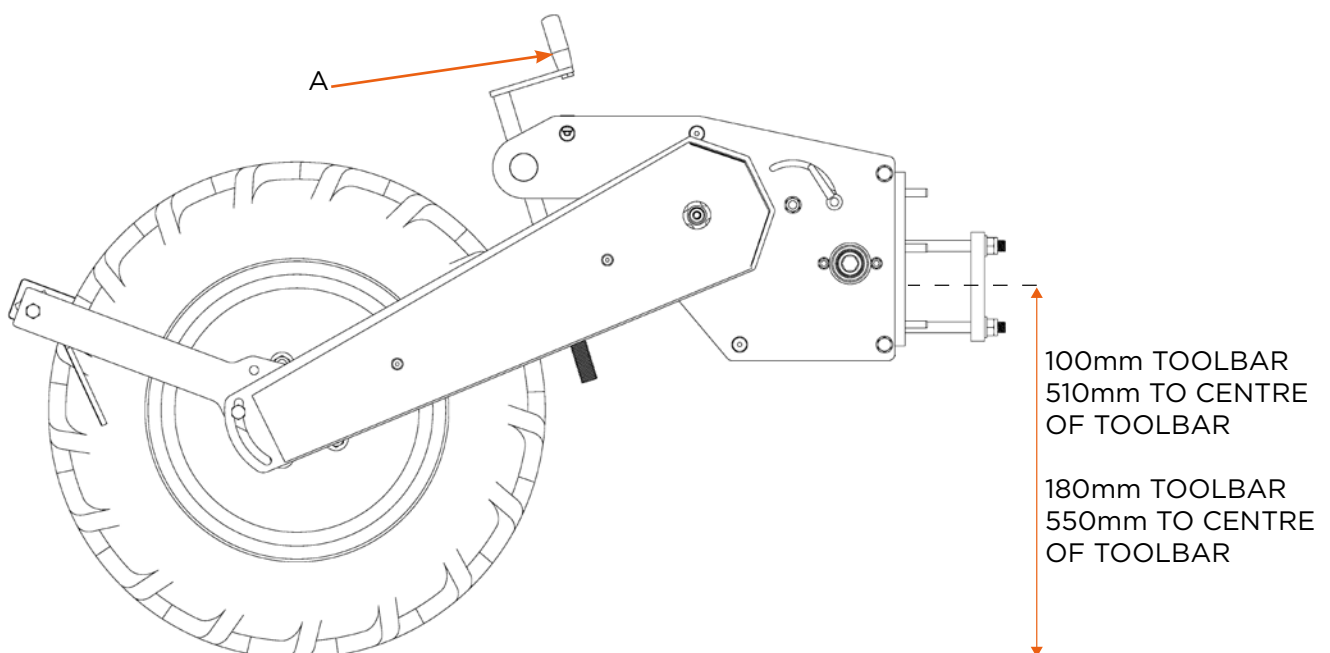

# 7.0 SETTING UP FOR WORK

## 7.4 RULES OF OPERATION

- Always keep the hopper lids closed.
- The drill should always be lowered into work on the move to prevent coulter blockage.
- If stopped in the middle of the field the unit should be raised and the coulters checked for a blockage, then lowered whilst on the move. The drill should not be allowed to move backwards in work.
- Always raise the drill when turning at headlands.
- When the drill is lowered into work the tractor linkage control lever should be set to the 'fully down' position to prevent the drill being carried on the linkage.
- Do not drill in very sticky conditions. For efficient performance soil engaging components must remain clean.

## 7.5 FIELD CHECKS

- Are all the units operating correctly? With the drill raised out of work and check that seeds are dropping from the units.
- Is the seed being drilled into moisture at the bottom of the furrow? If the seed is not at the furrow bottom SLOW DOWN.
- Are the seed press wheels being used unnecessarily? Germinated seeds will die if starved of oxygen by being packed in wet soil.
- Is the seed being covered by fine moist soil? If not, adjust clod defectors and/or covers.
- Is the seed depth adequate? If in doubt, go deeper - SLOW EMERGENCE IS BETTER THAN NO EMERGENCE because of drying out.
- Is the toolbar height correct- 51cm (100mm toolbar)/ 55cm (180mm toolbar).
- Always fill hoppers equally. Uneven emptying is a good indication of a faulty unit.



Maximum forward speeds recorded in the seed spacing charts refer to the performance of the seed metering mechanism. Actual drilling speeds are dictated by field conditions and must be decided by the operator. Excessive forward speed will result in uneven seed depth and poor spacing.



25rpm is the average maximum recommended rotation speed of the cell wheel but dependant on number and style of cell wheel this maximum speed may differ. Always check performance in the field to confirm the unit is performing as required.

# 8.0 FIELD OPERATION

## 8.1 TRACTOR LINKAGE CONTROL & COULTERS

- Lower and raise machine on the move to prevent coultter blockages.
- Raise machine and check coultters for blockages if you have stopped for any reason whilst drilling.
- Move tractor linkage control lever to "fully down or float" position when going into work to ensure adequate land wheel drive.

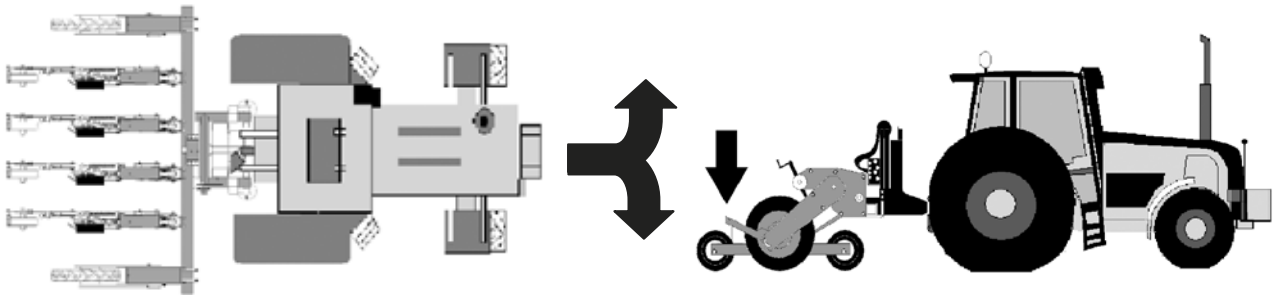

Do not attempt to turn to the left or right with the implement in the ground. Always raise the implement before turning.

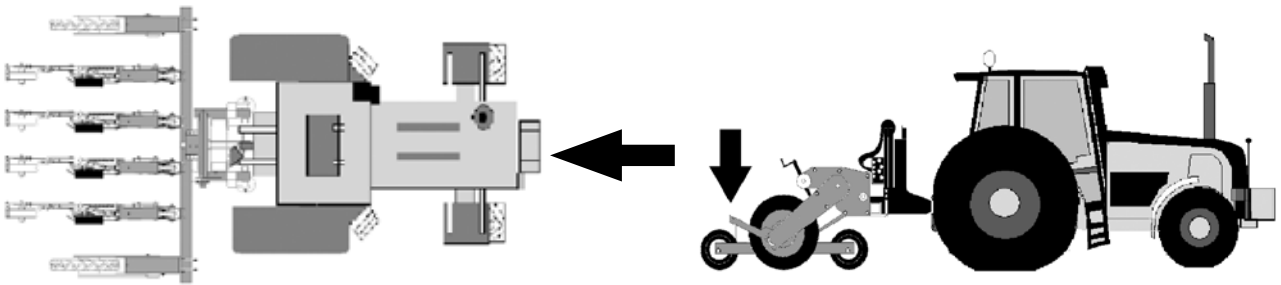

Do not attempt to reverse with the implement in the ground. Always raise the implement before reversing.

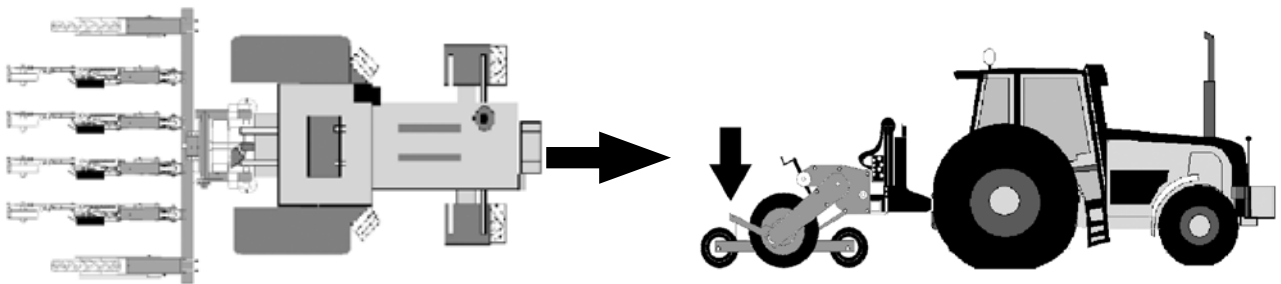

Do not drive at excessive speeds when drilling.



## 9.0 DISMOUNTING THE MACHINE

The following steps must be carried out in sequence to dismantle the machine:

- Empty the seed hopper.
- Discharge the ballasting of the machine if fitted.
- Deploy the parking stands and lower the machine down so it sits on the parking stands.

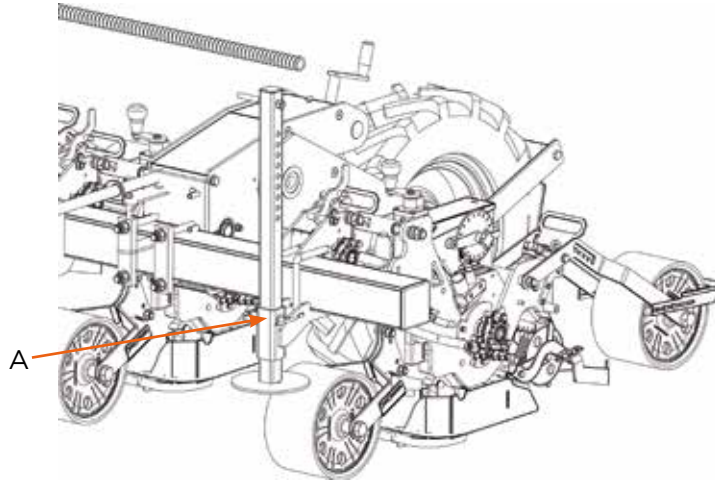

The procedure for lowering the parking stands is detailed below:

- Lift the machine up off the ground via the 3 point linkage on the tractor.
- Switch off tractor, apply the parking brake and remove ignition key.
- Remove spring clip and remove pin (A).

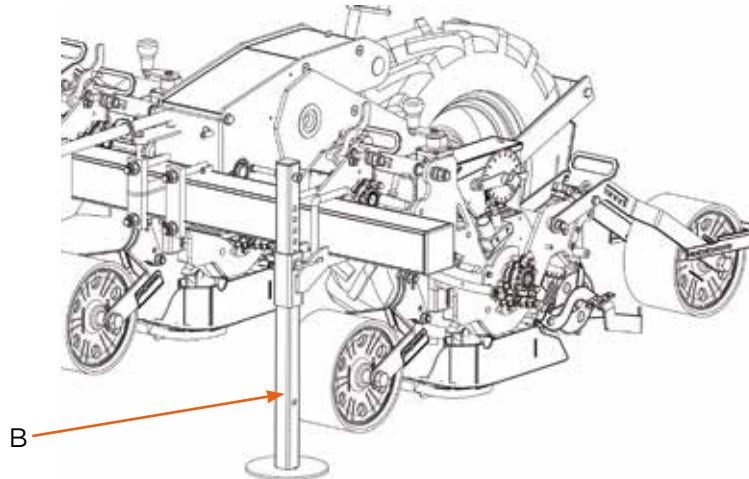

- Slide parking stand foot (B) down so that it locates with one of the mounting holes in the parking stand.
- Fix the pin and spring clip back into the parking stand.
- Drop the machine down using the tractors 3 point linkage. Ensure when the machine is in its parked position that the metering unit coulters are not touching the ground. If this occurs, lift the machine back up on the 3 point linkage and drop the parking stand down into another hole to fix the drill in a higher position.
- Switch off tractor, apply parking brake and remove ignition keys.
- Disconnect the hydraulic hoses from the tractor. Fix the hoses onto their fixing point on the machine to ensure they stay clean.
- Finally disconnect the machine from the tractors 3 point linkage.



## 9.0 DISMOUNTING THE MACHINE

**DANGER!**

The hydraulic system is under high pressure!

Hydraulic fluid escaping under high pressure can penetrate the skin and cause serious injuries. If this occurs, seek immediate medical assistance.

- Take appropriate action when uncoupling hydraulic hoses.
- Depressurise the hydraulic system before disconnecting the hydraulic hoses.

**WARNING!**

Risk of burns!

If the hydraulic system has been operated for a long period of time, there is a risk of it being a high temperature. This could cause serious skin burns.

- Take appropriate action when uncoupling hydraulic hoses.
- Let the hydraulic system cool down before working on it. Ensure correct protective equipment is worn.

**CAUTION!**

Risk of crushing! Injuries possible!

Risk of injury on manually movable machine parts.

- When operating manually movable machine components, ensure care is taken around pinch and shear points.

**WARNING!**

Risk of crushing!

Serious injuries and death possible! People standing between the tractor and the machine while its being attached are at risk of injury.

- Ensure tractor operator is competent. Check tractor operator manual if required.
- Only enter the area between the tractor and the machine when the tractor is switched off, the parking brake is applied and the keys have been taken out of the ignition.

**WARNING!**

Danger of falling or tipping if the ground is unstable!

Machines on uneven or soft ground could tip/fall over.

- Ensure the ground on which the machine is parked must be dry, firm and level.

# 10.0 GENERAL MAINTENANCE

## 10.1 PRE-STORAGE

- Remove the seed metering units.
- Remove and clean selector and deflector wheels. Do not replace ejector blades in the selector wheel grooves as some seed dressing will cause the blades and wheels to corrode together.
- Clean the units; making sure all traces of seed dressing is removed to prevent corrosion.
- Remove cover plate from back of unit and grease chain lightly.
- Check coulter for excessive wear and replace tip if necessary.
- Store units in dry place.
- Clean the outfit thoroughly, lubricate and grease bright parts.

## 10.2 MAINTENANCE STAGES FOR THE MACHINE

In order to maintain operational reliability, the machine must be checked, serviced and maintained at regular intervals. This must be done at different maintenance levels for which different groups of persons are responsible. A difference is here made between maintenance work carried out by the machine operator, the Stanhay dealer and the Stanhay service technician.

If the prescribed maintenance jobs are not carried out by the respectively responsible person, the warranty shall lapse.

The machine operator must ensure that all stipulated measures are carried out in due time and are also recorded. This includes daily cleaning just like presenting the machine for an inspection at the Stanhay dealer.

Certain maintenance jobs may only be carried out by specialist staff (Stanhay service technician or Stanhay dealer). The maintenance levels determine unambiguously who has to carry out the stipulated measures.

The division into maintenance stages stipulates that:

- The machine operator carries out the binding measures described in the maintenance table (e.g. cleaning, lubricating, checking).
- The machine operator initiates the execution of the measures. Apart from that, he must monitor the maintenance intervals and is responsible for presenting the machine at the Stanhay dealer in due time.
- The Stanhay dealer carries out the measures the machine operator may not carry out or cannot carry out due to not having access to specialist equipment (e.g. lacking crane).
- The Stanhay dealer, in consultation with Stanhay Service, carries out certain measures and decides on the basis of the maintenance tables whether an order for a Stanhay service engineer has to be placed.

# 10.0 GENERAL MAINTENANCE

## 10.2 MAINTENANCE TABLE FOR THE MACHINE OPERATOR

CHECK	CHECK	ACTION
Daily	Cell Wheels	Check that the holes in the cell wheels are clear of debris.
	Clean Metering Units	Ensure that the inside of the metering units are cleaned and free of any seed residue at the end of each day.
Weekly	Grease points/ Oil chains	Grease all points on the drill and lubricate drive chains.
	Check Hydraulics	Check hydraulic systems are in good working order and not leaking (if fitted).
	Nuts and Bolts	Check fittings and fixtures are sufficiently tightened whilst still allowing pivot points to move freely.
	Coulters	Check that ribs or bases on the coulters are not excessively worn or damaged as this will severely impede the consistency of the drilling depth.
	Tyre Pressures	Chain drive landwheels: 6.00 - 16 3.3 bar (48psi)
	Check Drives	Check sprockets and chain drives run freely and teeth or links aren't worn or damaged.

# 10.0 GENERAL MAINTENANCE

---

## 10.3 INSPECTION/ MAINTENANCE

The following maintenance instructions are designed to help you to ensure that the machine is always ready for use, provides the necessary operating and traffic safety, thus preserving the high value of the Stanhay products through careful maintenance, servicing and technical monitoring.

- Regular cleaning is a part of maintenance. Dirt attracts humidity and causes rust. All coarse external dirt must be removed. Rectify paint damages at the earliest opportunity. Always keep sensitive and important elements such as magnets, valves, warning boards and displays clean.
- Regularly check all hydraulic components for leakages. Repair leakages immediately. Loss of oil can lead to malfunctioning or loss of operating and traffic safety. In addition leaking oil contaminates the environment.
- Check moving parts (pivot points etc.) regularly for ease of movement, dismantle if necessary, clean and check for signs of wear. Replace with new parts if necessary. Defective or non-functioning parts can hamper the operational reliability of the machine. Also check the fastening elements (such as screws and nuts) regularly and tighten them, if necessary.
- Do not operate machines or appliances with defective parts or parts that are not functioning properly, irrespective of whether these are electrical, hydraulic or mechanical parts. This can result in serious failures or accidents. The manufacturer does not accept any liability in such cases.
- Stanhay recommends that you carry out functional tests at regular intervals and maintain a log of the same. You can thus detect unplanned wear and tear at an early stage and quickly rectify the cause.
- Early detection can help you identify malfunctioning of the machine, prevent damage and thus any other hazards that may arise from such damage. Therefore, always pay attention to any unusual noises or loose fastening elements.
- Consistent checking and proper maintenance can also help you in reducing repair costs and down times. Reliability and service life are increased at the same time.
- Machine check with the Stanhay dealer: The trained expert staff at your local Stanhay dealer will competently carry out maintenance and repair work on Stanhay precision seed drills. We recommend all the users of our products to work out an action plan for machine maintenance together with their dealer.



Damages of any type, production losses or accidents caused by poor maintenance and care cannot be attributed to the manufacturer and are thus excluded from any liability of the manufacturer!

# 10.0 GENERAL MAINTENANCE

## 10.4 SPARE PARTS

Please quote the type designation and the identification number of the machine when ordering accessories and spare parts.

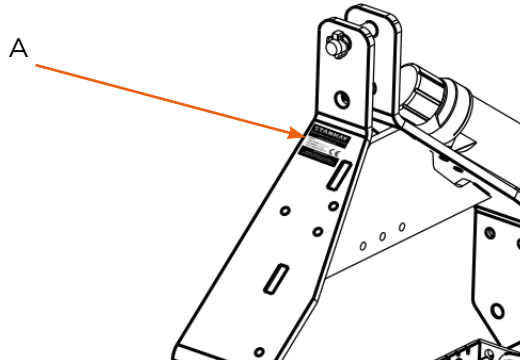

The identification and type plate is positioned on the side of the headstock (A).



The use of spare parts supplied by other manufacturers is prohibited. Original spare parts and accessories approved by the manufacturer are a contribution to safety and guarantee proper functionality. No liability can be taken for consequences resulting from the use of other parts.



The identification plate is a critical part of the drill and must not be removed, changed or made illegible!



When replacing electrical or hydraulic parts, only use original Stanhay spare parts. The use of parts purchased elsewhere can cause malfunctioning of the machine.

## 10.5 WELDING WORK

Incorrect welding work compromises the machine's operating reliability and safety.

The following information must be observed prior to any welding work:

- The machine must be uncoupled from the towing vehicle prior to any welding work.
- Welding work should only be carried out by an experienced/qualified personnel or consult a Stanhay dealer.
- Always fasten the earth terminal of the welding machine to the part to be welded or to a point in the immediate vicinity of the welding point.



### **DANGER!**

**Risk of injury! Serious injuries and death possible!**

Incorrectly carried out welding work compromises the machine's operating reliability and safety. Serious accidents and machine damage may result.

- Have welding work only carried out by experienced qualified personnel.

# 10.0 GENERAL MAINTENANCE

## 10.6 TIGHTENING TORQUES FOR SCREW CONNECTIONS IN GENERAL

Check all screws and nuts regularly for tight fit. When replacing screws and nuts, make sure that corresponding fastening elements are of the same or a higher quality grade. Make sure that threads are clean and screws are correctly inserted. This prevents damage during tightening.

The necessary tightening torques can be found in the table. The screw's strength class is specified on the screw head.



The tightening torques given in the table below do not apply when a different torque is specified for certain screws and nuts.

TIGHTENING TORQUES				
		Strength Class		
		8.8*	10.9*	12.9*
Thread Size (mm)	Spanner Size (mm)	Tightening Torque (Nm)		
M6	10	9.5	14	16.5
M8	13	23	34	40
M10	17	46	68	79
M12	19	79	117	135
M14	22	125	185	215
M16	24	195	280	330
M18	27	280	390	460
M20	30	390	560	650
M22	32	530	750	880
M24	36	670	960	1120
M27	41	1000	1400	1650
M30	46	1350	1900	2250

\* The strength class of the nut must also be taken into account when a through-type screw connection is concerned. The tightening torque of the lesser strength class is to be used when nut and screw are of different strength classes.

- 8.8 for the screw corresponds to strength class 8 of the nut
- 10.9 for the screw corresponds to strength class 10 of the nut
- 12.9 for the screw corresponds to strength class 12 of the nut

# 10.0 GENERAL MAINTENANCE

---

## 10.7 LUBRICATION POINTS

- Remove dirt from lubricating nipples prior to applying grease.
- Do not apply too much grease to the bearings/guides.
- Remove excess grease escaping from bearings.

### 10.7.1 LUBRICANT RECOMMENDATION

To ensure the perfect operation at all times, it is recommended to use NLGI class 2 greases with EP additives; compatible with plastic materials, NBR elastomers, copper and copper alloys.

**DANGER!**

Rotating or moving machine parts can pull in or sever limbs. Unsecured machines on wheels can roll over persons - danger of injury!

- Switch off the engine prior to any work which requires staying in the danger zone.
- Secure the machine against rolling away!

**DANGER!**

There is a risk of injury at dangerous machine parts without protective cover!

- All protective devices or covers that were removed must be properly reinstalled once the adjustment or repair work has been completed.

### 10.7.2 CHAINS

It is recommended that all drive chains on either the landwheel or row unit have a dry lubricant applied after every week or as required. Do not use grease or other wet lubricant as this may attract dust and grit into the workings of the machine.

# 11.0 LANDWHEEL MAINTENANCE

## 11.1 CHECKING THE WHEELS/TYRES

Defective tyres and/or the wrong tyre pressure reduce the operating safety.

Only carry out the following checks when the engine is switched off. Pay attention that the machine is safely parked and secured against rolling away.

- Check the tyres daily for signs of damage or obvious low pressure – tyres must be inflated to 48psi to maintain correct seed spacing.
- Measure the tyre pressure with accurate test equipment.

**DANGER!**

There is a risk of bursting if the tyre pressure is too high!

If a tyre bursts during inflating, flying parts can hit and injure persons in the vicinity.

- Do not exceed the specified air pressure when inflating the tyres!

**DANGER!**

The risk of accidents is greatly increased if the tyres are under inflated!

Under inflation can lead to damage of the tyres and incorrect seed spacing. If the tyre pressure is too low, the tyre may come off the wheel rim whilst in operation!

- Check the tyres daily for signs of obvious low pressure!
- Measure the tyre pressure with accurate test equipment once a week!

## 11.2 MAINTENANCE/REPAIR WORK ON WHEELS/TYRES

The following must be observed during maintenance or repair work:

- Do not work on the wheels unless the engine is switched off. Remove the ignition key.
- Prior to any work on the wheels, attention must be paid that the machine is securely parked and has been secured against rolling away (apply wedges if necessary).
- Working under an unpropped machine is prohibited.
- There is a risk of bursting if the tyre pressure is too high! Always observe the correct tyre pressure.



# 11.0 LANDWHEEL MAINTENANCE

## 11.3 TIGHTENING WHEEL NUTS/ WHEEL BOLTS

Only carry out work on the wheel nuts/wheel bolts when the engine is switched off. Pay attention that the machine is safely parked and secured against rolling away.

Sequence for tightening the wheel nuts/wheel bolts

- Always tighten the wheel nuts/wheel bolts with the specified tightening torque.

The firm seating of the screw connections on the landwheels must be checked at the following intervals:

- Before the first use under load
- After the first use under load
- After 50 operating hours
- After 100 operating hours
- Thereafter every 200 operating hours

Screw type: M14x1.5 8.8

Number of screws: 5

Tightening torque: 125 Nm



Tighten the wheel nuts diagonally using a torque spanner.

## 11.4 LANDWHEEL GREASE POINTS

Grease each individual landwheel at point (A) shown below. One lubrication point per landwheel.

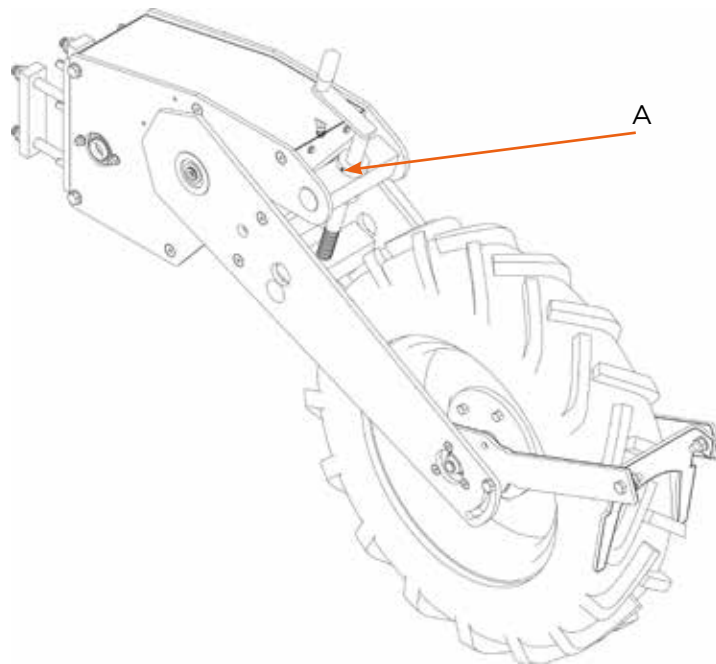

# 12.0 TOOLBAR MAINTENANCE

## 12.1 STACKER GREASE POINTS

Grease the toolbar as instructed by the diagram below. The greasing points are specified by points (G). There are 4 lubrication points per side.

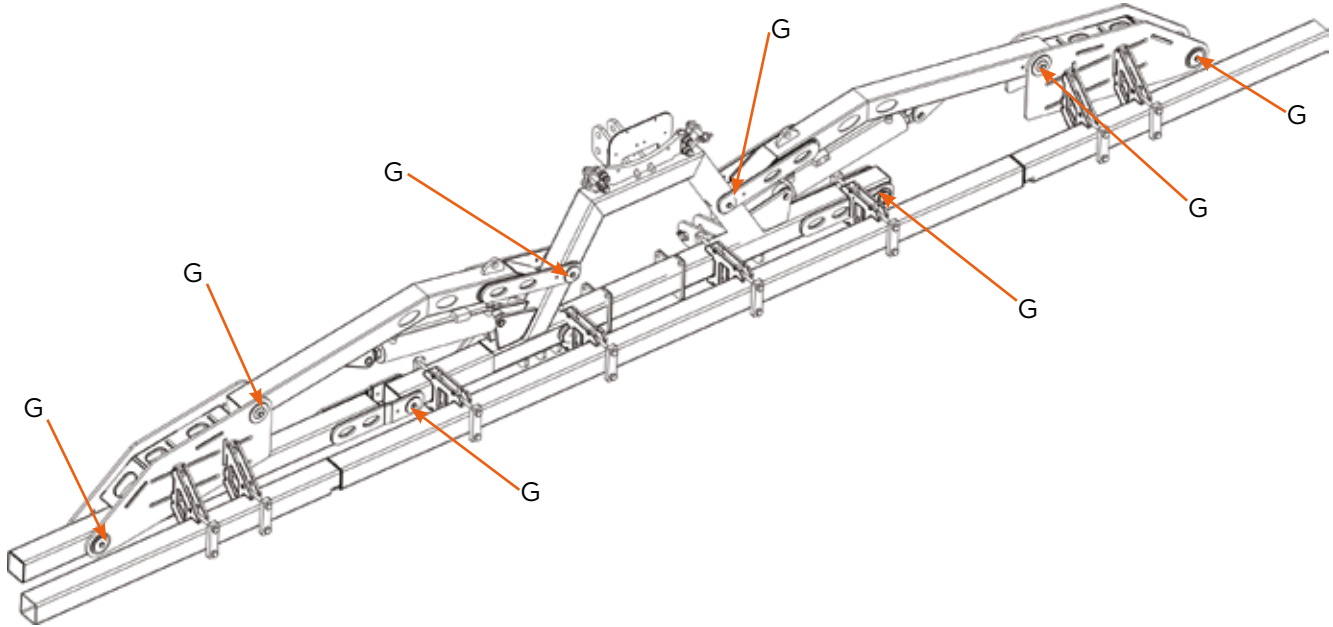

# 13.0 ROW UNIT MAINTENANCE

---

Seven row units use maintenance free bearings at all pivot points meaning no periodic maintenance is required. Drive chains require maintenance via thin film lubrication only.



**DO NOT OIL CHAINS.** Oil will attract dust and encourage premature chain wear.

# 14.0 LOADING WORK

For loading and unloading of the machine using an overhead crane, the lifting points must be located where the symbol of the lifting hook is shown. Only use suitable lifting equipment with adequate load-carrying capabilities.

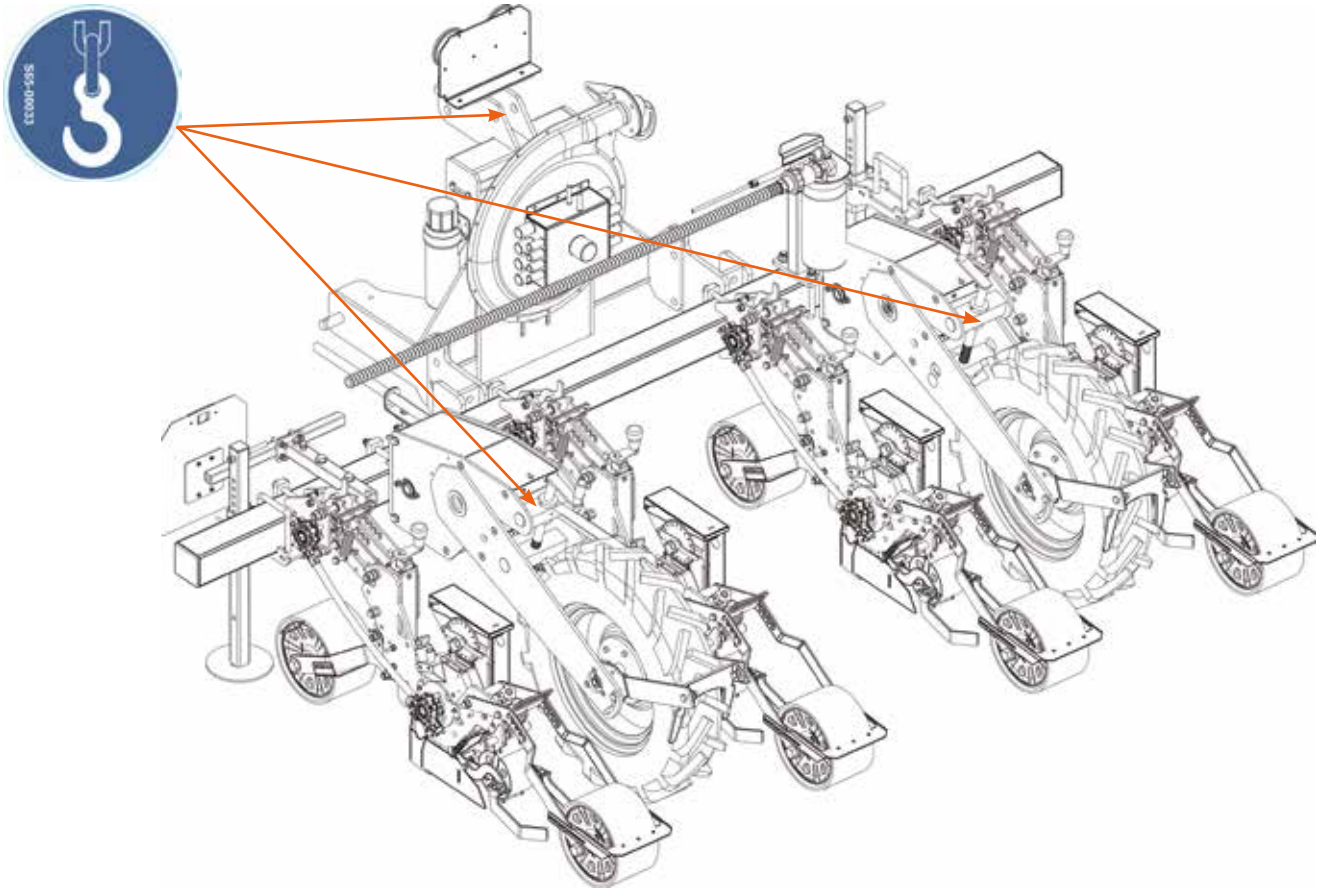

If the machine is loaded onto a transport vehicle, the machine must be secured on the transport vehicle by means of strapping to stop the machine from moving on the transport vehicle.



**DANGER!**

**Risk of injuries by dropping machines or machine components!**

A lifted load can drop when a lifting device or any lifting apparatus fails.

- Never stand or work under suspended loads. Instruct all people in the vicinity of loading the drill to keep clear of the danger zone.



**DANGER!**

**Risk of crushing by swinging or dropping load!**

Suspended loads have a risk of swinging or dropping when being loaded or unloaded. People within the vicinity of the suspended load are at risk of being hit by the suspended load.

- Attach the machine to the correct loading points only.
- Attachment of the loads and the use of lifting equipment should only be entrusted by competent operators.

# 15.0 DECOMMISSIONING AND DISPOSAL

## 15.1 DECOMMISSIONING

If the end of the useful life of machine or its components is reached and these are handed over for scrapping, the components must be disposed of in the correct manner. At the same time the regulations of the local authorities must be adhered to.

## 15.2 DISPOSAL

The service fluids in the machine require a special type of disposal and may not get into the environment. Further information with regards to waste disposal can be gathered from the local authorities, the Stanhay dealer and Stanhay service. Do not dispose of the product carrying the symbol below (domestic waste only) at the end of their lifetime.

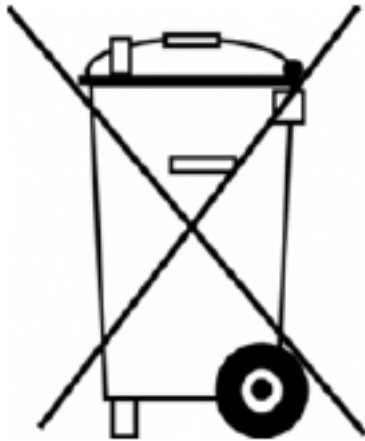

- Recycle materials used and carrying the symbol above according to their identification.
- Do not dispose of any packaging material via the domestic waste, instead recycle the materials.
- Any plastics with their material data shown on them can be recycled.
- Used batteries contain contaminants and must be taken back to the distributor, duly disposed of or handed in at a collection point. Do not dispose of used batteries via domestic waste.
- Treat service fluids such as oils, hydraulic fluids, brake fluids or fuels as special waste and dispose of in due form.
- Adhere to all country regulations and local authorities regarding recycling and disposal.

# 16.0 TECHNICAL DATA

<b>PART</b>	<b>SEVEN</b>
Planter Type	Cell Wheel
Seed Type	Regular Shaped + Pelleted
Multi-line Capability	Single Line
Hopper Capacity (Litres)	12
Toolbar	100mm or 180mm Square
Minimum Seed Spacing	30mm
Min/Max Seed Size	1mm-10mm
Min/Max Number of Rows Per Machine	2-18+
Minimum Row Spacing	250mm
Minimum Line Spacing	N/A
Approx Row Unit Weight (Kg)	58
Row Unit Length (mm)	1400
Depth Control	Incremental 2.5mm Steps
Coverer Options	Arm/Drag
Wheel Options	Stainless/Cage/Rubber
Seed Press Wheels Available	Yes
Row Unit Down Force Adjustment	Yes
Rear Wheel Down Force Adjustment	Yes
Drive System	12 Speed Chain Drive
Tractor Requirement	Small or Large Tractor
Linkage Category	CAT 2/3

<b>PART</b>	<b>APPROXIMATE WEIGHT (kg)</b>
100 Toolbar 3000mm long	45
Geared Landwheel	106
SEVEN Row Unit	58
Parking Stand	7.5
Stacking Frame	450
Support Landwheel	100
Ancillaries (per 1m)	0.5

# 17.0 SEED RATE CALCULATIONS

## 17.1 BED SYSTEMS



Average Seed Spacing (mm) =

$$\frac{10,000,000 \times \text{Total Lines on Bed}}{\text{Tractor Wheel Track (m)} \times \text{Seeds/Hectare}}$$

Seeds/Hectare =

$$\frac{10,000,000 \times \text{Total Lines on Bed}}{\text{Tractor Wheel Track (m)} \times \text{Average seed spacing (mm)}}$$

Average Seed Spacing (in) =

$$\frac{6,272,640 \times \text{Total Lines on Bed}}{\text{Tractor Wheel Track (in)} \times \text{Seeds/Acre}}$$

Seeds/Acre =

$$\frac{6,272,640 \times \text{Total Lines on Bed}}{\text{Tractor Wheel Track (in)} \times \text{Average seed spacing (in)}}$$

## 17.2 FIELD SYSTEMS



Average Seed Spacing (mm) =

$$\frac{1,000,000,000 \times \text{Lines/Row}}{\text{Row Width (cm)} \times \text{Seeds/Hectare}}$$

Seeds/Hectare =

$$\frac{1,000,000,000 \times \text{Lines/Row}}{\text{Row Width (cm)} \times \text{Average seed spacing (mm)}}$$

Average Seed Spacing (in) =

$$\frac{6,272,640 \times \text{Lines/Row}}{\text{Row Width (in)} \times \text{Seeds/Acre}}$$

Seeds/Acre =

$$\frac{6,272,640 \times \text{Lines/Row}}{\text{Row Width (in)} \times \text{Average seed spacing (in)}}$$

# 18.0 SPACING CHARTS

## 18.1 SEED SPACING CHART FOR SEVEN (19-24 PRIMARY DRIVE)

GEAR SET UP	21 HOLE SEED DISC		23 HOLE SEED DISC		27 HOLE SEED DISC		32 HOLE SEED DISC		42 HOLE SEED DISC		54 HOLE SEED DISC		64 HOLE SEED DISC		TRACTOR FORWARD SPEED TO ROTATE SEED DISC AT 25RPM	
	mm	inch	mm	inch	mm	inch	mm	inch	mm	inch	mm	inch	mm	inch	KPH	MPH
24/15	115	4.53	105	4.13	90	3.54	76	2.99	58	2.28	45	1.77	39	1.54	3.9	2.4
24/16	123	4.84	112	4.41	96	3.78	81	3.19	62	2.44	48	1.89	40	1.57	4.1	2.5
24/17	131	5.16	119	4.69	102	4.02	86	3.39	65	2.56	51	2.01	43	1.69	4.4	2.7
24/18	138	5.43	126	4.96	108	4.25	91	3.58	69	2.72	54	2.13	45	1.77	4.7	2.9
24/19	146	5.75	133	5.24	114	4.49	96	3.78	73	2.87	57	2.24	48	1.89	4.9	3.0
24/20	154	6.06	140	5.51	120	4.72	101	3.98	77	3.03	60	2.36	50	1.97	5.2	3.2
24/21	162	6.38	148	5.83	126	4.96	106	4.17	81	3.19	63	2.48	53	2.09	5.4	3.4
24/22	169	6.65	155	6.10	132	5.20	111	4.37	85	3.35	66	2.60	56	2.20	5.7	3.5
17/16	174	6.85	159	6.26	135	5.31	114	4.49	87	3.43	68	2.68	57	2.24	5.8	3.6
17/17	185	7.28	169	6.65	144	5.67	121	4.76	92	3.62	72	2.83	61	2.40	6.2	3.9
17/18	196	7.72	179	7.05	152	5.98	128	5.04	98	3.86	76	2.99	64	2.52	6.6	4.1
17/19	206	8.11	188	7.40	161	6.34	135	5.31	103	4.06	80	3.15	68	2.68	7.0	4.3
17/20	217	8.54	198	7.80	169	6.65	143	5.63	109	4.29	84	3.31	71	2.80	7.3	4.5
17/21	228	8.98	208	8.19	177	6.97	150	5.91	114	4.49	89	3.50	75	2.95	7.7	4.8
17/22	239	9.41	218	8.58	186	7.32	157	6.18	119	4.69	93	3.66	78	3.07	8.0	5.0
13/15	213	8.39	195	7.68	166	6.54	140	5.51	107	4.21	83	3.27	70	2.76	7.2	4.5
13/17	241	9.49	220	8.66	188	7.40	158	6.22	121	4.76	94	3.70	79	3.11	8.1	5.0
13/18	256	10.08	233	9.17	199	7.83	168	6.61	128	5.04	99	3.90	84	3.31	8.6	5.3
13/19	270	10.63	246	9.69	210	8.27	177	6.97	135	5.31	105	4.13	89	3.50	9.1	5.7
13/20	284	11.18	259	10.20	221	8.70	186	7.32	142	5.59	110	4.33	93	3.66	9.6	6.0
13/21	298	11.73	272	10.71	232	9.13	196	7.72	149	5.87	116	4.57	98	3.86	10.0	6.2
13/22	312	12.28	285	11.22	243	9.67	205	8.07	156	6.14	122	4.80	103	4.06	10.6	6.6
11/15	252	9.92	230	9.06	196	7.72	165	6.50	126	4.96	98	3.86	83	3.27	8.5	5.3
11/18	302	11.89	276	10.87	235	9.25	198	7.80	151	5.94	118	4.65	99	3.90	10.2	6.3
11/19	319	12.56	291	11.46	248	9.76	209	8.23	159	6.26	124	4.88	105	4.13	10.7	6.6
11/20	336	13.23	307	12.09	261	10.28	220	8.66	168	6.61	131	5.16	110	4.33	11.3	7.0
11/21	353	13.90	322	12.68	274	10.79	231	9.09	176	6.93	137	5.39	116	4.57	11.9	7.4
11/22	369	14.53	337	13.27	287	11.30	243	9.57	185	7.28	144	5.67	121	4.76	12.5	7.8



# NOTES

A series of horizontal dotted lines for taking notes.



STANHAY WEBB LTD  
BCS HOUSE  
PINFOLD ROAD  
BOURNE  
PE10 9HT  
UK

[WWW.STANHAY.COM](http://WWW.STANHAY.COM)

S66-00007

VERSION 1.1 JULY 2020



Place dealer address here: