

# REPAIR PARTS

B71-35B Vegetable drill

B91-92B Vegetable drill with floating hitch

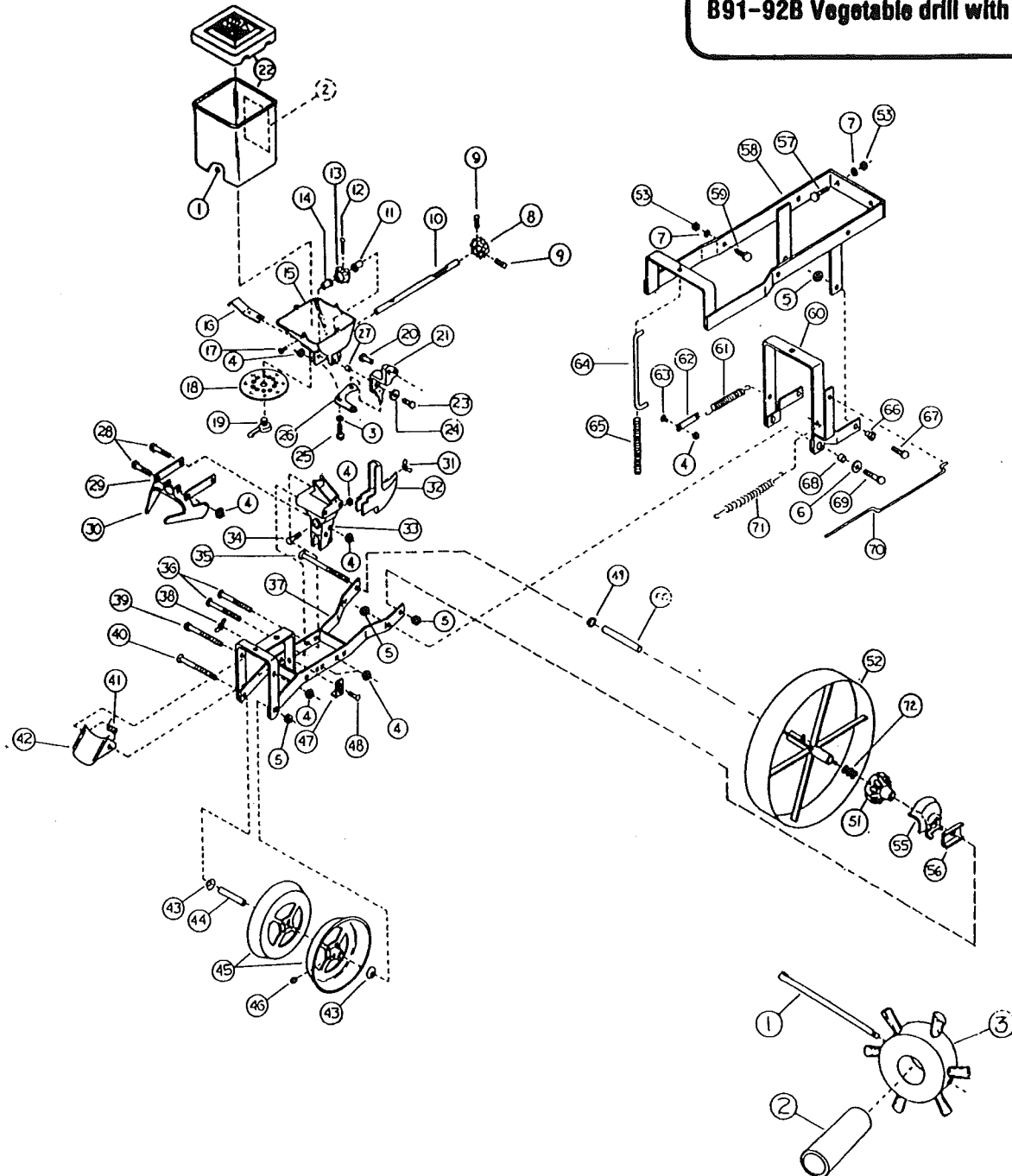

BUNDLE B10-039X: NARROW BRUSH FEED WHEEL

FOR SINGLE HOPPER

BUNDLE B96-084X: WIDE BRUSH FEED WHEEL

FOR DOUBLE HOPPER

REF. NO.	PART NO.	DESCRIPTION	NO. REQ.
1	001-3355	Cotter Pin 1/8" x 2"	1
2	P00-521A	Ferrule	1
3	P96-083	Brush, Narrow Feed Wheel	1
	P96-084	Brush, Wide Feed Wheel (Not Shown)	1

<u>DIAGRAM NUMBER</u>	<u>PART NUMBER</u>	<u>DESCRIPTION</u>	<u>NUMBER PER ASSEMBLY</u>
1	001-1047	Washer, 1/8 Pop Rivet .312 x .129 x .030	12
2	003-5598	Decal, Powell/Cole Planet Jr.	1
3	001-1001	Washer, Flat 1/4", ZP USS STD. Wrought	1
4	001-0054	Locknut, Hex ZP 1/4"	8
5	001-0055	Locknut, Hex ZP 3/8"	6
6	001-1002	Washer, Flat 5/16" ZP USS STD Wrought	2
7	001-1254	Washer, Lock ZP 1/2"	4
8	004-4605	Gear, Pinion Gear (Order 012-0250 Kit)	1
9	001-2751	Screw, Set Sq. Hd. ZP 1/4 x 1/2	2
10	016-5000	Shaft, Drive	1
11	P00-519A	Bushing, Nylon 13/16" Lg.	1
12	001-3352	Pin, Cotter ZP, 1/8 x 1-1/4	1
13	POK-817T	Plastic Feed Wheel	1
14	P00-520A	Bushing, Nylon 1-5/16" Lg.	1
15	POK-717C	Base, Hopper	1
16	B00-6542-X	Latch, Seed Plate	1
17	001-3509	Rivet, Pop 1/8" x .400 Lg. Aluminum	12
18	P00-5458	Plastic Seed Plate 1-13	1
	P00-5458M	Metal Seed Plate 1-13	1
	P00-5459	Plastic Seed Plate 14-26	1
	P00-5459M	Metal Seed Plate 14-26	1
	P00-5460	Plastic Seed Plate 27-39	1
	P00-5460M	Metal Seed Plate 27-39	1
	B21-517	Set of (3) Three Metal Seed Plates (1-13), (14-26), (27-39)	1
19	POK-740	Cam Casting	1
20	P21-319	Pin, Clevis	1
21	POK-719A	Lever, Seed Shut-Off	1
22	P21-458	Hopper and Lid Assembly/Plastic, Square	1
	B00-7559-B	Plastic Hopper and Shaft Assembly	1
23	001-2035N	Screw, Cap Hex Hd NY-Lock 5/16" x 1"	1
24	001-1002	Washer, Flat 5/16" ZP USS STD Wrought	1
25	001-2004	Screw, Cap HH ZP 1/4-20NC x 3/4"	1
26	P00-5441	Shut-Off, Seed	1
27	P21-270	Bushing	1
28	001-2012	Screw, Cap HH ZP 1/4-20NC x 2-1/2"	2
29	P00-5482	Arm, Cover	2
30	B00-6540-X	Cover, Seed, W/Arm	1
31	001-0100	Nut, Wing, ZP 1/4-20	1
32	BOK-712	Shoe, Drill	1
33	POK-835	Seed Spout	1
34	001-2554	Bolt, Crg., ZP 1/4-20NC x 1-1/2"	1
35	001-2616	Bolt, Crg 3/8-16NC x 7	1

<u>DIAGRAM NUMBER</u>	<u>PART NUMBER</u>	<u>DESCRIPTION</u>	<u>NUMBER PER ASSEMBLY</u>
36	001-2565	Bolt, Crg., ZP 1/4-20NC x 4-1/2"	2
37	P21-272	Weldment, Main Frame	1
38	001-0100	Nut, Wing, ZP 1/4"-20	1
39	001-2020	Screw, Cap HH ZP 1/4-20NC x 5"	1
40	001-2611	Bolt, Crg., ZP 3/8-16NC x 5"	1
41	P00-7207	Coil Spring	1
42	P00-5541	Scraper	1
43	P00-3806	Cap Dust	2
44	P00-5473	Ferrule, Roller	1
45	POK-894	Rear Roller Cast Wheel	2
46	003-8523	Fitting, Grease Straight 1/4" Drive	2
47	P00-5486	Piece, Stop	1
48	001-2551	Bolt, Crg., 1/4" x 3/4"	1
49	P00-3806	Cap, Dust	1
50	P00-4910	Ferrule, Wheel	1
51	POK-713C	Cast Wheel Hub	1
52	P21-234A	Drive Wheel Weld Assembly For Iron Hub	1
	B06-533X-A	Kit, Drive Wheel	1
53	001-0009	Nut, Hex ZP 1/2-13NC	4
54			
55	POK-721C	Gear Cover	1
56	P21-298	Spacer	1
57	001-2121	Screw, Cap HH ZP 1/2-13NC x 1-1/2	2
58	P21-278	Weldment, Floating Hitch	1
59	001-2119	Screw, Cap HH 1/2-13NC x 1	2
60	P09-179X-A	Ball and Link Weld Assembly	1
61	P00-5587	Coil Spring	1
62	P21-301	Tension Spring Adjuster	1
63	001-2551	Bolt, Crg., ZP 1/4-20NC x 3/4	1
64	P21-284	Pin, Spring Guide	1
65	P21-152	Coil Spring	1
66	POT-227	Ferrule	2
67	001-2066	Screw, Cap HH ZP 3/8-16NC x 1-1/4	2
68	PSD-42	45/64" x 13/32" x 21/32" Hardened Bushing	2
69	001-2067	Machine Bolt, 3/8" x 1-1/2"	2
70	P21-288	Arm, Seed Shut-Off	1
71	P21-289	Coil Spring	1
72	003-8808	Spring	1

**B21-259 MOUNTS TO 2½" CORNER MOUNTED TOOL BAR, ADJUSTABLE**

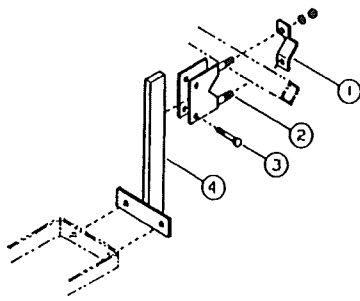

BUNDLE B21-259

REF. NO.	PART NO.	DESCRIPTION	NO. REQ.
1	P46-324	Clamp Plate	1
2	P46-321	Clamp Assembly	1
3	001-2124-5	Machine Bolt 1/2" x 2-1/4" Grade 5	2
4	B21-292	Standard Weld Assembly	1

**B21-261 MOUNTS TO 2½" TOOL BAR, ADJUSTABLE**

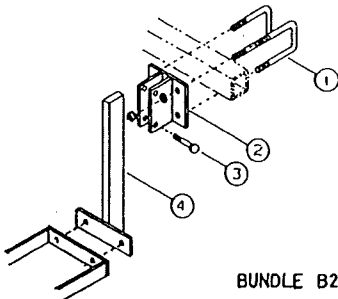

BUNDLE B21-216

REF. NO.	PART NO.	DESCRIPTION	NO. REQ.
1	B47-126	U-Bolt	2
2	B51-194	Shank Clamp Assembly	1
3	001-2124-5	Machine Bolt 1/2" x 2-1/4" Grade 5	2
4	B21-292	Standard Weld Assembly	1

**B21-263 MOUNTS TO 4" TOOL BAR, ADJUSTABLE**

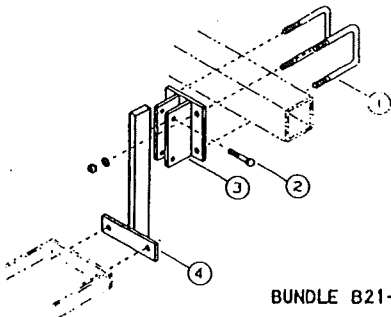

BUNDLE B21-263

REF. NO.	PART NO.	DESCRIPTION	NO. REQ.
1	B47-127	U-Bolt	2
2	001-2124-5	Machine Bolt 1/2" x 2-1/4" Grade 5	2
3	B51-194	Shank Clamp Assembly	1
4	B21-292	Standard Weld Assembly	1

**REPAIR PARTS**

- B21-259 Mounting bracket, 2½" corner mounted tool bar
- B21-261 Mounting bracket, 2½" tool bar
- B21-263 Mounting bracket, 4" tool bar
- B21-264 Mounting bracket, Rear Angle Frame Cultivator
- B21-305 Mounting bracket, Cat. 1, 3-pt. hitch
- B47-074 Mounting bracket, Cat. 0, 3-pt. hitch

**B21-264 MOUNTS TO REAR ANGLE CULTIVATORS, ADJUSTABLE**

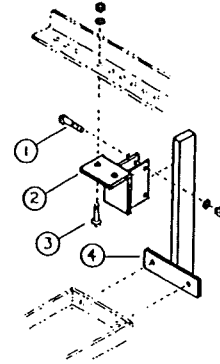

BUNDLE B21-264

REF. NO.	PART NO.	DESCRIPTION	NO. REQ.
1	001-2124-5	Machine Bolt 1/2" x 2-1/4" Grade 5	2
2	B51-130	Clamp (Includes 1,2,3)	1
3	001-2094-5	Machine Bolt 7/16" x 1-1/2" Grade 5	2
4	B21-292	Standard Weld Assembly	1

- B21-305A MOUNTS TO TRACTORS WITH CAT. "1", 3- POINT HITCH
- B47-074 MOUNTS TO TRACTORS WITH CAT. "0", 3- POINT HITCH

