

# SHAYER

## OPERATOR'S MANUAL

MODEL SC-50  
**3-Point  
StumpBuster™**

and

MODEL SC-50-H  
**Hydraulic  
StumpBuster™**

Shaver Manufacturing Co.  
Graettinger, Iowa 51342 • (712) 859-3293



## SC-50 3-POINT STUMP CUTTER SPECIFICATIONS

Weight .....	1020 lbs.
Cutting wheel diameter .....	34 inches
Cutting wheel speed .....	895 rpm
Cutting arc .....	55 degrees
Hub torque .....	450 lbs.-ft.
Required power source .....	35 to 100 HP
Cutting teeth .....	25 carbide steel teeth
Maximum stump height .....	24 inches
Maximum cutting depth .....	12 inches

## SC-50-H HYDRAULIC STUMP CUTTER SPECIFICATIONS

Weight .....	1140 lbs.
Cutting wheel diameter .....	34 inches
Cutting wheel speed .....	795 rpm
Cutting arc .....	55 degrees
Hub torque .....	450 lbs.-ft.
Required power source .....	25 to 40 GPM High Flow
Cutting teeth .....	25 carbide steel teeth
Maximum stump height .....	24 inches
Maximum cutting depth .....	12 inches

## THE PACKING LIST

The SC-50 StumpBuster™ is shipped in one unit, ready to mount on a Category II Tractor. The Operator's Kit is attached in a Plastic Bag and contains:

SC-50-15	Carbide Tooth (3)
SC-50-83	Category I Pin (2)
SC-50-Opman	Operator's Manual & Warranty Card

The SC-50-H Hydraulic StumpBuster™ is shipped in one unit ready to mount a skidsteer loader with the standard universal mounting bracket. The Operator's Kit is attached in a Plastic Bag and contains:

SC-50-15	Carbide Tooth (3)
SC-50-Opman	Operator's Manual & Warranty Card



# SAFETY RULES

**ATTENTION! BECOME ALERT! YOUR SAFETY IS INVOLVED!**



Safety is a primary concern in the design and manufacture of our products. Unfortunately, our efforts to provide safe equipment can be wiped out by an operator's single careless act.

In addition to the design and configuration of equipment, hazard control and accident prevention are dependent upon the awareness, concern, judgement, and proper training of personnel involved in the operation, transport, maintenance and storage of equipment.

It has been said "The best safety device is an informed, careful operator." We ask you to be that kind of operator.

## TRAINING

- Safety instructions are important! Read all attachment and power unit manuals; follow all safety rules and safety decal information. (Replacement manuals are available from dealer or, in the United States and Canada, call 1-712-859-3293.) Failure to follow instructions or safety rules can result in serious injury or death.
- If you do not understand any part of this manual and need assistance, see your dealer.
- Know your controls and how to stop engine and attachment quickly in an emergency.
- Operator's must be instructed in and be capable of the safe operation of the equipment, its attachments, and all controls. Do not allow anyone to operate this equipment without proper instructions.
- Keep hands and body away from pressurized lines. Use paper or cardboard, not hands or other body parts to check for leaks. Wear safety goggles. Hydraulic fluid under pressure can easily penetrate skin and will cause serious injury or death.
- Make sure that all operating and service personnel know that if hydraulic fluid penetrates skin, it must be surgically removed as soon as possible by a doctor familiar with this form of injury or gangrene, serious injury, or death will result. **CONTACT A PHYSICIAN IMMEDIATELY IF FLUID ENTERS SKIN OR EYES. DO NOT DELAY.**
- Never allow children or untrained persons to operate equipment.

## PREPARATION

- Check that all hardware is properly installed.
- Always wear relatively tight and belted clothing to avoid entanglement in moving parts. Wear sturdy, rough-soled work shoes and protective equipment for eyes, hair, hands, hearing, and head.
- Make sure attachment is properly secured, adjusted, and in good operating condition.
- Make sure spring-activated locking pin or collar slides freely and is seated firmly in tractor PTO spline groove.
- Power unit must be equipped with ROPS or ROPS cab and seat belt. Keep seat belt securely fastened. Falling off power unit can result in death from being run over or crushed. Keep foldable ROPS systems in "locked up" position at all times.
- Make sure all safety decals are installed and understood. Replace if damaged. Safety decals are pictured in this manual on pages 6 and 7.
- Make sure shields and guards are properly installed and in good condition. Replace if damaged.

## OPERATION

- Do not allow bystanders in the area when operating, attaching, removing, assembling, or servicing equipment.
- Consult local utilities before working. Know location of all underground cables, pipelines, overhead wires, and other hazards in working area and avoid contact.
- Do not put stump cutter into service unless cutting teeth edges are intact and in good repair.
- Do not put stump cutter into service unless all shields and guards are in place and in good condition. Replace if damaged.
- Keep bystanders away from equipment.
- Do not operate equipment while under the influence of alcohol or drugs.
- Operate only in daylight or good artificial light.
- Avoid contact with electrical wires.
- Do not raise the stump cutter more than 24" above ground level.



# SAFETY RULES

ATTENTION! BECOME ALERT! YOUR SAFETY IS INVOLVED!



## OPERATION (continued)

- Keep hands, feet, hair, and clothing away from equipment while engine is running. Stay clear of all moving parts.
- Always comply with all state and local lighting and marking requirements.
- Never allow riders on power unit or attachment.
- Always sit in power unit seat when operating controls or starting engine. Securely fasten seat belt, place transmission in neutral, engage brake, and ensure all other controls are disengaged before starting power unit engine.
- **NEVER GO UNDERNEATH EQUIPMENT.** Never place any part of the body underneath equipment or between moveable parts even when the engine has been turned off. Hydraulic system leak down, hydraulic systems failures, mechanical failures, or movement of control levers can cause equipment to drop or rotate unexpectedly and cause severe injury or death.
- For Model SC-50, shift tractor into park or neutral and set brakes before engaging the PTO shaft or grinding. For Model SC-50-H, put skid loader into park or neutral and set brake before engaging hydraulics.
- Do not operate on steep slopes. Do not stop, start, change directions suddenly, or use excessive speed on steep slopes.
- Before your or dealer performs service or maintenance, lower equipment to ground and block securely. Turn off engine and remove key. On SC-50, disconnect PTO shaft from tractor. On SC-50-H, disconnect the (2) hydraulic hoses from the skid loader.
- Look in ALL directions to make sure the area is clear and safe before operating equipment.

## MAINTENANCE

- Service and maintenance work not covered in OWNER SERVICE must be done by a qualified dealership. Special skills, tools, and safety procedures may be required. Failure to follow these instructions can result in serious injury or death.
- On the SC-50 stump cutter, keep fingers out of shield access slots to prevent injury when lubricating the PTO shaft.
- Keep all persons away from operator control area while performing adjustments, service, or maintenance.
- Tighten all bolts, nuts and screws to torque chart specifications. Check that all cotter pins are installed securely to ensure equipment is in a safe condition before putting unit into service.
- Make sure shields and guards are properly installed and in good condition. Replace if damaged.
- Make sure attachment is properly secured, adjusted, and in good operating condition.
- Never perform service or maintenance with engine running.
- Do not modify or alter or permit anyone else to modify or alter the equipment or any of its components in any way. This will void the warranty.
- Always wear relatively tight and belted clothing to avoid entanglement in moving parts. Wear sturdy, rough-soled work shoes and protective equipment for eyes, hair, hands, hearing, and head.
- Do not allow bystanders in the area when operating, attaching, removing, assembling, or servicing equipment.



## SAFETY RULES

**ATTENTION! BECOME ALERT! YOUR SAFETY IS INVOLVED!**



### STORAGE

- Block equipment securely for storage.
- Do not climb or lean on equipment stored on stand.

### STORAGE (continued)

- Keep children and bystanders away from storage area.
- Make sure stabilizer legs and jack stand leg are secure on the ground.



## WARNING

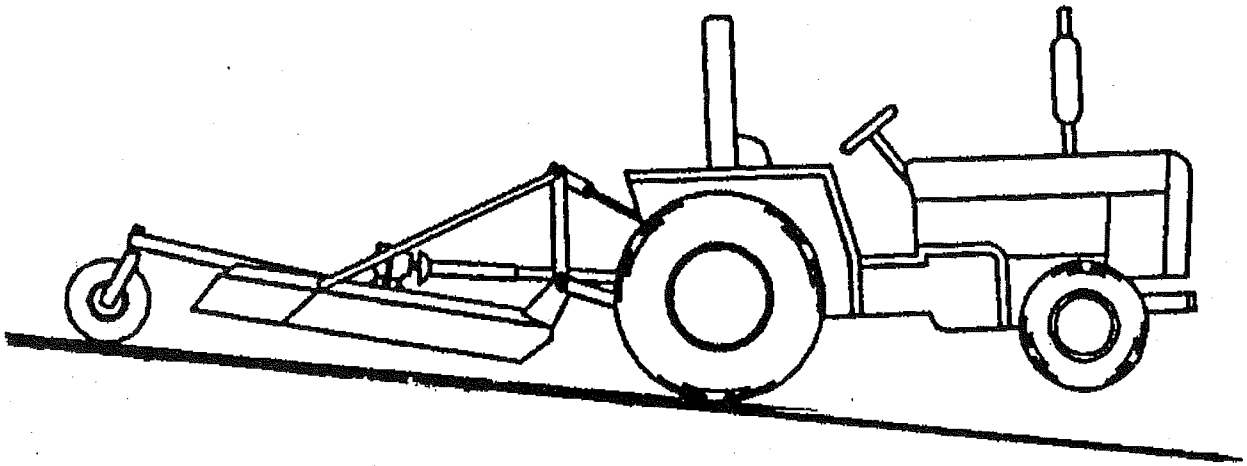

- A minimum 20% of tractor and equipment weight must be on the tractor front wheels when attachments are in transport position. Without this weight, tractor could tip over, causing personal injury or death. The weight may be attained with a loader, front wheel weights, ballast in tires or front tractor weights. Weigh the tractor and equipment. Do not estimate.

# SAFETY & INSTRUCTIONAL DECALS



**⚠ WARNING**

HIGH PRESSURE HYDRAULIC OIL LEAKS CAN PENETRATE SKIN

- CHECK FOR LEAKS WITH CARDBOARD; NEVER USE HAND.
- BEFORE LOOSENING FITTINGS: LOWER LOAD, RELEASE PRESSURE, AND BE SURE OIL IS COOL.
- CONSULT PHYSICIAN IMMEDIATELY IF SKIN PENETRATION OCCURS. SKIN PENETRATION CAN RESULT IN SERIOUS INJURY AND GANGRENE.

MS - 511

MS - 171

**⚠ DANGER**



**GUARD MISSING. DO NOT OPERATE.**

**⚠ DANGER**



**GUARD MISSING. DO NOT OPERATE.**

**⚠ DANGER**

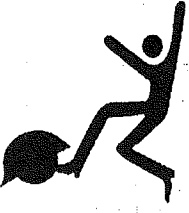

**⚠ DANGER**

OPERATE FROM TRACTOR SEAT ONLY

KEEP OTHERS AWAY FROM STUMP CUTTER WHEN IN OPERATION

CONTACT MAY RESULT IN INJURY OR DEATH

MS - 501 - A

**⚠ DANGER**

**SHIELD MISSING**

DO NOT OPERATE  
PUT SHIELD ON.

MS - 505

**IMPORTANT**

Gearbox does NOT contain oil.  
Fill with 6 pints of SAE 90 oil  
**BEFORE OPERATING**

↓

MS - 507

**⚠ WARNING**

DO NOT EXCEED PTO SPEED OF 540 RPM

PTO speeds higher than 540 RPM can cause equipment failure and personal injury.

MS - 506

**⚠ WARNING**

DO NOT EXCEED 40 G.P.M. HYDRAULIC FLOW HIGHER THAN 40 G.P.M. CAN CAUSE EQUIPMENT FAILURE OR PERSONAL INJURY.

MS - 508

**⚠ DANGER**

- USE STUMP CUTTER FOR ITS INTENDED PURPOSE ONLY.
- DO NOT RAISE CUTTER HIGHER THAN 24 INCHES FROM GROUND LEVEL.
- RAISING UNIT HIGHER MAY RESULT IN DEATH OR SERIOUS INJURY.

MS - 504

**⚠ DANGER**



**ROTATING DRIVELINE CONTACT CAN CAUSE DEATH**

**KEEP AWAY!**

DO NOT OPERATE WITHOUT-

- ALL DRIVELINE GUARDS, TRACTOR AND EQUIPMENT SHIELDS IN PLACE
- DRIVELINES SECURELY ATTACHED AT BOTH ENDS
- DRIVELINE GUARDS THAT TURN FREELY ON DRIVELINE

SC - 50 - 414

**⚠ DANGER**



**FLYING DEBRIS FROM CUTTING WHEEL**

Keep away from stump cutter while in operation.

Contact may cause injury.

MS - 503

**⚠ WARNING**



**CRUSHING AND PINCHING HAZARD**

- Be extremely careful handling various parts of the hitching mechanism. They are heavy and hands, fingers, feet, and other body parts could be crushed or pinched between tractor and implement.
- Operate tractor controls from tractor seat only.
- Do not stand between tractor and implement when tractor is in gear.
- Make sure parking brake is engaged before going between tractor and implement.
- Stand clear of machine while in operation or when it is being raised or lowered.

FAILURE TO FOLLOW THESE INSTRUCTIONS COULD RESULT IN SERIOUS INJURY OR DEATH.

MS - 502 - A

**⚠ WARNING ⚠**

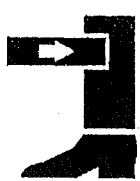

**CRUSHING HAZARD**

Stay clear of area. Failure to follow these instructions could lead to serious injury.

MS - 502 - A (Early Production)

# SAFETY DECAL PLACEMENT ILLUSTRATION

(DECALS SHOWN ON PAGE 6)

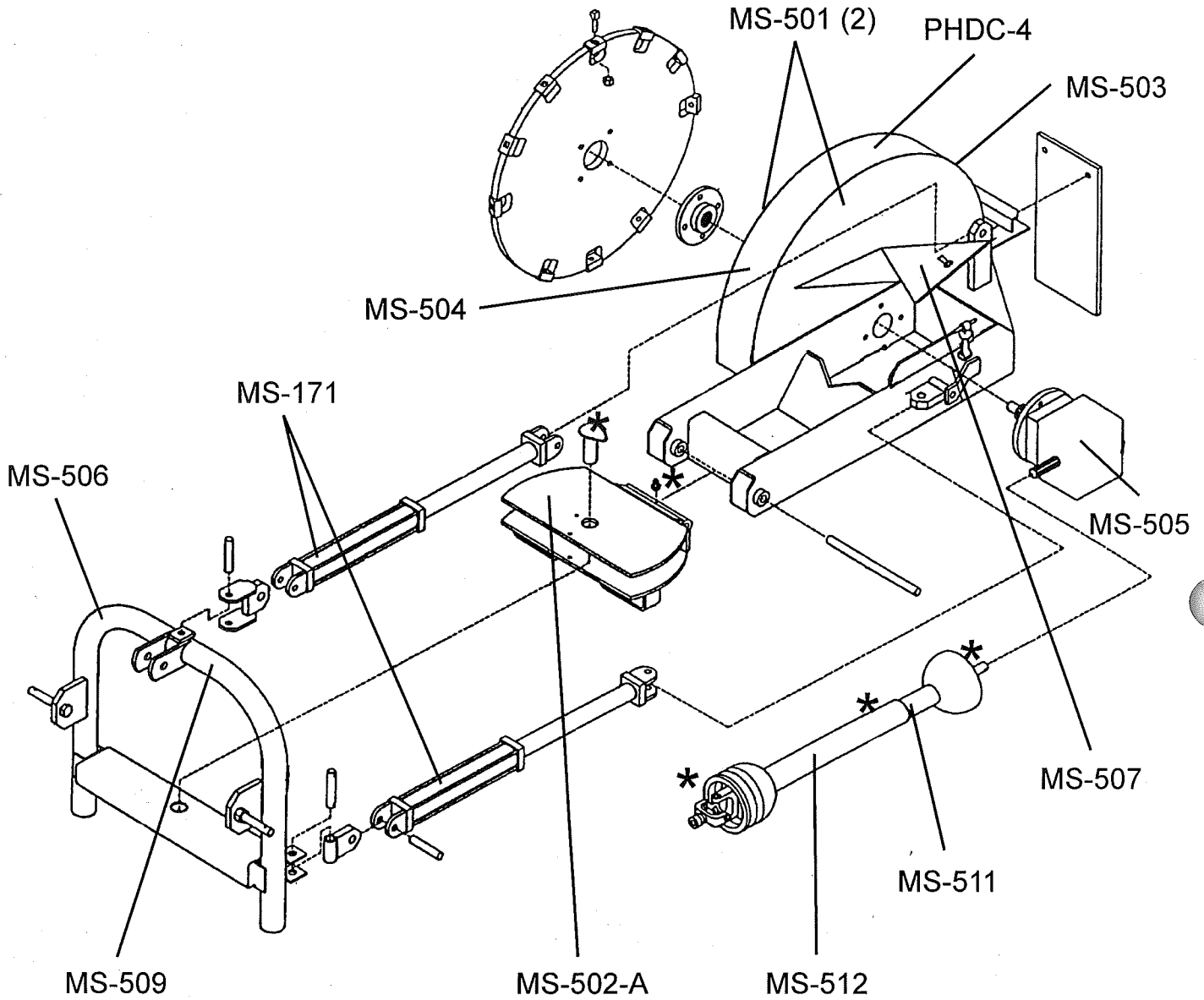

\* (5) Lubrication Points (see page 9)

# BEFORE OPERATING THE STUMPBUSTER™

## Before you Operate:

### (OWNER'S RESPONSIBILITY)

- Review and follow all safety rules and safety decal instructions on pages 3 through 7.
- Check that all safety decals are installed and in good condition. Replace if damaged.
- Check to make sure all shields and guards are properly installed and in good condition.
- Check that all hardware and cotter pins are properly installed and secured.
- Check that equipment is properly and securely attached to tractor.
- Inspect area and remove stones, branches or other hard objects that might be thrown, causing injury or damage.

### WARNING

- Do not allow bystanders in the area when operating, attaching, removing, assembling, or servicing equipment.
- Keep bystanders at least 100 feet away from equipment.
- Do not put stump cutter into service unless all shields and guards are in place and in good condition. Replace if damaged.
- Make sure that all operating and service personnel know that if hydraulic fluid penetrates skin, it must be surgically removed as soon as possible by a doctor familiar with this form of injury or gangrene, serious injury, or death will result. CONTACT A PHYSICIAN IMMEDIATELY IF FLUID ENTERS SKIN OR EYES. DO NOT DELAY.
- Keep hands and body away from pressurized lines. Use paper or cardboard, not hands or other body parts to check for leaks. Wear safety goggles. Hydraulic fluid under pressure can easily penetrate skin and will cause serious injury or death.
- Make sure spring-activated locking pin or collar slides freely and is seated firmly in tractor PTO spline groove, on the SC-50.
- Do not raise stump cutter higher than 24" from ground level.

- Check all lubrication points and grease as instructed in Lubrication Information.
- Make sure driveline spring -activated locking pin or collar slides freely and is seated firmly in tractor PTO spline groove and in gearbox spline groove.
- On SC-50-H, make sure the skid loader bracket is secured by locking levers in the down position.
- Raise the hydraulic stump cutter 24" from the ground to the bottom of cutting wheel. Place lift limit chain through the skid steers safety loop. Connect both ends of the chain with bolts, washers, and hex nuts provided.
- Do not allow riders.
- Consult local utilities before digging. Know location of and avoid contacting all underground cables, pipelines, overhead wires, and other hazards in digging area.
- Check condition of stump grinder teeth before operation.

### WARNING

- Know your controls and how to stop engine and attachment quickly in an emergency.
- Operators must be instructed in and be capable of the safe operation of the equipment, its attachments, and all controls. Do not allow anyone to operate this equipment without proper instructions, and familiarize all operators with the operators manual.
- Never allow children or untrained persons to operate equipment.
- Always wear relatively tight and belted clothing to avoid entanglement in moving parts. Wear sturdy, rough-soled work shoes and protective equipment for eyes, hair, hands, hearing, and head.
- Make sure attachment is properly secured, adjusted, and in good operating condition.

**NOTE:** For operation of this stump cutter, references to right, left, forward, and rearward directions are determined from the operator's position in the tractor seat.



# MAINTENANCE OF THE STUMPBUSTER™

## (BEFORE AND DURING OPERATION)

### ! IMPORTANT !

#### STUMP CUTTER UNIT LUBRICATION

- Do not let excess grease collect on or around parts, particularly when operating in sandy areas.
- Use a lithium grease of #2 consistency for all locations unless otherwise noted.

**NOTE:** Be sure to clean fittings thoroughly before attaching grease gun. One good pump of most guns is sufficient when the lubrication schedule is followed.

- Grease stump cutter swivel points every 8 hours.

(See Page 7)  
5 Locations to Grease  
are Marked, \*

#### GEARBOX LUBRICATION

- Gearbox does not contain oil. Fill before operating. Failure to do so will void the 1-year warranty.

Fill gearbox with 6 pints of SAE 90 oil.

Grease both fittings on the swivel assembly shown on page 7.

##### SC-50 Only

Grease U-joints on end of driveline as shown.

##### SC-50 Only

Grease slip joint on driveline.

**NOTE:** Check gearbox oil level daily after initial start up.

- For gearbox, use a high quality gear oil with a viscosity index of 80W or 90W and an API service rating of GL-4 or -5 in gearboxes.
- Fill gearbox until oil runs out the side plug on gearbox. Check gearbox daily for evidence of leakage, and contact your dealer if leakage occurs.

#### REPLACE STUMP CUTTER CARBIDE TEETH

**NOTE:** Replace teeth whenever they become damaged, broken, or excessively worn. Excessively worn cutting edges greatly decrease cutting efficiency. Teeth are not a "warranty" part.

##### IMPORTANT

- Never operate the stump cutter with missing teeth.

Remove hex nut from tooth.

Remove tooth.

Insert new tooth and secure with hex nut.

Torque nut to 170 lbs.-ft.

#### DRIVELINE LUBRICATION (SC-50 Only)

- Lubricate the driveline slip joint every eight operating hours. Failure to maintain proper lubrication could result in damage to the U-joints, gearbox, and driveline. Failure to properly maintain may result in loss of warranty consideration. (There are 3 points, shown on page 7.)
- Lower stump cutter to ground, disconnect driveline from tractor PTO shaft, and slide halves apart but do not disconnect from each other.
- Apply a bead of grease completely around male half where it meets female half. Slide drive halves over each other several times to distribute grease.

#### Install 3-Point Pins (SC-50)

**NOTE:** Stump cutter includes Category 1 and Category 2 hitch pins. Install hitch pins as instructed below.

##### Category 1 Hitch Pin

- Install hitch pin on the **inside** of 3-point attachment bracket as shown in Figure 3. Secure with lock washer and hex nut.

##### Category 2 Hitch Pin

- Install hitch pin on the **outside** of 3-point attachment bracket as shown in Figure 4. Secure with lock washer and hex nut.

# OPERATING THE STUMPBUSTER™

## ATTACHING SC-50 STUMPBUSTER™ TO A TRACTOR 3-POINT

- **Raise top cylinder completely BEFORE raising 3-point lower lift arms to avoid damaging the PTO shaft!**
- Make sure the Jack Stand Leg and (2) Stabilizers are securely on the ground.
- Attach stump cutter hitch pins to the tractor's lower lift arms and secure. (Category I & II are provided.)
- Attach tractor top link to Third Arm Ear and secure by installing the tractor top link pin.
- Connect the PTO shaft to the tractor's power take-off.
- Slide the slip collar back or push slip pin in to make a secure connection. Slip Collar or slip pin should snap back into its original position if connection is secure.
- Adjust the 3-point anti-sway devices to prevent the stump cutter from side-to-side movement during transport.
- Adjust the tractor's drawbar so it will not interfere with the stump cutter or the PTO shaft.
- Adjust the 4 quick couplers to the tractor's hydraulic power source. (Must obtain locally.)
- Take the Jack Stand Leg out of the storage position and pin securely.
- **RAISE TOP CYLINDER**, then raise the 3-point lower lift arms.

---

## ATTACHING SC-50-H HYDRAULIC STUMPBUSTER™ TO A SKID STEER LOADER

- Make sure jack stand leg and stabilizers are securely on the ground.
- Attach the stump cutter to the skid loader with the Fast Tach Bracket by mounting the plate on the boom and moving the boom levers into the down position. Check that levers are locked and secure.
- Locate the hose connected to the valve port marked "P". This is the pressure hose. Attach quick coupler to its end, then connect to the skid loader's hydraulic pressure source.
- Locate the hose connected to the valve port marked "R". This is the hose for the oil to return to the skid loader. Connect your quick coupler to its end and then connect to the skid loader return outlet.
- Place the toggle switch in your desired position on the frame of the skid loader. Drill a ½ inch hole and mount the toggle switch with the nut provided (on the toggle switch).
- Connect the black wires of the Harness provided to the "ground" feature on the skid loader.
- Connect the red wires to the "power" (12 volt) feature of the skid loader.
- Take jack stand leg out of the park position and secure with the pin. Attach the lift limit chain to the skid loader's safety loop. Raise the skid loader booms.

# INSTRUCTIONS ON OPERATING THE STUMP CUTTER TO ACHIEVE THE BEST RESULTS

## FOR THE SC-50 STUMPBUSTER™

- Top Cylinder must be completely raised to avoid damage to the PTO Shaft BEFORE raising the 3-Point lower lift arms.
- Power for operating the stump cutter is supplied by the tractor power take-off. Know how to stop the tractor and the stump cutter quickly in case of an emergency.
- Position the stump cutter above the stump to be removed. Engage the PTO at low engine rpm to avoid excess stress on the gearbox and PTO shaft. Once the PTO shaft is engaged, increase PTO speed to 540 rpm and maintain during the cutting.
- Lower the 3-point arms until the stabilizer pads are securely on the ground.
- Engage the top cylinder to lower the wheel to the desired depth on the stump.
- Start the wheel on the left edge of the stump and slowly engage the side cylinder to begin cutting.
- Once each pass is completed, activate the side cylinder to the left, lower the top cylinder to remove more wood, then activate the side cylinder to the right. If the stump is large, reposition the tractor and repeat the process.
- When finished removing stump, disengage PTO Shaft, raise the Top Cylinder, then raise the stump cutter off the ground by raising the 3-point lower lift arms.
- Do not raise the stump cutter more than 24" above ground level.

---

## FOR THE SC-50-H HYDRAULIC STUMPBUSTER™

- Power for operating the stump cutter is supplied by the skid loader's hydraulic pressure. Know how to stop the skid loader and stump cutter quickly in case of an emergency.
- Engage the hydraulic pressure. Increase rpm to 795 and maintain during the cutting.
- Lower the skid loader booms onto the stump until wheel is at desired cutting depth.
- Engage wheel motion and position on the right side edge of the stump. Slowly activate the side cylinder to begin cutting.
- With each pass complete, activate the side cylinder to the right, lower the stump cutter to desired depth to remove more wood, then activate the side cylinder to the left. If the stump is large, reposition the skid loader and repeat the process.
- Once stump is removed, disengage the skid loader hydraulics. Raise the stump cutter until the stabilizer pads are off the ground.
- Do not raise the stump cutter more than 24" above ground level.
- Raise stump cutter 24" from the ground to the bottom of the cutting wheel. Place lift limit chain through the skid steer's safety loop. Connect both ends of the chain with bolts, washers, and hex nuts provided.

# ADJUSTING SLIP CLUTCH ON SC-50 STUMPBUSTER™

The slip clutch is designed to slip so that the gear-box and driveline are protected if the cutter strikes an obstruction.

A new slip clutch or one that has been in storage over the winter may seize. Before operating the grinder, make sure it will slip by performing the following operation:

Turn off tractor engine and remove key.

Remove driveline from tractor PTO.

Loosen eight cap screws (A) to remove all tension from pressure plate (B).

Hold clutch support (C) solid and turn shaft to make sure clutch slips.

If clutch does not slip freely, disassemble and clean the inner clutch plate faces (D), flange yoke (E), and clutch support (C).

Reassemble clutch.

Tighten springs (F) until they are compressed to the 1.31 inches.

If a clutch continues to slip when the springs are compressed to the 1.31 inch dimension, check lining ring (G) for excessive wear. Lining rings are 1/8" when new. Replace rings after 1/16" wear. Minimum lining ring thickness is 1/16".

**NOTE:** The slip clutch is not a "warranty" part.

Nut  
Clutch Spring  
Flanged Yoke  
Lining Ring  
Clutch Support  
Inner Clutch Plate  
Pressure Plate  
Cap Screw (8)

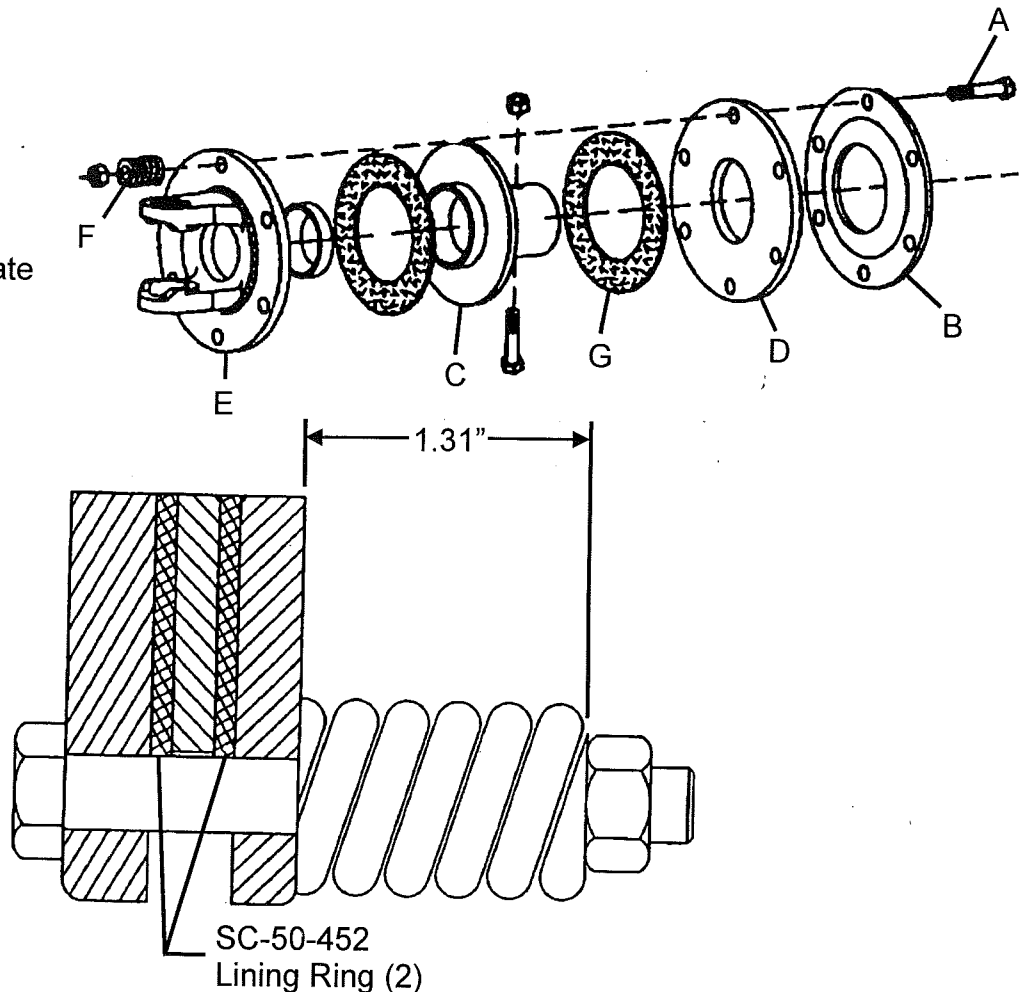

# STORING THE STUMP CUTTER:

## FOR THE SC-50 STUMPBUSTER™

- Raise stump cutter with 3-point lower lift arms.
- Remove lynch pin from jack stand.
- Lower jack stand and align top hole in jack stand leg with hole in jack stand support bracket.
- Insert lynch pin to secure jack stand into position.
- Lower stump cutter with 3-point lower lift arms to the ground and top cylinder until the jack stand and (2) stabilizers are securely on the ground.

---

## FOR THE SC-50-H HYDRAULIC STUMPBUSTER™

- Raise stump cutter with skid loader booms.
- Remove lynch pin from jack stand.
- Lower jack stand and align top hole in jack stand leg with hole in jack stand support bracket.
- Insert lynch pin to secure jack stand into position.
- Lower stump cutter to ground until jack stand and stabilizers (2) are securely on the ground.

# SC-50 3-POINT STUMPBUSTER™ PARTS BREAKDOWN

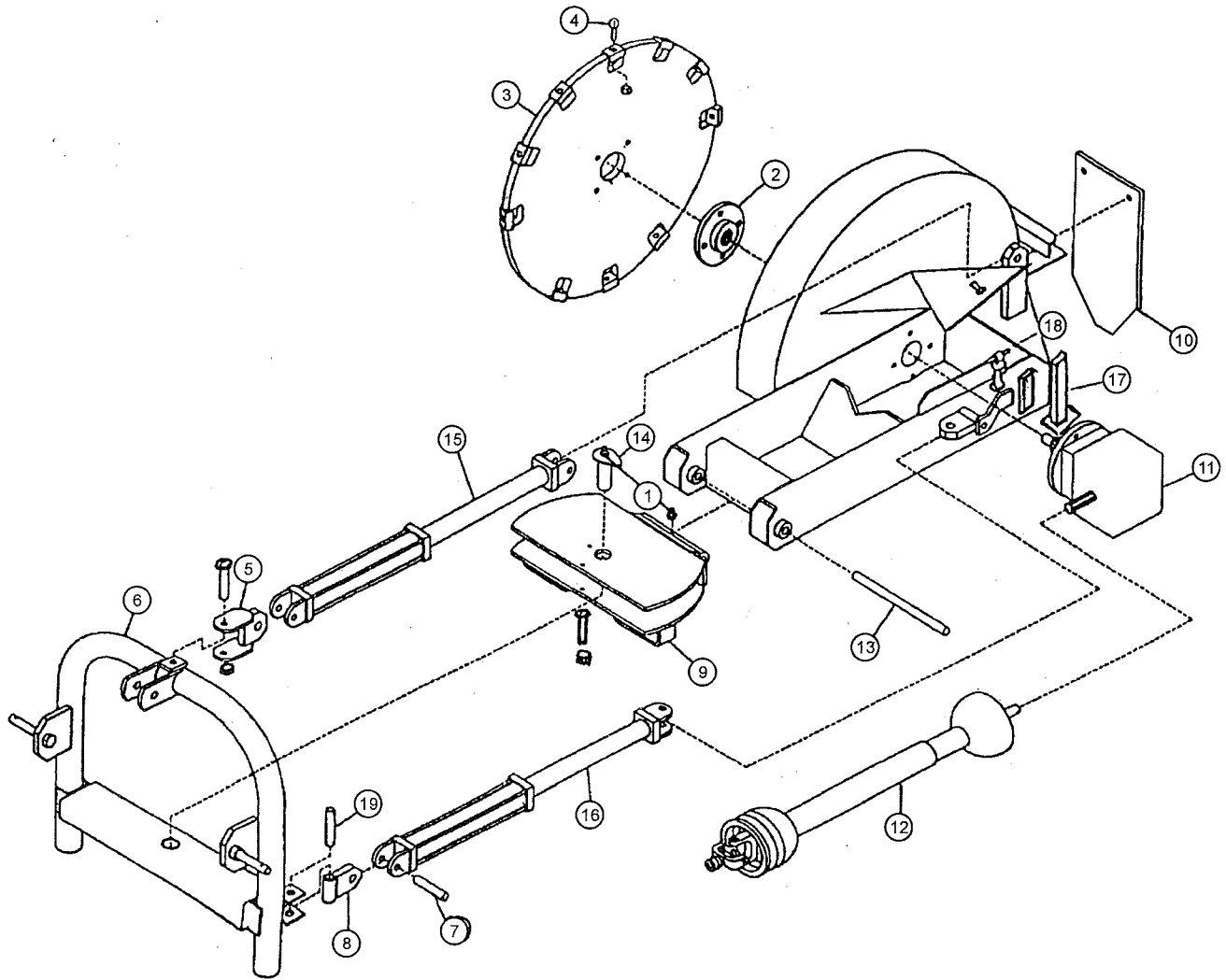

Pos.	Part Number	Description
1.	SC-50-73	Grease Zerk (2)
2.	SC-50-53	Gearbox Hub to Wheel Attach
	SC-50-54	Hub to Wheel Bolt & Locknut
3.	SC-50-91A	Cutting Wheel less Teeth.
4.	SC-50-15	Carbide Teeth
5.	SC-50-62D	Top Cylinder Swivel Attach.
	SC-50-81	Top Cylinder / Swivel Bolt
	SC-50-82	Top Cylinder / Swivel Nut
6.	SC-50-8	3-Pt. Attachment Bracket
	SC-50-83	Tractor Attach Pin (Cat. I)
	C-50-83A	Tractor Attach Pin (Cat. II)
7.	SC-50-71	Side Cylinder / Swivel Pin Comp.
8.	SC-50-61-E	Side Cylinder / Swivel Attach
9.	SC-50-70	Swivel Assembly
	SC-50-74	Swivel Bolt & Locknut
10.	SC-50-3	Safety Shield w/ Bolts

Pos.	Part Number	Description
10.	SC-50-32	Safety Shield Bolt (1/4 x 1)
	SC-50-33	Safety Shield Nut (1/4)
	SC-50-34	Safety Shield Washer (1/4)
11.	SC-50-5	Gearbox w/ Bolts
	SC-50-52	Gearbox Bolt & Locknut
12.	SC-50-4	PTO w/ Slip Clutch
13.	SC-50-71	Swivel Assy. Pin Complete
14.	SC-50-72	Swivel / 3-Pt. Pin Complete
15.	SC-50-62	Top Cylinder Complete
	SC-50-621	Top Cylinder Pin w/ Clip
16.	SC-50-61	Side Cylinder Complete
	SC-50-613	Side Cylinder Pin w/ Clips
17.	SC-50-27	Jack Stand Leg w/ Lynch Pin
18.	SC-50-3A3	Rubber Strap Assy.
19.	SC-50-75	Swivel Ear Pin

# SC-50-H HYDRAULIC STUMPBUSTER™ PARTS BREAKDOWN

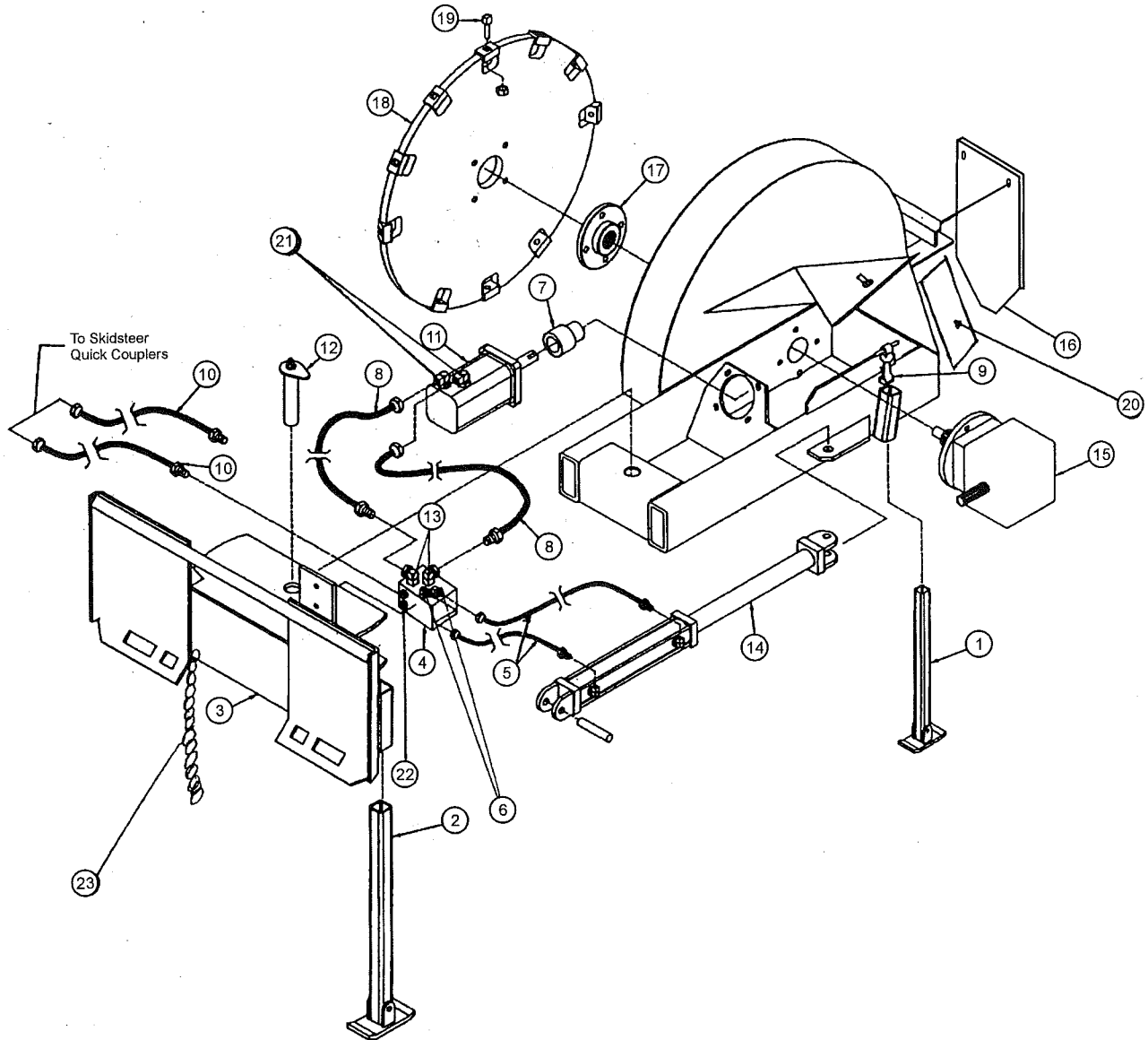

Pos.	Part Number	Description
1.	SC-50-27	Jack Stand Leg
2.	SC-50-H37	Stabilizer Leg (Cutter)
3.	SC-50-H3	Skid Loader Bracket (Cutter)
4.	SC-50-H6	Valve Complete
5.	SC-50-H41	Cylinder Hose
6.	SC-50-131	9/16" Oring x 90 Elbow
7.	SC-50-H7	Gearbox to Motor Coupler
8.	SC-50-H64	Pressure Hose (3/4" x 21")
9.	SC-50-3A3	Rubber Strap
10.	SC-50-H65	Pressure Hose (3/4" x 36")
11.	SC-50-H5	Hydraulic Motor Complete
12.	SC-50-H31	Swivel Plate Pin

Pos.	Part Number	Description
13.	SC-50-H52	Valve Fitting
14.	SC-50-61	Side Cylinder Complete
15.	SC-50-5	Gearbox Complete
16.	SC-50-3	Safety Shield with Bolts
17.	SC-50-53	Gearbox Hub to Wheel Atchmnt.
18.	SC-50-9	Cutting Wheel with Teeth
	SC-50-91A	Cutting Wheel less Teeth
19.	SC-50-15	Carbide Tooth
20.	SC-50-40	Debris Guard Complete
21.	SC-50-H54	Motor Fitting
22.	SC-50-H53	Valve Fitting (1" x 3/4")
23.	SC-50-H4	Lift Limit Chain

# SC-50-5 GEARBOX PARTS BREAKDOWN

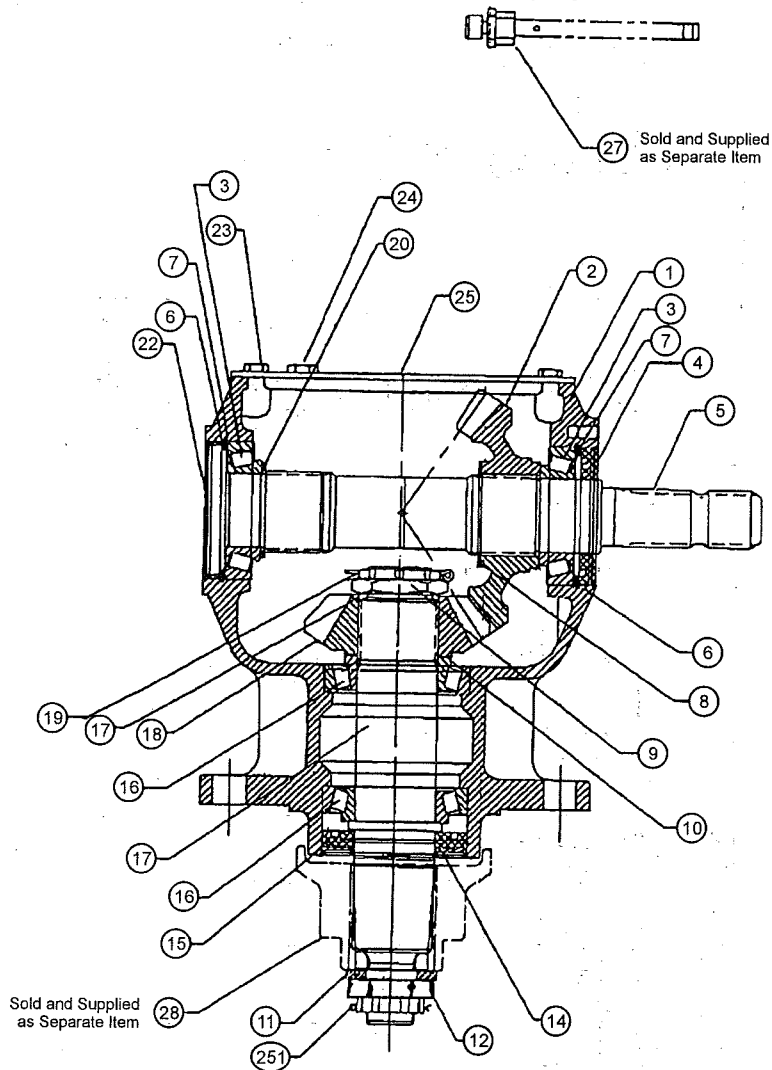

Pos.	Part Number	Description
1.	SC-50-5B	Casting
2.	SC-50-5C	Gear Crown
3.	SC-50-5D	Bearing
4.	SC-50-5E	Oil Seal
5.	SC-50-5F	Input Shaft 1-3/8"
6.	SC-50-5G	Snap Ring
7.	SC-50-5H	Shim
8.	SC-50-5J	Snap Ring
9.	SC-50-5K	Nut
10.	SC-50-5L	Shim
11.	SC-50-5M	Bolt Washer
12.	SC-50-5N	Castle Nut
13.	SC-50-5P	Shim
14.	SC-50-5Q	Protective Washer
15.	SC-50-5R	Oil Seal

Pos.	Part Number	Description
16.	SC-50-5T	Bearing
17.	SC-50-5U	Shaft Output
18.	SC-50-5V	Pinion
19.	SC-50-5W	Cotter Pin
20.	SC-50-5X	Shim
21.	SC-50-5Y	Plug 3/8" Gas
22.	SC-50-5Z	Cap
23.	SC-50-5B1	Bolt
24.	SC-50-5B2	1/2" Gas Solid Plug
25.	SC-50-5B3	Cover
26.	SC-50-5B4	Plate Gear Boxplate
27.	SC-50-5B5	Oil Level Plug
28.	SC-50-53A	Hub
29.	SC-50-5B7	Cotter Pin



# SC-50 ONLY: SC-50-4 PTO SHAFT PARTS BREAKDOWN

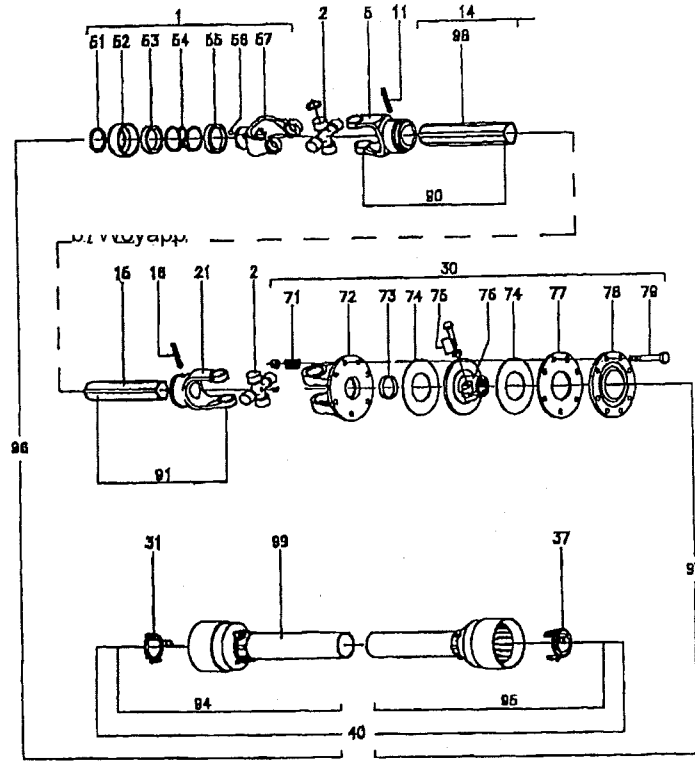

Pos.	Part Number	Description	Qty.
1.	SC-50-41	Complete collar yoke	1
2.	SC-50-42	Cross journal set	2
5.	SC-50-43	Outer yoke	1
11.	SC-50-44	Roll pin for outer tube	1
14.	SC-50-45	Outer tube	1
15.	SC-50-46	Inner tube	1
16.	SC-50-47	Roll pin for inner tube	1
21.	SC-50-48	Inner yoke	1
30.	SC-50-49	Complete disc clutch	1
31.	SC-50-411	Guard retaining collar for outer tube	1
37.	SC-50-421	Guard retaining collar for inner tube	1
40.	SC-50-431	Complete guard	1
51.	SC-50-441	Outer circlip	1
52.	SC-50-451	Sliding sleeve collar	1
53.	SC-50-461	Ball hold-up ring	1
54.	SC-50-471	Spring	1
55.	SC-50-481	Fixed sleeve	1
56.	SC-50-491	Ball 1/2"	3
57.	SC-50-412	Yoke	1
71.	SC-50-422	Spring	8
72.	SC-50-432	Flanged yoke	1
73.	SC-50-442	Bush	1
74.	SC-50-452	Lining ring	2
75.	SC-50-462	Bolt	2
76.	SC-50-472	Clutch support	1
77.	SC-50-482	Inner plate	1
78.	SC-50-492	Pressure plate	1
79.	SC-50-413	Bolt	8
90.	SC-50-423	Female tube yoke with roll pin and label	1
91.	SC-50-443	Male tube yoke with roll pin	1
94.	SC-50-453	Half female guard	1
95.	SC-50-463	Half male guard	1
96.	SC-50-473	Half female shaft with guarding	1
97.	SC-50-483	Half male shaft with guarding	1
98.	SC-50-493	"DANGER" Label for outer tube	1
99.	SC-50-414	"DANGER" Label for guard tube	1



*Making hard work easy*

**Shaver Manufacturing Company**  
*Setting the standard in fencing and landscape equipment*

P.O. Box 358, Graettinger, IA 51342 • 712-859-3293 • FAX 712-859-3294

© December 2001