



Operators & Parts Manual



Hydraulic Post Driver

Models HD-8-S, HD-8-H-S,
HD-10-S, HD-10-H-S,
HD-12-H-S & SHD-10

Safety

Operation

Maintenance

Repair

Troubleshooting

Parts

HD8/10/12OPMAN (a) 5/18

Shaver Manufacturing Company
103 South Washington Avenue, Graettinger, Iowa 51342
Phone: (712) 859-3293 — Fax: (712) 859-3294 — www.shavermfg.com

Contents

Safety.....	3	Service Procedures.....	32
General.....	4	Dismounting Post Driver from Base Plate.....	32
Safety Alert Symbols.....	4	Post Driver Disassembly.....	33
Safety Icon Nomenclature.....	5	Seal Replacement.....	34
Safety Warnings.....	6	Spring Replacement.....	34
General Safety.....	6	Guide Block/Roller Replacement.....	35
Hazard Avoidance.....	6	Post Driver Reassembly.....	35
Hydraulic Hoses.....	7	Forward and Side Tire Cylinder Seal	
Introduction.....	8	Replacement.....	38
Product Information.....	8	Three-Point Hitch/Post Driver Assembly .	38
Specifications.....	8	Storage.....	39
Safety Sign Locations.....	9	Troubleshooting.....	40
Safety Signs.....	10	Service Parts.....	42
Assembly Procedure.....	11	Driver Assembly.....	42
Unpacking.....	11	HD-8/HD-10/SHD-10 Ram.....	42
Assembly - General.....	11	HD-12 Ram.....	44
Mounting Instructions.....	12	Driver Assembly- Springs.....	46
Front-Mounted.....	12	HD-8/HD-10 Springs.....	46
Front-Mounted Main Carriage Channel..	12	HD-12 Springs.....	47
Mounting Instructions.....	13	Driver Assembly- Road Locks & Cushion	49
Rear-Mounted (3-Point).....	13	HD-8/HD-10/HD-12 SHD-10 Road Lock	49
Self-Contained Mounting Package.....	14	HD-8/HD-10/ HD-12 SHD-10 Rubber	
Base Plate.....	15	Bumpers.....	49
Attaching Driver to Base Plate.....	15	Rubber Guard Assembly.....	50
Connection to Hydraulic Supply.....	16	Safety Arm Assembly.....	51
Hydraulic Valve & Hose Installation.....	17	Manual Base Plate Assembly.....	52
Single Lever Control Valve for Hydraulic		HD-8/HD-10 Manual Base Plate.....	52
Manual Plate.....	18	Hydraulic Base Plate Assembly.....	54
Triple Lever Control Valve for Hydraulic		HD-8/HD-10 Hydraulic Base Plate.....	54
Base Plate.....	19	HD-12/SHD-10 Hydraulic Base Plate ..	55
Rubber Debris Guard.....	20	Manual Base Plate Valve & Hose ASSY..	56
Safety Arm Assembly.....	20	Hydraulic Base Plate Valve & Hose ASSY	57
Document Storage Tube.....	22	3-Point Hitch Assembly.....	58
Attachment and Option Assembly.....	22	HD-8 3-Point Hitch CAT I.....	58
Steel Post Holders Accessory.....	22	HD-10/HD-12/SHD-10 3-Point Hitch CAT II	
Stabilizer Extension Accessory.....	22	58
Post Driver Operation.....	23	Stand Package.....	59
Operational Safety Tips.....	23	HD-10/HD-12/SHD-10 3-Point Hitch CAT	
Operating Instructions.....	24	III.....	59
3-Point Hitch Mounting.....	24	Skid Loader Mounting Assembly.....	60
Self-Contained Mounting.....	25	Hydraulic Control Valves.....	61
Preparing to Drive a Post.....	25	Single Control Lever Valve.....	61
Driving a Post.....	26	Multiple Control Lever Valves.....	61
Dismounting Post Driver.....	30	Self-Contained Hydraulics.....	62
		Self-Contained Mounting Package.....	62
		Mounting Package less Bracket.....	62

Pump/ Motor Kit.....	63
Driver Cylinder Assembly	64
Attachments-Pilot Augers.....	65
Auger Assembly 4" & 6"	65
6" Auger Fish Tail & Tooth Assembly..	66
Motor & Hose Assembly	67
Motor Mount Plate Assembly	67
Attachments-Concrete Breakers	68
Attachments-Steel Post Holders.....	69
Attachments-Stabilizer Extensions	69
Replacement Decals	70
Limited Warranty	71
Warranty Card	73

Safety

Most work-related accidents are caused by failure to observe basic safety rules or precautions. An accident can often be avoided by recognizing potentially hazardous situations before an accident occurs. As you assemble and operate the Shaver Post Driver, you must be alert to potential hazards. You should also have the necessary training, skills, and tools to perform this assembly procedure.

Improper operation and maintenance of this implement could result in a dangerous situation that could cause injury or death.

Do not assemble, operate, or maintain the Shaver Post Driver until you read and understand the information contained in this manual.



Safety precautions and warnings are provided in this manual and on the product. If these hazard warnings are not heeded, bodily injury or death could occur to you or to other persons.

Safety

General

Safety of the operator and bystanders is one of the main concerns in designing and developing a new piece of equipment. Designers and manufacturers build in as many safety features as possible. However, every year many accidents occur, which could have been avoided by a few seconds of thought and a more careful approach to handling the equipment.

Most work-related accidents are caused by failure to observe basic safety rules or precautions, neglect, or carelessness. An accident can often be avoided by recognizing potentially hazardous situations before an accident occurs. As you operate, or maintain the unit, you must be alert to potential hazards. You should also have the necessary training, skills, and tools to perform any assembly or maintenance procedures.

Only properly trained people should operate this machine. Improper operation and maintenance of this unit could result in a dangerous situation that could cause injury or death.

If you have any questions not answered in this manual or require additional copies or the manual is damaged, please contact your dealer or

Shaver Manufacturing Company
103 South Washington Avenue
P.O. Box 358
Graettinger, Iowa
51342

Phone: (712) 859-3293
Fax: (712) 859-3294
Website: www.shavermfg.com
E-mail: sales@shavermfg.com

WARNING



Do not use the unit until you read and understand the information contained in this manual.



Safety precautions and warnings are provided in this manual and on the unit. If these warning instructions are not followed, bodily injury or death could occur to you or to other persons.

Shaver Manufacturing Company cannot anticipate every possible circumstance that might involve a potential hazard. The warnings in this manual and on the unit are, therefore, not all-inclusive. If a method of installation or operation not specifically recommended by us is used, you must satisfy yourself that it is safe for you and for others. You should also ensure that the unit will not be damaged or be made unsafe by the methods that you choose.

The information, specifications, and illustrations in this manual are based on the information that was

available at the time this material was written and can change at any time without notice.

Safety Alert Symbols



This is the safety alert symbol. It is used to alert you to potential personal injury hazards. Obey all safety messages that follow this symbol to avoid possible injury or death.

This manual contains DANGERS, SAFETY INSTRUCTIONS, CAUTIONS, IMPORTANT NOTICES, and NOTES which must be followed to prevent the possibility of improper service, damage to the equipment, personal injury, or death. The following key words call the readers' attention to potential hazards.

Hazards are identified by the "Safety Alert Symbol" and followed by a signal word such as "DANGER", "WARNING", or "CAUTION".

DANGER

Indicates an imminently hazardous situation which, if not avoided, will result in death or serious injury. This signal word is limited to the most extreme situations.

WARNING

Indicates a potentially hazardous situation which, if not avoided, could result in death or serious injury.

CAUTION

Indicates a potentially hazardous situation which, if not avoided, may result in minor or moderate injury.

NOTICE























Indicates that equipment or property damage can result if instructions are not followed.

SAFETY INSTRUCTIONS

Safety instructions (or equivalent) signs indicate specific safety-related instructions or procedures.

Note: Contains additional information important to a procedure.

Safety Icon Nomenclature

	Read the manual
	Eye protection
	Foot protection
	Hand protection
	Hearing protection
	Inspect equipment
	Two-person operation
	Warning decal alert
	Bending hazard (hydraulic hose)
	Crushing hazard
	Crushing hazard (hand)
	Do not weld
	Electrocution hazard
	Explosion hazard
	High-pressure fluid hazard
	Impact hazard (hydraulic hose)
	Pressurized fluid
	Projectile hazard (body)
	Protective guards
	Safety alert symbol
	Slipping hazard
	Tripping hazard

Safety Warnings

General Safety

WARNING



To avoid personal injury or death, carefully read and understand all instructions before attempting to assemble and/or operate the Post Driver. Do not operate or work on equipment unless you read and understand the instructions and warnings in this and all other applicable manuals. Contact Shaver Manufacturing Company if any of the instructions provided are unclear or not understood. Proper care is your responsibility. Always follow all State and Federal health and safety laws and/or local regulations.



To help prevent personal injury, protective equipment must be worn during Post Driver assembly, operation, and maintenance. Personal protective equipment should include, but not be limited to, safety glasses, hearing protection, protective gloves, and steel toe footwear.

Personal injury can result from slips or falls. DO NOT leave tools or parts lying around the work area and clean up all spilled fluids immediately.

Hazard Avoidance

WARNING



Inspect this equipment before each use. Make sure all hardware is tight. Always replace worn or damaged parts before use.



To avoid personal injury or death, do not operate the Post Driver by yourself. Always have another person to control the machine or power source.

WARNING



Make sure all decals are securely attached to the Post Driver and are legible at all times. Always read and understand all decals before working on or operating the Post Driver.



Make sure all lock-pins and transport supports are secured in place before transporting or storing the Post Driver. While transporting, never ride on or permit others to ride on the Post Driver.



Improper operating procedures can create risk for the operator and bystanders. DO NOT use the Post Driver before making sure no one will be endangered.



To prevent personal injury or death, be aware of overhead electrical lines when operating the Post Driver. Electrocutation can occur even without direct contact with overhead power lines. Proceed cautiously around electrical lines and utility poles.



To prevent personal injury or death, always check for underground utilities, such as electrical wires, gas lines, and water pipes, before driving posts. Contact local utility companies for information on locating underground utilities.



To avoid serious injury or death, do not operate the Post Driver on steep slopes, as this can cause a roll over.



To avoid personal injury, always stand 45 degrees to the right of the post being driven while operating the Post Driver.

! WARNING



Potential pinch points. Keep hands clear of Post Driver while operating. Never place hand(s) on top of a post when inserting it into the Post Driver. Always close the safety arm before driving the post.



To avoid personal injury do not attempt to clean, adjust, or lubricate the Post Driver while it is in motion.



The rubber debris guard helps shield the operator from flying debris that may be generated during post driving. To avoid personal injury, make sure the rubber debris guard is securely attached to the Post Driver before driving posts.



To avoid personal injury or death, do not modify the Post Driver by welding, drilling, or grinding. Do not expose to extreme heat, such as from a torch.



The main carriage channel assembly is tall and heavy. To avoid tip over, resulting in serious injury or death, leave the overhead lifting device attached to the main carriage channel while assembling components.



To avoid serious injury or death, the safety arm must be installed after the Post Driver has been mounted on a machine, or the freestanding Post Driver has been secured to prevent tipping.

Hydraulic Hoses

! WARNING



Avoid damaging hydraulic hoses. Avoid sharp bends and kinks when routing hydraulic hoses. Using a bent or kinked hose will cause severe back-pressure. Sharp bends and kinks can internally damage the hose, leading to premature hose failure, resulting in personal injury.

! WARNING



Do not drop heavy objects on hoses. A sharp impact may cause internal damage to the hose. Applying pressure to a damaged hose may cause it to rupture, resulting in personal injury.



Mismatched couplings and hoses can cause the coupling to violently disconnect from the hose when placed under pressure; separating with sudden, extreme force which can result in property damage, personal injury, or death.

Replace a hose if any of the following conditions are present:

- End fittings that are damaged or leaking
- Outer coverings that are chafed or cut
- Wire shields that are exposed
- Outer coverings that are ballooning
- Flexible part of the hoses that are kinked
- End fittings that are displaced



Pressure can be trapped in a hydraulic system. Trapped pressure can cause sudden movement of an attachment. Use caution when disconnecting hydraulic lines or fittings. High-pressure oil that is released can cause a hose to move violently while spraying oil.



Escaping high-pressure fluid can penetrate the skin, causing serious injury. Relieve pressure before unhooking hoses. Check/tighten all connections before activating hydraulics. Never use your hand to check for leaks.

Introduction

The Shaver Manufacturing Company would like to congratulate you on your purchase of the Shaver Hydraulic Post Driver. You have selected the best Post Driver in its class. The clean design and uncomplicated working principle have made Shaver the largest selling Post Driver in the country.

The Shaver HD-8-S & HD-10-S (manual tilt adjustment) and HD-8-H-S, HD-10-H-S, SHD-10, & HD-12-H-S (hydraulic tilt adjustment) Hydraulic Post Drivers are a durable piece of equipment that, with regular maintenance, will provide many years of service.

This manual provides information regarding assembly, operation, and maintenance. It is important to read and become familiar with this manual before assembling or operating the Shaver Hydraulic Post Driver.

NOTE: For other valuable information on farm equipment operation and safety, refer to the following resources.

- **Farm Equipment Manufacturers Association (FEMA)**
<http://www.farmequip.org/home>
- **National Ag Safety Database**
<http://www.cdc.gov/nasd/>

Product Information

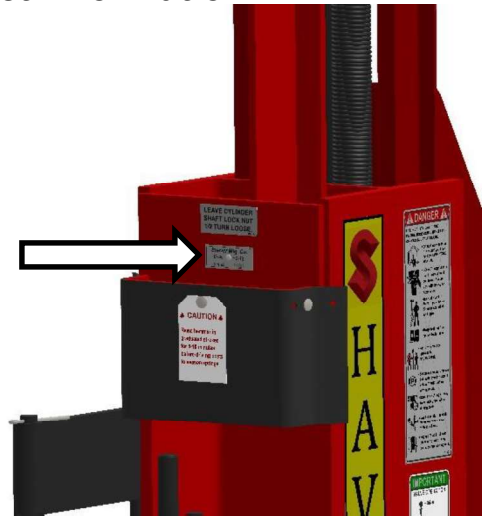

Record the Shaver product information here. The model number and serial number are found on the metal tag attached to the drive ram (see arrow above).

Model Number _____

Serial Number _____

Date Purchased _____

Dealer Name _____

Specifications

DESCRIPTION	HD-8-S & HD-8-H-S	HD-10-S & HD-10-H-S
Approximate Height ¹	88 in (223.5 cm) collapsed 133 in (337.8 cm) extended	100 in (254 cm) collapsed 148 in (376 cm) extended
Approximate Width ²	30 in (76.2 cm)	44 in (111.8 cm)
Approximate Depth ²	28 in (71.1 cm)	33 in (88.8 cm)
Shipping Weight	694 lbs. (315 kg) manual base 714 lbs. (324 kg) hydraulic base	694 lbs. (315 kg) manual base 714 lbs. (324 kg) hydraulic base
Effective Weight of Driving Ram	360 lbs. (163.3 kg) Spring Powered	725 lbs. (329 kg) Spring Powered
Impact (at full stroke)	30,000 lbs. (13,607.8 kg)	71,500 lbs. (32,432 kg)
Tilt Front/Back	15°/15°	15°/15°
Tilt Side/Side	15°/15°	15°/15°
Guide Blocks or Rollers	4 (2 per side)	4 (2 per side)
Mounting Options	Tractor (rear/front) and skid steer Three-Point Hitch Category I and II	Tractor (rear/front) and skid steer Three-Point Hitch Category II and III
Hydraulic Requirements	3 - 4 GPM at 1500 PSI (11.3-15.1 LPM at 10,342 kPa)	12 GPM at 1500 PSI (45 LPM at 10,342 kPa)
Post Size Maximums	Width 7-1/8 in (18.1 cm) Length 10 ft (3.0 m)	Width 8-3/4 in (22.2 cm) Length 10 ft (3.0 m)

¹ Driving ram and main carriage channel. Overall height will vary, depending on mounting position and tractor.

² With storage legs attached to three-point hitch weldment.

DESCRIPTION	SHD-10 Springless	HD-12-H-S
Approximate Height ¹	100 in (254 cm) collapsed 158 in (400 cm) extended	100 in (254 cm) collapsed 148 in (376 cm) extended
Approximate Width ²	44 in (111.8 cm)	44 in (111.8 cm)
Approximate Depth ²	33 in (88.8 cm)	38 in (96.5 cm)
Shipping Weight	1074 lbs. (487 kg)	975 lbs. (442 kg)
Effective Weight of Driving Ram	803 lbs. (364.3 kg)	1,100 lbs. (499 kg) Spring Powered
Impact (at full stroke)	95,000 lbs. (43,091 kg)	100,000 lbs. (45,359 kg)
Tilt Front/Back	20°/20°	20°/20°
Tilt Side/Side	25°/25°	25°/25°
Guide Blocks or Rollers	6 (3 per side)	6 (3 per side)
Mounting Options	Tractor (rear/front) and skid steer Three-Point Hitch Category II and III	Tractor (rear) and skid steer Category II and III
Hydraulic Requirements	12 GPM at 1500 PSI (45 LPM at 10,342 kPa)	15 GPM at 2000 PSI (45 LPM at 13,790 kPa)
Post Size Maximums	Width 8-3/4 in (22.2 cm) Length 10 ft (3.0 m)	Width 10-7/8 in (27.6 cm) Length 10 ft (3.0 m)

¹ Driving ram and main carriage channel. Overall height will vary, depending on mounting position and tractor.

² With storage legs attached to three-point hitch weldment.

Safety Sign Locations

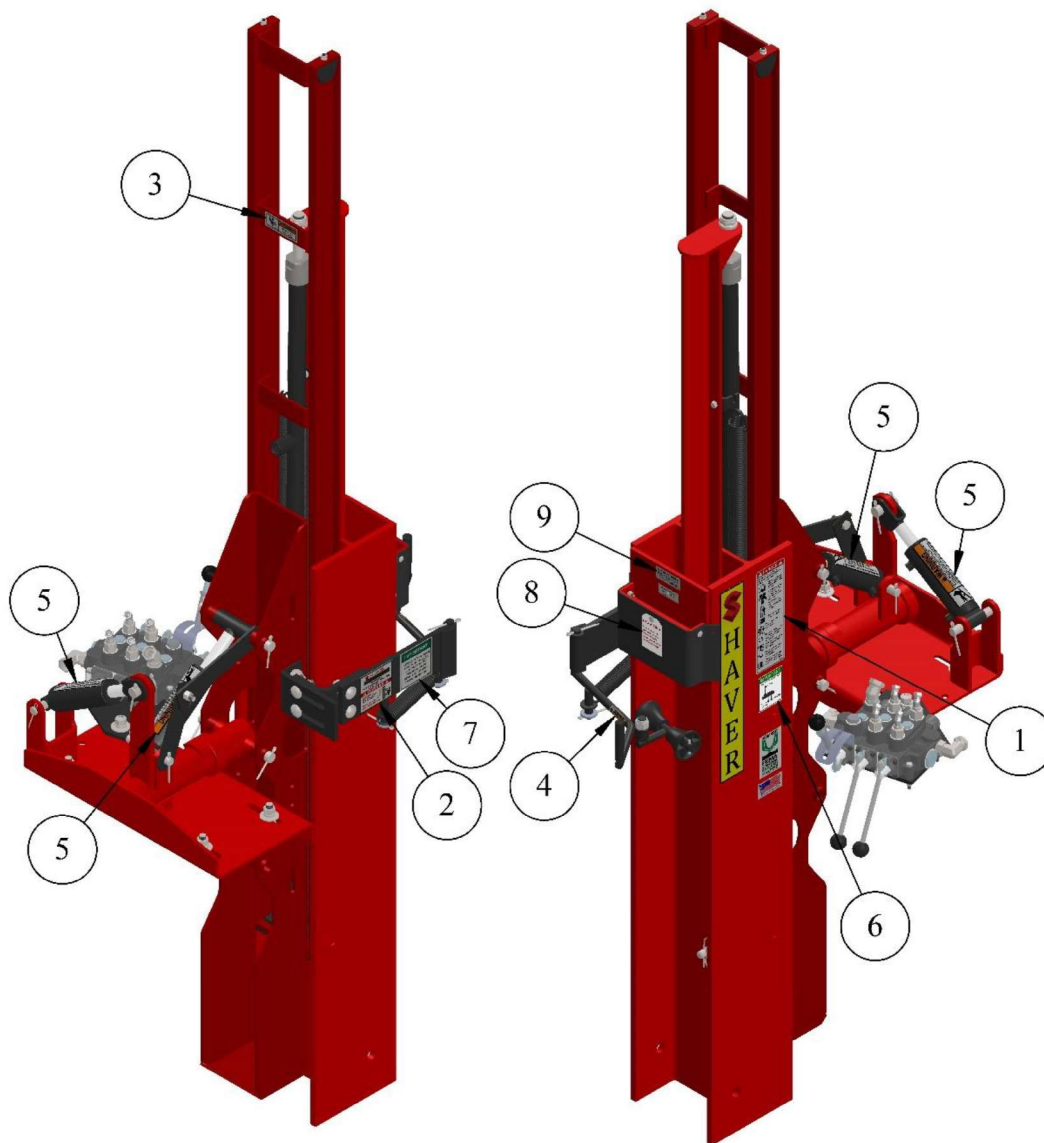

Driver Safety Signs and Informational Labels

Item	Part Number	Description
1	MS-183	Decal, Danger Instructions
2	MS-165	Decal, Danger Safety Arm Attachment
3	MS-163	Decal, Warning Pinch Point
4	MS-181	Decal, Warning Pinch Point
5	MS-171	Decal, Warning High Pressure Hydraulics
6	MS-106	Decal, Important Valve Instructions
7	MS-166	Decal, Important Leave Arm Open
8	SM-0011-ST	Tag, Caution Springs
9	MS-180	Decal, Cylinder Nut

Safety Signs

1. MS-183 – Decal, Danger Instructions

! DANGER !

FAILURE TO FOLLOW THESE INSTRUCTIONS COULD RESULT IN SERIOUS INJURY OR DEATH.

- DO NOT operate Post Driver until you have read the OPERATORS MANUAL.
- DO NOT set post with hand. Loss of hand can result. Secure post with Safety Arm Attachment.
- DO NOT stand in front of post driver. Some posts splinter on impact.
- Keep feet out from under driving ram.
- Post driver must be operated by ONE PERSON.
- Set brakes on unit or place automatic transmission of unit in "PARK" before driving posts.
- Stand at a 45° angle, away from driving ram, when driving posts.
- Use the safety arm at all times DO NOT set post with your hand.
- Engage Road Lock with pin when done driving posts or transporting unit.

MS-183

2. MS-165 – Decal, Danger Safety Arm Attachment

SHAYER

SM-0011-SAA
SAFETY ARM ATTACHMENT
U.S. PAT. 60-623325

! DANGER !

Do not set post with hand. Loss of hand can result.

Secure post with Safety Arm Attachment.

MS-165

3. MS-163 – Decal, Warning Pinch Point

! WARNING

PINCH AREA
Keep away

MS-163

4. MS-181 – Decal, Warning Pinch Point

! WARNING

PINCH POINT
Keep Away

MS-181

5. MS-171 – Warning High Pressure Hydraulics Decal

! WARNING

HIGH PRESSURE HYDRAULIC OIL LEAKS CAN PENETRATE SKIN

- CHECK FOR LEAKS WITH CARDBOARD; NEVER USE HAND.
- BEFORE LOOSENING FITTINGS: LOWER LOAD, RELEASE PRESSURE, AND BE SURE OIL IS COOL.
- CONSULT PHYSICIAN IMMEDIATELY IF SKIN PENETRATION OCCURS.

SKIN PENETRATION CAN RESULT IN SERIOUS INJURY AND GANGRENE.

MS-171

6. MS-106 – Decal, Important Valve Instructions

IMPORTANT

VALVE OPERATION

— Driver

Tilt — — Side Tilt
(In & Out)

MS-106

7. MS-166 – Decal, Important Leave Arm Open



8. SM-0011-ST –Tag, Caution Springs



9. MS-180 – Decal, Cylinder Nut



10. Decal, Warranty Void, Roadlock



Assembly Procedure

Unpacking

⚠ WARNING



Due to the size and weight of the Post Driver, two people are required for the assembly procedures.



The Post Driver is shipped in several sections: The Driving Ram Assembly, Base Plate Assembly, Hose and Valve Carton, Safety Arm Carton, and with the Hydraulic Post Driver (HD-8-H-S, HD-10-H-S, & HD-12-H-S) the Tilt Cylinder Carton.

⚠ WARNING



Before starting the unpacking procedure, make sure the overhead lifting device or material handling device (forklift) has adequate lifting capacity. Follow all safety recommendations when unpacking the Post Driver. Some components are heavy and can cause serious injury or death if not adequately supported during removal and assembly.

NOTE: For ease of assembly, unload the Post Driver components in the area where they will be assembled. Choose a large, hard surface area that can safely support the weight of the assembled Post Driver and is accessible by the machine it will be mounted on.

Assembly - General

NOTE: Refer to the Service Parts section of this manual for an illustration and description of all the parts.

The Main Carriage Channel has provisions for mounting the Base Plate (Manual or Hydraulic) in two positions.

- The **UPPER** Position (most common) - three-point hitch or tractor front mount (midsized tractors).
- The **LOWER** Position - for driving 10 ft. (3.0 m) tall posts only - three-point hitch or front tractor mount (smaller tractors).

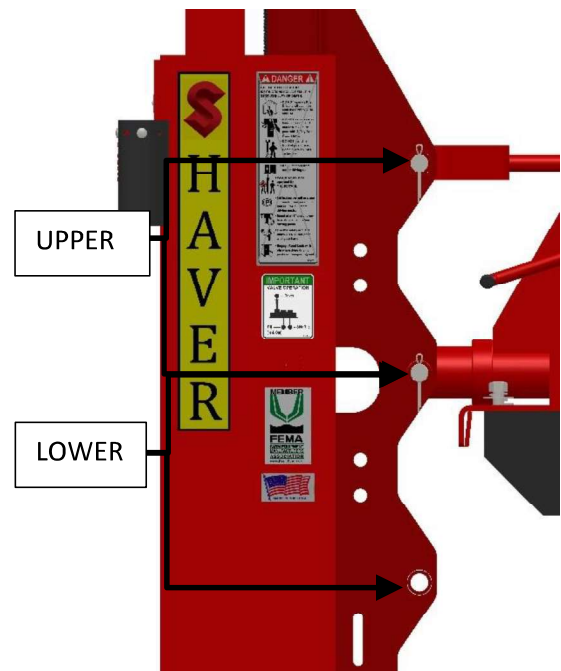

Driver and Base Plate on 3-point mount shown in **UPPER** Position.

The Post Driver assembly procedure consists of the following subsections:

1. Main Carriage Channel
2. Storage Legs
3. Base Plate
4. Hydraulic Valve
5. Safety Stop Adjustment
6. Rubber Debris Guard
7. Safety Arm
8. Manual Storage Tube

Mounting Instructions

Front-Mounted

1. Attach the Mounting Bracket(s) to the front of the tractor with the bolts provided. If no bolts are provided, use the bolts in the frame. Please refer to the individual instructions supplied with the tractor mounting kit.

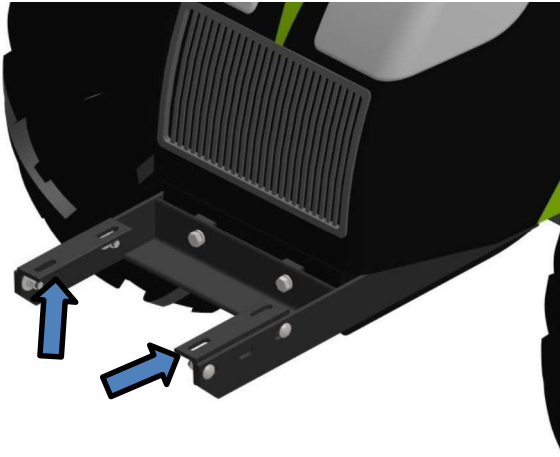

NOTE: Manual base plate installation is shown. Installation of Hydraulic base plate is similar.

2. Remove the carriage bolts, washers, and nuts from Manual base plate. Also remove the Base Plate Pins and the cotter pins at each end. Save the hardware and pins for the next step.

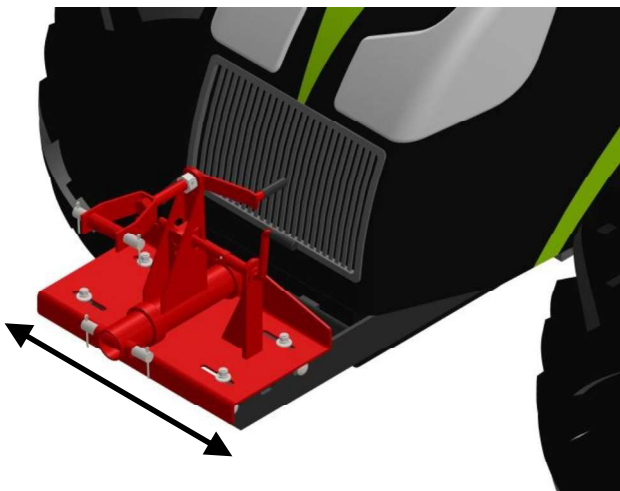

3. Install manual base plate on front mount adapter as shown. Install carriage bolts, washers, lock washers, and nuts removed in Step 1. Center the base plate on the three-point hitch and tighten the hardware securely.

Main Carriage Channel

4. Use a suitable overhead lifting device (arrow as shown) to raise (stand up) Main Carriage Channel. Position the Driver in front of the Base Plate as shown below.



! WARNING



The Main Carriage Channel assembly is tall and heavy. To avoid tip over, resulting in serious injury or death, leave the overhead lifting device attached to the Main Carriage Channel while assembling components.

- Align the bushings in the Driver with the bushings in the Base Plate (see arrows below). Install Pins and secure with the supplied cotter pins.

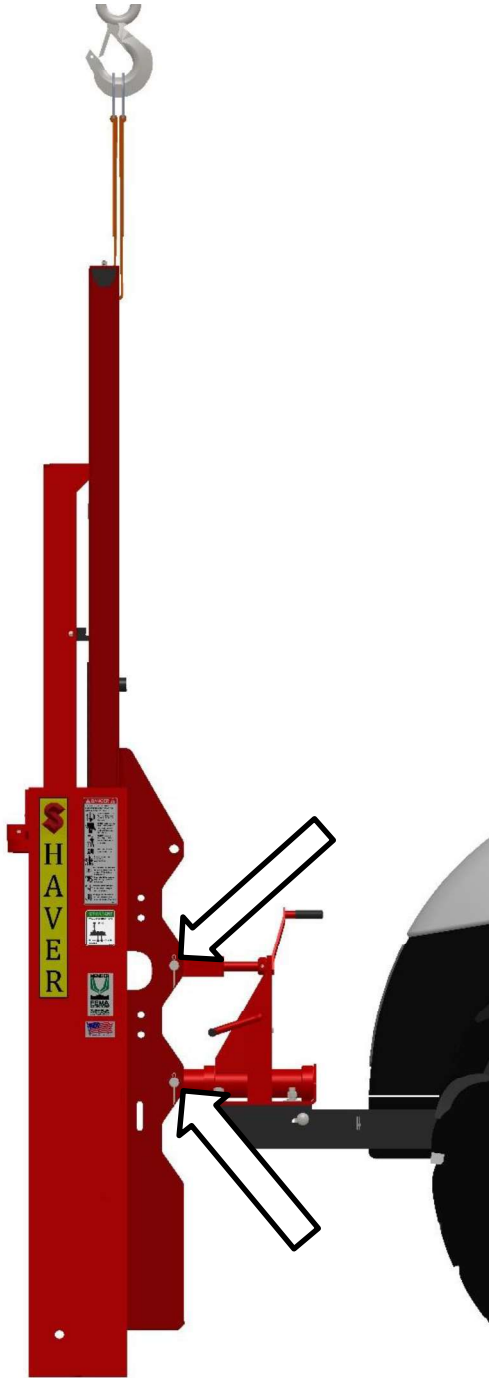

Front mounting of driver in **LOWER** position, HD-10 shown.

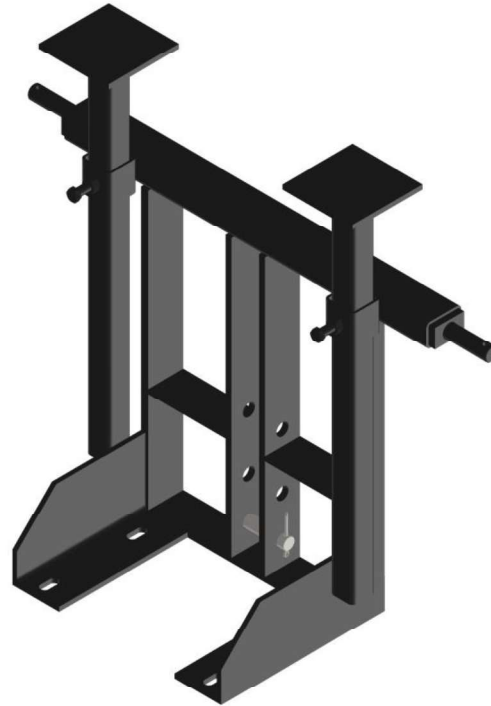

Storage leg heights on 3-point hitch mount.

Mounting Instructions

Rear-Mounted (3-Point Hitch)

- Place three-point hitch weldment upside down on the floor.
- Set storage leg height 'X' measured from three-point hitch weldment mounting angles to the storage leg baseplate, as shown. Tighten the storage leg lock bolts.
 - For **UPPER** Base Plate mounting position set 'X' at 45" (114.3 cm).
 - There is no useable dimension 'X' for storage legs when diver is in the **LOWER** Base Plate mounting position
- Turn over three-point hitch weldment and set it on storage leg base plates.

Self-Contained Mounting Package (Skid-Loader)

- Remove the plugs from the hydraulic reservoir, pump, and motor.
- Place Universal Mounting Bracket (item 1) on the floor. Install the Reservoir Bracket (item 3) on the outside of the mounting angles on

the Universal Mounting Bracket with two (2) each 1/2" bolt, lock washer and nut (items 9, 10, & 11). Attach the Pump/Motor/Reservoir (item 2) by lining up the slots in the Pump/Motor/Reservoir with slots in the Universal Mounting Bracket and the Reservoir Bracket, then secure four (4) each 3/8" bolt & lock nut and eight (8) flat washer (see below).

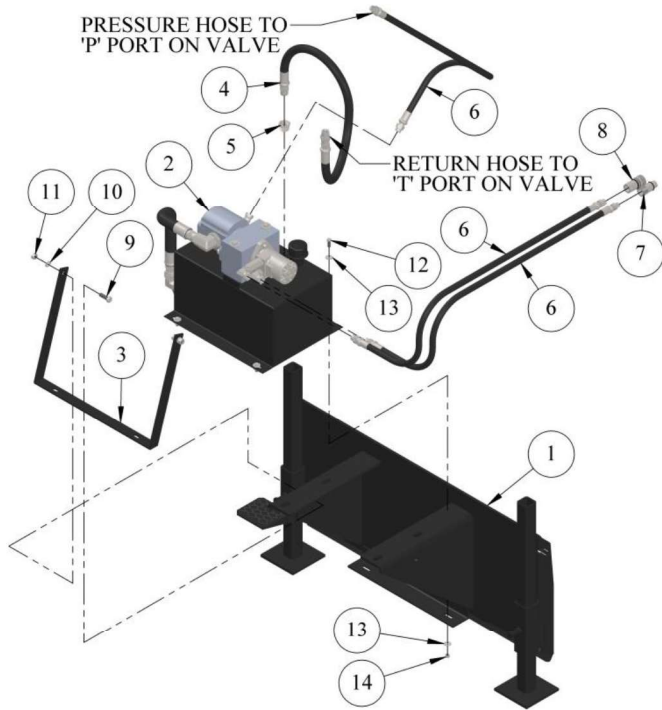

OH-200 - Self-Contained Mounting Package Assembly.

Item	Qty.	Part No.	DESCRIPTION
1	1	MBS-77-20	Bracket Assy., Universal Mtg.
2	1	OH-101-1	Pump/Motor Kit, Complete
3	1	OH-101-2B	Frame Weldment, Reservoir Bracket
4	1	SM-0252-R	Hose Assy., Hyd. 3/4" x 48" 3/4" MNPT
5	1	300340	Bushing, Reducer 1" NPT x 3/4" NPT
6	3	SM-1022-P	Hose Assy., Hyd. 1/2" x 54" 1/2" MNPT
7	1	CT-832-MC	Coupler, 1/2" Male Flat Face
8	1	CT-832-FC	Coupler, 1/2" Female Flat Face
9	2	300326	Screw, Cap 1/2 -13 x 3 Hew Head Gr5 Zn
10	2	300101	Washer, Lock 1/2 Zn
11	2	300102	Nut, Hex 1/2-13 Zn
12	4	300189	Bolt, Tap 3/8-16 x 1" Gr5 Zn
13	8	300178	Washer, Flat 3/8 Std. Zn
14	4	300181	Nut, Lock 3/8-16 Zn

IMPORTANT NOTICE

The following hydraulic fittings and hoses require a paste type sealer. Do not use a tape-type sealer, such as Teflon Tape, as this can contaminate the system and voids the valve warranty.

3. Install hoses as follows (see above). Screw in the Bushing Reducer (item 5) into the open port on the top of the tank next to the breather cap, then screw in one end of the 3/4" x 48" hose (item 4) into the Bushing Reducer. The other end of the hose goes to the 90° fitting in the 'T' port on the hydraulic control valve.
4. A 1/2" x 54" hose (item 6) connects to the 45° fitting in the hydraulic pump and the other end attaches to the 90° fitting in the 'P' pressure port on the top of the hydraulic control valve.
5. The other two (2) 1/2" x 54" hoses (item 6) connect to the 90° fittings in the hydraulic motor and the other ends attach to the Quick Couplers (item 7 & 8). The Female Coupler (item 8) connects to the hose going to the check valve on the hydraulic motor. The Male Coupler attaches to the other hose connected to the hydraulic motor.
6. The Self-Contained Mounting Package should look similar to below when completed.

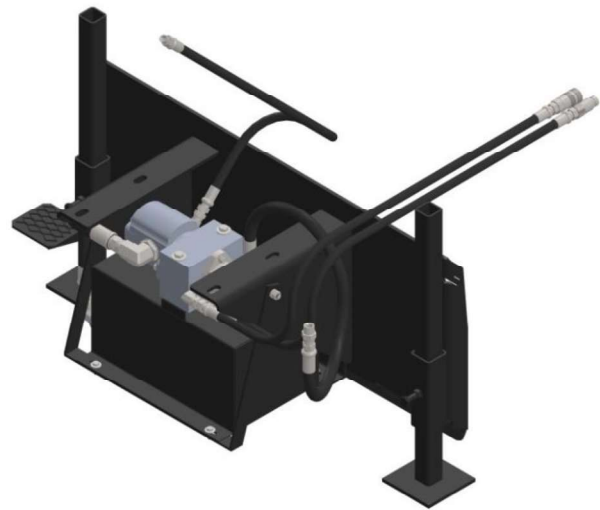

OH-200 - Self-Contained Mounting Package completely assembled.

Base Plate (Hydraulic or Manual)

NOTE: Hydraulic base plate installation is shown. Installation of manual base plate is similar.

1. Remove the carriage bolts, washers, and nuts from hydraulic base plate. Save the hardware for reuse.

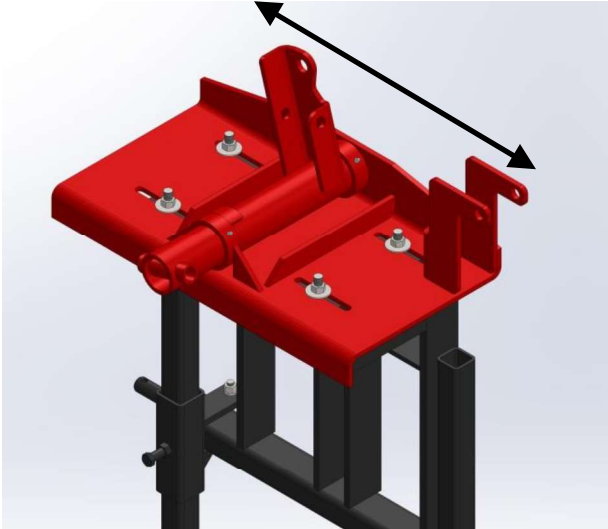

2. Install hydraulic base plate on three-point hitch weldment, as shown. Install carriage bolts, washers, lock washers, and nuts removed in Step 1. Center the base plate on the three-point hitch and tighten the hardware securely.
3. Install hydraulic cylinders on hydraulic base plate, along with scissor stop assembly as shown below. Secure with cotter pins (included).

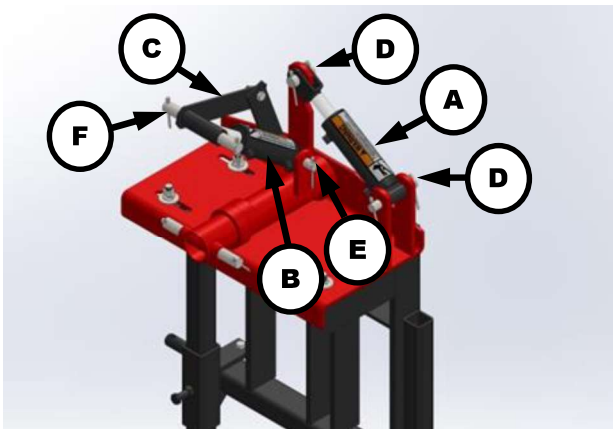

NOTE: Side tilt cylinder (A) is secured with cylinder mounting pins (D). Forward tilt cylinder (B) and scissor stop assembly (C) are secured with cylinder mounting pin (E) and channel mounting pin (F). Install supplied cotter pins in both ends of all mounting pins.

⚠ WARNING



The Main Carriage Channel Assembly is tall and heavy. To avoid tip over, resulting in serious injury or death, leave the overhead lifting device attached to the Main Carriage Channel while assembling components.



Proper lifting device (large arrow above) when attaching Driver to Base Plate.

Attaching the Driver to Base Plate.

- a. Position and align Driver with lower base plate pivot location (A above). Install the pin and secure with included cotter pins.
- b. Manually extend Forward Tilt Cylinder, align and install upper mounting pin (B above) and scissor stop safety lever (C above). Make sure scissor stop safety lever (C above) is installed on upper mounting pin (B above). Secure with included cotter pins.

NOTE: If using Manual Base Plate Assembly,

first position and align Driver with lower base plate pivot location (**A below**), then install mounting pin. Adjust forward tilt crank and side tilt crank to align upper mounting pin holes (**B below**), then install upper mounting pin. Secure pins with included cotter pins.

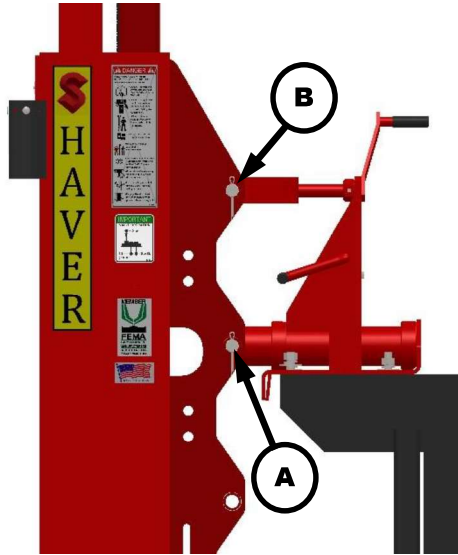

Manual Base Plate Assembly.

Connection to Hydraulic Supply

The customer must supply suitable hydraulic quick disconnect fitting for connecting pressure supply hose. For return hose to the tractor or power supply hydraulic system, use the appropriate adaptor listed for you tractor in the **TRACTOR LISTING** spread sheet, see your dealer or distributor.

Hydraulic Valve & Hose Installation

IMPORTANT NOTICE

Hydraulic system fittings that require a thread sealant must be installed with a paste-type sealer only. Do not use a tape-type sealer, such as Teflon Tape, as this can contaminate the system and voids the valve warranty.

Plate

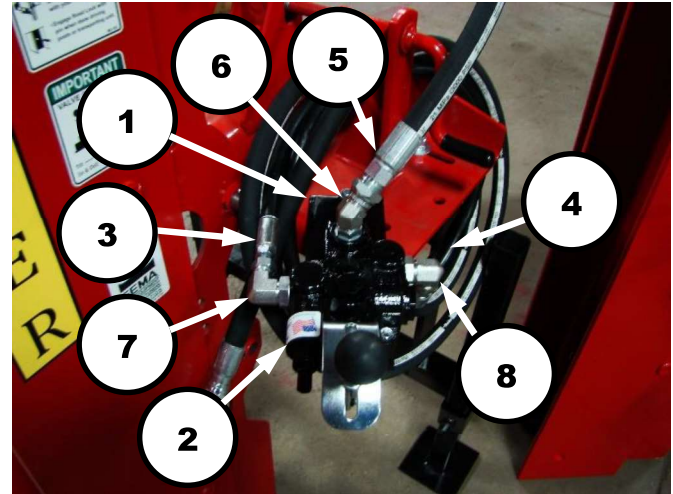

Manual Tilt Base Control Valve (see parts chart below).

Single Lever Control Valve for Manual Base Plate Parts List			
Item	Qty.	Part No.	Description
1	1	SM-001-PVBP	Plate, Valve Bracket VP-01
2	1	VP-01-SP	Valve - 1 Spool
3	1	SM-0234-P	Hose Assy., 1/2 x 120
4	1	SM-025-R	Hose Assy., 3/4 x 120
5	1	SM-0252-R	Hose Assy., 3/4 x 48
6	1	F-6902-10-12	Adapter, 45° SAE#10MORB-3/4FNPT
7	1	CTP-69011208	Adapter, 90° SAE#12MORB-1/2FNPS
8	1	SC-50-H52	Adapter, 90° SAE#12MORB-3/4FNPT

1. Remove the plugs from the hydraulic control valve.
2. Install the hydraulic valve (item 2) on Valve Bracket (item 1) using three (3) 5/16-18 x 2-1/2" valve mounting bolts, washers, and nuts. **NOTE: Do not over-tighten the hardware, which can warp valve body.**
3. Attach the valve and mounting bracket to the Driver Base Plate using base plate mounting hardware in the right rear side of the plate.
4. Screw in hydraulic fittings (items 6, 7, & 8) as shown above. The 45° SAE#10MORB-3/4FNPT Adapter (item 6) goes into 'B' working port on top of the valve. The 90° SAE#12MORB-1/2FNPS Adapter (item 7) goes into the 'IN' pressure port on the side of the valve. The 90° SAE#12MORB-3/4FNPT Adapter (item 8) goes into the 'OUT' side return port on the valve.

Single Lever Control Valve for Manual Base

Manual Tilt Base Control Valve hoses.



directly to the hydraulic reservoir of the tractor or skid loader.

IMPORTANT NOTICE

The hydraulic valve and cylinder(s) can be damaged by contamination (dirt and debris) from the oil in the tractor or power source. Ensure the oil is clean and properly filtered before connecting the Post Driver to a hydraulic power source. Failure to follow oil cleanliness standards voids the Shaver Post Driver warranty.

Triple Lever Control Valve for Hydraulic Base Plate

1. Remove the plugs from the hydraulic control valve.

5. Attach the hoses as follows (see above). Screw in one end of the 3/4 x 48" hose (item 5) to the 45° fitting in the 'B' working port on top of the valve and the other end to the port on the driver cylinder using paste-type thread sealant on the fittings. The 1/2 x 120 hose (item 3) connects to the 90° fitting in the 'IN' pressure port on the top of the valve and the other end is hooked up to the pressure hydraulic line from tractor. The 3/4" x 120 Return line hose is screwed into the 90° fitting from the 'OUT' port of the valve using paste-type thread sealant on the fitting.

6. For the other end of the return hose use the appropriate adaptor listed for you tractor in the **TRACTOR LISTING** spread sheet (see below) using paste-type thread sealant on the fitting.

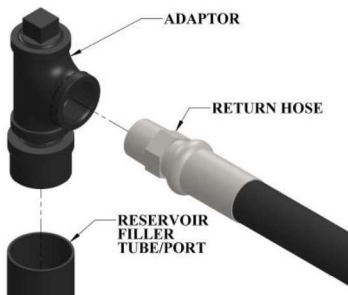

Return line and adaptor (SM-10-R Adaptor is shown).

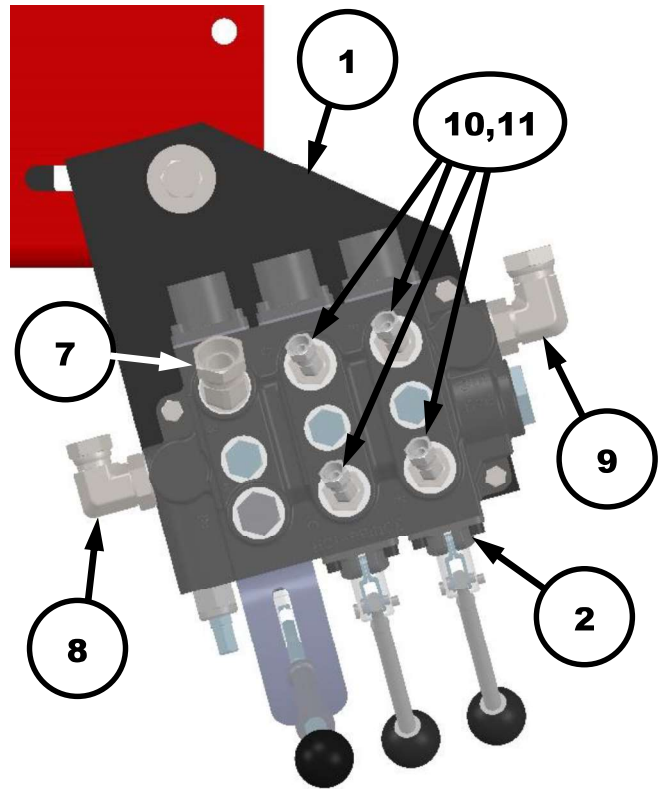

Hydraulic Tilt Base Control Valve fitting.

IMPORTANT: For the Driver to function properly the return line must be connected

2. Install the hydraulic valve (item 2) on Valve Bracket (item 2) using three (3) 5/16-18 x 2-1/2" valve mounting bolts, washers, and nuts.
NOTE: Do not over-tighten the hardware, which can warp valve body.
3. Attach the valve and mounting bracket to the Driver Base Plate using base plate mounting hardware in the right rear side of the plate.
4. Screw in hydraulic fittings (items 7, 8, & 9) as shown above. The 45° SAE#10MORB-3/4FNPT Adapter (Item 7) goes into 'B' working port on top of the valve. The 90° SAE#12MORB-1/2FNPS Adapter (item 8) goes into the 'IN' pressure port on the side of the valve. The 90° SAE#12MORB-3/4FNPT Adapter (item 9) goes into the 'OUT' side return port on the valve.
5. Then screw in hydraulic fittings for the Tilt Cylinders (items 10 & 11) as shown above. Four (4) straight SAE#10MORB-#6FORB Adapters (item 10) go into the 'C', 'D', 'E' & 'F' working ports on top of the valve. Then four (4) 45° SAE#6MORB-1/4FNPS Adapters (item 11) go into the straight adapters in 'C', 'D', 'E' & 'F' working ports on top of the valve.

Triple Lever Control Valve for Hydraulic Base Plate Parts List			
Item	Qty.	Part No.	Description
1	1	SM-003-PVBP	Plate, Valve Bracket VP-03
2	1	VP-03-SP	Valve – 3 Spool
3	1	SM-0234-P	Hose Assy., 1/2 x 120
4	1	SM-025-R	Hose Assy., 3/4 x 120
5	1	SM-0252-R	Hose Assy., 3/4 x 48
6	4	SM-02111-P	Hose Assy., 1/4 x 26
7	1	F-6902-10-12	Adapter, 45° SAE#10MORB-3/4FNPT
8	1	CTP-69011208	Adapter, 90° SAE#12MORB-1/2FNPS
9	1	SC-50-H52	Adapter, 90° SAE#12MORB-3/4FNPT
10	4	F-6410-10-06	Adapter, Str. SAE#10MORB-#6FORB
11	4	F-6902R-6-4-.03	Adapter, 45° SAE#6MORB-1/4FNPS

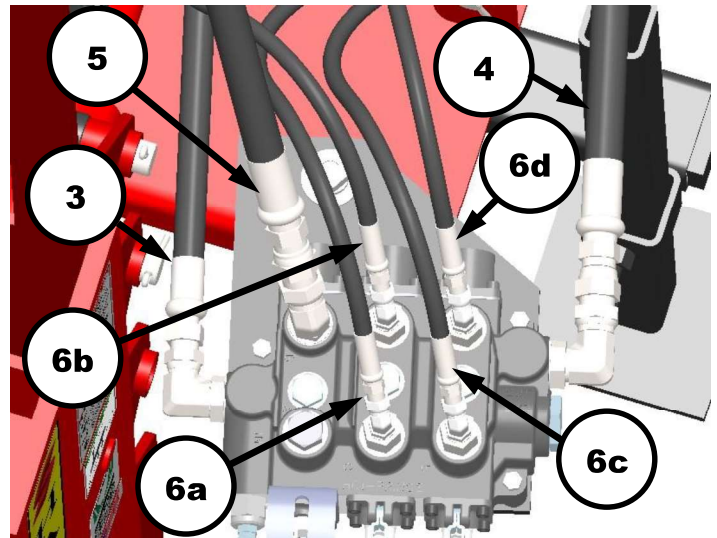

Hydraulic Tilt Base Control Valve hoses.

Hydraulic Hose Chart		
Item	Valve Port	Location
3	IN	Pressure Hose
4	OUT	Return Hose
5	B	Driver Cylinder
6a	D	Forward Tilt Cylinder Rod End
6b	C	Forward Tilt Cylinder Base End
6c	F	Side Tilt Cylinder Rod End
6d	E	Side Tilt Cylinder Base End

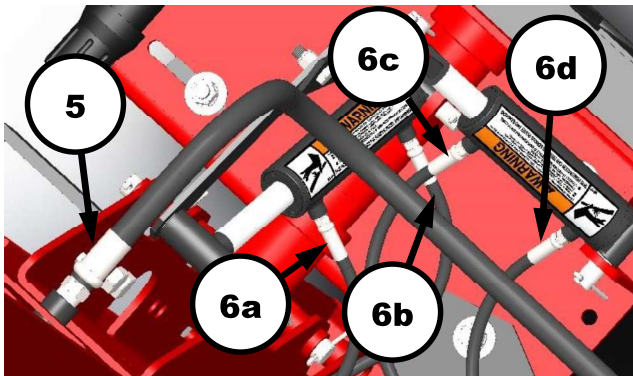

Driver hydraulic hoses.

6. Attach the hoses as follows (see above). Screw in one end of the 3/4" x 48" hose (item 5) into the port on the driver cylinder using paste-type thread sealant on the fitting. The four (4) 1/4 x 26" hoses (items 6a, b, c, & d) connect to the four (4) ports on the tilt cylinders using paste-type thread sealant on the fittings.

7. Attach the other ends of the hoses as follows (see above). Screw in one end of the 3/4 x 48" hose (item 5) to the 45° fitting in the 'A' working port on top of the valve using paste-type thread sealant on the fittings. The 1/2 x 120 hose (item 3) connects to the 90° fitting in the 'IN' pressure port on the side of the valve using paste-type thread sealant on the fittings and the other end is hooked up to the pressure hydraulic line from tractor. The 3/4" x 120

hose is screwed into the 90° fitting from the 'OUT' port of the valve using paste-type thread sealant on the fittings.

- Attach the tilt cylinder hoses as follows (see chart & illustration on the left). Attach the other end of the hose connected to the rod end of the side tilt cylinder (item 6a) to the 45° fitting from the 'D' port of the valve using paste-type thread sealant on the fitting. Then attach the other end of the hose connected to the base end of the side tilt cylinder (item 6b) to the 45° fitting from the 'C' port of the valve using paste-type thread sealant on the fitting. Do the same with the forward tilt cylinder hoses. The rod end hose (item 6c) goes to the 45° fitting from the 'F' port of the valve and the base end hose (item 6d) goes to the 45° fitting from the 'E' port of the valve.

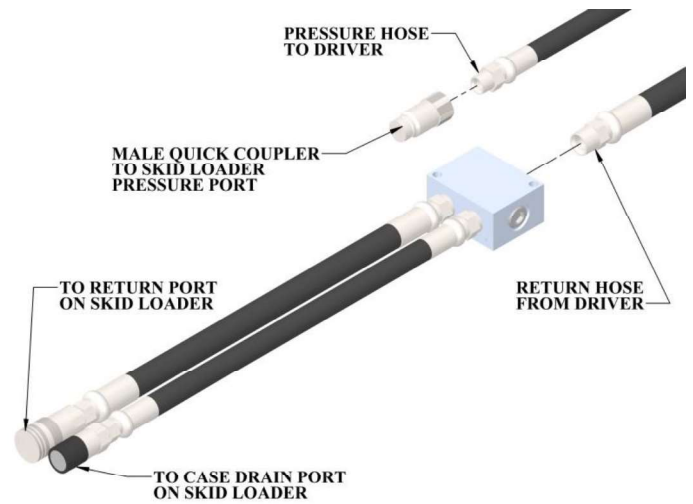

Skid Loader Hydraulic Splitter Return Kit (above).

IMPORTANT NOTICE

If the tilt cylinder hoses are attached differently than shown, the control of the drive ram will not be as described in this manual.

IMPORTANT: For the Driver to function properly the return line must be connected directly to the hydraulic reservoir of the tractor or skid steer.

NOTE: Make sure all hose fittings are tight.

Rubber Debris Guard

- For the other end of the return hose use the appropriate adaptor listed for your tractor in the **TRACTOR LISTING** spread sheet.

- Locate rubber debris guard and bag containing hardware and caution tag.

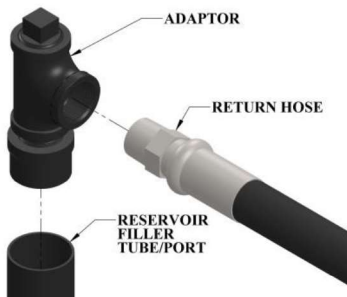

Return line and adaptor (SM-10-R Adaptor is shown).

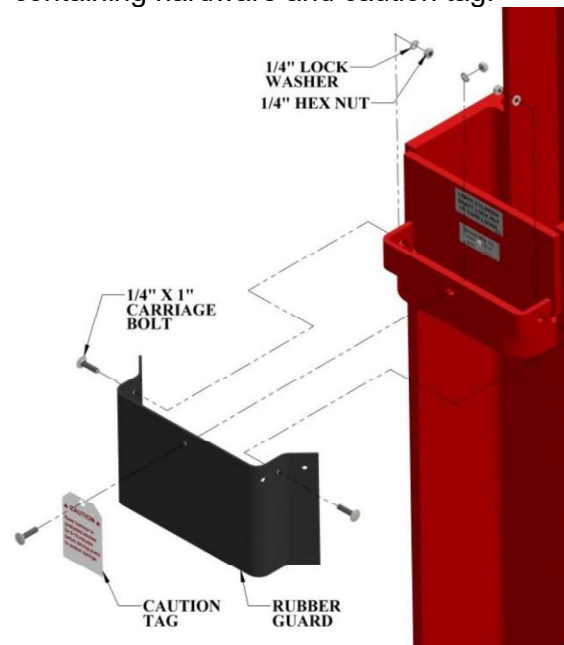

HD-8/10/12 Rubber Debris Guard mounting (HD-10 shown).

- For a skid steer/loader with a case drain, use the Skid Loader Hydraulic Splitter Return Kit (P/N **SM-SL-HSRK**). To attach it to the Driver, use pipe thread sealant to screw the Driver Return Hose into the open port (#3) on the valve. Attach the Male Quick Coupler using pipe thread sealant to the pressure hose that goes to the driver valve. Then plug the quick couplers into the skid steer/loader ports as called out below.

- For HD-8/10/12 attach the Rubber Guard and Caution Tag on drive ram, with guard mounting hardware, three (3) 1/4-20 x 1" Carriage Bolts, Lock Washers, and Nuts, as shown above.

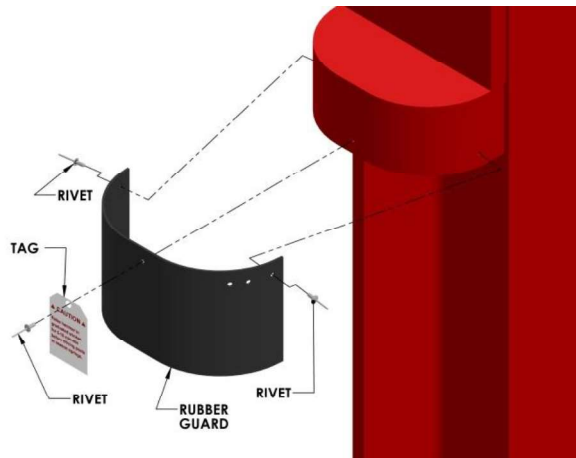

SHD-10 Rubber Debris Guard mounting.

3. For SHD-10 attach the Rubber Guard and Caution Tag on drive ram, with guard mounting hardware, three (3) 3/16" x 3/8 blind rivets, as shown above.

NOTE: To avoid damage to the Rubber Debris Guard, do not over-tighten the mounting hardware.

Safety Arm Assembly

! WARNING



To avoid serious injury or death, the safety arm must be installed after the Post Driver has been mounted on a machine, or the freestanding Post Driver has been secured to prevent tipping.

1. Locate safety arm assembly parts and hardware.

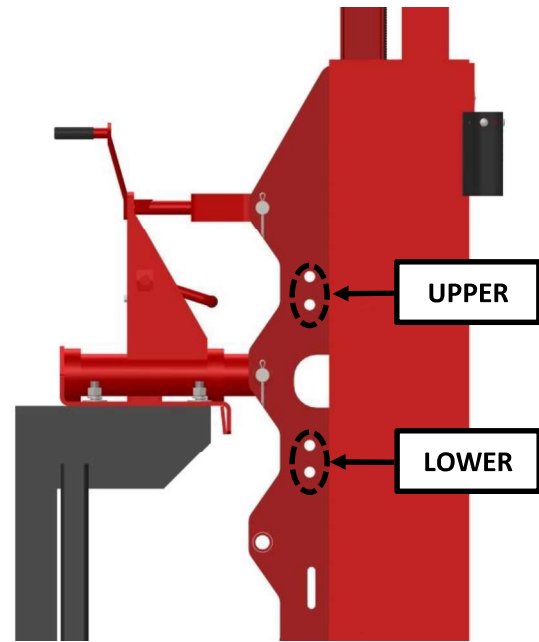

Safety Arm Mounting holes (HD-10 with manual base plate shown).

2. Locate the set of two (2) mounting holes in the Stabilizer Channel to be used to attach the Safety Arm.

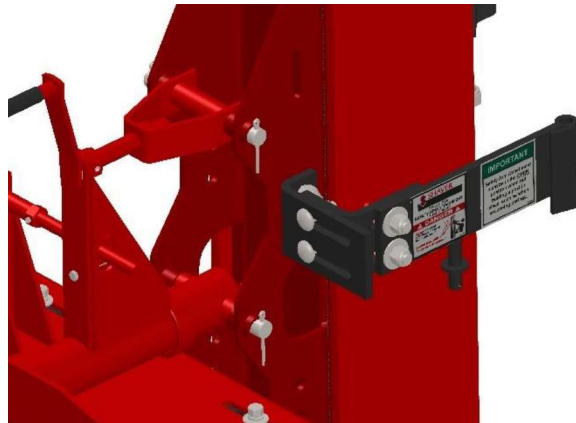

Safety Arm Mounting Bracket in Upper Position (HD-10 with Manual Base Plate shown).

3. Attach safety arm frame to inside of stabilizer channel with two (2) 3/4-10 x 2" bolts and self-locking nuts, as shown above. Tighten nuts securely.

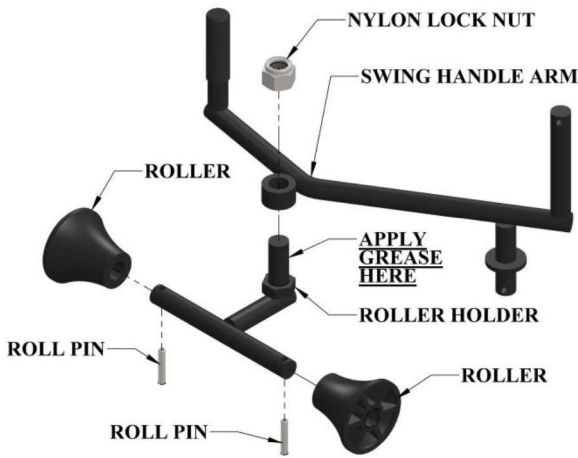

Safety Swing Arm & Roller Holder assembly

4. Assemble two Rollers onto Roller Holder and secure with two Roll Pins, as shown above.
5. Apply a light film of good quality grease to the pivot shaft and attach Roller Holder to Swing Handle Arm with Nylon Lock Nut as shown above. Tighten Nut until seated and then loosen 1/4 to 1/2 turn.

NOTE: Roller Holder must swivel freely on Swing Handle Arm.

⚠ WARNING



To avoid serious injury or death, the safety arm must be installed after the Post Driver has been mounted on a machine, or the freestanding Post Driver has been secured to prevent tipping.

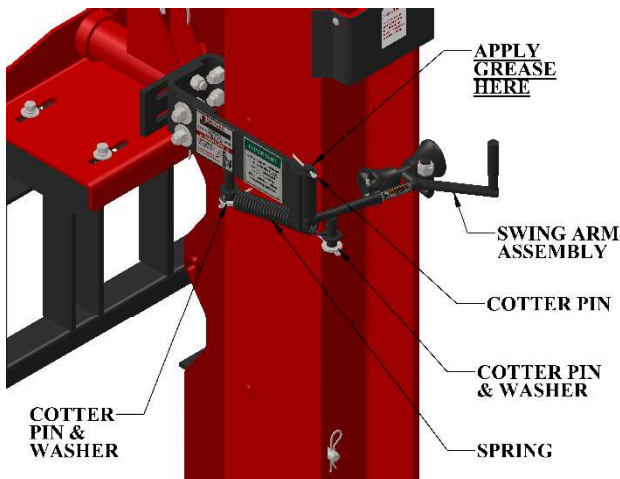

Safety Arm Mounting (HD-10 shown)

6. Install the Swing Arm Assembly.
 - a. Apply a light film of good quality grease to the pivot shaft on Swing Arm Assembly.
 - b. Slide the pivot shaft into the tube on the Safety Arm Mounting Bracket and secure with cotter pin as shown above.
 - c. Slide the open spring eye over the Mounting Bracket anchor rod and secure with a flat washer & cotter pin.
 - d. Slide the other end of the spring eye over the anchor rod on the Swing Arm Assembly and secure with a flat washer & cotter pin.

7. Verify the swing arm handle opens against safety arm frame stop bracket and closes against back wall of drive ram I-beam.



Drive Ram and Safety Arm with fence post.

NOTE: When driving a fence post, the swing arm rollers must contact and hold the fence post in position, as shown above.

Document Storage Tube



Manual Storage Tube & mounting rivets.

1. If desired, locate the document storage tube in a convenient location on the Post Driver. The photo below shows the tube mounted on the base plate, but other locations are acceptable.

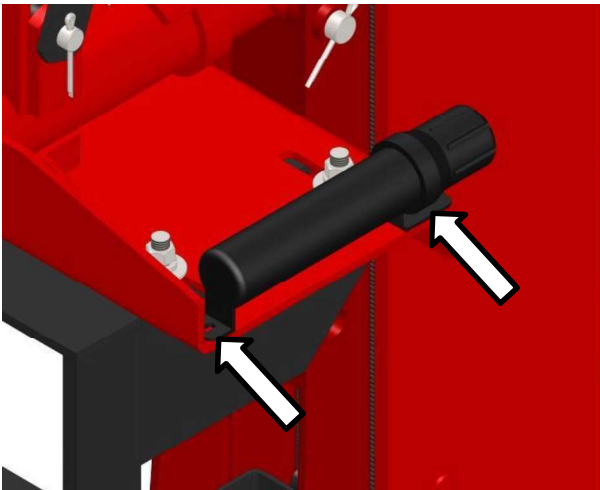

Manual Storage Tube mounted on Base Plate.

2. Mark the location of the two mounting holes using the storage tube as a guide (arrows above).
3. Drill two 3/16" holes.
4. Attach the storage tube with the two pop rivets supplied inside the tube.

Attachments and Options Assembly Steel Post Holder Accessory



Steel Post Holders for HD-8 shown. Steel T-Post Holder on left and Steel Square Post Holder on right.

Stabilizer (2 Foot) Extension Accessory

For driving 11-12-foot posts.

1. Drill two (2) holes (9/16") in foot plate of Stabilizer as shown below.

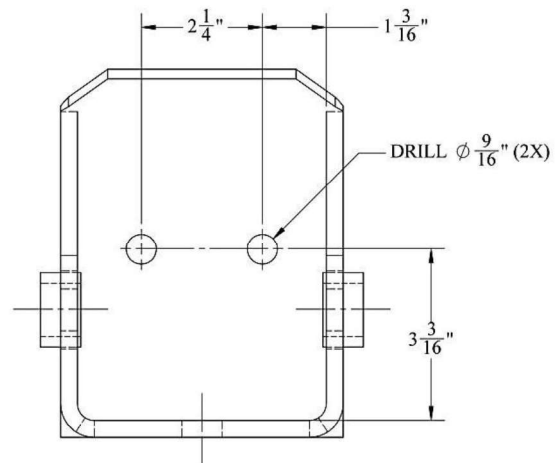

HD-8 mounting hole locations in Stabilizer Foot.

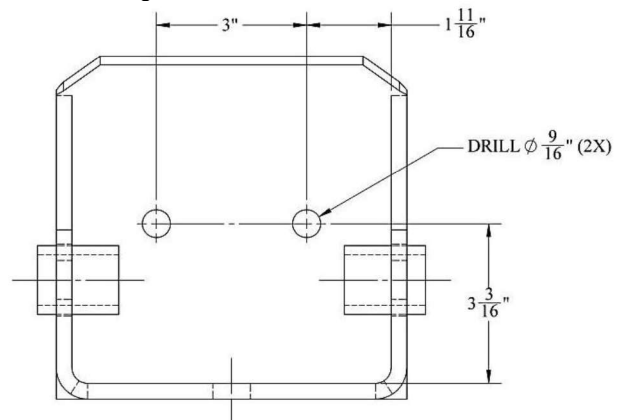

HD-10/SHD-10 mounting hole locations in Stabilizer Foot.

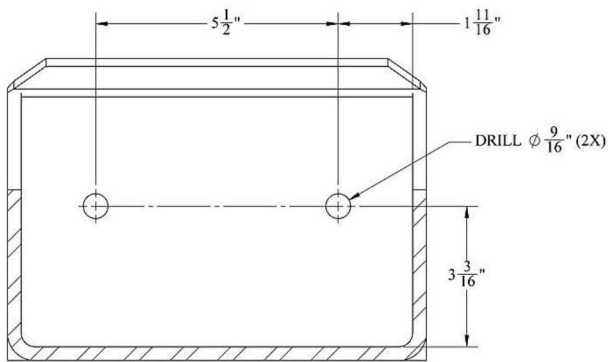

HD-12 mounting hole locations in Stabilizer Foot.

- Secure with supplied mounting hardware as shown below.

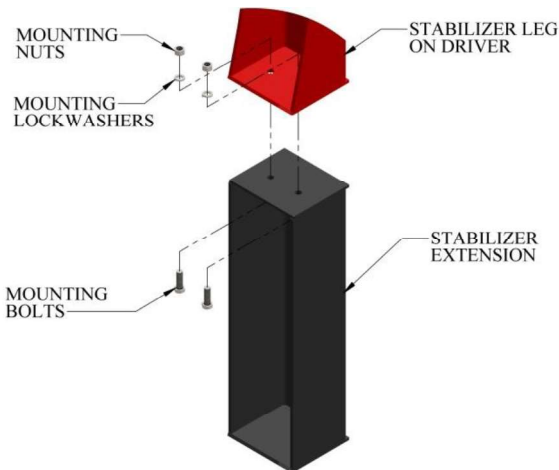

Attaching Stabilizer Extension to Stabilizer Leg on Driver (HD-10 shown).

Pilot Auger Accessory

For Pilot Auger Accessory assembly and operation see the instruction sheet that is supplied with the Pilot Auger.

Post Driver Operation

Operational Safety Tips

- Follow all safety information contained in this manual and refer to safety decals located on the Post Driver.
- Personal safety equipment must be worn at all times during operation, i.e. safety glasses, steel toe shoes, hearing protection, etc.
- Always stand 45 degrees to the right of the post while the Post Driver is in operation.
- Do not** remove any of the Post Driver safety equipment or safety labels.

- All Post Driver safety equipment must be inspected, maintained, kept in working order, and used during Post Driver operation.
- Do not** place your hand(s) on top of the post when placing the post in the PostDriver or while the Post Driver is operating.
- Leave the Safety Arm Attachment open when not holding a post, except when transporting the Post Driver.
- Do not** remove the hydraulic control valve safety lever stop.
- Never use the maximum force of the Post Driver until the post being driven is started into the ground and is straight.
- Use caution when driving small diameter wood or steel posts. Maximum driving impact is not necessary.
- Always be aware of the environment in which you are operating the Post Driver.
- Do Not** operate the Post Driver on steep slopes, as this could cause a roll over.
- Always check for underground utilities, i.e. wires, gas lines, waterlines, etc. Call your local utility companies for underground utility locations.
- Use caution where large rocks or other objects could be hidden underground and not visible to the operator. The post could splinter and cause injury to the operator. If the post fails to drive into the ground after two or three strikes, move to another location.
- Do not** operate the Post Driver with the machine or power source unattended. The Post Driver requires two people for proper operation - one operating the Post Driver and one on the tractor.
- Always engage the Road Lock Pin in the Drive Ram upper hole before transporting.

Operating Instructions

3-Point Hitch Mounting

- With the Post Driver positioned on a hard level surface, move the tractor or other power supply toward the Post Driver until the three-point hitch lines up.
- Attach two lower, three-point hitch lift arms to Post Driver three-point hitch weldment hitch pins ('A' below). Secure with lock pins (operator supplied).

3. Attach the three-point top link to removable pin ('B' below) and secure with cotter pin.

NOTE: Adjust the length of the machine's top link, as required, to correctly attach the Post Drivers 3-Point Mounting Bracket.

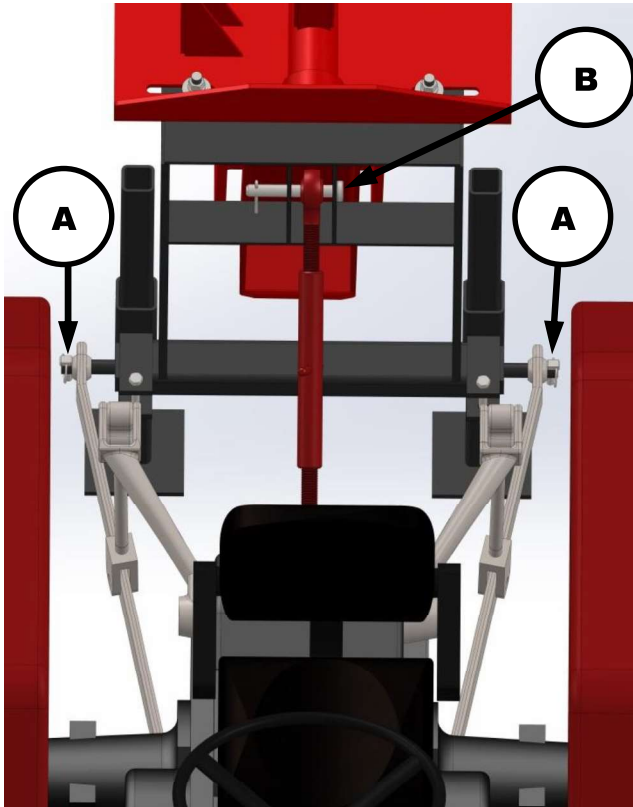

Three-Point Hitch Assembly, Top Link Pin, & Cotter Pin.

NOTE: The HD-8 Post Driver will fit tractors with Category I or Category II three-point hitches. Use bushings on hitch pins, if required, to correctly install lift arms.

NOTE: The HD-10, SHD-10, & HD-12 Post Drivers will fit tractors with Category II or Category III three-point hitches. Use bushings (Owner/operator supplied) on the hitch pins, if required, to correctly install the lift arms.

4. Attach hydraulic pressure supply hose (small diameter) to the tractor pressure supply port. Attach hydraulic return hose (larger diameter) to hydraulic fill port/tube.

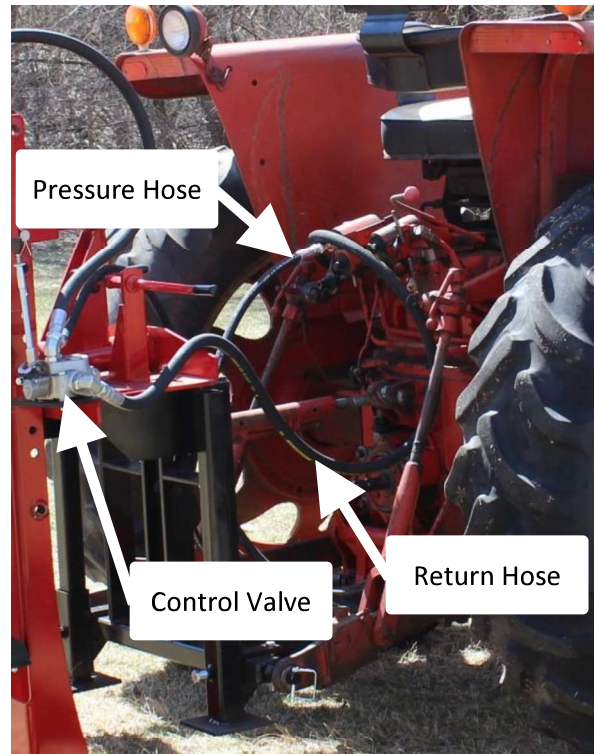

Control Valve, Hydraulic Pressure Hose, and Hydraulic Return Hose.

NOTE: The operator is responsible for installing quick-disconnect fittings (or other suitable fittings) on the Post Driver hoses. Make sure the fittings are compatible with the tractor hydraulic fittings.

5. When traveling always install the road lock pin (arrow below) in the "transport" position as shown below. The Post Driver can now be moved to the work site.



Drive Ram & Road Lock Pin in transport position.

Operating Instructions

Self-Contained Mounting

1. With the Post Driver positioned on a hard level surface, move the skid loader or other

quick attach bracket equipped unit toward the Post Driver until the plates line up. Lift the Driver off the ground and lock with the skid loader locking arms.

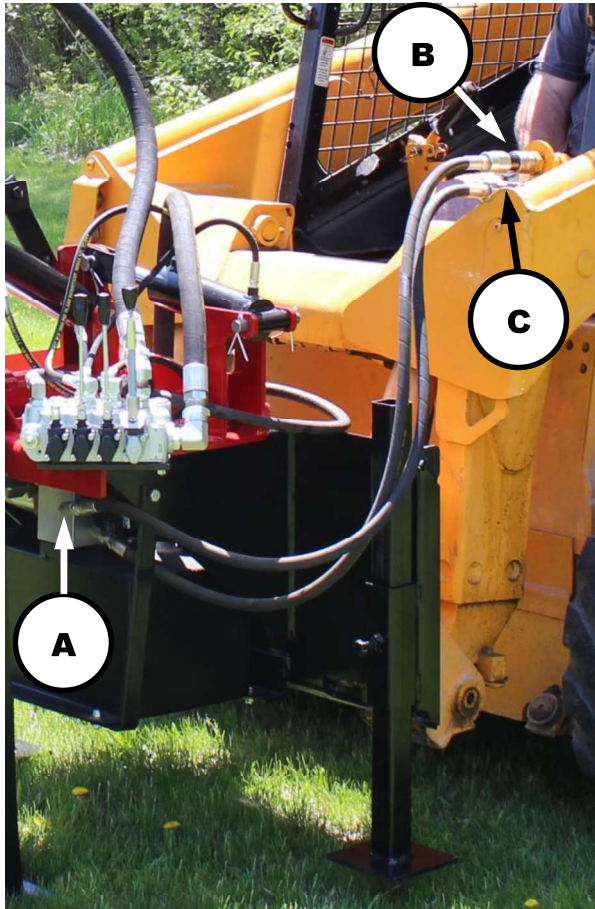

Self-Contained mounting and hydraulic hook-up to skid loader.

2. Locate the hose connected to the check valve (A) attached to the hydraulic motor. This is the pressure hose. Connect the quick coupler to the skid loaders hydraulic pressure source (B). The other quick coupler is connected to the return line (C). See above.

Preparing to Drive a Post

IMPORTANT NOTICE

If operating on uneven ground, make sure the stabilizer leg firmly contacts the ground at each new fence post location. Failure to do so can cause damage to the Post Driver components.

1. Position the tractor or power source in place to drive the first fence post.
2. Set the brakes on the tractor or power supply. If the machine is equipped with an automatic transmission, the transmission must be in

PARK.

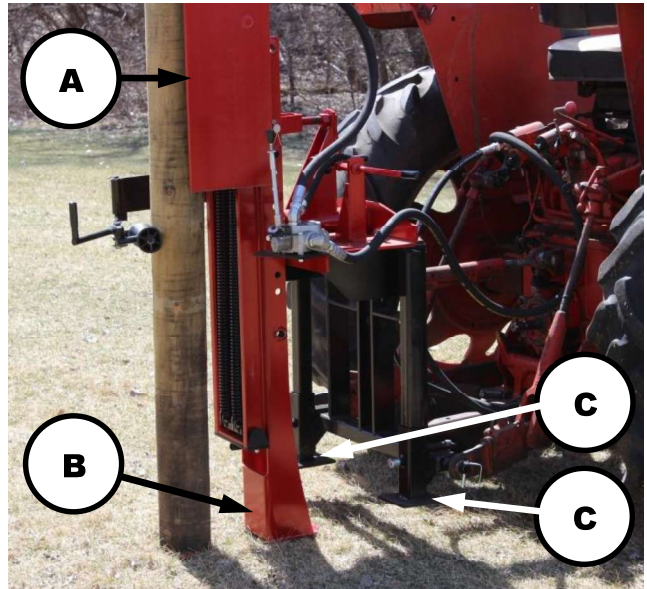

Drive Ram, Stabilizer, & Storage Legs.

IMPORTANT: When operating the Ram ('A' above) to drive in posts, the Stabilizer ('B' above) must be positioned on the ground. The Storage Legs ('C' above) are not used during operation of the Driver and should be in the raised position, off the ground when driving posts; they are for storage of the Driver only.

3. Remove Road Lock Pin ('D' below) and lower Driver until the Stabilizer ('B' below) rests on ground. Store Road Lock Pin in a secure location.

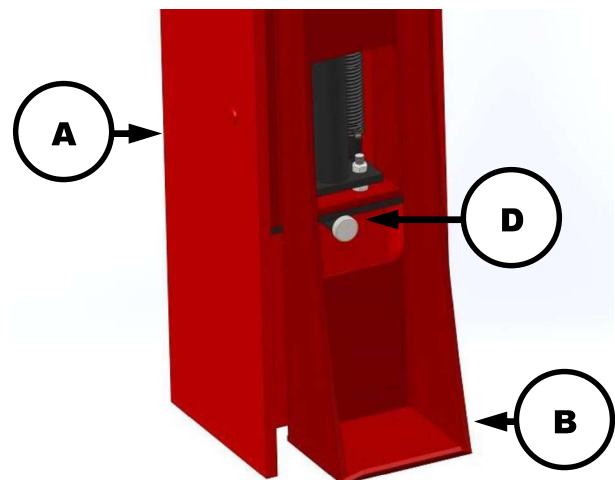

Drive Ram, Stabilizer, & Road Lock Pin.

Driving a Post

1. Lubricate four (HD-8/HD-10) or six (SHD-10/HD-12) guide blocks/rollers with oil before each daily use and, if necessary, between post installations.

IMPORTANT NOTICE

Do not use grease on the guide blocks or in the main carriage channel. Grease will retain abrasive material, which will result in premature wear.

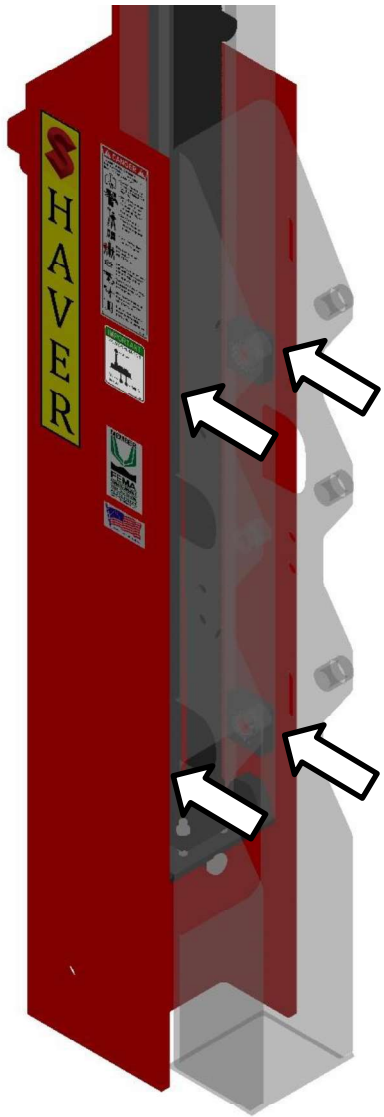

Guide Block/Roller locations (arrows) on Driver (HD-10 shown with transparent Main Carriage).

! WARNING



To avoid personal injury or death, do not operate the Post Driver by yourself. Always have another person to control the machine or power source.

NOTE: For operation of valve control levers refer to the illustration below.

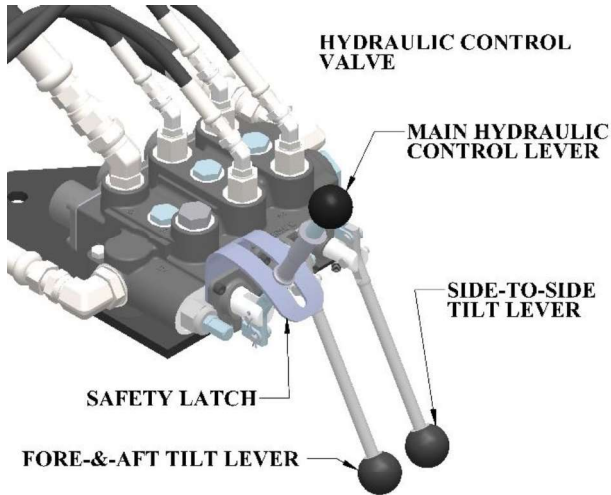

Valve control lever operation.

IMPORTANT NOTICE

If the tilt cylinder hoses are attached differently than shown, the control of the drive ram will not be as described in this manual.

2. Pull up Safety Latch and pull back Main Hydraulic Control Lever to raise Drive Ram.

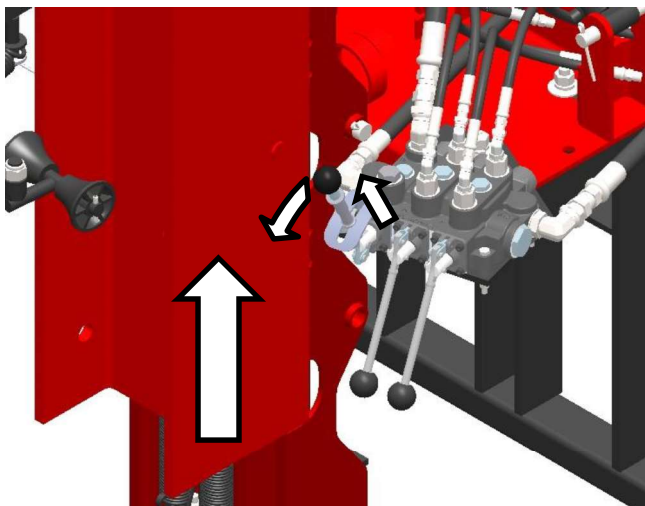

Drive Ram, Hydraulic Control Valve Lever, & Safety Lever.

3. Pull up Safety Latch and push Main Hydraulic Control Lever to lower Drive Ram.

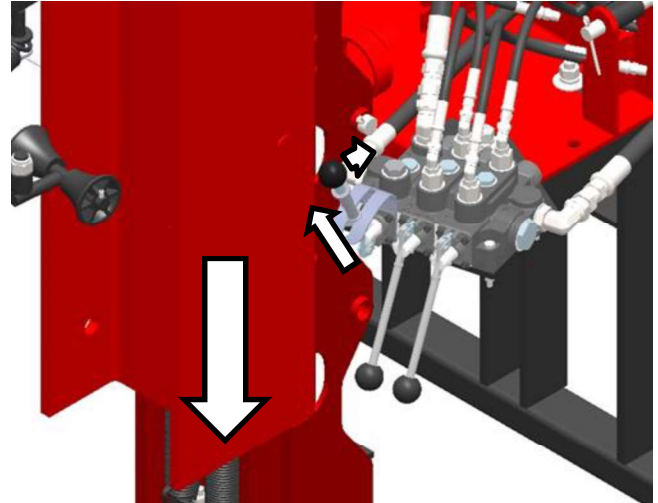

Drive Ram, Hydraulic Control Valve Lever, & Safety Lever.

IMPORTANT NOTICE

AT THE BEGINNING OF EACH DAY, USE THE MAIN HYDRAULIC CONTROL LEVER TO CYCLE THE DRIVE RAM UP AND DOWN 10 TO 15 TIMES, WITHOUT IMPACT WITH A POST OR THE GROUND, TO "SEASON" THE DRIVE RAM RETURN SPRINGS. FAILURE TO FOLLOW THIS RECOMMENDATION CAN CAUSE DAMAGE TO THE SPRINGS.

NOTE: THE TRACTOR OR OTHER POWER SOURCE MUST BE CAPABLE OF MAINTAINING ADEQUATE HYDRAULIC PRESSURE (ENGINE RPM) TO SMOOTHLY OPERATE (CYCLE) THE POST DRIVER.

⚠ WARNING



Potential Pinch Points. Keep hands clear of Post Driver while operating. Never place hand(s) on top of a post when inserting it into the Post Driver. Always close the safety arm when driving the post.

4. With the drive ram in the raised position and the safety arm swung out of the way, place a fence post in the I-beam, under the drive ram hammer plate.

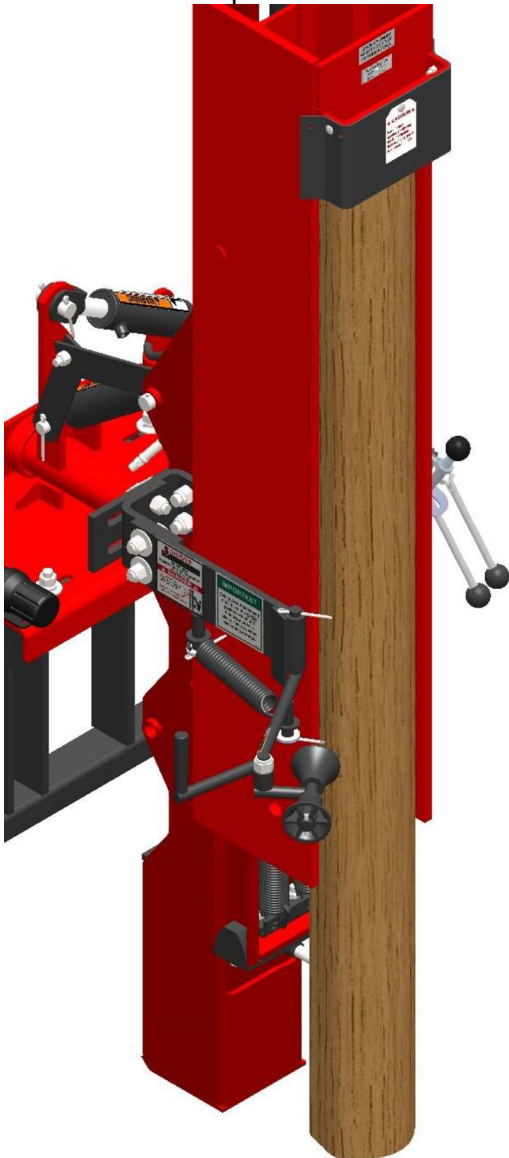

Positioning post in driver.

NOTE: There should be a 1" to 2" gap between the top of the fence post and the bottom of the drive ram hammer plate. Never drive a fence post without the guard in place.

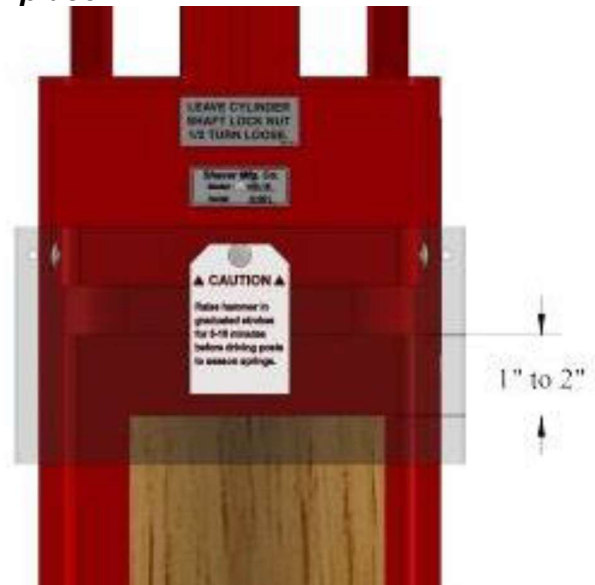

Post to hammer plate gap shown with a transparent Debris Guard.

5. Close safety arm frame to secure the post (the adjustable roller assembly keeps tension on the post while it is being driven).

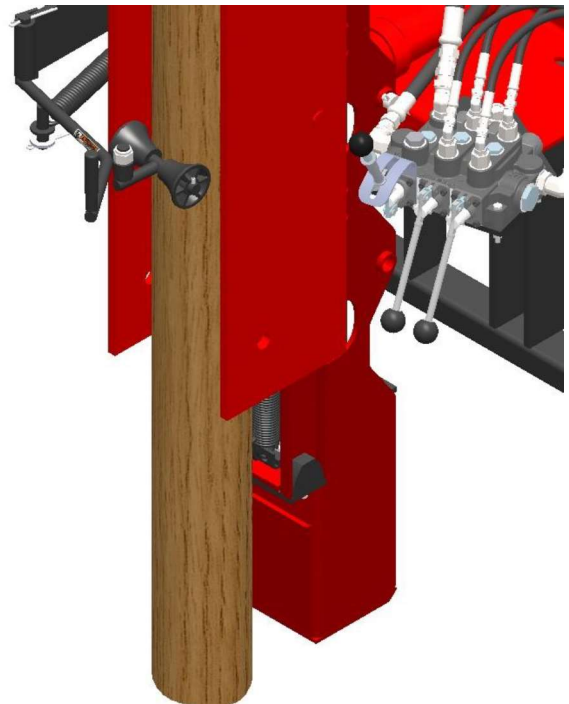

Safety Arm closed onto post.

6. **Do not** stand in front of the drive ram while operating the Post Driver. Stand at a 45-degree angle to the side of the Post
7. To drive the fence post straight, adjust the main carriage channel side-to-side and fore-and-aft using manual cranks (manual base plate) or second and third hydraulic control valve levers (hydraulic base plate).

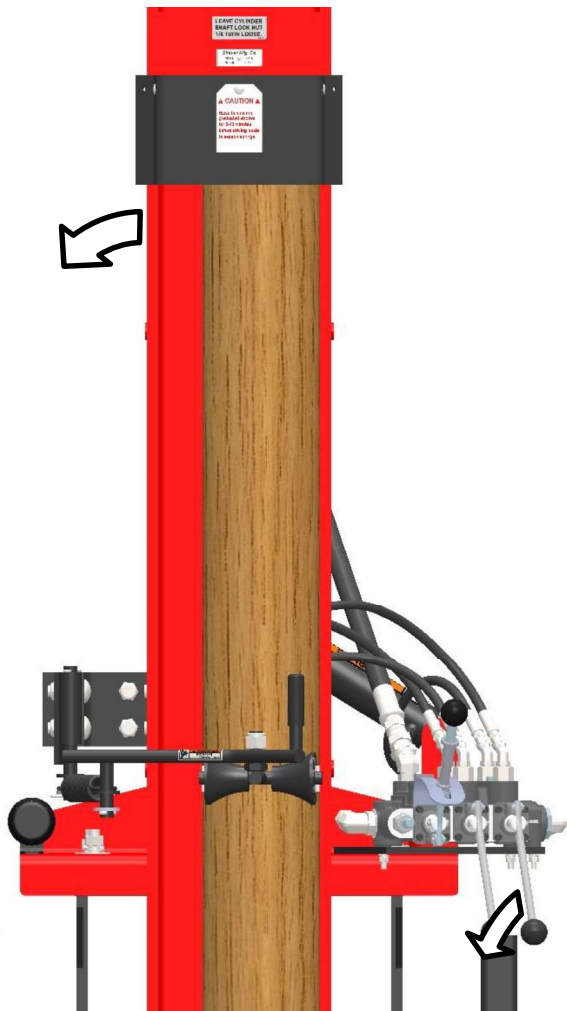

Tilt top of Drive Ram away from operator push the end lever away from the operator.

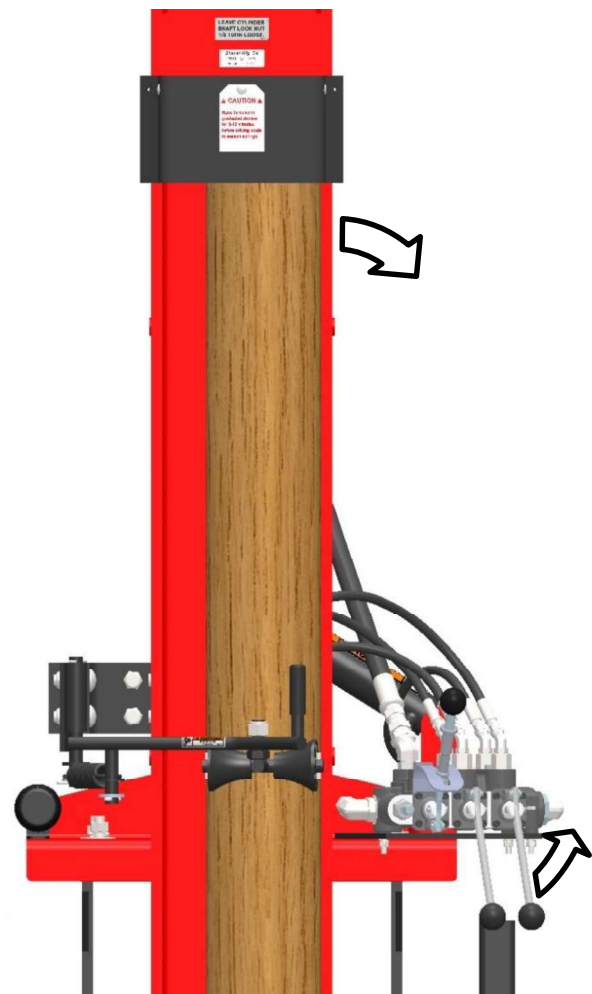

Tilt top of Drive Ram toward operator pull the end lever toward the operator.

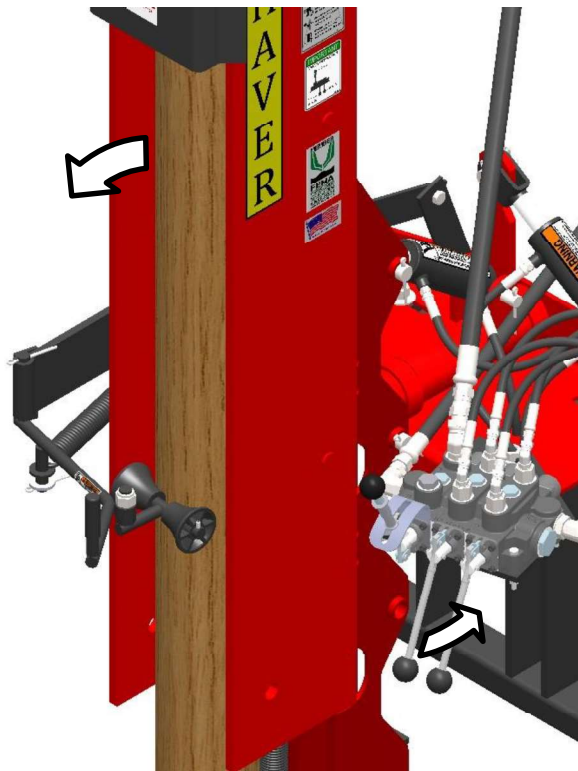

Tilt top of Drive Ram away from tractor/skid loader push middle lever away from the operator.

8. Pull up Safety Latch and pull back Main Hydraulic Control Lever to raise Drive Ram.

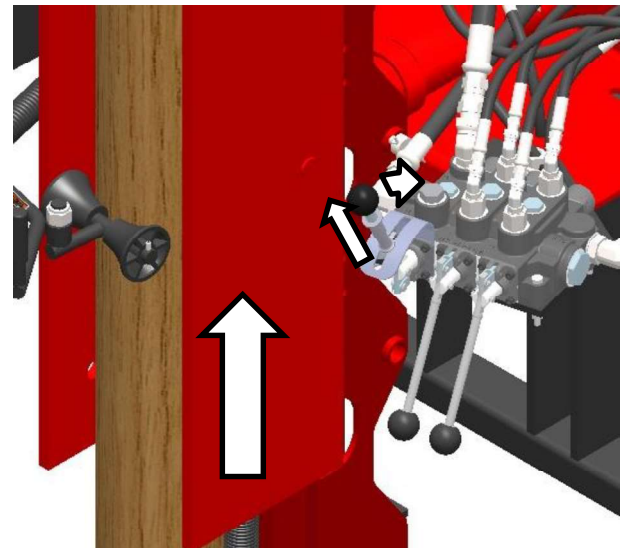

Drive Ram, Hydraulic Control Valve Lever, & Safety Lever.

9. Hold up Safety Latch and push Main Hydraulic Control Lever to release the Drive Ram and create impact with post. Continue this process, as needed, to drive the post to the desired depth.

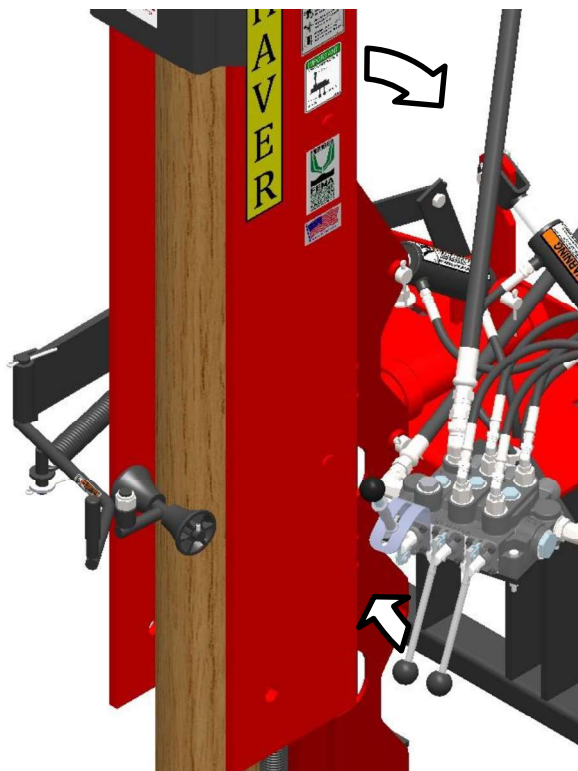

Tilt top of Drive Ram toward tractor/skid loader pull middle lever toward the operator.

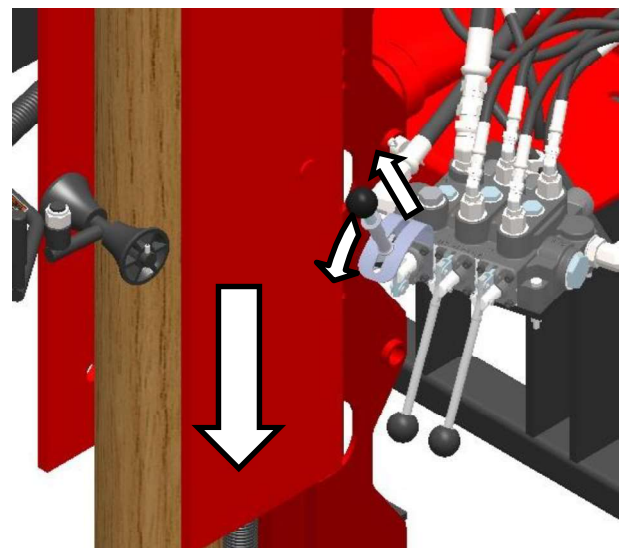

Drive Ram, Hydraulic Control Valve Lever, & Safety Lever.

IMPORTANT NOTICE

Posts will drive into the ground much straighter using shorter strokes. Use caution when driving small diameter wood and steel posts. Maximum impact is not necessary with these smaller diameter posts and can cause damage (splintering or breakage) of posts.

NOTE: If the post stops going down or is crooked after a few impacts, stop and move the post to a different location. Conditions such as thick sod, rocks, or tree roots can cause splintered or broken posts.

10. Once a post is driven to the desired depth, or the drive ram contacts the ground, release the hydraulic control lever.
11. Open safety arm frame.
12. Raise the Post Driver and move to the next location to begin driving a new post.
13. If traveling more than 100 feet, install road lock pin in upper "transport" position. The Post Driver can now be moved to the next work site or the storage location.

Dismounting Post Driver

1. Install road lock pin in upper "storage" position (lower hole is not used). The Post Driver should be stored on a hard level surface.

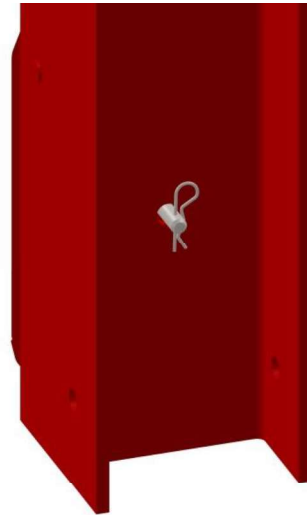

Road Lock Pin location (arrow).

2. Raise or lower the storage legs (small arrows) to allow drive ram I-beam (large arrow) full contact with the ground. Make sure the Post Driver is stable.

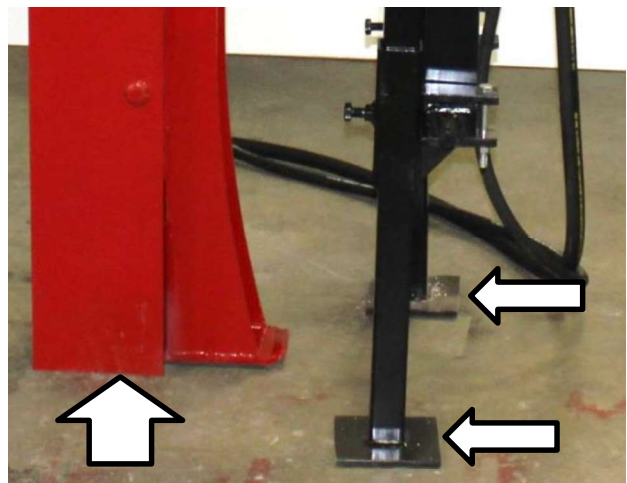

Drive Ram and Storage Legs.

NOTE: On units without storage legs, store the unit against a post driven into the ground. Position the unit with the driving ram next to the post and secure with a chain wrapped securely around the post and Post Driver.

! WARNING



On hydraulic tilt Post Drivers, to prevent the forward tilt cylinder from drifting, tighten the bolt and nut on the cylinder scissor stop. Failure to tighten this bolt and nut could allow the dismantled Post Driver to fall

over, causing serious injury or even death.

3. On hydraulic tilt Post Drivers, tighten the nut on cylinder Scissor Stop bolt (see arrow below) to prevent the cylinder from drifting and causing an unstable condition with the Post Driver.



Cylinder Scissor Stop Bolt.

NOTE: Failure to tighten this bolt could allow the Post Driver to fall over, causing serious injury or even death.

4. Make sure all pressure is released (zero pressure) from the Post Driver hydraulic system. Disconnect hydraulic pressure supply hose (A) from the tractor or skid loader. Disconnect hydraulic return hose (B) from the tractor or skid loader, see below.

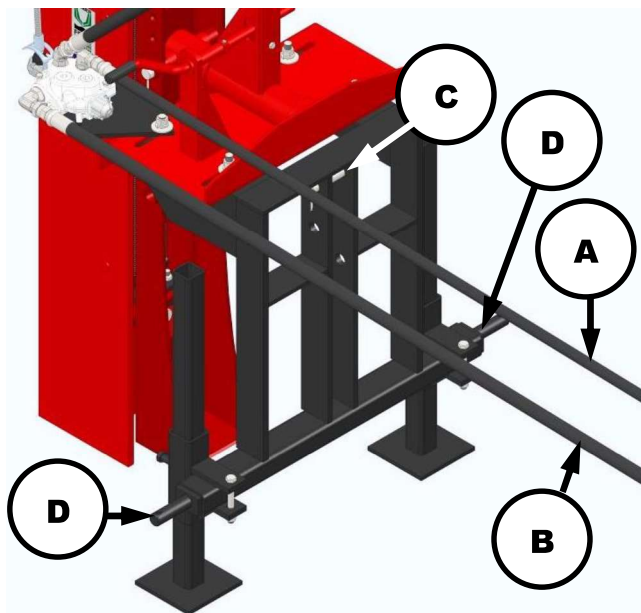

Hydraulic Pressure Supply Hose (A), Hydraulic Return Hose (B), Top Link Pin (C), and Lower Lift Arms (D).

5. For 3-Point Hitch remove top link pin (C) from weldment and disconnect top link. Then disconnect the two tractor lower lift arms from the lower hitch pins (D) to separate the tractor three-point hitch from the Post Driver, see above.
6. Carefully move the tractor or power source away from the Post Driver.

Service Procedures

⚠ WARNING

To avoid personal injury or death, carefully read and understand all instructions before attempting to assemble and/or operate the Post Driver. Do not operate or work on equipment unless you read and understand the instructions and warnings in this and all other applicable manuals. Contact



Shaver Manufacturing Company if any of the instructions provided are unclear or not understood. Proper care is your responsibility. Always follow all State and Federal health and safety laws and/or local regulations.



To help prevent personal injury, protective equipment must be worn during Post Driver assembly, operation, and maintenance. Personal protective equipment should include, but not be limited to, safety glasses, hearing protection, protective gloves, and steel toe footwear.



Before making any adjustments on the Post Driver, ensure that all hydraulic levers are in the neutral position. Always shut off the machine, set parking brake, and remove key before performing any service.



Personal injury can result from slips or falls. **DO NOT** leave tools or parts lying around the work area and clean up all spilled fluids immediately.

NOTE: Disassembly, assembly, and/or

associated repairs must be performed with the main carriage channel and drives ram in a horizontal position, such as on a suitable pallet, or heavy-duty support stands.

Refer to Dismounting Post Driver from Machine/Power Source section for steps to remove Post Driver from a tractor or other power source.

Dismounting Post Driver from Base Plate

1. Secure the Post Driver upright to an appropriate overhead lifting device to prevent tipping (large arrow below).

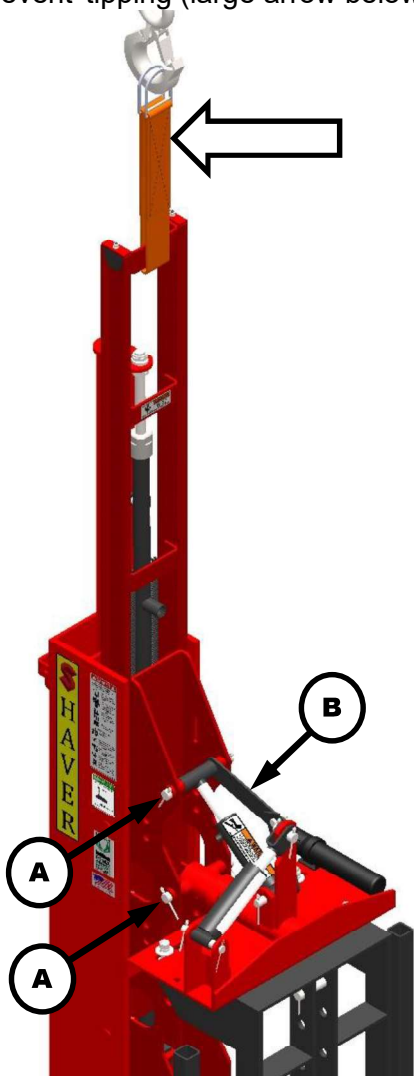

Proper lifting device (large arrow above) when detaching Driver from Base Plate.

2. Disconnect drive cylinder to valve hose and drain fluid into a suitable container.
3. On Hydraulic Base Plate tighten Cylinder Stop Bolt and nut ('B' above).

4. Remove cotter pins and two (2) Base Plate Pins ('A' above) that connect the Base Plate to the Post Driver (applies to manual or hydraulic models).

NOTE: If necessary, lubricate channel mounting pins with penetrating oil to assist pin removal.

5. The upright assembly is heavy. Use an appropriate lifting device to position the Post Driver assembly horizontally, on suitable stands, pallet, or blocks on the ground.

Post Driver Disassembly

1. Remove Road Lock Pin and slide the Main Carriage Channel up as far as possible, to relieve tension on the Springs.
2. For HD-8/HD-10 Drivers connect retaining strap (A) to both Upper Spring eyes (B), with the strap positioned around the top of the Drive Ram Lift Yoke Bar (C) as shown below.

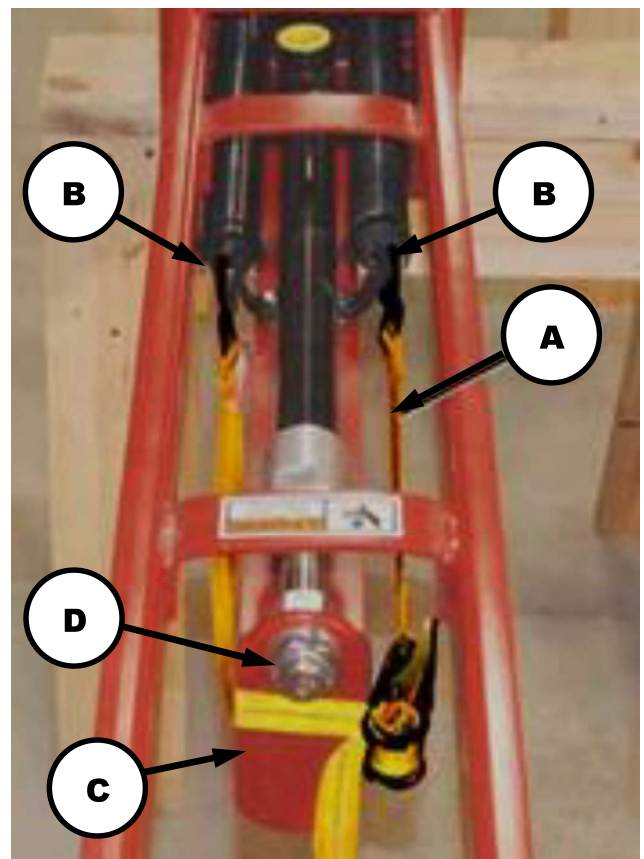

3. For HD-8/HD-10 use retaining strap to pull Springs up and off Upper Spring Bracket. Carefully loosen the retaining strap to release tension from the Springs.
4. For HD-12 carefully loosen and remove two upper return spring retaining bolts. **NOTE:**

There can be tension remaining on spring. As the bolt is removed, the spring will quickly retract (compress) away from upper spring bracket.

5. Remove the retaining strap (HD-8/HD-10) and remove the Upper Spring Bracket (HD-10/HD-12).
6. Remove the Upper Cylinder Rod Self-Locking Nut ('D' above) and lock washer from the Drive Cylinder Piston. **NOTE:** Do not reuse self-locking nut. Replace with a new self-locking nut.
7. For HD-8/HD-10 remove the two (2) self-locking nuts from Driver Cylinder and Lower Spring Bracket.
8. For HD-12 remove two lower spring bracket bolts, lock washers, and sleeves.
9. Slide the main carriage channel downward.
10. Remove the springs from the bottom of the Post Driver between the Drive Ram and the Main Carriage Channel.
11. Remove the Drive Cylinder by sliding it out the top of the Drive Ram Assembly.

NOTE: If Guide Blocks/Rollers need to be inspected and/or replaced continue with the next few steps, otherwise skip to the Seal and/or Spring replacement instructions.

12. Remove the Road Lock Bracket from the Main Carriage Channel.

CAUTION: Main Carriage Channel is heavy (HD-8 is 126 lbs., HD-10 is 139 lbs., & HD-12 is 222 lbs.), so get assistance and/or use an overhead lifting device to support it during removal.

13. Remove the Main Carriage Channel by sliding it out of the top of the Driving Ram.

- Drive Ram I-beam.
- Contact points on Guide Blocks/Rollers.
- Main Carriage Channel.
- Road Lock Bracket, Rubber Bumpers, and hardware.
- Springs, and Upper and Lower Spring Mounting Brackets.

Seal Replacement

NOTE: Follow the disassembly instructions for the Post Driver until the Cylinder is out of Driving Ram.

1. Unscrew the Cylinder Cap and remove the Cap and Piston Rod.

IMPORTANT: PLEASE TAKE CARE DURING REMOVAL OF PISTON ROD TO PREVENT SCORING IT, TO AVOID OIL LEAKAGE.

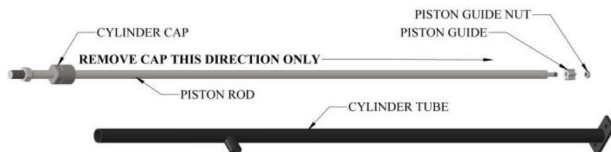

Driver Cylinder disassembly.

2. Remove the Piston Guide Nut and Piston Guide (SM-02610) from the lower end of Piston Rod. Slide the Cylinder Cap down and off the Piston Rod. **DO NOT** slide the Cylinder Cap up and off the Piston Rod as the upper threads will score the inside of the Cylinder Cap.
3. Use a screwdriver or pick to remove the old Seal (see below).

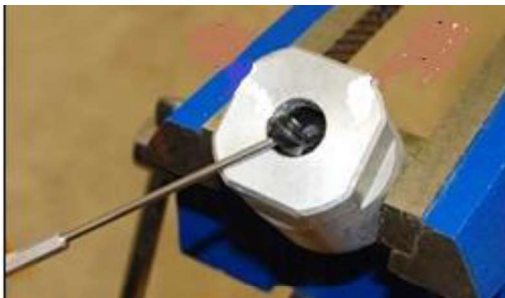

4. Clean the seal groove in Cylinder Cap.
5. Squeeze the new Seal together and place one end of it into the cavity of the Cap. Force the Seal down and it will snap into place. This is easier to do if the Seal has been softened by placing it in hot (120°F) water.
6. Oil the new Seal and slide the cylinder Cap onto the Piston Rod starting at the bottom. **DO NOT** slide the Cylinder Cap onto the Piston Rod from the top as the upper threads will score the inside of the Cylinder Cap and damage the new Seal.
7. Replace the Piston Guide and Piston Guide Nut.

8. Replace the Cylinder Cap & Piston Rod into the Cylinder Tube. Use a paste type thread sealer, **DO NOT USE A TAPE SEALER** as this will void the Cylinders warranty.
9. Replace the Cylinder into the Driving Ram and reassemble reversing the disassembly steps.
10. Adjust the locknuts to re-center the Cylinder.

Spring Replacement

CAUTION



Springs are UNDER TENSION when fastened. Move the Main Carriage Channel down to where the top of it is slightly past the top of the beam of the Driving Ram.

NOTE: Follow the disassembly instructions for the Post Driver until the Spring Assembly is out of Driving Ram.

HD-8 and HD-10 Springs.

1. Bend the Spring Clip back to their original shape as shown below. Insert a screwdriver through the loop and twist the Spring Clip out.

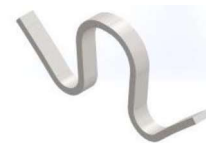

2. Force the screwdriver through the first coil of the new Spring and loop the Spring Clip into the Spring. Insert the screwdriver into the Clip, twist it into the replacement Spring at least two (2) coils down. Bend the ends of the Clips back to secure the replacement.
3. Reassemble new springs by reversing these steps.
4. Once installed and Driver is reassembled, run Driving Ram up and down 10 to 15 times without impact to season your Springs. Do this **EACH** time you start a new day.

HD-12 Springs.

NOTE: On an HD-12 Post Driver Spring replacement can be done without removing the Cylinder.

1. Remove the 1/2" bolt and lock washer from bottom of both springs.
2. Then remove the 1/2" bolt and lock washer from top of both springs.
3. Remove both Springs through the bottom of the Driving Ram.
4. Reassemble new springs by reversing these steps.
5. Once installed and Driver is reassembled, run Driving Ram up and down 10 to 15 times without impact to season your Springs. Do this EACH time you start a new day.

Guide Block/Roller Replacement

NOTE: Follow the disassembly instructions for the Post Driver until the Driving Ram is removed from the Driver.

1. Remove Guide Blocks/Rollers and Shims from pins inside the Drive Ram I-Beam.
IMPORTANT: Please take care to note the number and thickness of the shims, and the location of each shim pack removed. This information is needed for correct Drive Ram reassembly.
2. Install new Guide Blocks/Rollers with the Shims (the number and thickness noted above) at each pin location.

NOTE: Radius corners (rounded edges) on GuideBlocks/Rollers must be positioned into the channels to match the radius on the inside of the Main Carriage Channel Frame.

Post Driver Reassembly **Reverse the Post Driver Disassembly instruction.**

1. Lubricate the Guide Blocks with clean oil to reduce friction. Get assistance to slide Main Carriage Channel over Guide Blocks from the top of the Drive Ram.

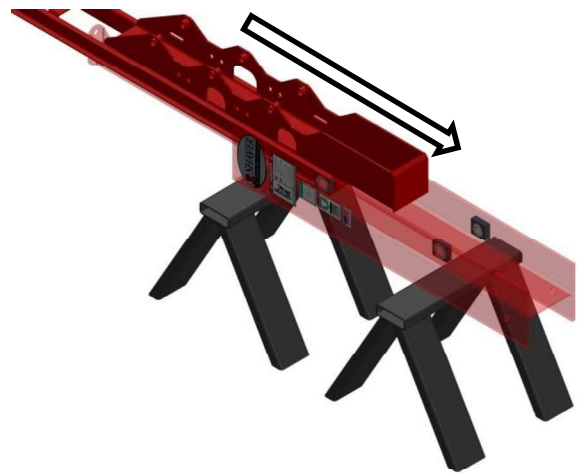

Main Carriage Channel assembly onto Guide Blocks and Driving Ram (shown above as transparent).

2. The Main Carriage Channel should slide back and forth freely.
3. With the Drive Ram Assembly horizontal, check the up and down, and side to side movement of the Main Carriage Channel in the Drive Ram I-Beam. Movement in either direction should not be more than 1/4".
NOTE: If movement is more than 1/4" then the Guide Blocks/Rollers will need to be shimmed to reduce this play under 1/4".
4. Install Drive Cylinder in Drive Ram Assembly from the top (upper end).

NOTE: Hydraulic Drive Ram Cylinder must be inserted in Main Carriage Channel before Springs are inserted. Position the Cylinder laying loose inside the Main Carriage Channel.

5. Install Springs from the bottom of the Post Driver between Drive Ram I-beam and Main Carriage Channel, and slide into position.
6. If removed, install two Rubber Bumpers on Road Lock Bracket. Install the Road Lock Bracket on Main Carriage Channel with bolts and nuts removed during **Post Driver Disassembly**. Leave nuts slightly loose.
7. Slide Main Carriage Channel up (forward) and install Lower Spring Bracket and Drive Cylinder Assembly onto Road Lock Bracket Bolts. Thread two new self-locking nuts onto the bolts. Install nuts just enough to fully engage threads.
8. For HD-12 attach the springs to the lower and upper spring brackets.
 - a. Install lower bolts, lock washers, and

Sleeves as shown below. Thread the bolts into Lower Spring Clip just enough to fully engage the boltthreads.

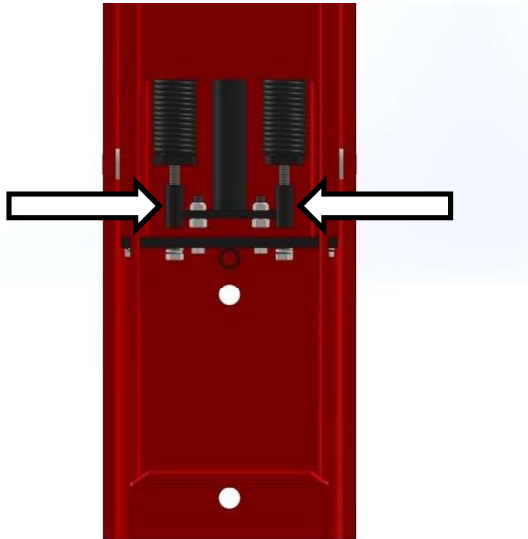

HD-12 lower spring bolts, lock washers, and sleeves (arrows).

- b. Position Upper Spring Bracket ('E' below) inside the Main Carriage Channel and slide it, under Drive Cylinder, up to the Upper Spring Clips ('F' below).

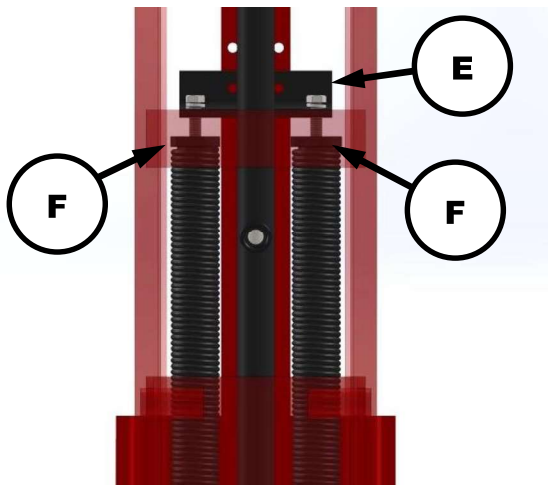

HD-12 Upper Spring Bracket. Return Spring. Upper Spring Bolt. Lock washer. (Main Carriage Channel shown transparent).

- c. Install upper spring bracket bolts and lock washers through Upper Spring Bracket ('E' above). Do not tighten the bolts. Thread the bolts into return Spring Upper Clips ('F' above) just enough to fully engage the threads.
9. Attach the Drive Cylinder Piston Rod to the top of the Drive Ram I-beam using new lock washer and new self-locking nut ('D' below)).

Tighten the nut just enough to fully engage the threads, as shown below.

10. HD-8/HD-10 attach Springs to Upper Spring Bracket. Hook (B) retaining strap (A) to Spring Clips and Route retaining strap around top of Drive Ram Lift Yoke Bar (C), as shown below.

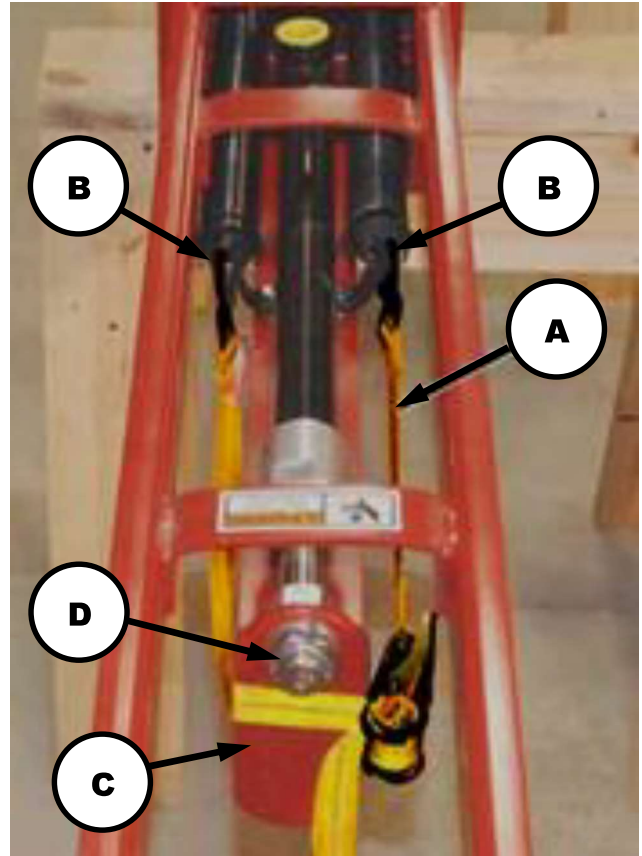

Upper Spring Bracket Bolts, Washers, and Nuts.

11. HD-10, install the Upper Spring Bracket on the Drive Ram Assembly.
 - a. Use the retaining strap to pull (stretch) the Springs ('B' above) just enough to align holes in Upper Spring Bracket and Drive Ram Assembly.
 - b. Install Upper Spring Bracket hardware and tighten securely.
 - c. Carefully release tension on the retaining strap and remove it from the Post Driver.
12. HD-12, attach the Upper Spring Bracket to the Drive Ram Yoke. The distance between the mounting holes in the Upper Spring Bracket and Drive Ram Yoke will be approximately two inches.

- a. Get assistance and use a suitable round pry bar to engage one set of holes in both the bracket and drive ram yoke. Pry the bracket forward until the second sets of holes are aligned.
- b. While holding the bracket in this position, secure the bracket using hardware (bolt, washer, lock washer, and nut) in the other hole, as shown.
- c. Remove the pry bar and install remaining upper bracket hardware (bolt, washer, lock washer, and nut). Tighten both the nuts securely.
- d. Completely tighten two upper spring mount bolts.
- e. Completely tighten lower spring mount bolts that were left loose in Step 8a.
- f. Tighten drive cylinder self-locking nuts that were left loose in Step 6. Tighten each nut slightly, in turn, to align the Drive Cylinder inside the Main Carriage Channel.

13. Align the Drive Ram Cylinder.

- a. Hold the lower nut with a 1-1/8" wrench and tighten self-locking nut (D) using a 1-1/16" wrench. Then loosen the self-locking nut 1/2 turn (180 degrees), as shown below.

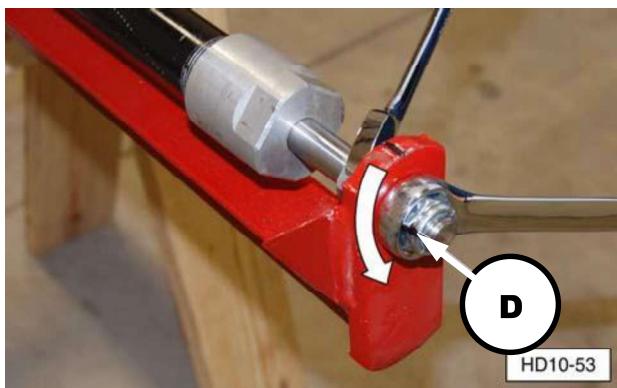

Drive Ram Cylinder and Self-locking Nut.

- b. Completely tighten road lock bracket nuts ('G' below where left loose in Step 6.
- c. Completely tighten self-locking nuts ('H' below) that were left loose in Step 7. Tighten each nut slightly, in turn, to align the Drive Cylinder inside the Main Carriage Channel.

- 14. Pull Main Carriage Channel down and install Road Lock Pin ('I' below) and Lynch Pin in upper hole in Drive Ram.**

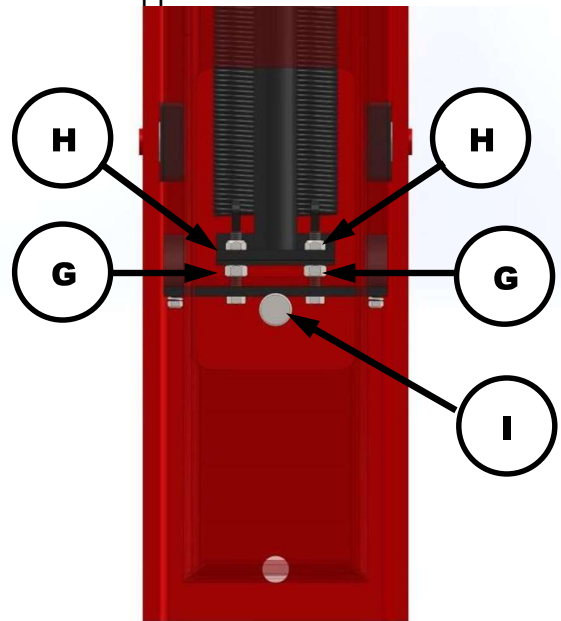

Lower Cylinder Mount, Road Lock Bracket and Lock Pin, HD-10 shown. (Main Carriage Channel shown transparent).

- 15. To avoid binding, the Drive Cylinder and Rod must be parallel to the sides of the Main Carriage Channel. If necessary, make the following adjustments:**
- a. Make sure the top Drive Ram Cylinder self-locking nut is loosened 1/2 turn.
 - b. Loosen Lower Drive Ram Cylinder self-locking nuts.
 - c. Tighten or loosen each nut slightly, in turn, to align the Drive Cylinder inside the Main Carriage Channel.

NOTE: Self-locking nuts do not have to be completely tightened against the Lower Spring Bracket.

Forward and Side Tilt Cylinder Seal Replacement

! WARNING



Removing tilt cylinder(s) from the assembled Post Driver can cause an unstable condition. To avoid personal injury or death, make sure the drive ram is fully supported by other means before removing the tilt cylinders for service.

1. When removing the cylinder(s) from the assembled Post Driver, make sure the drive ram is fully supported by other means, such as a suitable overhead lifting device
2. Make sure all tilt cylinder components are clean and free of rust.
3. Lubricate the new seals with clean hydraulic fluid.
4. Install new internal O-ring seals.

! WARNING



Make sure the snap ring is completely seated in the cylinder tube groove.

Failure to seat the snap ring in the groove can cause the cylinder cap to be explosively ejected from the tilt cylinder tube when hydraulic pressure is applied, resulting in serious injury or even death.

3-Point Hitch/Post Driver Assembly

1. With Road Lock Pin installed in the upper hole of Drive Ram, use a suitable overhead lifting device to raise (stand up) Main Carriage Channel Assembly.

! WARNING



The Main Carriage Channel Assembly is tall and heavy. To avoid tip over, resulting in serious injury or death, leave the overhead lifting device attached to the Main Carriage Channel while assembling components.



Overhead lifting device (arrow) Hydraulic Base Plate

2. For instructions on connecting the 3-Point Hitch Weldment and Post Driver Assembly after service, refer to Step 6 in the Assembly Procedure, Base Plate section of this manual.
3. Apply paste-type thread sealant to the pipe thread hose fitting. Connect drive cylinder hose to drive cylinder assembly. Tighten the hose fitting securely.

NOTE: Before using the Post Driver after service, it may be necessary to operate the

hydraulic control valve levers a few times, to remove air from the hydraulic system.

Storage

For best results, always store equipment in a dry, protected location. Leaving equipment unprotected will shorten the service life of the implement.

1. Before storing, remove debris and clean the entire unit with compressed air or pressure washer.
2. Inspect the Shaver Post Driver. Replace any worn or damaged parts before using the Post Driver again.
 - Check all bolted connections. Ensure that fasteners are tight, and all pins are secured in place.
 - Inspect frame for structural fractures.
 - Make sure all warning decals are in place and legible.
 - Make sure rubber debris guard is in place and in good condition.
 - Check hydraulic cylinder(s) for signs of seal damage or excessive wear.
 - Inspect all hydraulic hoses and fittings for leaks or signs of wear.
3. After cleaning, lightly lubricate guide blocks with clean engine oil. Do not apply grease, as this will retain grit and cause excessive wear.
4. Clean and lubricate hydraulic control valve safety stop linkage. Make sure return spring and cotter pins are in good condition.
5. Apply a light coating of clean grease to all exposed hydraulic cylinder shafts to help prevent rust.
6. On SHD-10 and HD-12-H-S Hydraulic Base Plate grease the two (2) lubrication fittings.

Troubleshooting

Troubleshooting Chart		
Problem	Possible Cause	Remedy
Drive Ram will not move or Slide freely in Main Carriage Channel.	<p>Guide Blocks/Rollers lack lubrication</p> <p>Guide Blocks/Rollers installed incorrectly.</p> <p>Incorrect clearance between Main Carriage Channel and Drive Ram I-Beam.</p> <p>Hydraulic Drive Cylinder Assembly is not parallel to Main Carriage Channel.</p> <p>Main Carriage Channel or Drive Ram is bent or damaged.</p>	<p>Lubricate with clean engine oil or spray lubricant.</p> <p>Refer to Service Information section assembly procedures for correct orientation.</p> <p>Refer to Service Information section for clearance specifications.</p> <p>Refer to Service Information section assembly Hydraulic Drive Cylinder installation and parallelism adjustment.</p> <p>Discontinue use and order replacement parts or buy new Driver.</p>
Poor performance, low or no impact, hydraulic drive cylinder will not extend.	<p>Weak or broken Drive Ram Springs.</p> <p>Broken Lower Spring Bracket.</p> <p>Bent or damaged Hydraulic Drive Cylinder Assembly.</p> <p>Main Carriage Channel is binding.</p> <p>Restricted or plugged hydraulic hoses.</p> <p>Low or no hydraulic pressure or flow from machine or power source.</p>	<p>Replace springs</p> <p>Replace Lower Spring Bracket.</p> <p>Replace or repair Hydraulic Drive Cylinder Assembly.</p> <p>Clean channels & lubricate blocks/rollers?</p> <p>Replace hydraulic hoses.</p> <p>Fill reservoir/tank with hydraulic fluid.</p>
Rubber Bumpers have premature or excessive damage.	Post Driver was not properly adjusted prior to operation and Drive Ram Guide Blocks/Rollers are contacting Rubber Bumpers.	Replace Rubber Bumpers and Adjust Post Driver.

NOTE: Refer to the Service Parts section of this manual for an illustration and description of all the parts.

Service Parts

Driver Assembly

SM-0011S-DRC - Ram Assembly, HD-8 Driver Stabilized

SM-1011S-DRC - Ram Assembly, HD-10 Driver Stabilized (SHOWN)

SM-1012S-DRC - Ram Assembly, SHD-10 Driver Springless

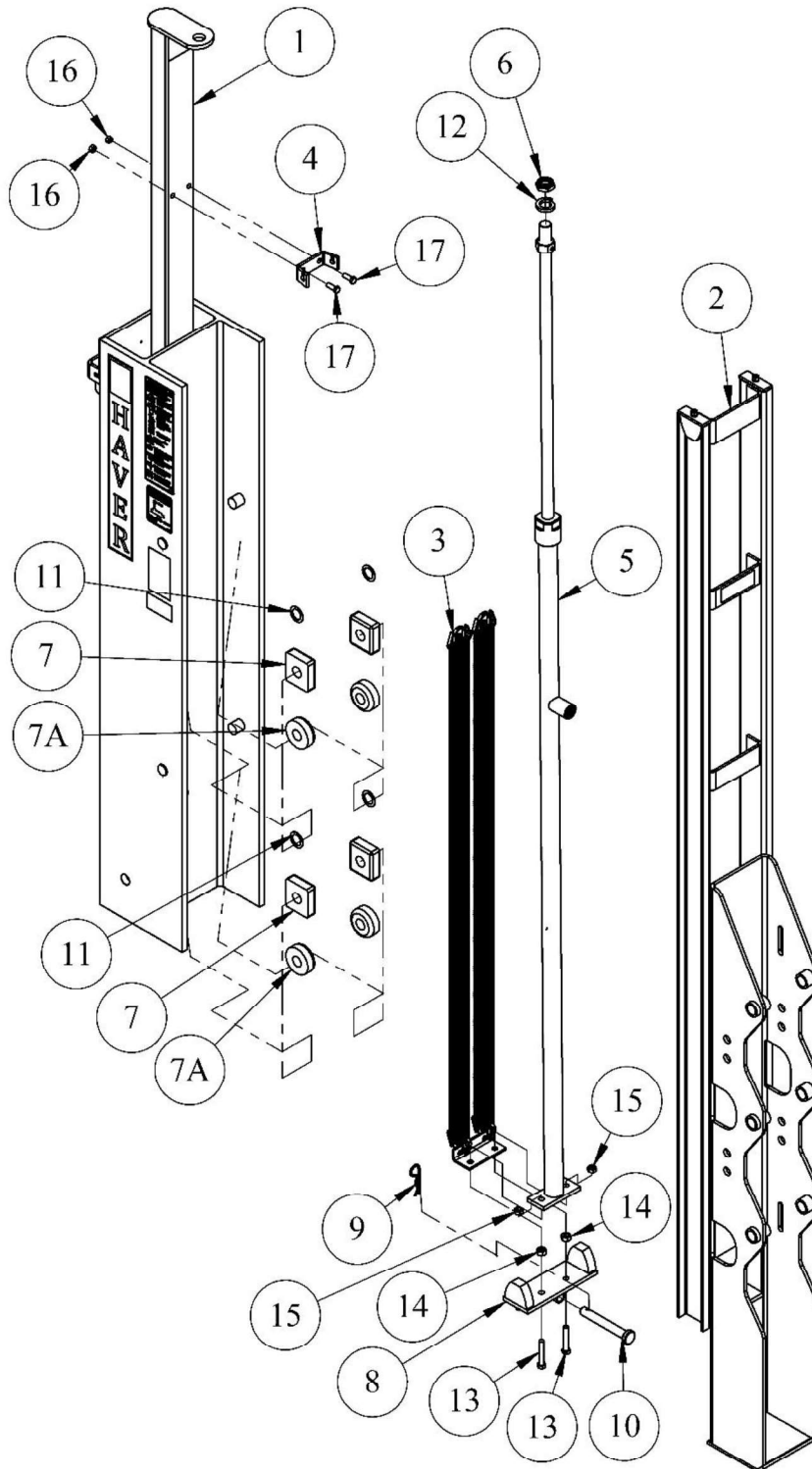

Driver Assembly

SM-0011S-DRC - Ram Assembly, HD-8 Driver Stabilized

SM-1011S-DRC - Ram Assembly, HD-10 Driver Stabilized (SHOWN)

SM-1012S-DRC - Ram Assembly, SHD-10 Driver Springless

Item	Qty. SM-0011S-DRC HD-8	Qty. SM-1011S-DRC HD-10 (Shown)	Qty. SM-1012S-DRC SHD-10 Springless	Part No.	Description
1	1	-	-	SM-0011-DRO	Ram Assembly, Driving, Only, HD-8
	-	1	-	SM-1011-DRO	Ram Assembly, Driving, Only, HD-10 (Shown)
	-	-	1	SM-1012-DRO	Ram Assembly, Driving, Only, SHD-10 Springless
2	1	-	-	SM-00412S	Carriage Assembly, HD-8 Stabilized
	-	1	1	SM-10412S	Carriage Assembly, HD-10 Stabilized (Shown)
3	1	-	NA	SM-0011-SA	Spring Assembly, HD-8
	-	1	NA	SM-1011-SA	Spring Assembly, HD-10 (Shown)
4	-	1	NA	SM-1011-SBU	Bracket, Upper, HD-10 Spring
5	1	-	-	SM-0263-S	Cylinder Assembly, Complete HD-8
	-	1	1	SM-1026-S	Cylinder Assembly, Complete HD-10/12 (Shown)
6	1	-	-	SM-0267	Locknut, Piston, HD-8
	-	1	1	SM-10267	Locknut, Piston, 1-8 Nylon (Shown)
7	4*	4*	6*	SM-00512R	Block, Nyrim
7A				SM-00510	Roller, UHMW, Driver
-	*	*	*	SM-00512	Nyrim Block – Pack of 4 (Not Shown)
				SM-00510-4	UHMW Rollers – Pack of 4 (Not Shown)
8	1	-	-	SM-0041-RLB	Bracket Assembly, Road Lock HD-8
	-	1	1	SM-1041-RLB	Plate Assembly, Road Lock HD-10 (Shown)
9	1	1	1	SM-1041-RLC	Clip, Road Lock
10	1	1	1	SM-1041-RLP	Pin, Road Lock
11	AR	AR	AR	SM-0933	Shim, 18 Ga. (.0478") Driver (Shown)
	AR	AR	AR	SM-0934	Shim, 14 Ga. (.0747") Driver
	AR	AR	AR	SM-0935	Shim, 10 Ga. (.1345") Driver
12	1	-	-	300166	Washer, Lock 3/4"
	-	1	1	300112	Washer, Lock 1"(Shown)
13	2	-	-	300194	Bolt, Tap 3/8-16 x 2 Hex Head Gr5 Zn
	-	2	2	300113	Bolt, Tap 7/16-14 x 2-1/2 Hex Head Gr5 Zn (Shown)
14	2	-	-	300180	Hex Nut, Heavy Pattern 3/8-16 Zn
	-	2	2	300115	Hex Nut, Heavy Pattern 7/16-14 Zn (Shown)
15	2	-	-	300181	Nut, Cone 3/8-16 Lock Zn
	-	2	2	300356	Nut, Cone 7/16-14 Lock Zn (Shown)
16	NA	2	NA	300181	Nut, Cone 3/8-16 Lock Zn
17	NA	2	NA	300189	Bolt, Tap 3/8-16 x 1 Hex Head Gr5 Zn

*When replacing Blocks/Rollers use all the same type.

Service Parts Driver Assembly

SM-1211S-DRC - Ram Assembly, HD-12 Driver Stabilized

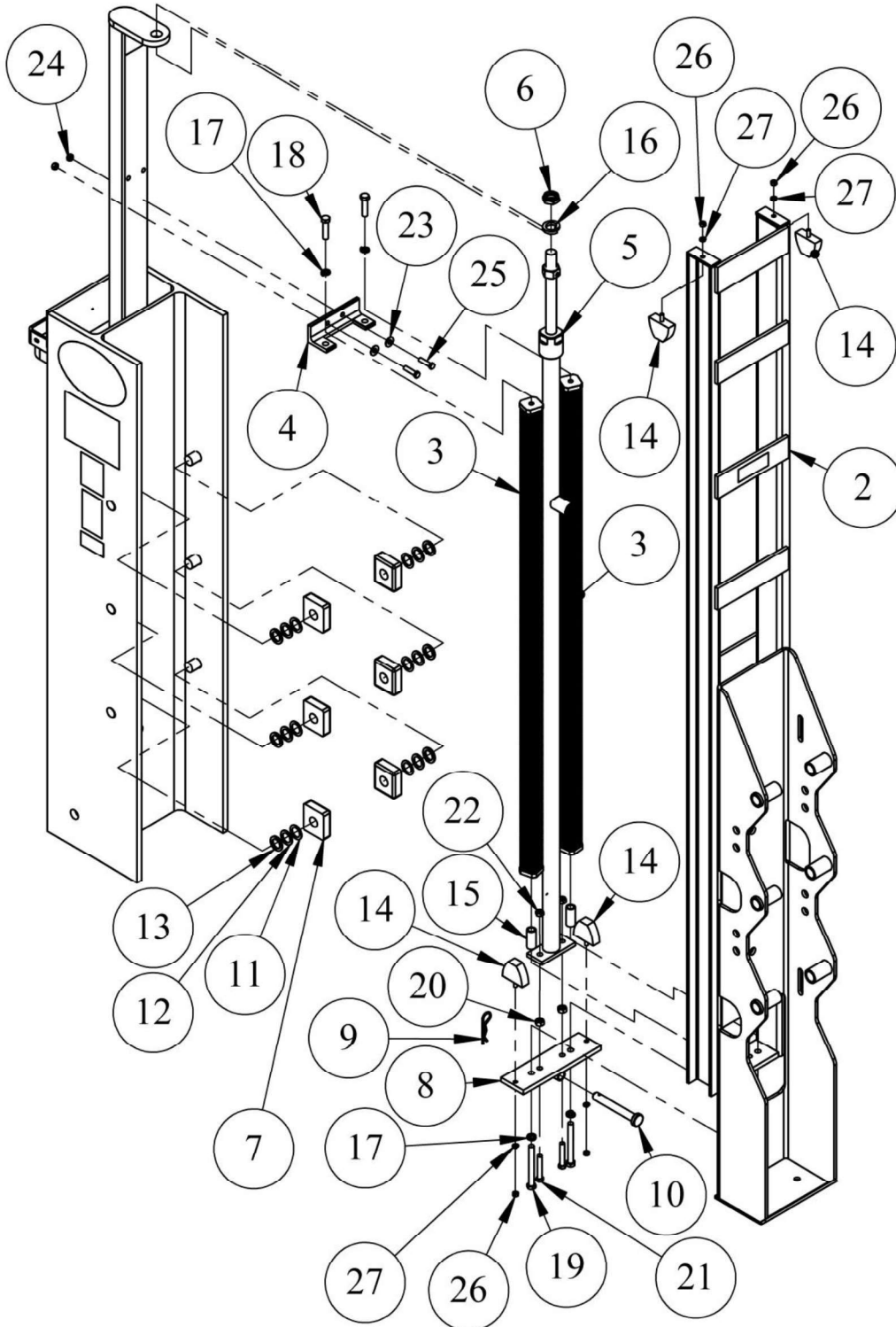

Driver Assembly

SM-1211S-DRC - Ram Assembly, HD-12 Driver Stabilize

Item	Qty.	Part No.	Description
1	1	SM-1211-DRO	Ram Assembly, Driving, Only, HD-12
2	1	SM-12412S	Carriage Assembly, HD-12 Stabilized
3	1	SM-1211-DRSA	Spring Assembly, HD-12
4	1	SM-1211-SBU	Bracket, Upper, HD-12 Spring
5	1	SM-1026-S	Cylinder Assembly, Complete HD-10/12
6	1	SM-10267	Locknut, Piston, 1-8 Nylon
7	6*	SM-00512R	Block, Nyrin
-	-	SM-00512	Nyrin Block – Pack of 4 (Not Shown)
8	1	SM-1241-RLBC	Bracket Weldment, Road Lock HD-12
9	1	SM-1041-RLC	Clip, Road Lock
10	1	SM-1041-RLP	Pin, Road Lock
11	AR	SM-0933	Shim, 18 Ga. (.0478") Driver
12	AR	SM-0934	Shim, 14 Ga. (.0747") Driver
13	AR	SM-0935	Shim, 10 Ga. (.1345") Driver
14	4	SM-0041-BR	Bumper, Rubber
15	2	SD-101-B2	Bushing, 1-7/8 OD x 5/8 ID x 2 L
16	1	300112	Washer, Lock 1" Zn
17	4	300101	Washer, Lock 1/2" Zn
18	2	300132	Screw, Cap 1/2-13 x 2 Hex Head Gr5 Zn Full Thread
19	2	300137	Bolt, Tap 1/2-13 x 4-1/2 Hex Head Gr5 Zn Full Thread
20	2	300115	Nut, Hex 7/16-14 Heavy Pattern Zn
21	2	300113	Bolt, Tap 7/16-14 x 2-1/2 Hex Head Gr5 Zn
22	2	300356	Nut, Cone 7/16-14 Lock Zn
23	2	300178	Washer, Flat 3/8" Zn
24	2	300181	Nut, Cone 3/8-16 Lock Zn
25	2	300184	Screw, Cap 3/8-16 x 1-1/2 Hex Head Gr5 Zn
26	4	300203	Nut, Hex 5/16-18 Zn
27	4	300204	Washer, Lock 5/16" Zn

Driver Assembly – Springs

SM-0011-SA - Spring Assembly, HD-8

SM-1011-SA - Spring Assembly, HD-10 (Shown)

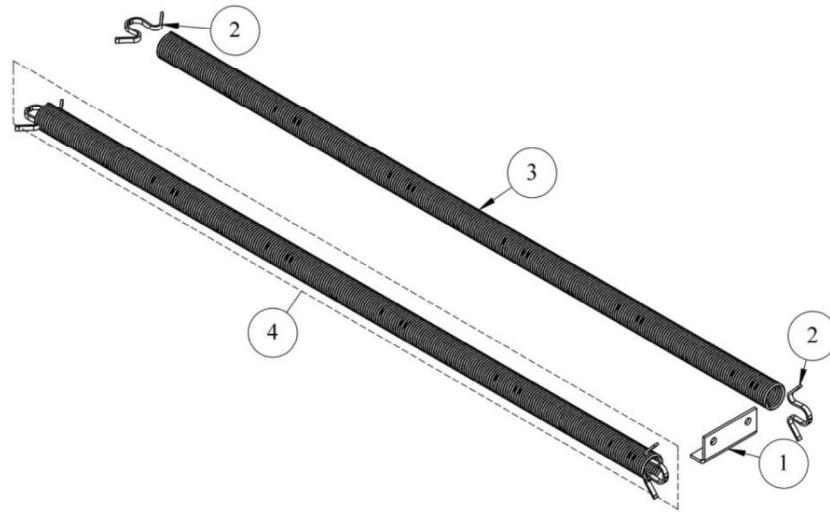

Item	Qty. SM-0263-S HD-8	Qty. SM-1011-SA HD-10	Part No.	Description
1	1	-	SM-0011-SBL	Bracket, Lower Spring, HD-8
	-	1	SM-1011-SBL	Bracket, Lower Spring, HD-10 (Shown)
2	4	-	SM-0011-SC	Clip, Spring, HD-8
	-	4	SM-1011-SC	Clip, Spring, HD-10 (Shown)
3	2	-	SM-0011-DRSO	Spring, Driving Ram Only, HD-8
	-	2	SM-1011-DRSO	Spring, Driving Ram Only, HD-10 (Shown)
4	*	-	SM-0011-DRS	HD-8 Driving Ram Spring Complete
	-	*	SM-1011-DRS	HD-10 Driving Ram Spring Complete (Shown)

* Includes two (2) Item #2's & one (1) Item #3

Driver Assembly – HD-12 Springs

SM-1211-DRS - Spring Assembly, HD-12

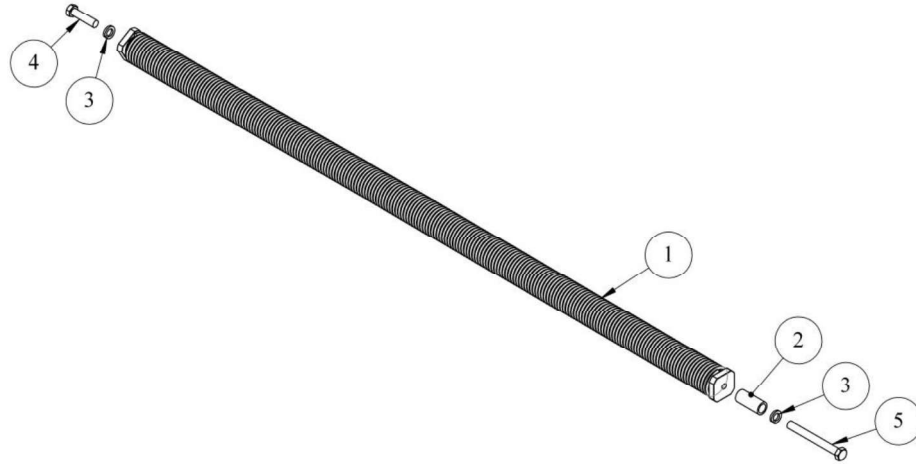

Item	Qty.	Part No.	Description
1	1	SM-1211-DRSA	Spring Assembly, HD-12
2	1	SD-101-B2	Bushing, 1-7/8 OD x 5/8 ID x 2 L
3	2	300101	Washer, Lock 1/2" Zn
4	1	300132	Screw, Cap 1/2-13 x 2 Hex Head Gr5 Zn Full Thread
5	1	300137	Bolt, Tap 1/2-13 x 4-1/2 Hex Head Gr5 Zn Full Thread

SM-1211-DRSA - Spring Assembly, HD-12

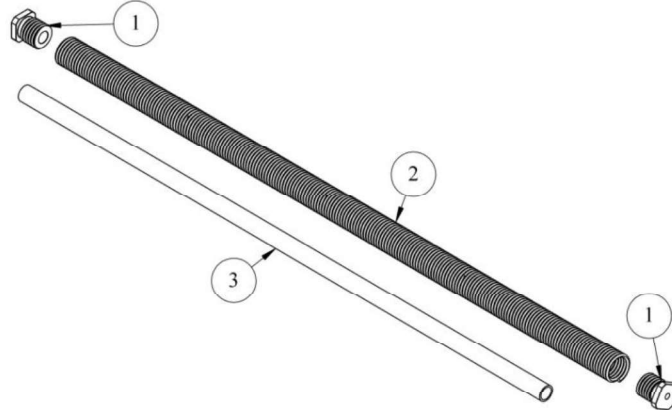

Item	Qty.	Part No.	Description
1	2	SM-1211-SC	Clip, Spring, HD-12
2	1	SM-1211-DRSO	Spring, HD-12 Driving Ram Only
3	4ft. 2in.	300249	Tube, Clear Vinyl 1" ID x 1.25" OD

Driver Assembly – HD-12 Springs

SM-1211-SBU – Upper Spring Bracket, HD-12

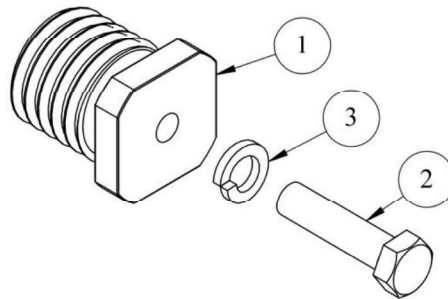

Item	Qty.	Part No.	Description
1	1	SM-1211-SC	Clip, Spring, HD-12
2	1	300101	Washer, Lock 1/2" Zn
3	1	300132	Screw, Cap 1/2-13 x 2 Hex Head Gr5 Zn Full Thread

SM-1211-SBL – Lower Spring Bracket, HD-12

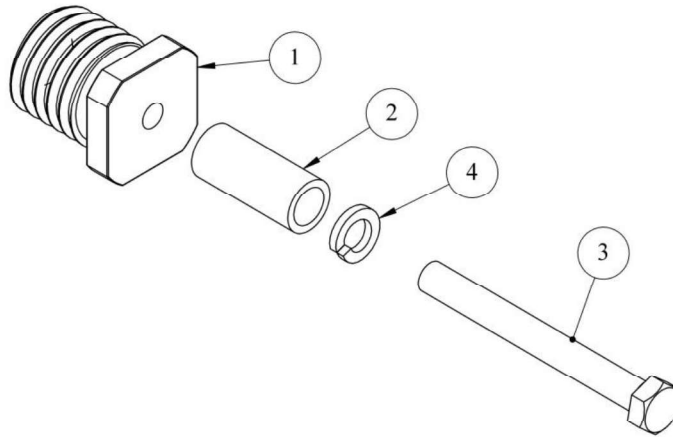

Item	Qty.	Part No.	Description
1	1	SM-1211-SC	Clip, Spring, HD-12
2	1	SM-1211-SCB	Bushing, Spring Clip, HD-12
3	1	300101	Washer, Lock 1/2" Zn
4	1	300137	Bolt, Tap 1/2-13 x 4-1/2 Hex Head Gr5 Zn Full Thread

Driver Assembly – Road Lock Plate Assemblies & Cushions

SM-0041-RLB – Plate Assembly, Road Lock, HD-8

SM-1041-RLB – Plate Assembly, Road Lock, HD-10 (Shown) & SHD-10

SM-1241-RLB – Plate Assembly, Road Lock, HD-12

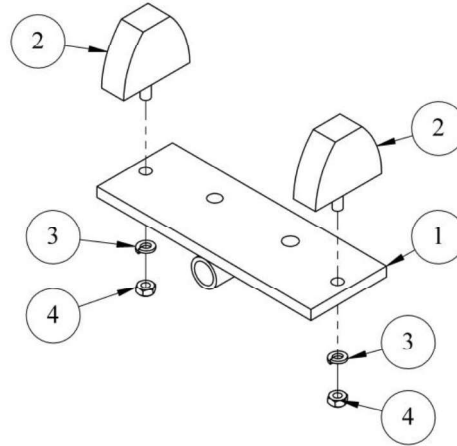

Item	Qty. SM-0041-RLB HD-8	Qty. SM-1041-RLB HD-10 (Shown) & SHD-10	Qty. SM-1241-RLB HD-12	Part No.	Description
1	1	-	-	SM-0041-RL	Plate Weldment, Road Lock, HD-8
	-	1	-	SM-1041-RLBPW	Plate Weldment, Road Lock, HD-10 (Shown) & SHD-10
	-	-	1	SM-1241-RLBC	Bracket Weldment, Road Lock HD-12
2	2	2	2	SM-0041-BR	Bumper, Rubber
3	2	2	2	300203	Nut, Hex 5/16-18 Zn
4	2	2	2	300204	Washer, Lock 5/16" Zn

SM-00412S – Carriage Assembly, HD-8 Stabilized

SM-10412S – Carriage Assembly, HD-10 Stabilized (Shown) & SHD-10

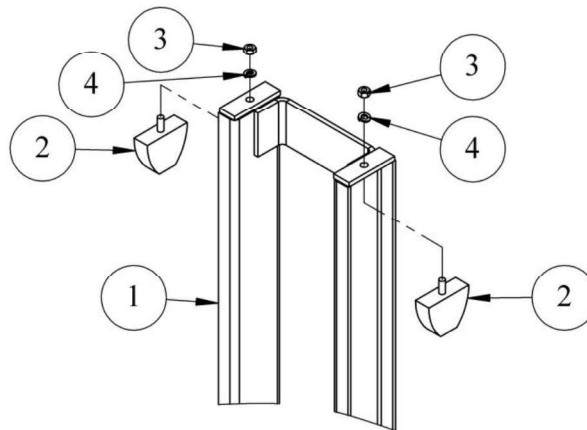

Item	Qty. SM-00412S HD-8	Qty. SM-10412S HD-10 (Shown) & SHD-10	Part No.	Description
1	1	-	SM-00413S	Carriage Weldment, HD-8 Main
	-	1	SM-10413S	Carriage Weldment, HD-10 Main (Shown) & SHD-10
2	2	2	SM-0041-BR	Bumper, Rubber
3	2	2	300203	Nut, Hex 5/16-18 Zn
	2	2	300204	Washer, Lock 5/16" Zn

Rubber Guard Assembly
SM-1211-G – Rubber Guard Kit HD-8/10/12

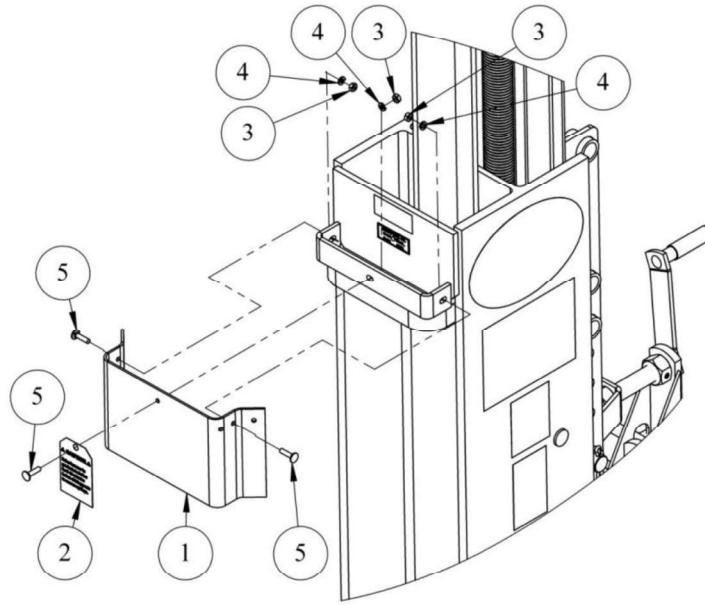

Item	Qty.	Part No.	Description
1	1	SM-1211-G3	Shield, Rubber 6" x 14-3/4"
2	1	SM-0011-ST	Tag, Caution Springs
3	3	300145	Nut, Hex 1/4-20 Zn
4	3	300147	Washer, Lock 1/4 Zn
5	3	300149	Bolt, Carriage 1/4-20 x 1 Gr2 Zn

SM-1212-GS – Rubber Guard Kit Springless (for SHD-10)

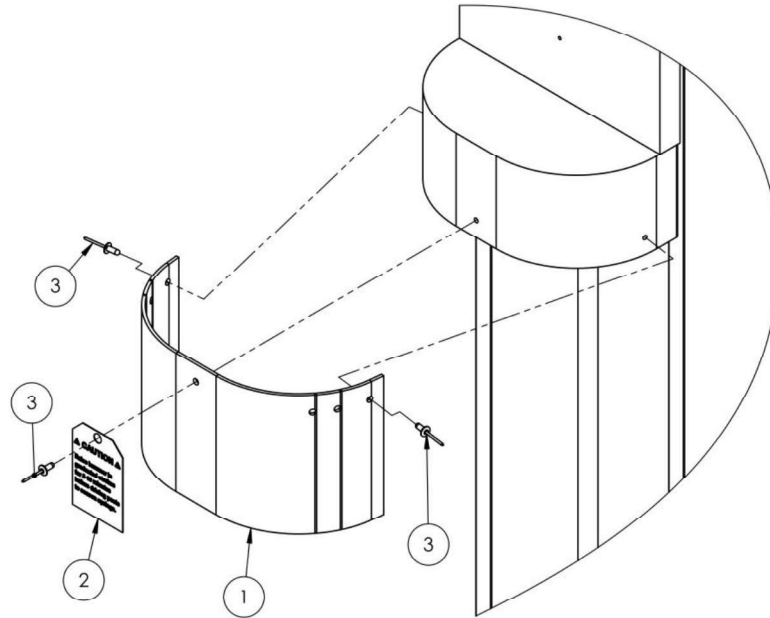

Item	Qty.	Part No.	Description
1	1	SM-1211-G3	Shield, Rubber 6" x 14-3/4"
2	1	SM-0011-ST	Tag, Caution Springs
3	3	300360	Rivet, 3/16" x 3/8"

Safety Arm Assembly

SM-0011-SAA - Safety Arm Assembly

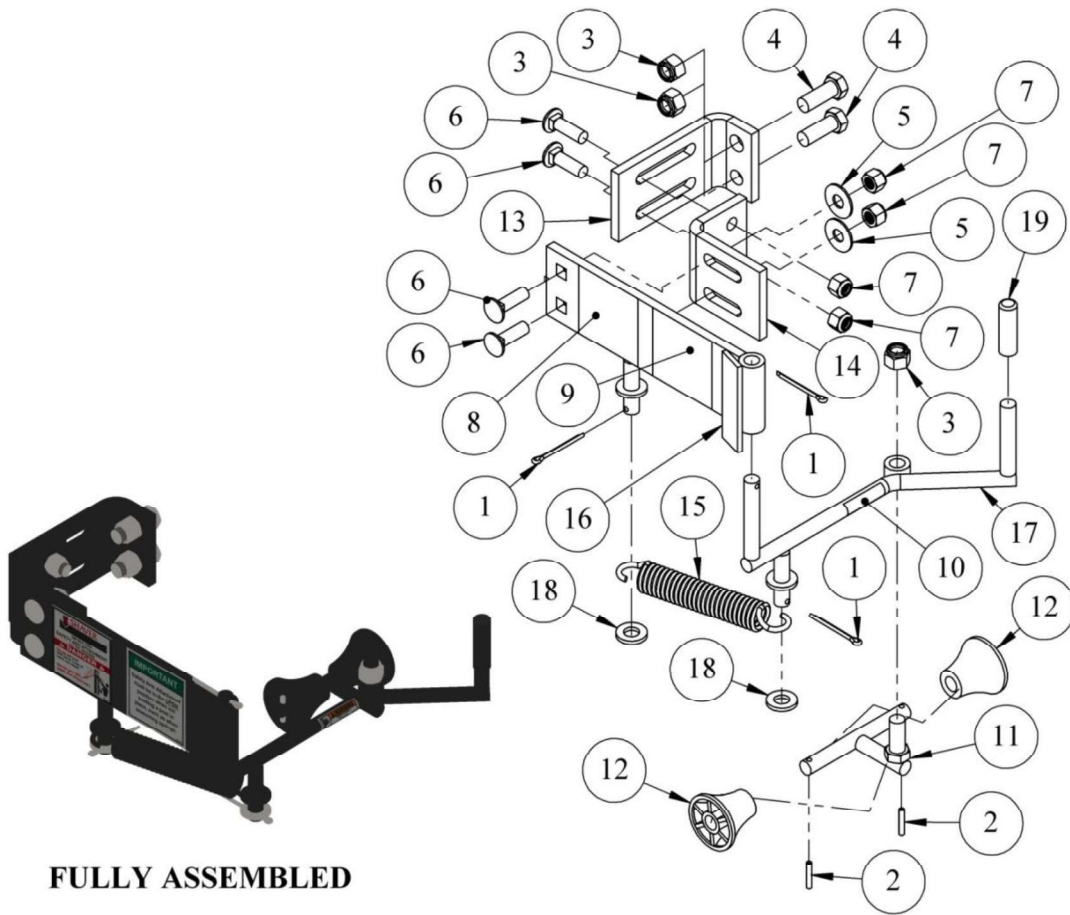

Item	Qty.	Part No.	Description
1	3	300106	Pin, Cotter 3/16 x 2-1/2
2	2	300148	Pin, Roll 1/4 x 1-1/2
3	3	300167	Nut, Lock 3/4-10 Nylon Hex Zn
4	2	300172	Bolt, Tap 3/4-10 x 2 Hex Head Gr5 Zn
5	2	300213	Washer, Flat 5/8
6	4	300221	Bolt, Carriage 5/8-11 x 2 Gr5 Zn
7	4	300359	Locknut, 5/8-11 Hex Nylock Zn
8	1	MS-165	Decal, Danger Safety Arm Attachment
9	1	MS-166	Decal, Important Leave Arm Open
10	1	MS-181	Decal, Warning Pinch Point
11	1	SM-0011-SAA13W	Holder Weldment, Roller
12	2	SM-0011-SAA16	Roller
13	1	SM-0011-SAA17	Angle, Adjustable Mount, Driver
14	1	SM-0011-SAA18	Angle, Adjustable Mount, Arm
15	1	SM-0011-SAA2	Spring, Latch
16	2	SM-0011-SAABW	Bar Weldment, Safety Arm
17	1	SM-0011-SAAD	Arm Weldment, Swing Handle
18	2	SM-0011-SAAF	Washer, Flat 3/4 Double Thick
19	1	SM-015-CC	Crank, Cover

Manual Base Plate Assembly

HD-8 & HD-10 Manual Base Plate

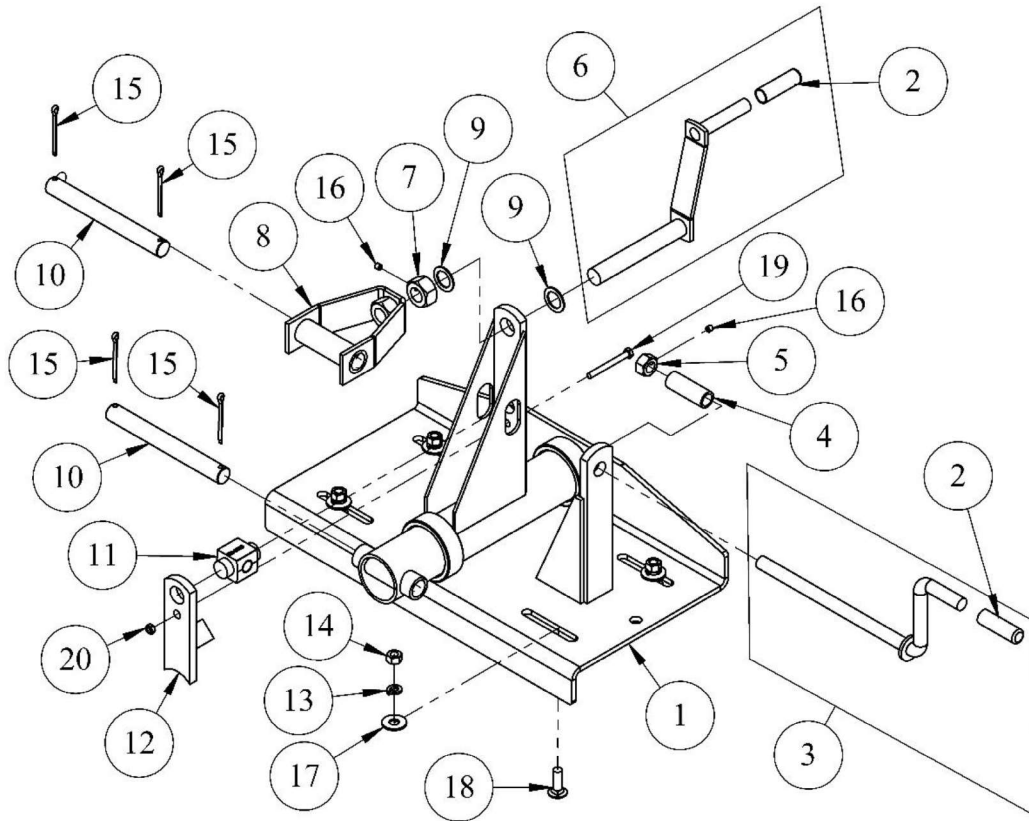

Item	Qty.	Part No.	Description
1	1	SM-1015	Base-Plate Weldment, HD-10
2	2	SM-015-CC	Cover, Crank, HD-8/10
3	1	SM-016	Crank Assembly, Side Tilt (includes SM-015-CC)
4	1	SM-017	Sleeve, Side Tilt Crank
5	1	SM-018	Nut, 3/4-10 Side Tilt Crank
6	1	SM-019	Crank Assembly, End Tilt (includes SM-015-CC)
7	1	SM-021	Nut, 1-8 End Tilt Crank
8	2	SM-022	Tee, End Tilt Crank
9	2	SM-0934	Shim, 14 Ga. (.0747") Driver
10	2	SM-1007	Pin, Stabilizer Base Plate HD-10
11	1	SM-2025-SBM	Block, Screw, Machined
12	1	SM-2025-SBS	Support, Screw Block
13	4	300216	Washer, Lock 5/8" Zn
14	4	300107	Nut, Hex 5/8-11 Zn
15	4	300106	Pin, Cotter 3/16 x 2-1/2 Zn
16	2	300111	Screw, HSSS 5/16-18 x 5/16
17	4	300213	Washer, Flat 5/8 Zn
18	4	300221	Bolt, Carriage 5/8-11 x 2 Gr5 Zn
19	1	300210	Bolt, HHCS 5/16-18 x 3 Gr5 Zn
20	1	300254	Nut, Lock 5/16-18 Cone Hex Zn

Hydraulic Base Plate Assembly

HD-8 & HD-10 Hydraulic Base Plate

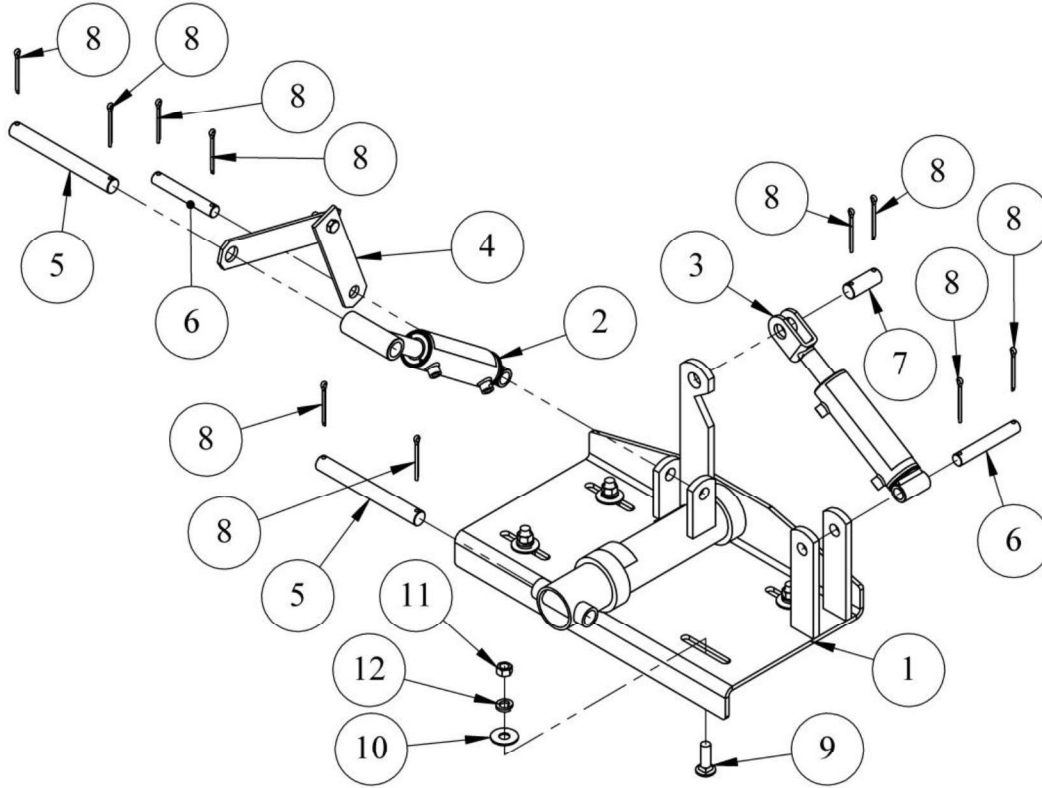

Item	Qty.	Part No.	Description
	*	HBP-91011	HD-10 Hydraulic Base Plate Assembly (Includes mounting hardware)
1	1	HBP-91012	Plate Weldment, Base, Hyd.
2	1	HBP-90296	Cylinder, Hyd. Forward Tilt
-	-	HBP-90296-SK	Seal Kit, 2" Tilt Cylinder (Not Shown)
3	1	HBP-90297	Cylinder, Hyd. Side Tilt
-	-	HBP-90296-SK	Seal Kit, 2" Tilt Cylinder (Not Shown)
4	1	HBP-908-CS	Stop Assembly, Scissor
5	2	SM-1007	Pin, Stabilizer Base Plate HD-10
6	2	HBP-908133	Pin, Cylinder, 13/16" Dia. x 5-1/4"
7	1	HBP-908134	Pin, Cylinder, 1" Dia. x 2-1/2"
8	10	300106	Pin, Cotter 3/16 x 2-1/2 Zn
9	4	300221	Bolt, Carriage 5/8-11 x 2 Gr5 Zn
10	4	300213	Washer, Flat 5/8 Zn
11	4	300107	Nut, Hex 5/8-11 Zn
12	4	300216	Washer, Lock 5/8" Zn

Hydraulic Base Plate Assembly

HD-12 & SHD-10 Hydraulic Base Plate

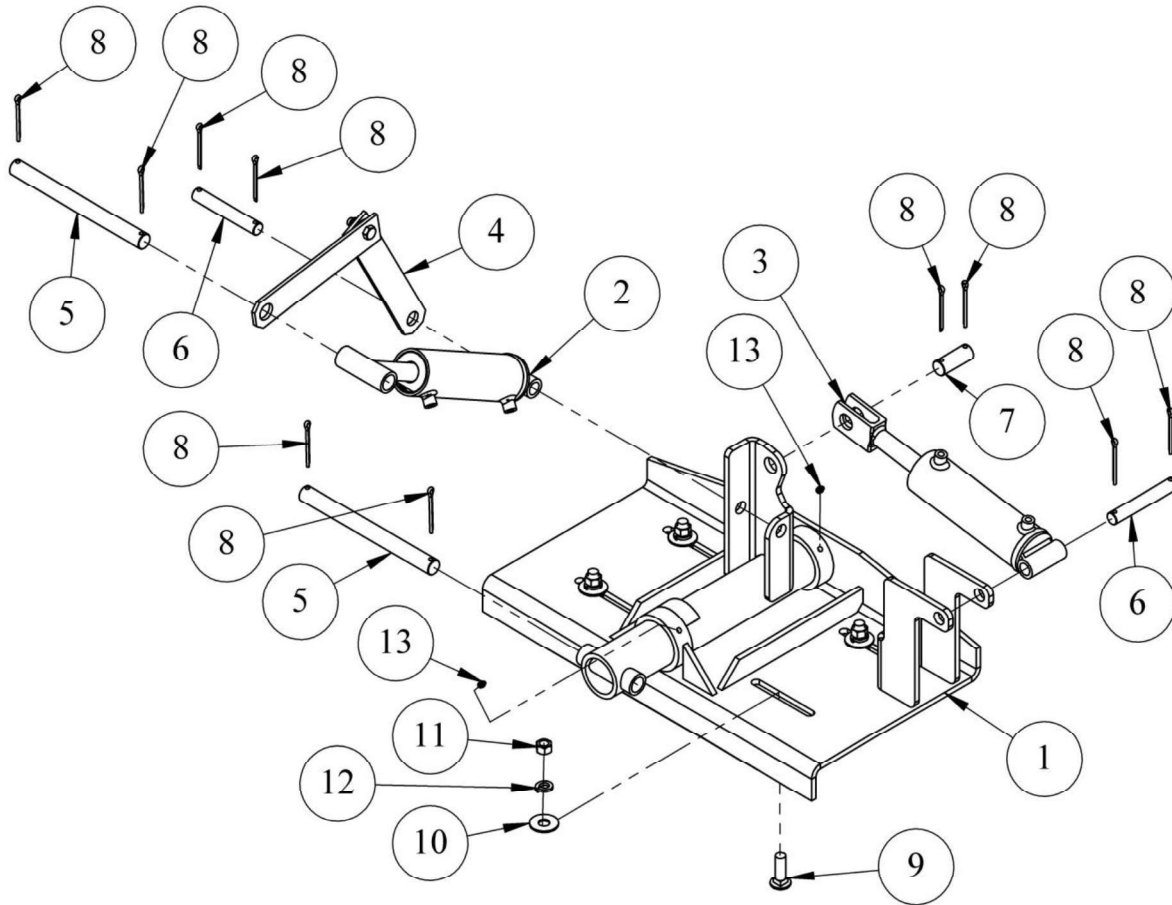

Item	Qty.	Part No.	Description
-	-	HBP-912111	HD-12 Hydraulic Base Plate Assembly (Includes mounting hardware)
1	1	HBP-912115	Plate Weldment, Base, Hyd. HD-10
2	1	HBP-91217	Cylinder, Hyd. Forward Tilt
-	-	HBP-912177	Seal Kit, 2-1/2" Tilt Cylinder (Not Shown)
3	1	HBP-91218	Cylinder, Hyd. Side Tilt
-	-	HBP-912177	Seal Kit, 2-1/2" Tilt Cylinder (Not Shown)
4	1	HBP-9012-6	Stop Assembly, Scissor
5	2	SM-1207	Pin, Stabilizer Base Plate HD-12
6	2	HBP-908133	Pin, Cylinder, 13/16" Dia. x 5-1/4"
7	1	HBP-908134	Pin, Cylinder, 1" Dia. x 2-1/2"
8	10	300106	Pin, Cotter 3/16 x 2-1/2 Zn
9	4	300221	Bolt, Carriage 5/8-11 x 2 Gr5 Zn
10	4	300213	Washer, Flat 5/8 Zn
11	4	300107	Nut, Hex 5/8-11 Zn
12	4	300216	Washer, Lock 5/8" Zn
13	2	300346	Fitting, Grease Straight 5/16 Drive

Manual Base Plate Valve & Hose Assembly

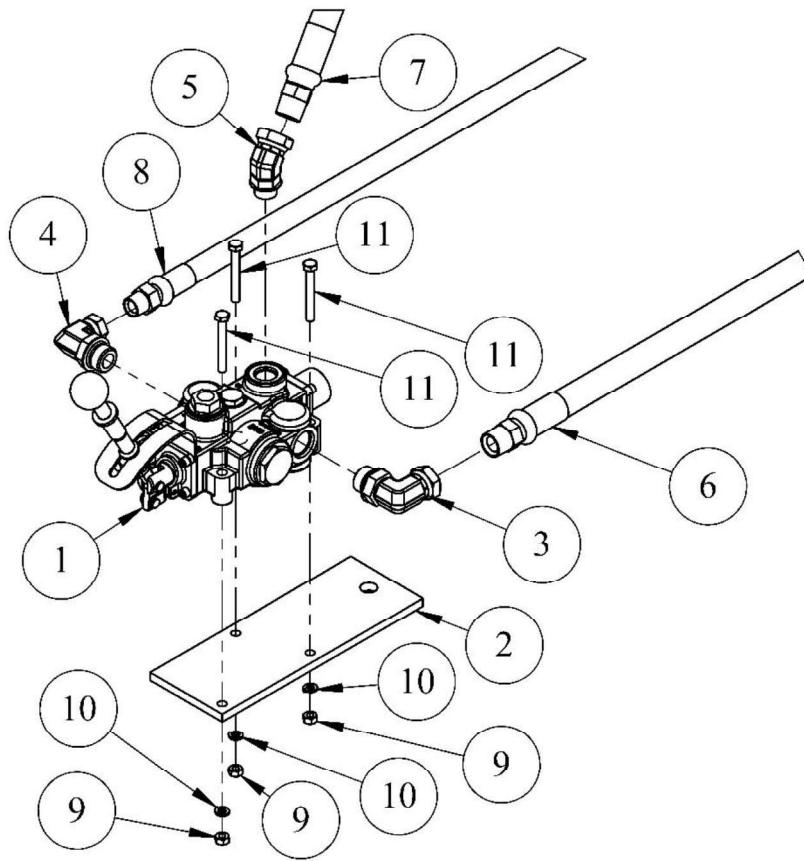

Item	Qty.	Part No.	Description
1	1	VP-01-SP	Valve – 1 Spool
2	1	SM-001-PVBP	Plate, Prince Valve Bracket
3	1	SC-50-H52	Adapter, 90° SAE #12MORB – 3/4FNPT
4	1	CTP-69011208	Adapter, 90° SAE #12MORB – 1/2NPTSM
5	1	F-6902-10-12	Adapter, 45° SAE #10MORB – 3/4FNPT
6	1	SM-025-R	Hose Assembly, Hyd. 3/4 x 120"
7	1	SM-0252-R	Hose Assembly, Hyd. 3/4 x 48"
8	1	SM-0234-P	Hose Assembly, Hyd. 1/2 x 120 8MXMS 100R2
9	3	300203	Nut, Hex 5/16-18 Zn
10	3	300204	Washer, Lock 5/16 Zn
11	3	300207	Bolt, HHCS 5/16-18 x 2-1/2 Gr5 Zn

Hydraulic Base Plate Valve & Hose Assembly

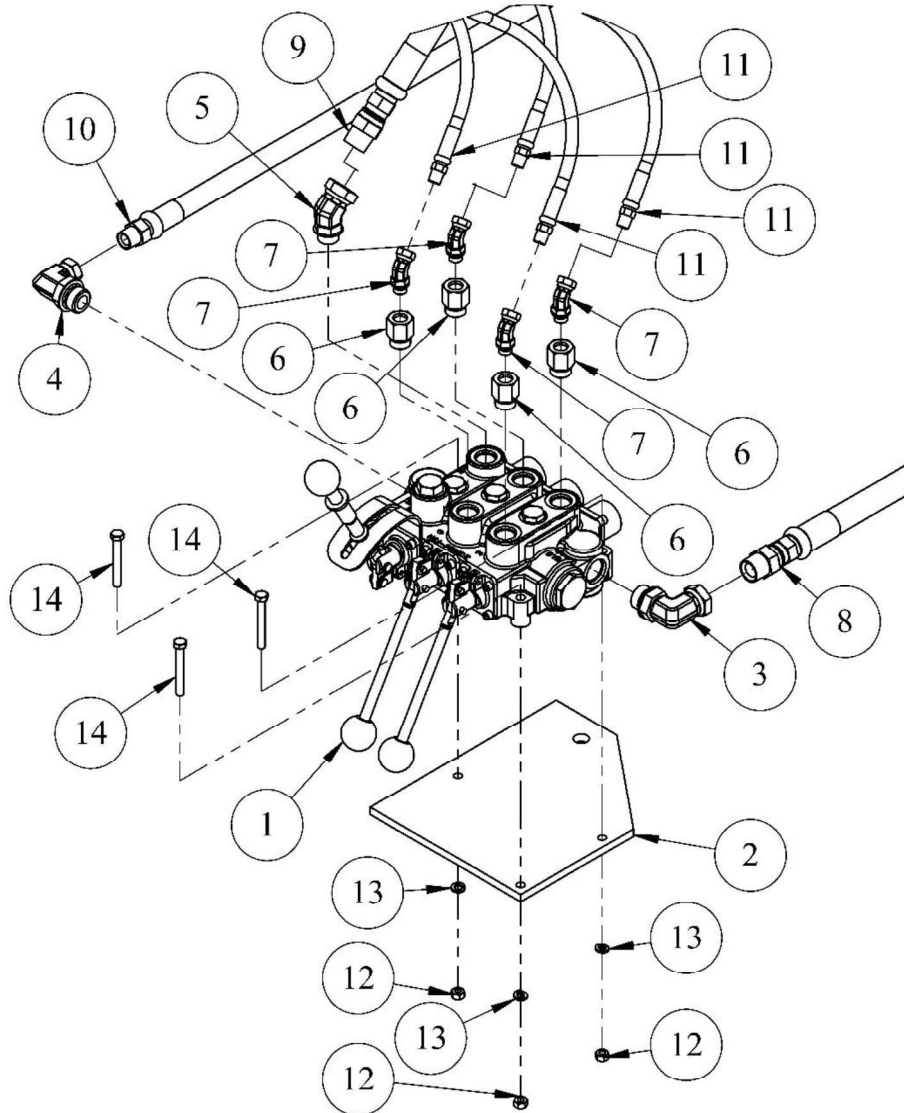

Item	Qty.	Part No.	Description
1	1	VP-03-SP	Valve – 3 Spool
2	1	SM-003-PVBP	Plate, Valve Bracket V-03
3	1	SC-50-H52	Adapter, 90° SAE #12MORB – 3/4FNPT
4	1	CTP-69011208	Adapter, 90° SAE #12MORB – 1/2NPTSM
5	1	F-6902-10-12	Adapter, 45° SAE #10MORB – 3/4FNPT
6	4	F-6410-10-06	Adapter, Straight SAE #10MORB – #6FORB
7	4	F-6902R-6-4-.03	Adapter, 45° SAE #6MORB – 1/4FNPT
8	1	SM-025-R	Hose Assembly, Hyd. 3/4 x 120"
9	1	SM-0252-R	Hose Assembly, Hyd. 3/4 x 48"
10	1	SM-0234-P	Hose Assembly, Hyd. 1/2 x 120 8MXMS 100R2
11	4	SM-02111-P	Hose Assembly, Hyd. 1/4 x 26"
12	3	300203	Nut, Hex 5/16-18 Zn
13	3	300204	Washer, Lock 5/16 Zn
14	3	300207	Bolt, HHCS 5/16-18 x 2-1/2 Gr5 Zn

3-Point Hitch Assembly

MB-01-A - Bracket Assembly, CAT-I & II 3-Point Mounting w/Stands

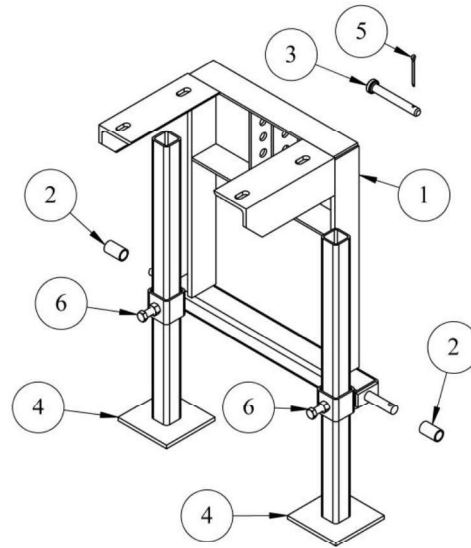

Item	Qty	Part No.	Description
1	1	MB-01-AA	Bracket Weldment, 3-Point Mounting CAT-3
2	2	MB-01A-12	Bushing (for CAT-II)
3	1	SM-1041-RLP	Pin, Road Lock (included in MB-01-AA)
4	2	OS-4-22SFA	Leg Weldment, Storage
5	1	300106	Pin, Cotter 3/16 x 2-1/2 (included in MB-01-AA)
6	2	300218	Screw, Cap 5/8-11 x 1-3/4 Hex Head Gr5 Zn (included in MB-01-AA)

MB-1201-A - Bracket Assembly, CAT-II 3-Point Mounting w/Stands (HD-10/HD-12/SHD-10)

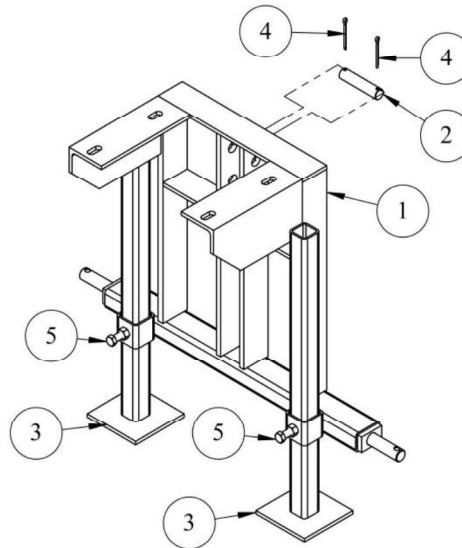

Item	Qty	Part No.	Description
1	1	MB-1201-AA	Bracket Weldment., 3-Point Mounting CAT-2
2	1	MB-1201A-12	Pin, Top 3-Point
3	2	OS-4-22SFA	Leg Weldment, Storage
4	2	300106	Pin, Cotter 3/16 x 2-1/2
5	2	300218	Screw, Cap 5/8-11 x 1-3/4 Hex Head Gr5 Zn (included in MB-1201-AA)

3-Point Hitch Assembly

MB-1301-A - Bracket Assembly, CAT-III 3-Point Mounting w/Stands (HD-10/HD-12/SHD-10)

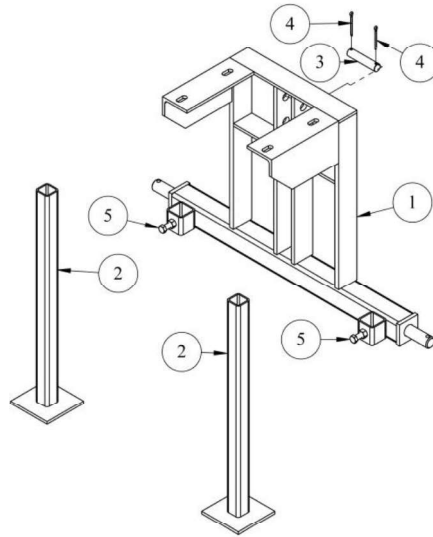

Item	Qty	Part No.	Description
1	1	MB-1301-AA	Bracket Weldment, 3-Point Mounting CAT-3
2	2	OS-4-22SFA	Leg Weldment, Storage Stand
3	1	MB-1201A-12	Pin, Top 3-Point
4	2	300106	Pin, Cotter 3/16 x 2-1/2
5	2	300218	Screw, Cap 5/8-11 x 1-3/4 Hex Head Gr5 Zn (included in MB-1301-AA)

OS-4-22 - Stand Package, Manual (Old Style)

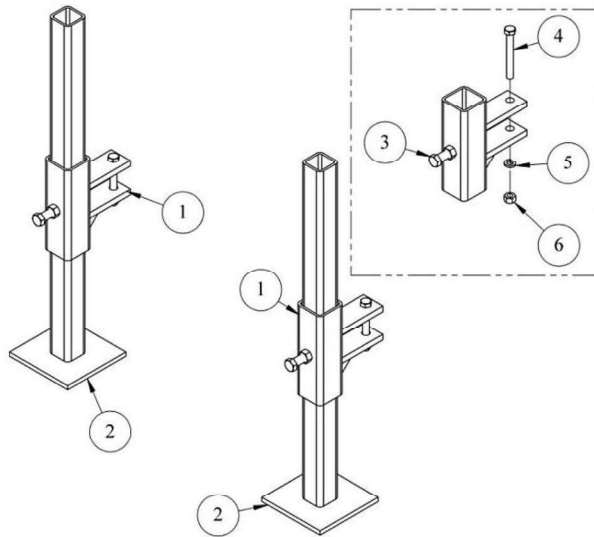

Item	Qty	Part No.	Description
1	1	OS-4-22SFBA	Bracket Weldment, Storage Stand
2	2	OS-4-22SFA	Leg Weldment, Storage Stand
3	2	300218	Screw, Cap 5/8-11 x 1-3/4 Hex Head Gr5 Zn (included in OS-4-22SFBA)
4	2	300138	Screw, Cap 1/2-13 x 4 Hex Head Gr5 Zn (included in OS-4-22SFBA)
5	2	300101	Washer, Lock 1/2 Zn (included in OS-4-22SFBA)
6	2	300102	Nut, Hex 1/2-13 Zn (included in OS-4-22SFBA)

Skid Steer/Loader Mounting Assembly

MBS-77-10 - Bracket Assembly, Universal Mounting

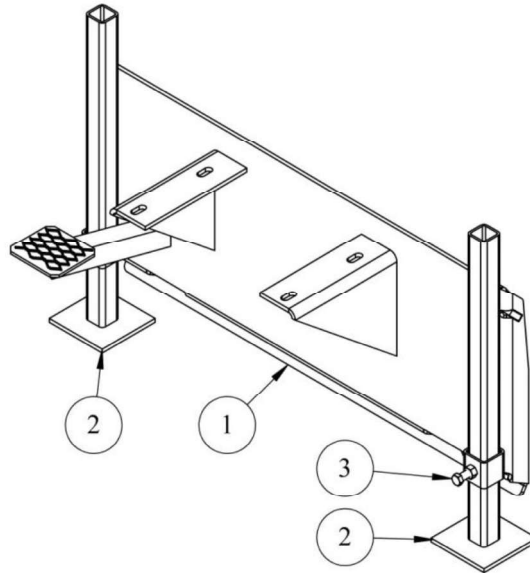

Item	Qty	Part No.	Description
1	1	MBS-77-10AA	Bracket Weldment., Driver Skid Loader
2	2	OS-4-22SFA	Leg Weldment, Storage Stand
3	2	300218	Screw, Cap 5/8-11 x 1-3/4 Hex Head Gr5 Zn (included in MBS-77-20AA)

MBS-77-20 - Bracket Assembly, Universal Mounting (for OH-200)

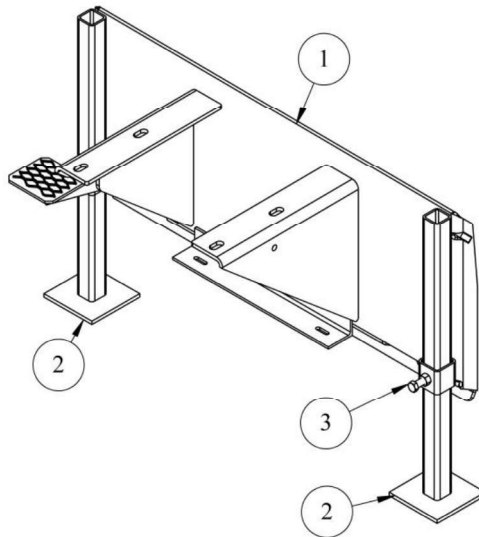

Item	Qty	Part No.	Description
1	1	MBS-77-20AA	Bracket Weldment. Driver Skid Loader
2	2	OS-4-22SFA	Leg Weldment. Storage Stand
3	2	300218	Screw, Cap 5/8-11 x 1-3/4 Hex Head Gr5 Zn (included in MBS-77-20AA)

Hydraulic Control Valves

Single & Multiple Control Lever Valves

VP-01-SP Valve – 1-Spool

VP-03-SP Valve – 3-Spool

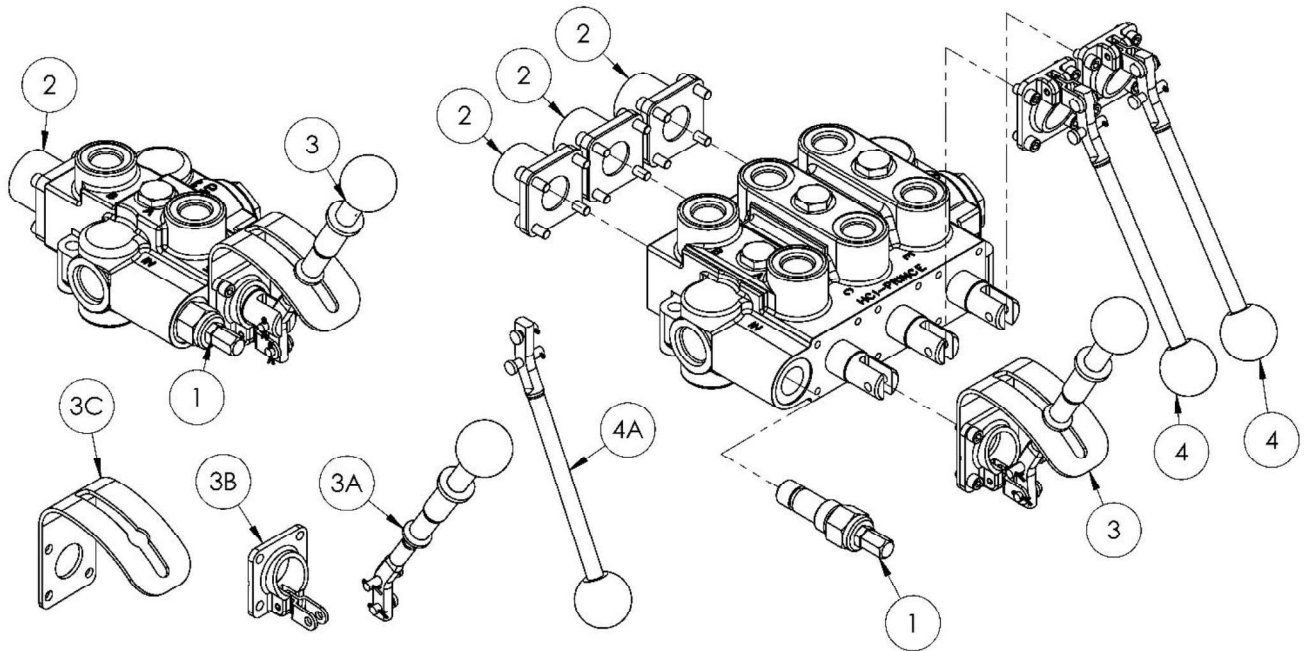

Item	Qty. VP-01-SP	Qty. VP-03-SP	Part No.	Description
1	1	1	VP-ARVC	Valve, Main Relief, Direct Acting 1800-3000 PSI (set at 2538 PSI)
2	1	3	VP-SCK	Spring Kit, Centering
3	1	1	VP-LSHK	Handle Kit, Locking Safety
3A	1	1	VP-LSHO	Handle, Only, Locking Safety
3B	1	3	VP-HC	Clevis, Handle
3C	1	1	VP-LHG	Guide, Handle Locking
4	-	2	VP-HKC	Handle Kit, Complete
4A	-	2	VP-HHK	Handle Kit, Hardware &
-	1	-	VP-01-SP-SK	Seal Kit, Single Spool (not shown)
-	-	1	VP-03-SP-SK	Seal Kit, Three Spool (not shown)
-	-	-	VP-CCK	Closed Center Kit, Prince Valve (not shown)
-	-	-	VP-PBK	Power Beyond Kit, Prince Valve (not shown)

Self-Contained Hydraulics

OH-200 - Self-Contained Mounting Package Complete

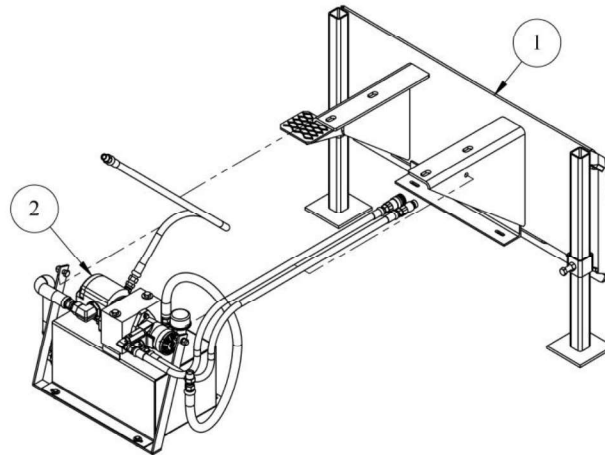

Item	Qty	Part No.	Description
1	1	MBS-77-20	Bracket Assy., Universal Mtg.
2	1	OH-101	Self-Contained Mtg. Pkg. Less Bracket.

OH-101 - Self-Contained Mounting Package Less Bracket

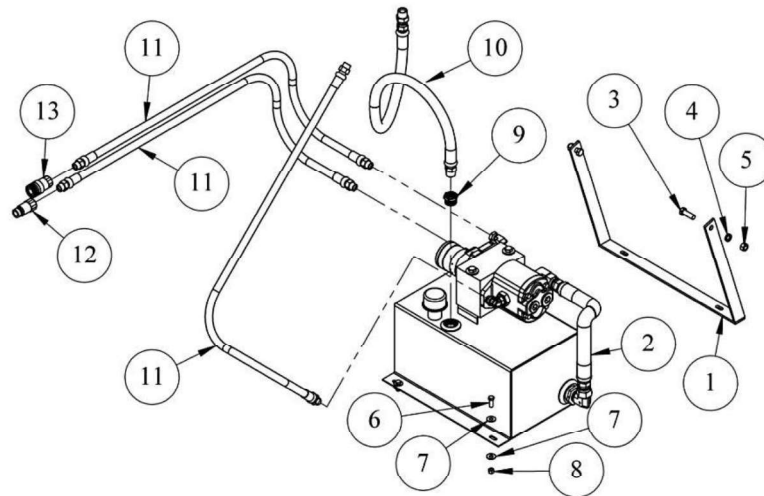

Item	Qty.	Part No.	Description
1	1	OH-101-2B	Frame Weldment, Reservoir Bracket.
2	1	OH-101-1	Self-Contained Mtg. Pkg. Less Brkt.
3	2	300326	Screw, Cap 1/2 -13 x 3 Hew Head Gr5 Zn
4	2	300101	Washer, Lock 1/2 Zn
5	2	300102	Nut, Hex 1/2-13 Zn
6	4	300189	Bolt, Tap 3/8-16 x 1" Gr5 Zn
7	8	300178	Washer, Flat 3/8 Std. Zn
8	4	300181	Nut, Lock 3/8-16 Zn
9	1	300340	Bushing, Reducer 1" NPT x 3/4"NPT
10	1	SM-10252-R	Hose Assy., Hyd. 1" x 48" 1" MNPT
11	3	SM-1022-P	Hose Assy., Hyd. 1/2" x 54" 1/2" MNPT
12	1	CT-832-MC	Coupler, 1/2" Male Flat Face
13	1	CT-832-FC	Coupler, 1/2" Female Flat Face

Self-Contained Hydraulics

OH-101-1 – Pump/Motor Kit,

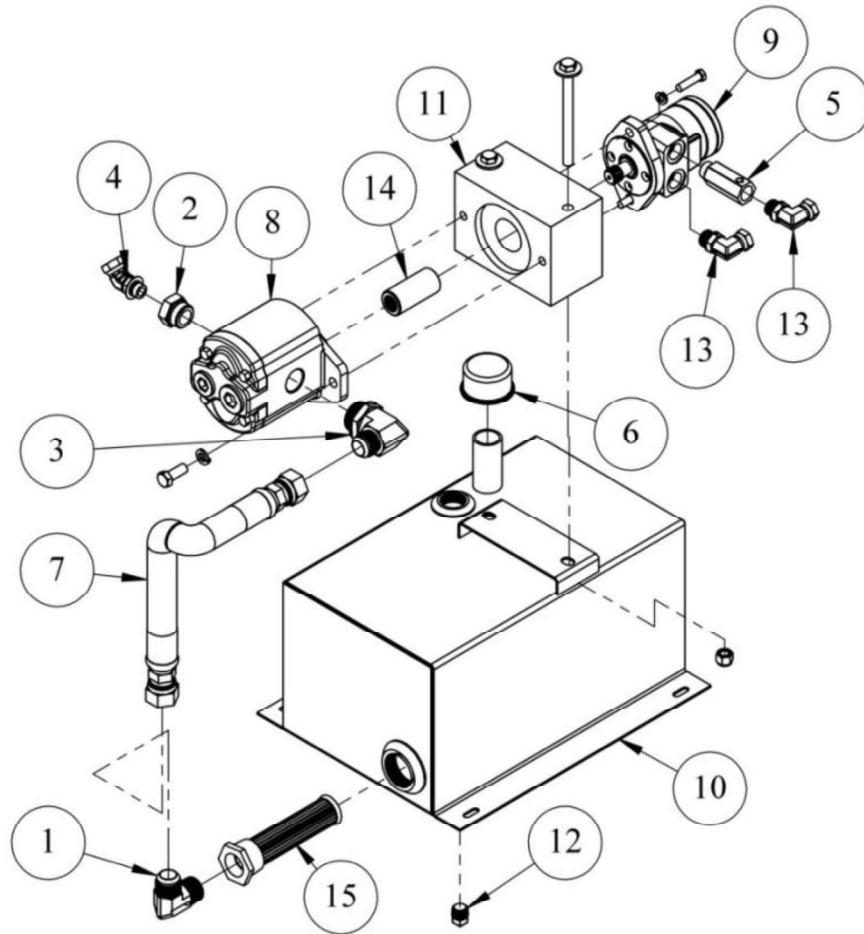

Item	Qty	Part No.	Description
1	1	700109	Adaptor, 90° SAE#16MJIC- 1" MNPT
2	1	700110	Adaptor, Straight SAE#16MORB- #8FORB
3	1	700111	Adaptor, 90° SAE#16MJIC- #20MORB
4	1	700112	Adaptor, 45° SAE#8MORB- 1/2" FNPT
5	1	CT-FC10	Valve, Check, SAE #10 Inline
6	1	OH-101-1F2	Cap, Breather
7	1	OH-101-1H	Hose Assy., Hyd. 1 x 17 SAE # 16 FJIC
8	1	OH-101-10A	Pump, Hyd. 2.69 Disp. 7/8-13T CCW
-	*	OH-101-10A-SK	Seal Kit, Pump (Not Shown)
9	1	OH-101-10B	Motor, Hyd. 3.6 Cu. In. 7/8-13T Spline
-	*	OH-101-10B-SK	Seal Kit, Motor (Not Shown)
10	1	OH-101-10F	Tank, Reservoir 8-Gal.
11	1	OH-101-10G	Mount, Adaptor Pump/Motor
12	1	OH-MP-50	Plug, Magnetic 1/2" NPT
13	2	SC-2550-C	Adaptor, 90° SAE#10MORB- 1/2" NPSM
14	1	SD-510-722	Coupling, 7/8-13T Splined 2-5/8" OD x 3"
15	1	SK-10-SMSC1A	Filter, Steel Tank 1" NPT

Driver Cylinder Assembly

SM-0263-S - Cylinder Assembly, Complete HD-8

SM-1026-S - Cylinder Assembly, Complete HD-10/12 (Shown) & SHD-10

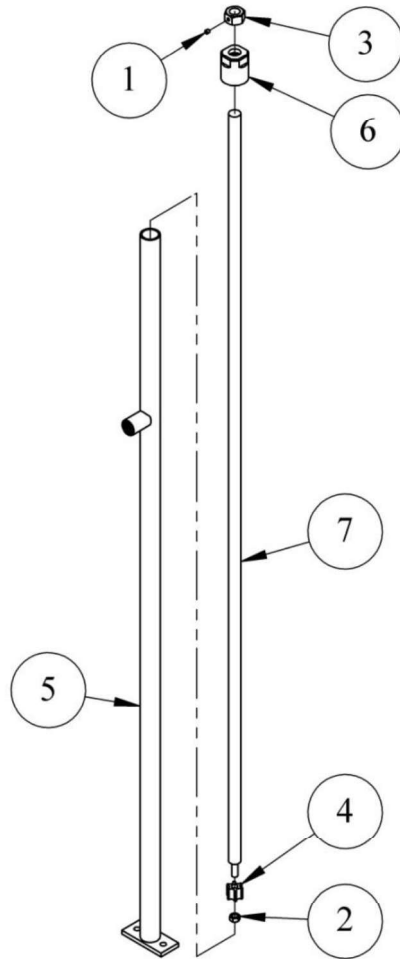

Item	Qty. SM-0263-S HD-8	Qty. SM-1026-S HD-10/12	Part No.	Description
1	1	1	300111	Screw, HSSS 5/16-18 x 5/16
2	1	1	S-0269	Nut, 1/2 F. Piston Guide, HD-8/10
3	-	1	SM-0936C	Nut, Cylinder Coarse Machine
	1	-	SM-018	Nut, 3/4-10 Side Tilt Crank
4	1	1	SM-02610	Guide, Piston, HD-8/10
5	-	1	SM-10261-S	Tube Weldment., Cylinder. HD-10/12
	1	-	SM-0264-S	Tube Weldment., Cylinder. HD-8
6	-	1	SM-10262	Cap & Seal Assy, HD-10/12
	1	-	SM-0262-D	Cap & Seal Assy, HD-8
-	-	1	SM-10265-D	Seal, Cup, HD-10/12 (included in SM-10262)
	1	-	SM-0265-D	Seal, Cup, HD-8 (included in SM-0262-D)
7	-	1	SM-10266	Rod, Piston, HD-10/12
	1	-	SM-0266	Rod, Piston, HD-8

Attachments – Pilot Augers

SM-1001-PA4 – Auger Assembly, 4” Pilot (HD-10) & SM-1001-PA6 – Auger Assembly, 6” Pilot (HD-10/SHD-10) (Shown)

SM-1201-PA4 – Auger Assembly, 4” Pilot (HD-12) & SM-1201-PA6 – Auger Assembly, 6” Pilot (HD-12)

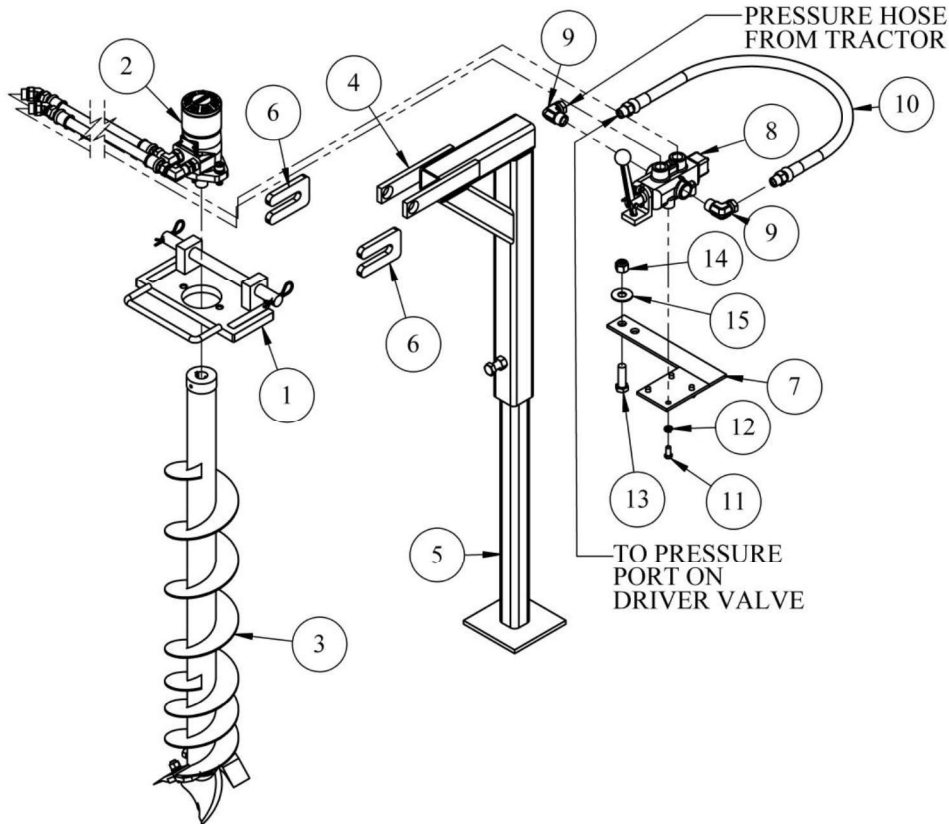

Item	HD-10 & SHD-10		HD-12		Part No.	Description
	Qty. SM-1001-PA4	Qty. SM-1001-PA6 (Shown)	Qty. SM-1201-PA4	Qty. SM-1201-PA6		
1	1	1	-	-	UTD-10PAN	Plate Assembly, Auger Mounting HD-10 /SHD-10 (Shown)
	-	-	1	1	UTD-12PAN	Plate Assembly, Auger Mounting HD-12
2	1	1	1	1	SM-1011-PA	Motor & Hose Assembly
3	1	-	1	-	SA-304-ACC	Auger Assembly, 4" w/1" Coupler
	-	1	-	1	SA-306-ACC	Auger Assembly, 6" w/1" Coupler (Shown)
4	1	1	1	1	SM-1100-PAW	Mount Weldment,
5	1	1	1	1	SK-10-SMB	Stand Weldment, Jack
6	2	2	2	2	SM-1000	Holder, Motor Mount
7	1	1	1	1	SA-001-VBP10	Bracket Weldment, Valve
8	1	1	1	1	GS-400	Valve, 4-Way, 3-Position Spool
9	2	2	2	2	HBP-910183	Fitting,
10	1	1	1	1	SM-023-P	Hose Assembly, Hyd. 1/2 x 35
11	4	4	4	4	300321	Bolt, Tap 3/8-16 x 1 Gr5 Zn
12	4	4	4	4	300182	Washer, Lock 3/8 Zn
13	1	1	1	1	300251	Bolt, HHCS 5/8-11 x 2 Gr5 Zn
14	1	1	1	1	300359	Nut, Lock 5/8-11 Nylon Zn
15	1	1	1	1	300213	Washer, Flat 5/8 Zn

Attachments – Pilot Augers

6" Auger Fish Tail & Tooth Assembly

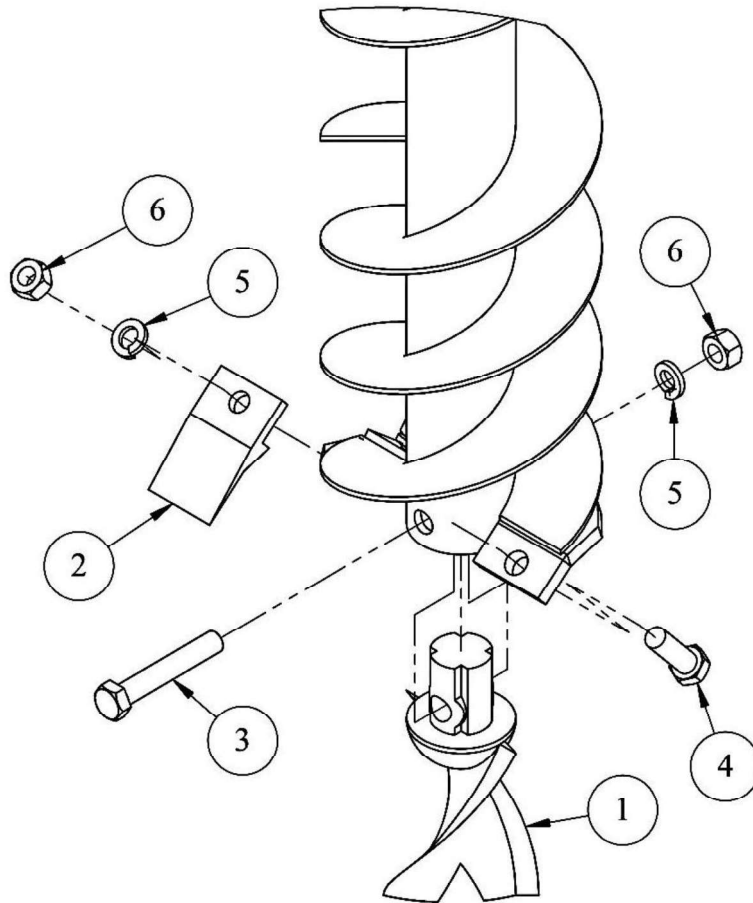

Item	Qty.	Part No.	Description
1	1	SA-304-PF	Auger Point Fish Tail
2	2	SA-6230	Auger Teeth
3	2	300236	Screw, Cap 1/2-13 x 3 Hex Head Gr2 Zn
4	1	300326	Screw, Cap 1/2-13 x 2 Hex Head Gr5 Zn
5	3	300101	Washer, Lock 1/2 Zn
6	3	300102	Nut, Hex 1/2-13 Zn

NOTE: 4" Auger has non-replaceable Fish Tail Point & Teeth.

Attachments – Pilot Augers

SM-1011-PA – Motor & Hose Assembly

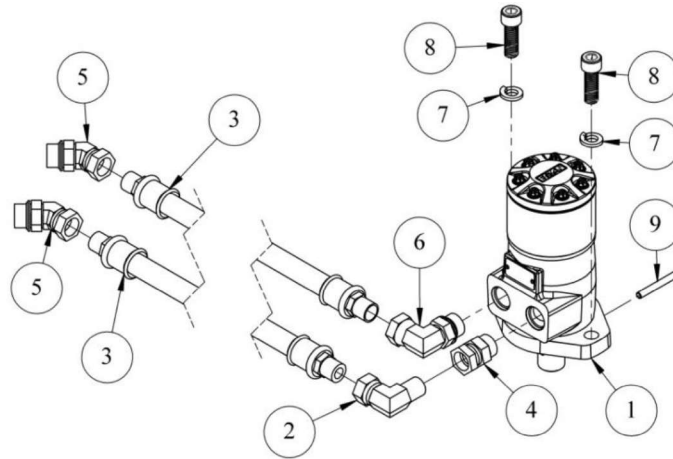

Item	Qty.	Part No.	Description
1	1	SM-1011-PAHM	Motor, Hydraulic
2	1	F-1501-08	Fitting, 90°
3	2	SM-0234-R	Hose Assy., Hyd. 1/2" x 120" 8MXMS 100R2
4	1	SD-510-83	Fitting, Swivel
5	2	700112	Adapter, 45° SAE #8 MORB-1/2" FNPT
6	1	SC-2550-C	Fitting, 90° SAE 7/8 MORB-1/2 FNPT
7	2	300101	Washer, Lock 1/2 Zn
8	2	300361	Screw, AHSS 1/2 -13 x 1-1/2 Gr5 Zn
9	1	300227	Pin, Roll 1/4 x 2-1/2

UTD-10PAN – Plate Assembly, HD-10 Motor Mount (Shown) & SHD-10

UTD-12PAN – Plate Assembly, HD-12 Motor Mount

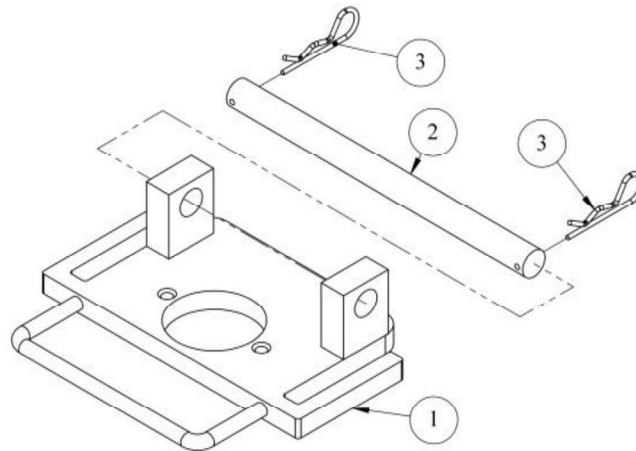

Item	Qty. UTD-10PAN (Shown)	Qty. UTD-12PAN	Part No.	Description
1	1	-	UTD-10PAN1	Plate Weldment, HD-10 Auger Mounting (Shown)
	-	1	UTD-12PAN1	Plate Weldment, HD-12 Auger Mounting
2	1	1	UTD-G31M	Pin, Power Head Holder
3	2	2	SM-1041-RLC	Clip, Road Lock

Attachments – Hydraulic

SM-SL-HRSK – Return Kit, Split, Skid Loader

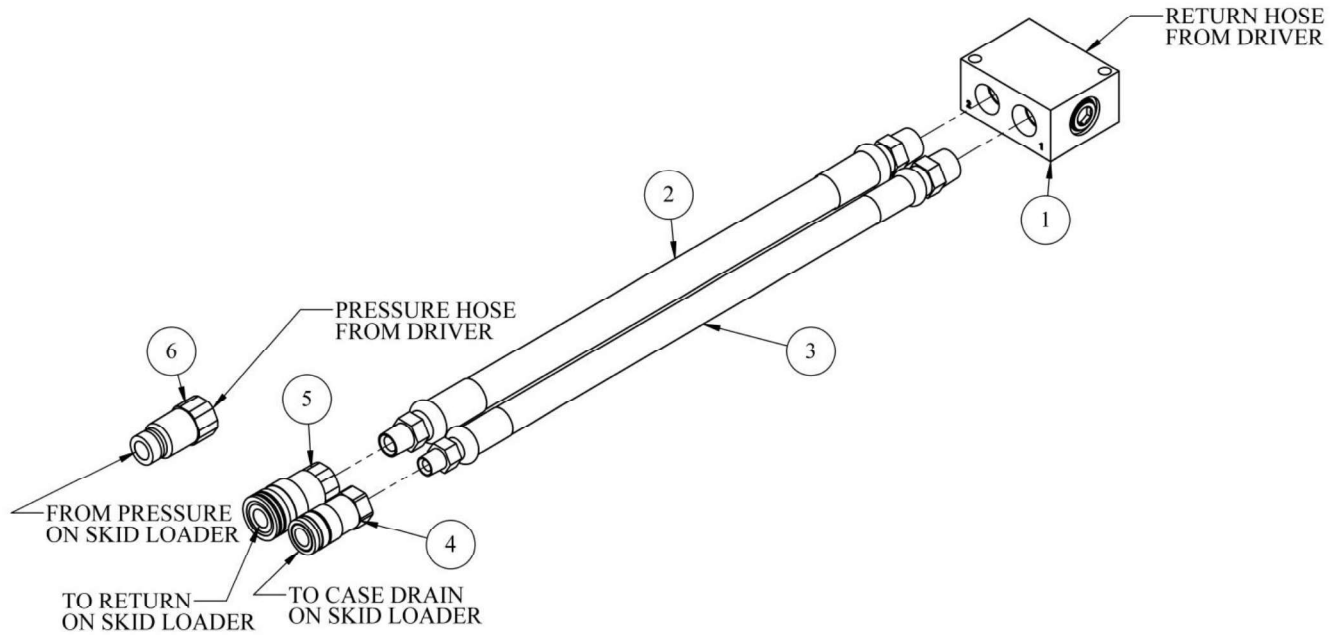

Item	Qty.	Part No.	Description
1	1	V-SLR	Valve Assembly, Skid Loader Return
2	1	SM-SLR-HR	Hose Assembly, Return, 3/4" x 23"
3	1	SM-SLR-HCD	Hose Assembly, Case Drain, 3/4" x 23"
4	1	700120	Coupler, Quick Female 3/8 NPT Flat Face
5	1	CT-832-FC	Coupler, Quick Female 1/2 NPT Flat Face
6	1	CT-832-MC	Coupler, Quick Male 1/2 NPT Flat Face

Attachments –Post Holders

SM-2-PH – Post Holder (Old Style)

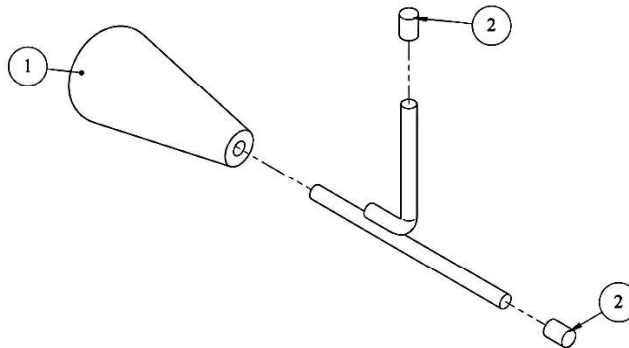

Item	Qty	Part No.	Description
1	1	PH-2	Handle
2	2	GS-001-2	Tip, Plastinol

Attachments – Steel Post Holders

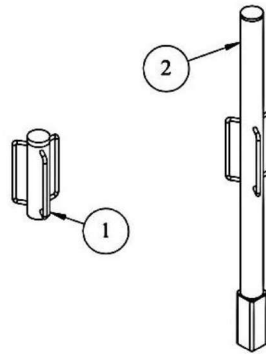

Item	Part No. HD-8 (Shown)	Part No. HD-10	Part No. HD-12	Description
1	SM-0011-PH	SM-1011-PH	SM-1211-PH	Steel Post Holder
2	SM-0011-PHSQ	SM-1011-PHSQ	SM-1211-PHSQ	Square Steel Post Holder

Attachments – Stabilizer Extensions

SM-0016 - HD-8 Stabilizer Extension

SM-1016 - HD-10/SHD-10 Stabilizer Extension (Shown)

SM-1216 - HD-12 Stabilizer Extension

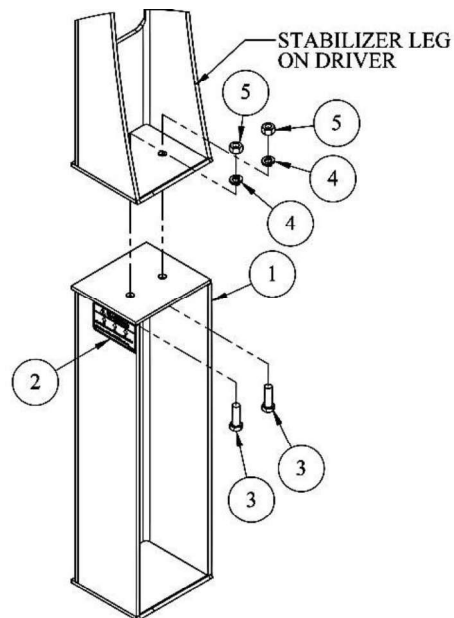

Item	Qty. HD-8	Qty. HD-10 (Shown) SHD-10	Qty. HD-12	Part No.	Description
1	1	-	-	SM-0016-SEW	Extension Weldment, Stabilizer, HD-8
	-	1	-	SM-1016-SEW	Extension Weldment, Stabilizer, HD-10
	-	-	1	SM-1216-SEW	Extension Weldment, Stabilizer, HD-12
2	1	1	1	MS-517	Decal, Warning Do Not Lower
3	2	2	2	300326	Screw, Cap 1/2-13 x 2 Hex Head Gr5 Zn
4	2	2	2	300101	Washer, Lock 1/2" Zn
5	2	2	2	300102	Nut, Hex 1/2-13 Zn

Replacement Decals

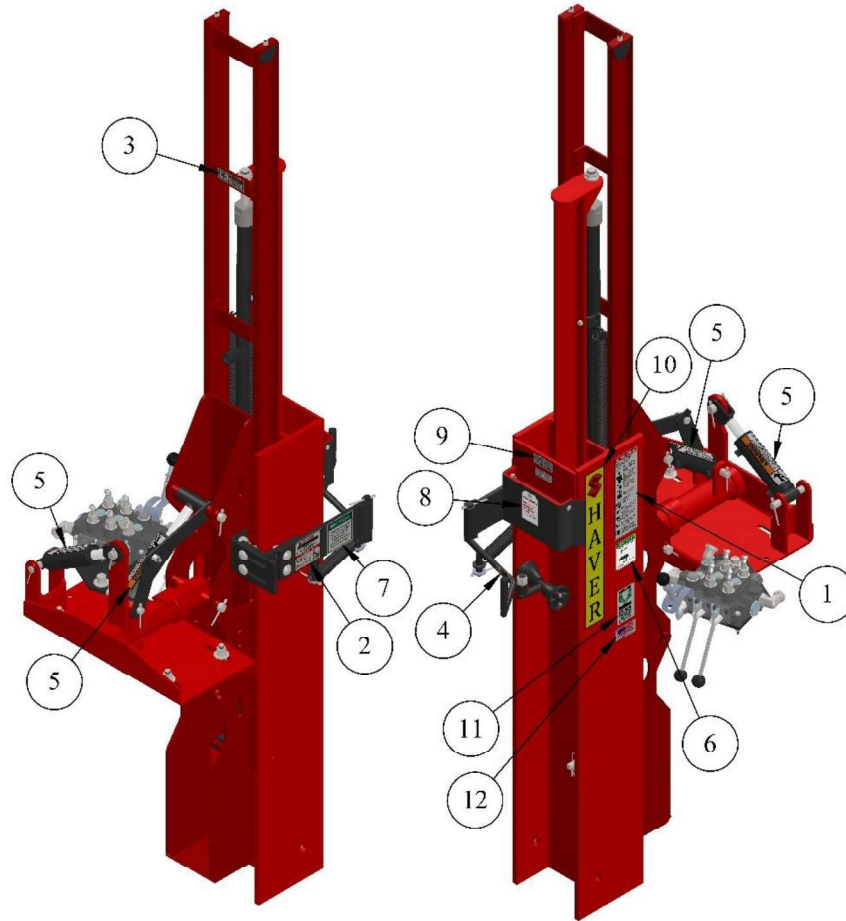

Item	Qty.	Part No.	Description
1	1	MS-183	Decal, Danger Instructions
2	1	MS-165	Decal, Danger Safety Arm Attachment
3	1	MS-163	Decal, Warning Pinch Point
4	1	MS-181	Decal, Warning Pinch Point
5	2	MS-171	Decal, Warning High Pressure Hydraulics
6	1	MS-106	Decal, Important Valve Instructions
7	1	MS-166	Decal, Important Leave Arm Open
8	1	SM-0011-ST	Tag, Caution Springs
9	1	MS-180	Decal, Cylinder Nut
10	1	MS-200D	Decal, Shaver Logo Large
11	1	MS-280	Decal, FEMA Member Large
12	1	MS-USA	Decal, Made in the USA w/Flag
-	-	MS-220	Paint, Black Spray
-	-	MS-230	Paint, Shaver Red Spray

WARRANTY POLICY

SHAYER MANUFACTURING COMPANY

Shaver products are covered under warranty for 1 year from the date of purchase.

Claims must be submitted to the factory by the distributor for authorization before replacement parts are shipped.

Parts NOT covered under warranty: Driving Ram Springs, Plastic/Nyrim Guides, PTO Shaft Covers, Rubber Debris Guards, Rubber Bumpers, Stump Grinder Teeth, Auger Teeth and Points.

Any misuse by the end user will VOID Warranty.

All replacement parts will only have a 90-day Warranty.

Shaver warrants repairs on its products using genuine Shaver parts. Any variation of this practice will be reimbursed at no more than the value of the Shaver part(s) that should have been used to repair it.

Modifying any Shaver product or the use of Teflon tape on a Shaver product voids the product warranty.

The warranty procedure for filling a claim is to submit a claim to the dealer. The dealer shall turn the claim into their distributor. Shaver will credit valid warranties to the distributor. The distributor will work with the dealer to assure that the consumer has been credited properly for the parts or repairs as needed.

It is at the discretion of Shaver Mfg. to request a part back for warranty inspection. The distributor may or may not be asked to return a part based on the decision made upon receipt of the filed warranty claim. If the part needs to be returned, Shaver will arrange return by a call tag or by freight. If warranty credit is due, back freight will also be paid in reimbursement.

A warranty cycle can take up to 6 weeks to complete. Shaver asks that each leg of the cycle act in a prompt manner to ensure the fastest warranty consideration to the end user. If a warranty claim remains open for two months, then the warranty claim will be closed, and no credit will be issued.

For any questions, or RGA No. for a return, call (712) 859-3293

Warranty Registration

Delivery Date _____ Ultimate User _____

Address _____

City, State (Province) _____ Zip/Postal Code _____

Country _____ Telephone (____) _____

Dealer/Distributor Name _____

Dealer/Distributor Customer Number _____ Telephone (____) _____

Address _____

City, State (Province) _____ Zip/Postal Code _____

Country _____

To be completed by DEALER / DISTRIBUTOR or ULTIMATE USER:

_____ Product serial number

_____ Product model number

Please make a copy of this WARRANTY REGISTRATION form for your records and return the original.

This form must be completed and returned to Shaver within 30 days from receipt of delivery or warranty may become void.

Shaver Manufacturing Company

P.O. Box 385, Graettinger, IA 51342

Phone: 712-589-3293

Fax: 712-589-3294

Website: www.shavermfg.com

E-mail: sales@shavermfg.com



www.FarmEquip.org