

11. Spare parts a

▪ CARRIAGE FRAME ASSEMBLY

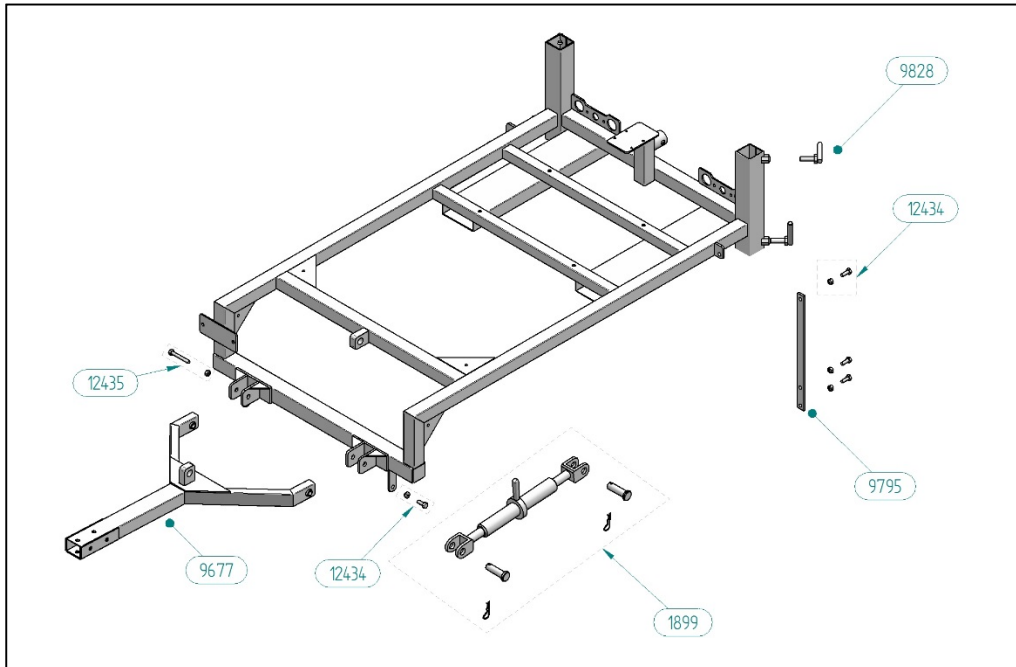

PART NO.	DESCRIPTION
1899	RACHET SET
9677	TOW BAR
9795	REAR HEIGHT ADJUSTMENT ARM
9828	CLAMP BOLT, M16
12434	BOLT+NYLOC NUT M10
12435	BOLT+NYLOC NUT M16

■ CENTRAL CHASSIS ASSEMBLY

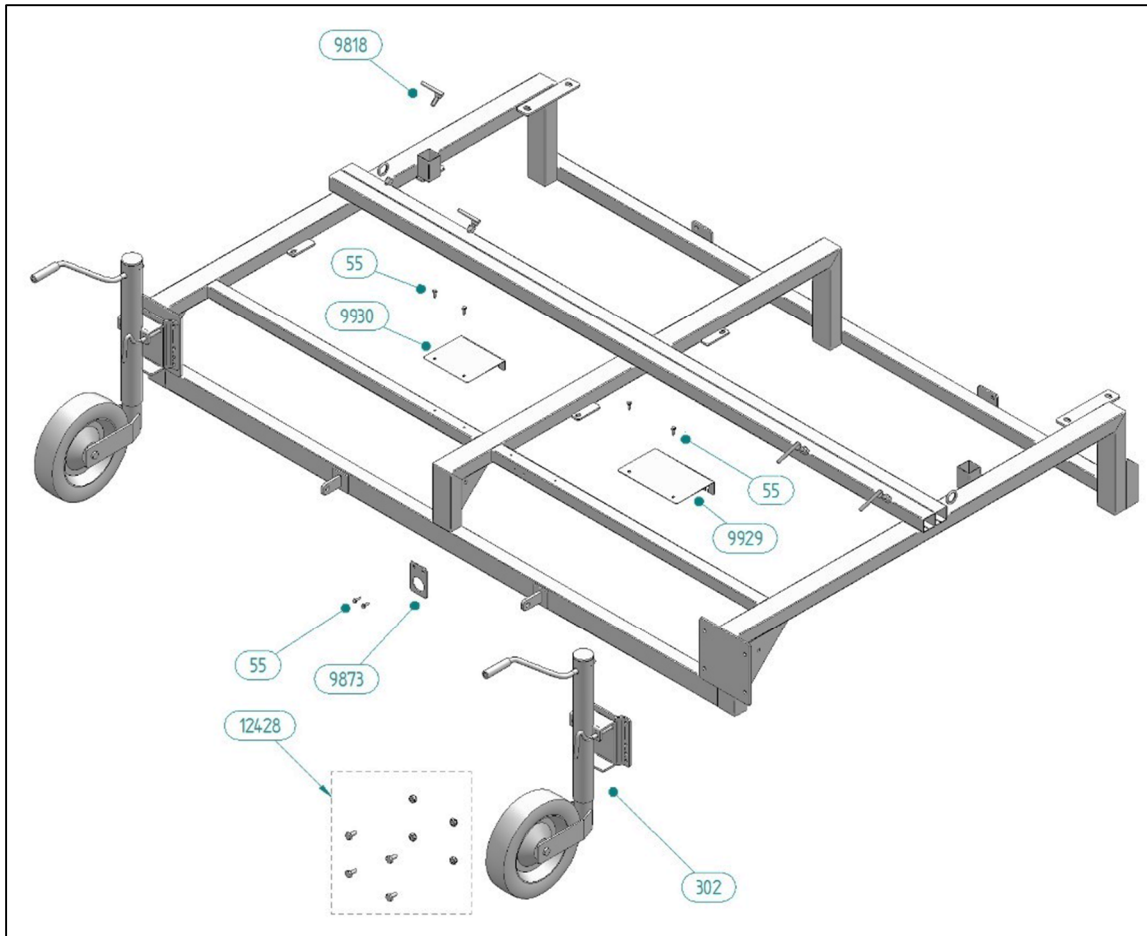

PART NO.	DESCRIPTION
55	SCREW, M6X10 DIN 933
302	JOCKEY WHEEL, 90° SWIVEL
9818	CLAMP BOLT, M10
9873	CONDUIT MOUNTING PLATE
9929	4 CONDUITS MOUNTING BRACKET
9930	3 CONDUITS MOUNTING BRACKET
12428	SREWS SET, FOR JOCKEY WHEEL

▪ CARRIAGE FRAME ASSEMBLY

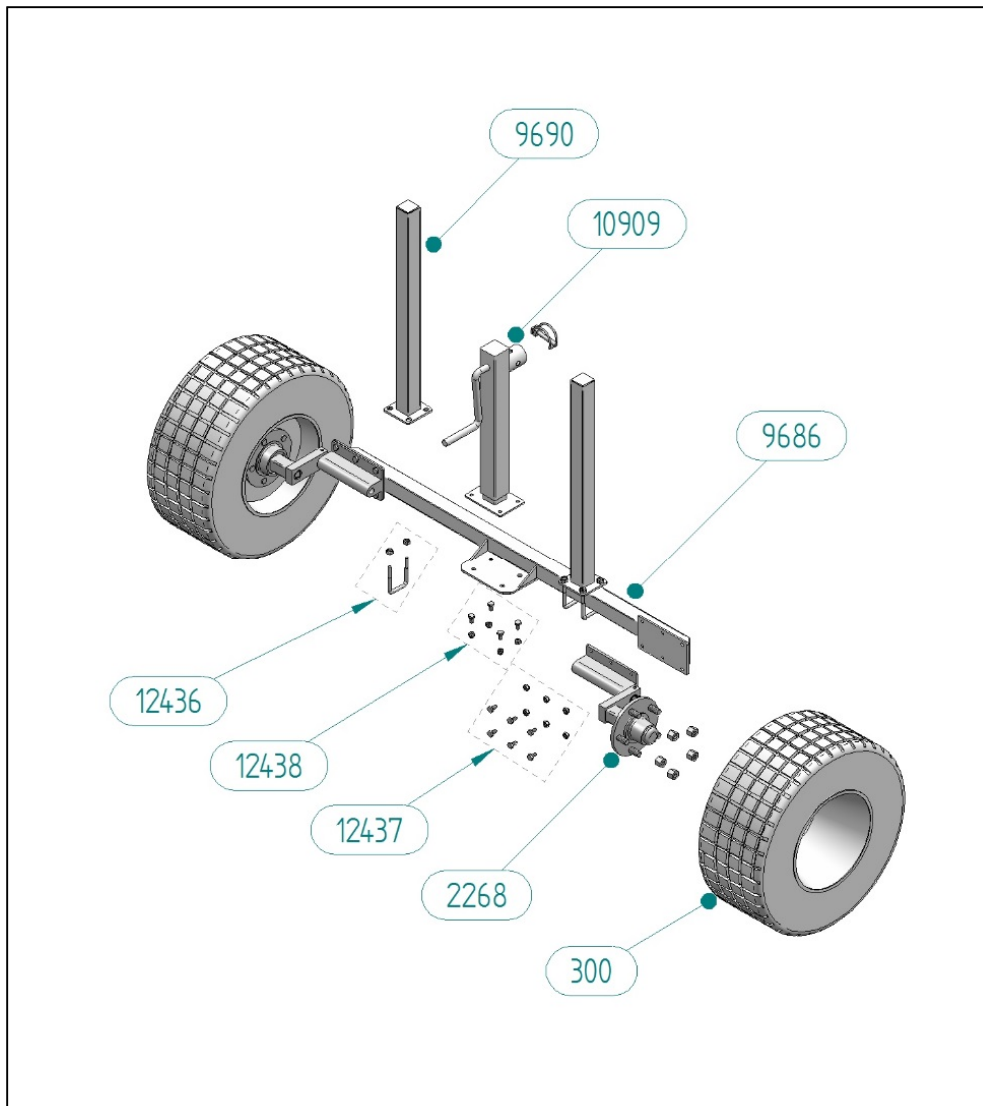

PART NO.	DESCRIPTION
300	WHEEL AND TYRE ASSEMBLY, 23x10.5-12
2268	SUSPENSION ASSEMBLY, WITH FIXING AND WHEEL NUTS
9686	WHEEL MOUNT
9690	VERTICAL SUPPORT
10909	JACK, REAR HEIGHT ADJUSTMENT
12436	U-BOLT, M10
12437	SCREWS SET
12438	SCREWS SET

- SLIDE TUBES ASSEMBLY

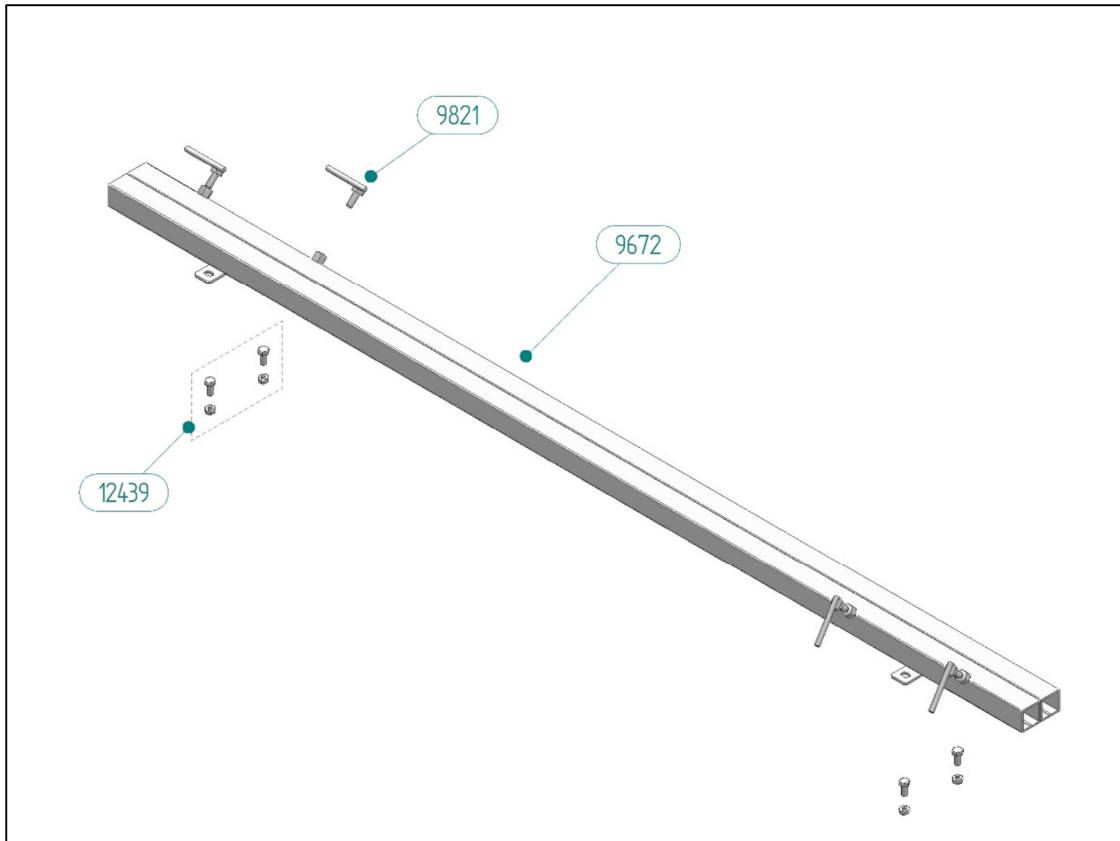

PART NO.	DESCRIPTION
9672	SLIDE TUBES, OUTER
9821	CLAMP BOLT, M12
12439	SCREWS SET

- Shield assembly

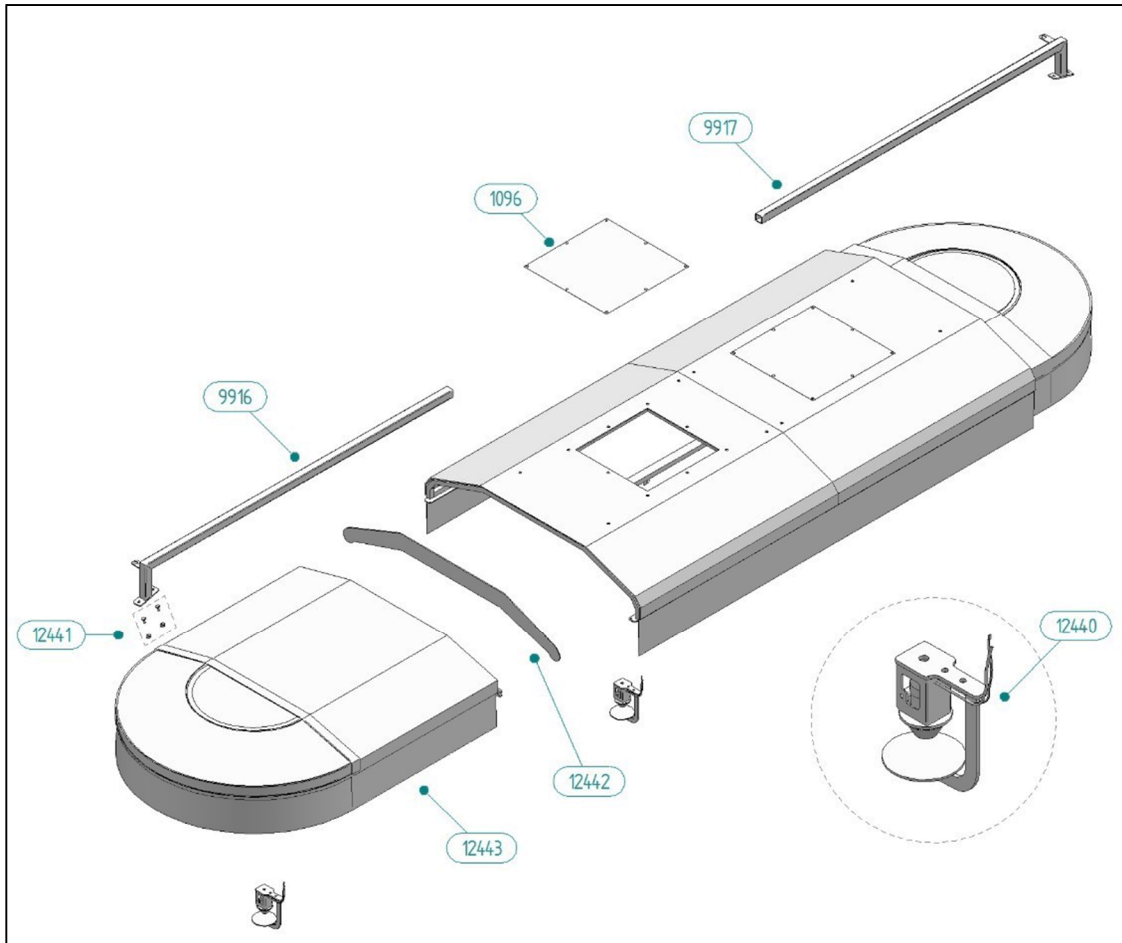

CÓDIGO	DESCRIPCIÓN
1096	COVER
9916	SLIDE INNER, RH
9917	SLIDE INNER, LH
12440	HEAD ASSEMBLY, CDA
12441	SCREWS SET
12442	RUBBER SEAL + ALUMINIUM EXTRUSION
12443	WING, COMPLETE (BOTH RH, LH)

■ 1200 CDA DOME ASSEMBLY

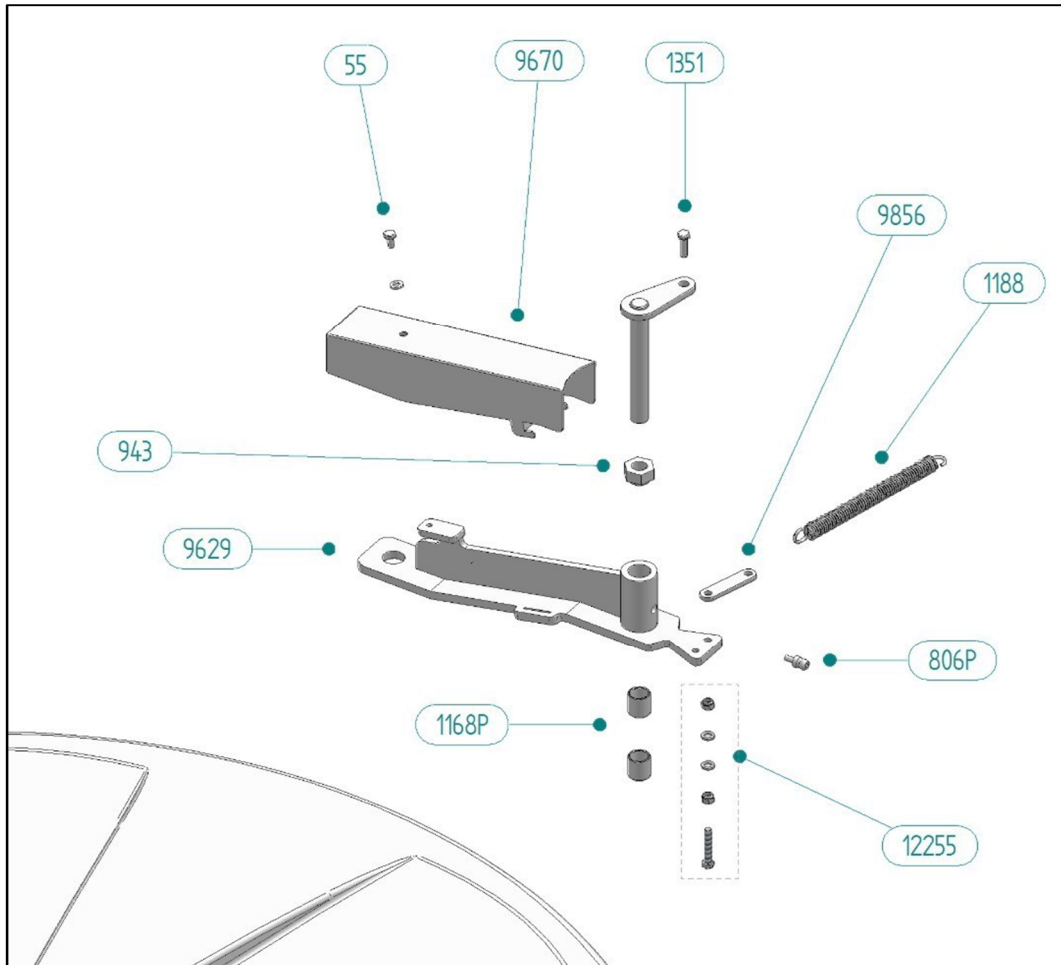

PART NO.	DESCRIPTION
55	SCREW, M6x10 DIN 933
806P	GREASE NIPPLE, M10.15
943	NYLOC NUT, M16 DIN 985
1168P	SELF LUBRICATING BEARING (X2)
1188	TENSION SPRING
1351	SCREW, M8x15 DIN 933
9629	PIVOT ARM
9670	PIVOT ARM GUARD
9755	Ø16 THREADED SHAFT
9856	CONNECTING LINK
12255	SCREWS SET

■ 1200 CDA DOME ASSEMBLY

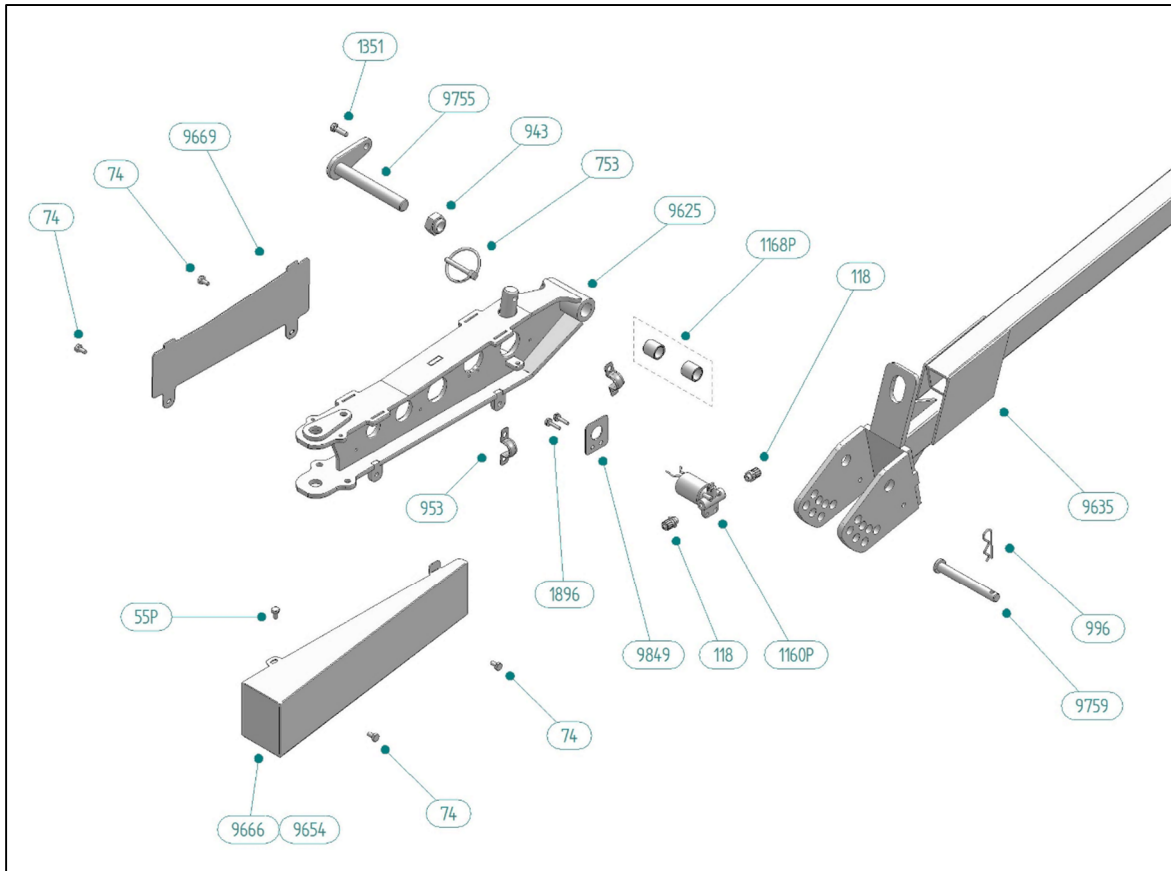

PART NO.	DESCRIPTION
55	SCREW, M6x10 DIN 933
74	SCREW, M6x15 DIN 933
118	ADAPTER, 1/8 x 6 mm
753	LINCHPIN (6 mm)
806P	GREASE NIPPLE, M10.15
943	NYLOC NUT, M16 DIN 985
953	SADDLE CLAMP Ø16 mm
996	R-PIN Ø 3 mm
1160P	SOLENOID 12 V
1168P	SELF LUBRICATING BEARING (X2)
1351	SCREW SET, M8X15 DIN 933
1896	SCREW, M5X10 DIN-7380 INOX
9625	CHASSIS ARM
9635	OFFSET INNER SLIDE
9654	CHASSIS ARM FRONT GUARD, LH
9666	CHASSIS ARM FRONT GUARD, RH
9669	CHASSIS ARM REAR GUARD
9755	Ø16 THREADED SHAFT
9759	Ø 12 PIN
9849	SOLENOID MOUNT BRACKET

- 1200 CDA DOME ASSEMBLY

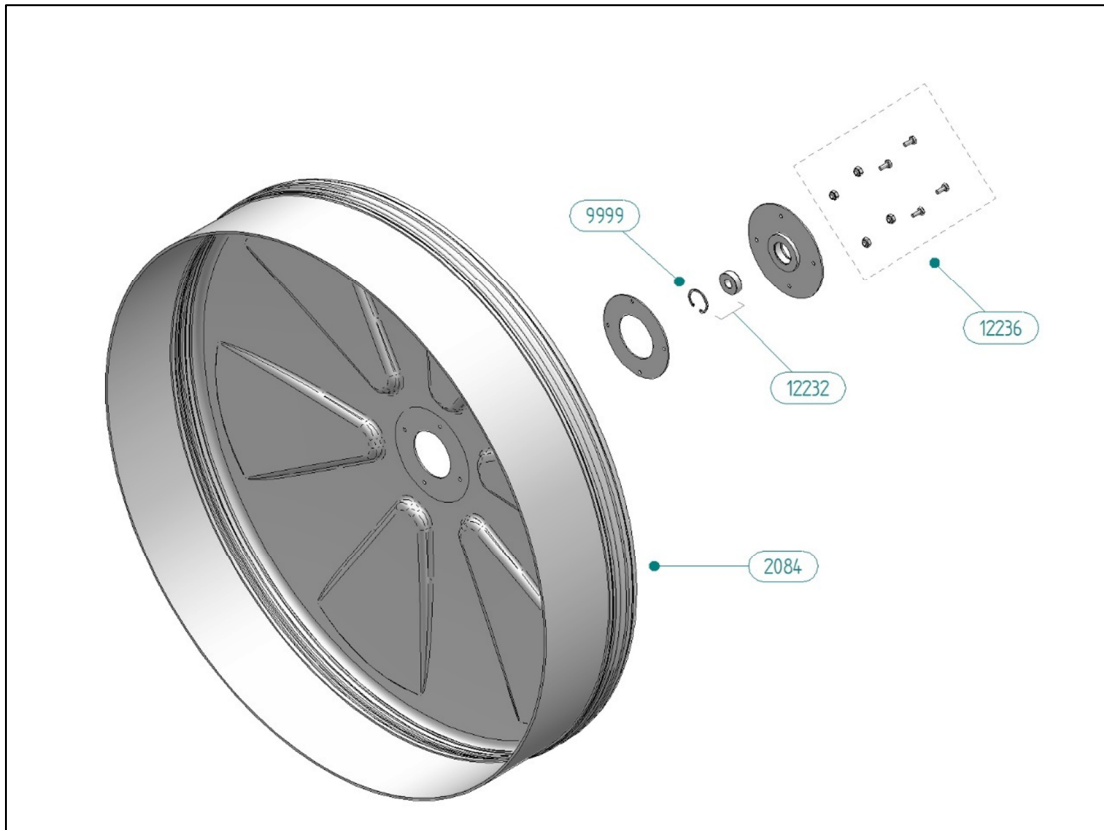

PART NO.	DESCRIPTION
2084	1200 DOME
9999	CIRCLIP, 50,5 mm
12232	BEARING SET
12236	SCREWS SET

■ CONTROL BOX

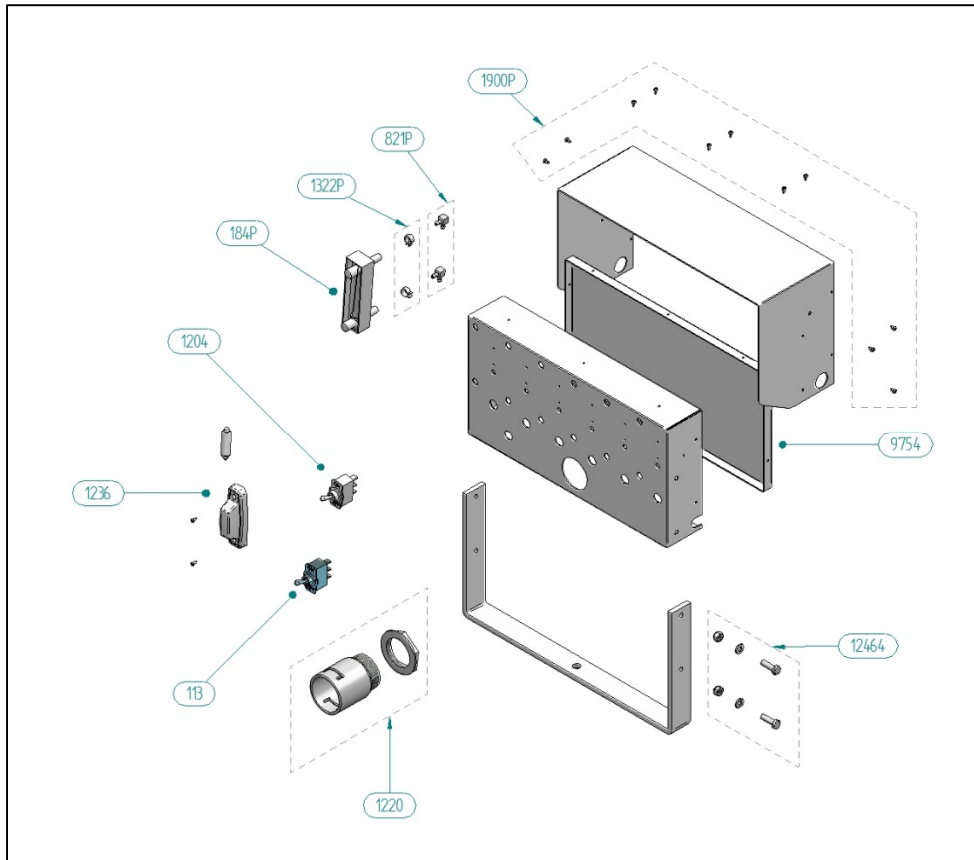

PART NO.	DESCRIPTION
113	SWITCH, DOUBLE, ON-OFF-ON
184P	FLOW METER, 30 L/h
821P	ELBOW SET (x2)
1204	SWITCH, SINGLE, ON-OFF
1220	M40 STRAIGHT FITTING
1236	LAMP ASSEMBLY
1322P	CLAMP SET (x2)
1900P	SCREWS SET
9754	CONTROL BOX
12464	SCREWS SET

■ TANK SYSTEM ASSEMBLY

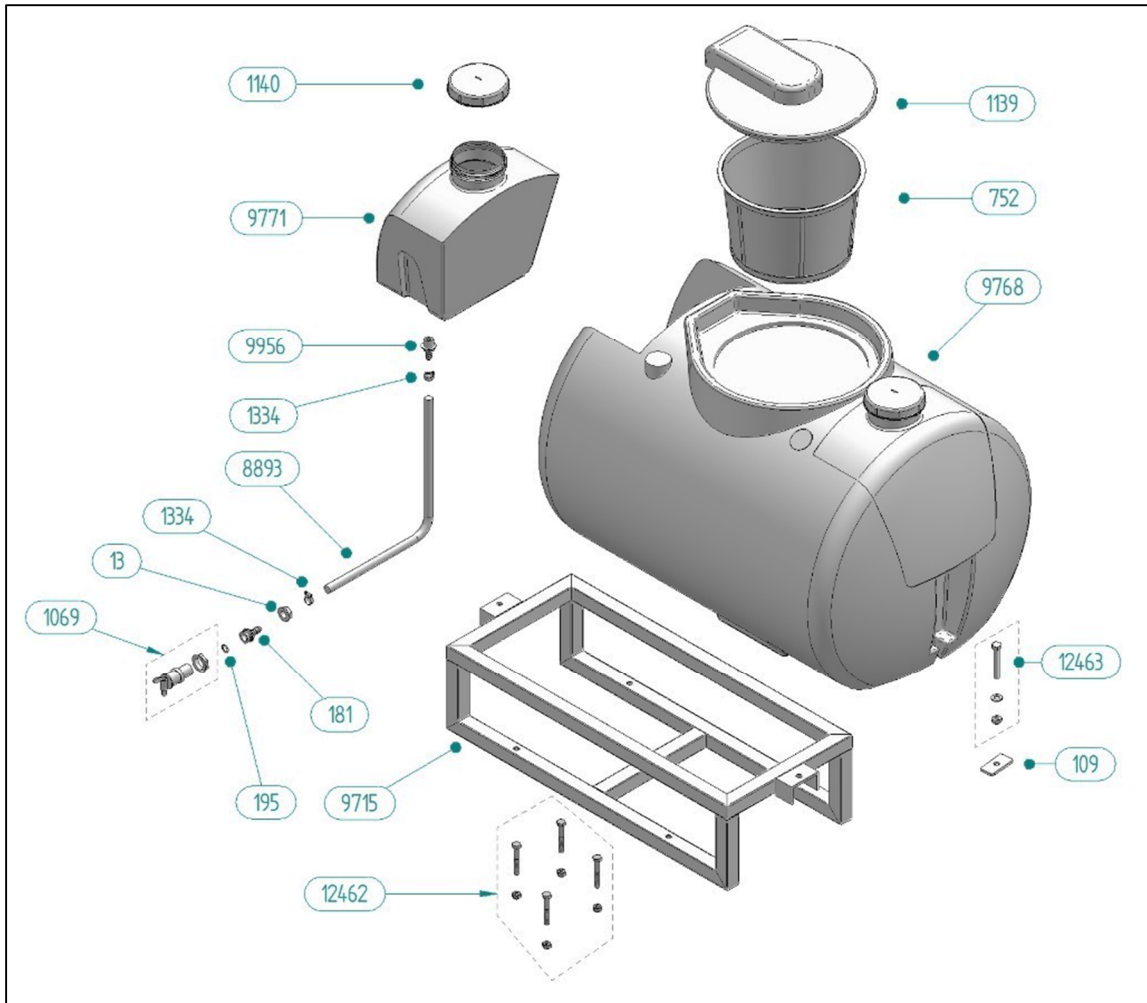

PART NO.	DESCRIPTION
13	HOSE BARB (FOR 3/4" NUT)
109	TANK FIXING PLATE
181	JOINT, 1/2"
195	NUT 3/4"
752	TANK FILTER, 200 L
1069	VALVE
1139	TANK LID, 200 L
1140	TANK LID, 20 L
1334	CLAMP, 13-19 mm
8893	HOSE, 12x18 mm
9715	TANK CHASSIS, 200 L
9768	TANK, 200 L
9771	TANK, 20 L (RINSE AND HAND WASH)
9956	HOSE BARB, 1/2" M
12462	SCREWS SET
12463	SCREWS SET

■ TANK SYSTEM ASSEMBLY

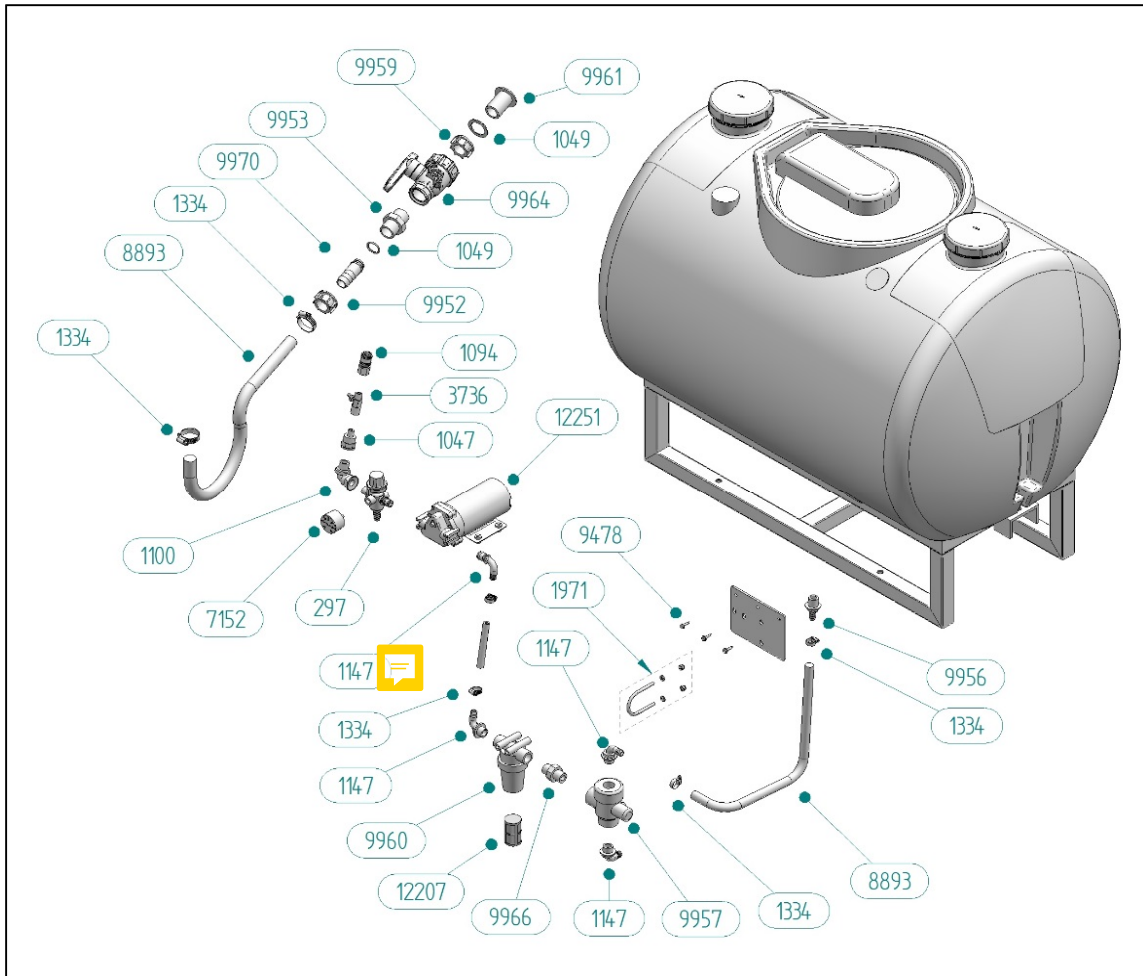

PART NO.	DESCRIPTION
235	ELBOW, QUICK RELEASE
297	PRESSURE REGULATOR
1047	ADAPTER, ¼" x 1/2", M/F
1049	JOINT
1094	SOCKET, QUICK RELEASE, ¼" F
1100	ELBOW, ½" M/F
1147	ELBOW, ½" M
1334	CLAMP 13-19 mm
1971	U-BOLT SET, 1 ¼"
3736	VALVE, ¼" M/H
7152	MANOMETER, 6 BAR
8893	HOSE 12x18 mm
9478	SELF-TAPPING SCREW
9952	NUT, 1"
9953	ADAPTER, 1"
9956	HOSE BARB, ½" M
9959	NUT, 1"
9960	FILTER
9961	FLANGE, BULKHEAD, 1"
9964	BALL VALVE, 1"
9966	ADAPTER, ½" MM
9970	HOSE BARB (FOR 1" NUT)
11642	BALL VALVE, 3 WAYS, 1"
12251	PUMP SET

▪ TANK SYSTEM ASSEMBLY

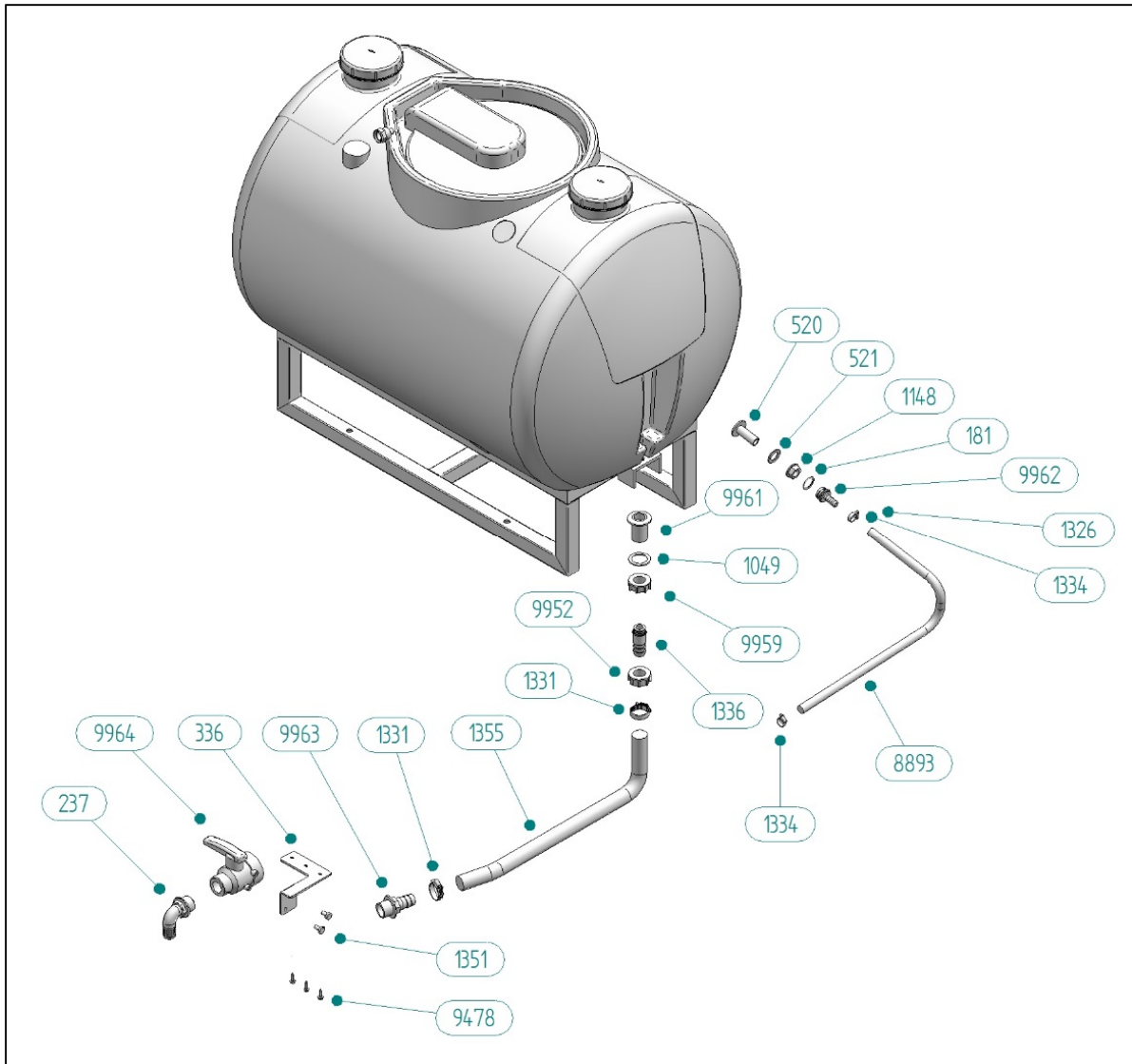

PART NO.	DESCRIPTION
181	O' RING
520	FLANGE, BULKHEAD, ½"
521	JOINT, ½"
1049	JOINT, 1"
1148	NUT, ½"
1326	NUT, ½"
1334	CLAMP, 13-19 mm
1351	SCREW, M8X15 DIN 933
9478	SELF-TAPPING SCREW
9959	NUT, 1"
9961	FLANGE, BULKHEAD, 1"
9962	HOSE BARB (FOR 1/2" NUT)

- SHIELD CDA HEAD ASSEMBLY

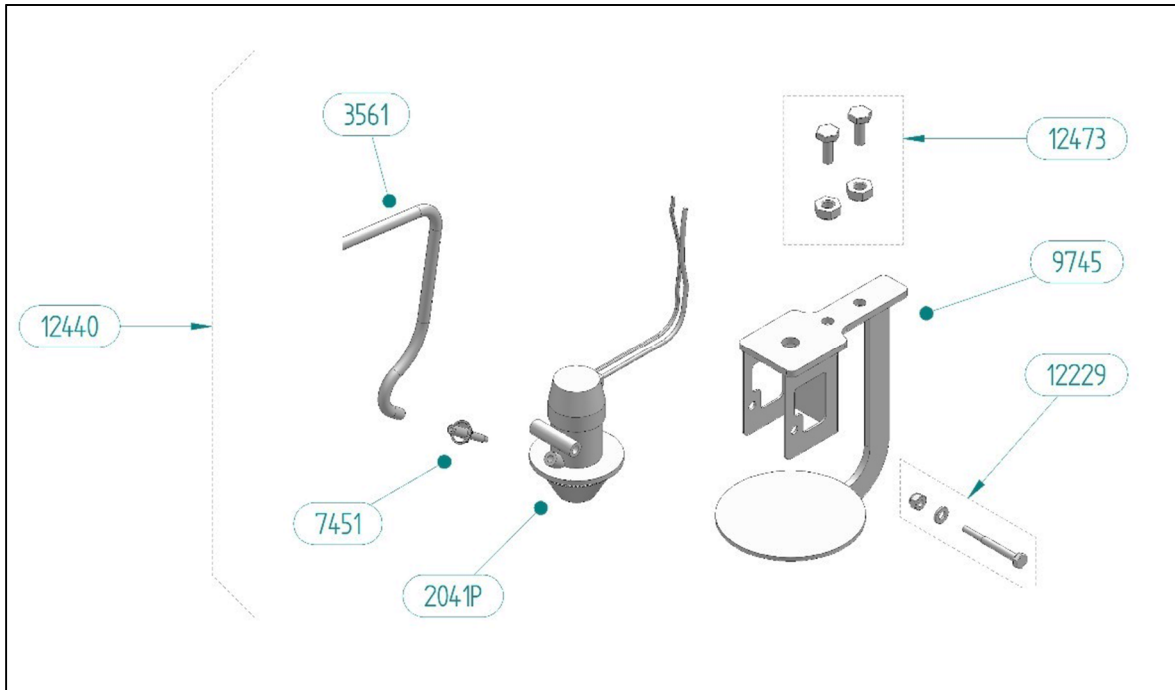

PART NO.	DESCRIPTION
2041P	CDA HEAD WITH ATOMISER DISC
3561	FEED TUBE 6 mm
7451	FEED NOZZLE
9745	SHIELD CDA HEAD BRACKET
12229	SCREWS SET
12440	SHIELD CDA HEAD SET
12473	SCREWS SET

- 1200 DOME CDA HEAD ASSEMBLY

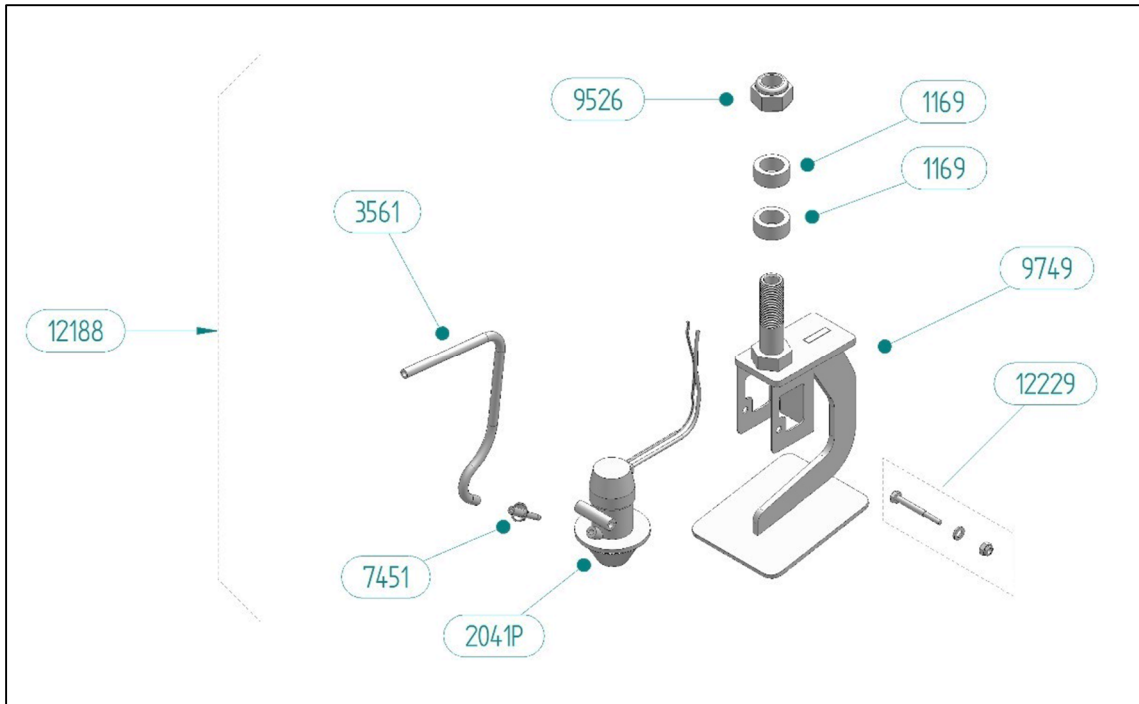

PART NO.	DESCRIPTION
1169	SPACER
2041P	CDA HEAD WITH ATOMISER DISC
3561	FEED TUBE
7451	FEED NOZZLE
9526	NYLOC NUT, M20 DIN 985
9749	DOME CDA HEAD BRACKET
12188	DOME CDA HEAD SET (WITHOUT SPACERS, CODE 1169)
12229	SCREWS SET

- CDA HEAD SET

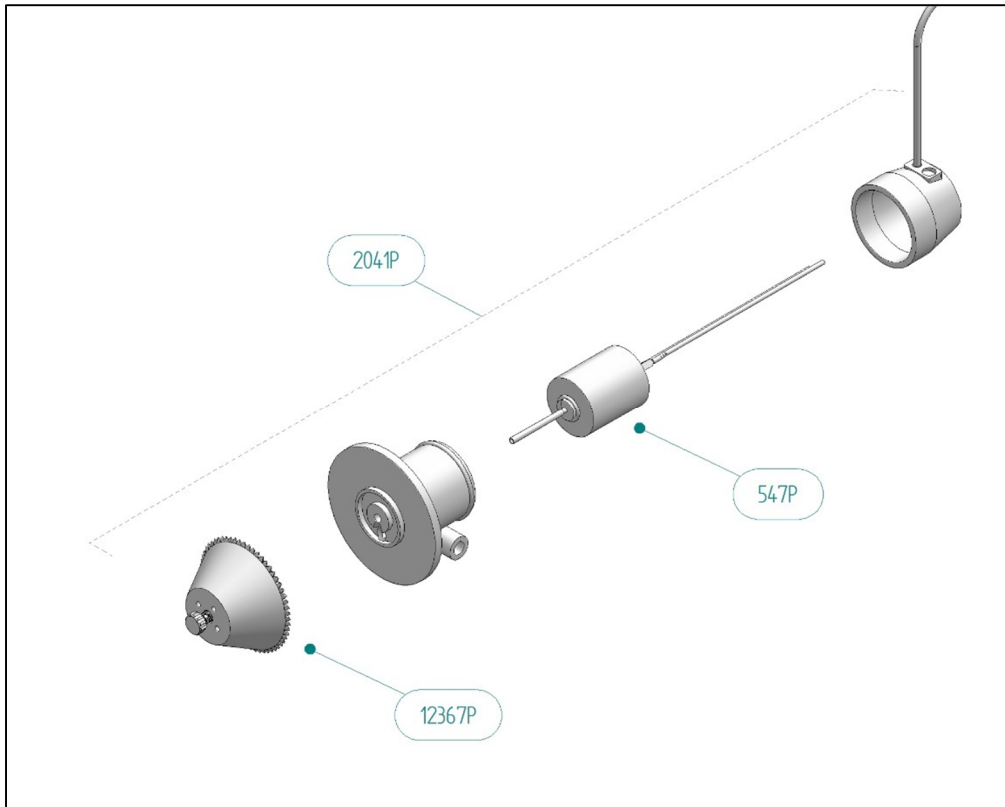

PART NO.	DESCRIPTION
547P	MOTOR
2041P	CDA HEAD WITH ATOMISER DISC
12367P	ATOMISER DISC SET

▪ PUMP ASSEMBLY

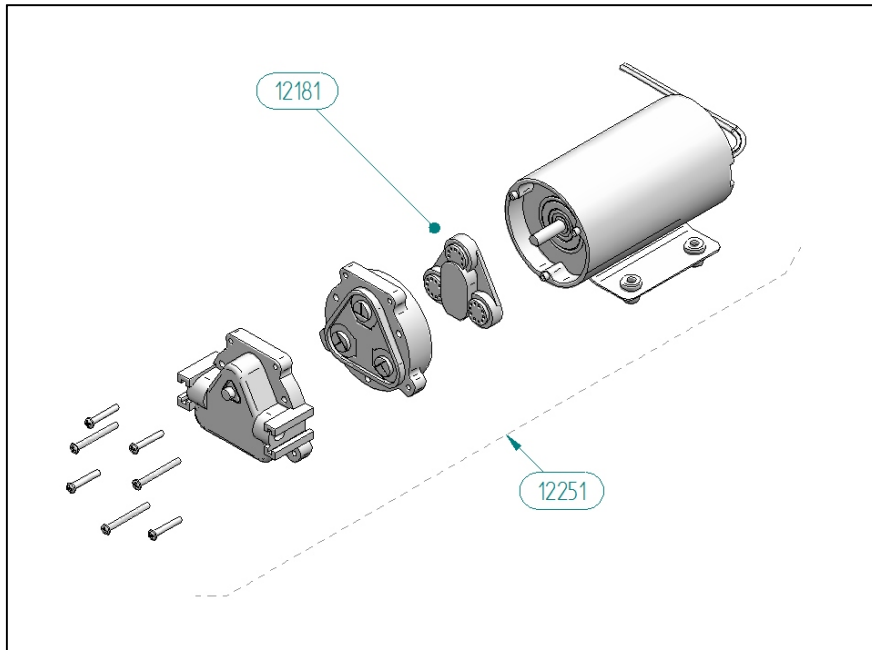

PART NO.	DESCRIPTION
12181	PUMP MEMBRANE
12251	PUMP SET

- HOSE & CABLE ASSEMBLY
- 4 HEAD CENTRAL SHIELD. CENTRAL HEADS

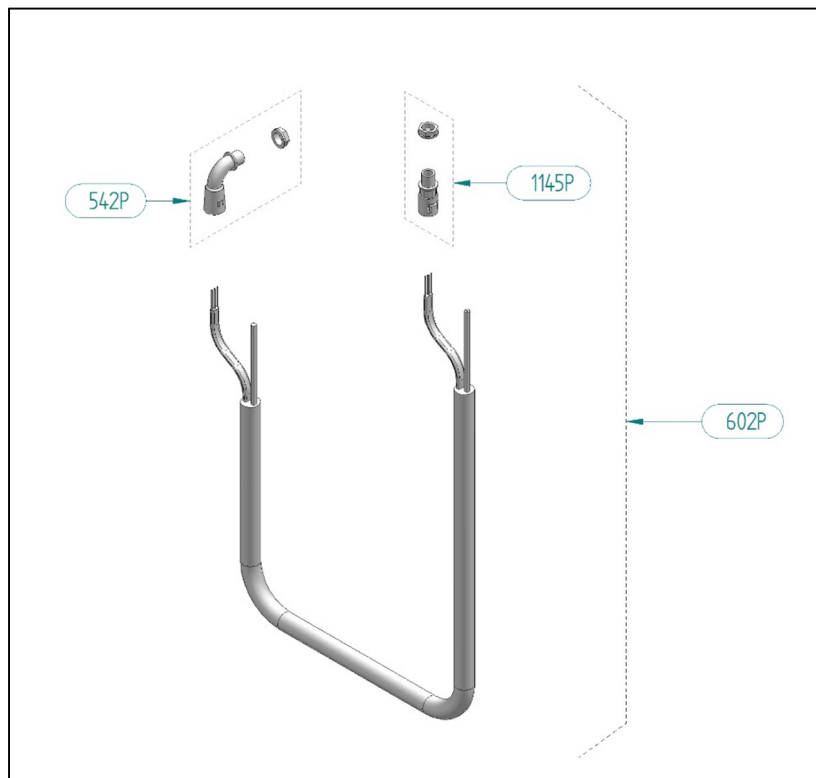
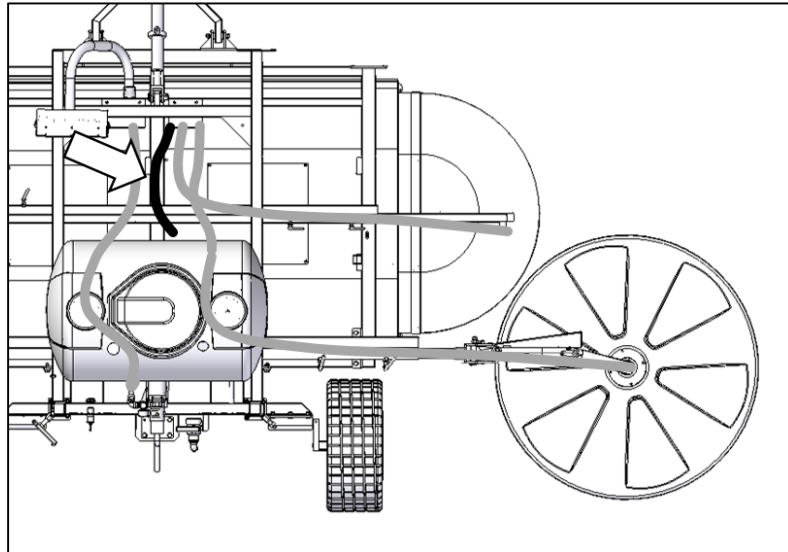

PART NO.	DESCRIPTION
542P	M16 CURVED FITTING
602P	CENTRAL HOSE & CABLE ASSEMBLY
1145P	M16 STRAIGHT FITTING

- 4 HEAD CENTRAL SHIELD. RH WING & LH WING

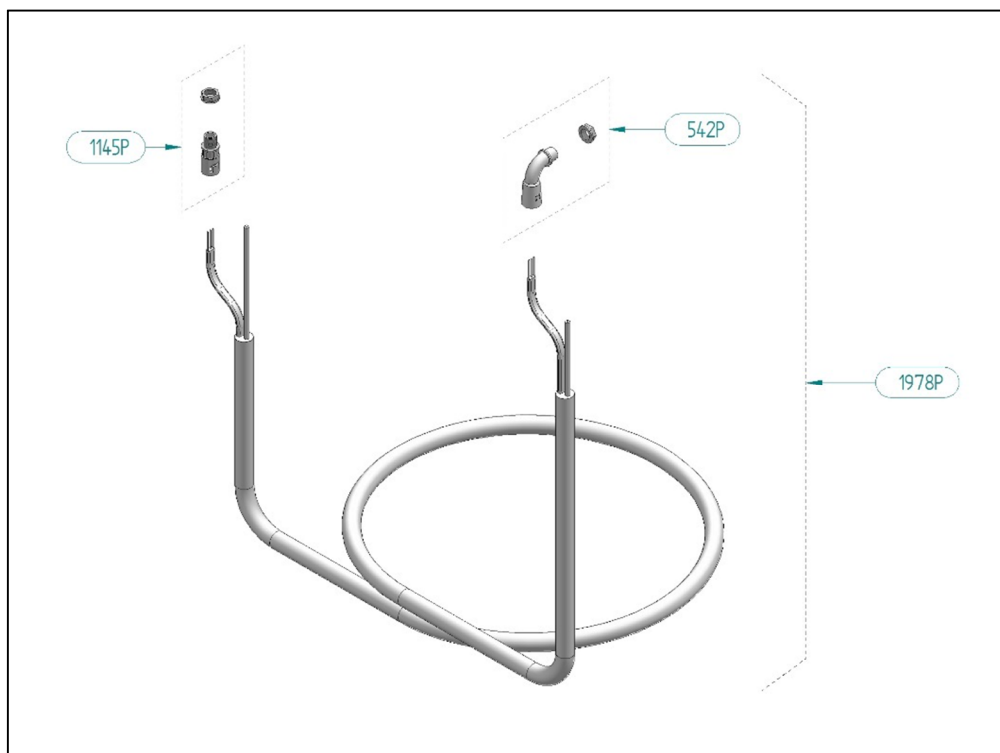
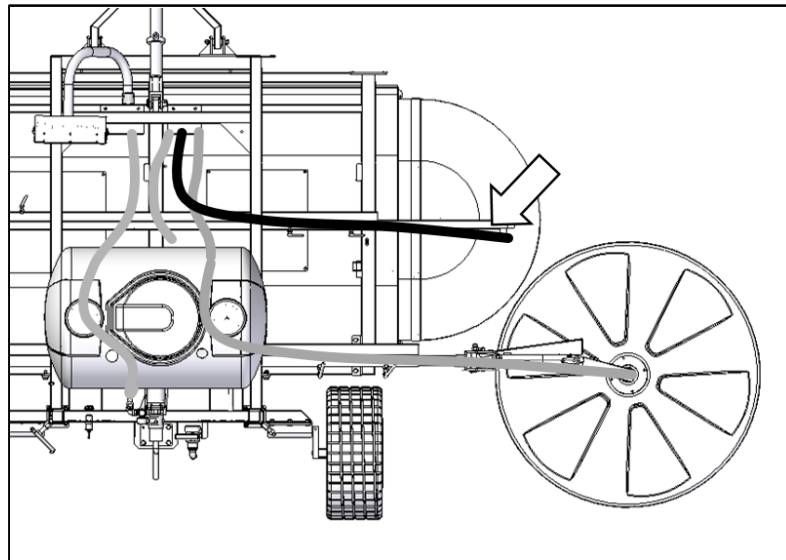

PART NO.	DESCRIPTION
542P	M16 CURVED FITTING
1145P	M16 STRAIGHT FITTING
1978P	WING HOSE & CABLE ASSEMBLY

- 1200 CDA DOME. PART 1

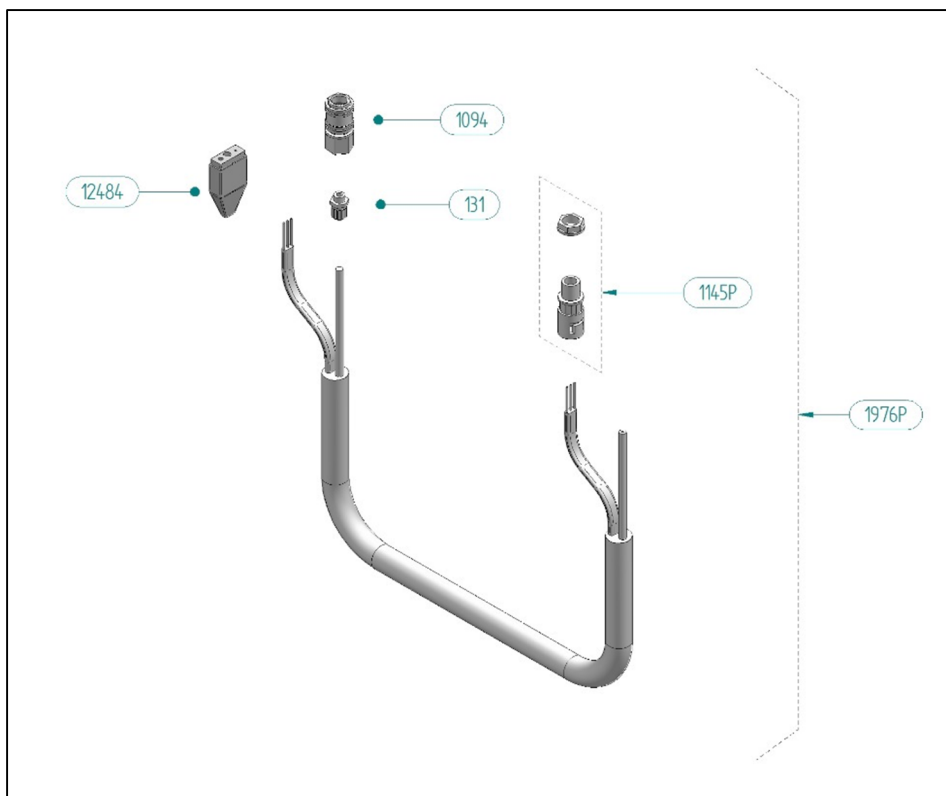
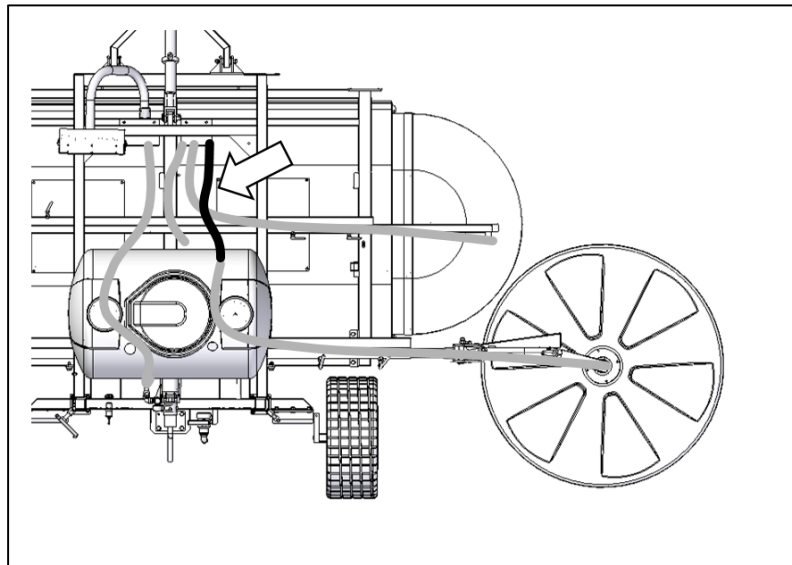

PART NO.	DESCRIPTION
131	ADAPTER, 1/8"
1094	SOCKET. QUICK RELEASE, 1/4" F
1145P	M16 STRAIGHT FITTING
1976P	1200 DOME HOSE & CABLE ASSEMBLY, PART 1
12484	SOCKET, 3 PIN, INLINE

- 1200 CDA DOME. PART 2

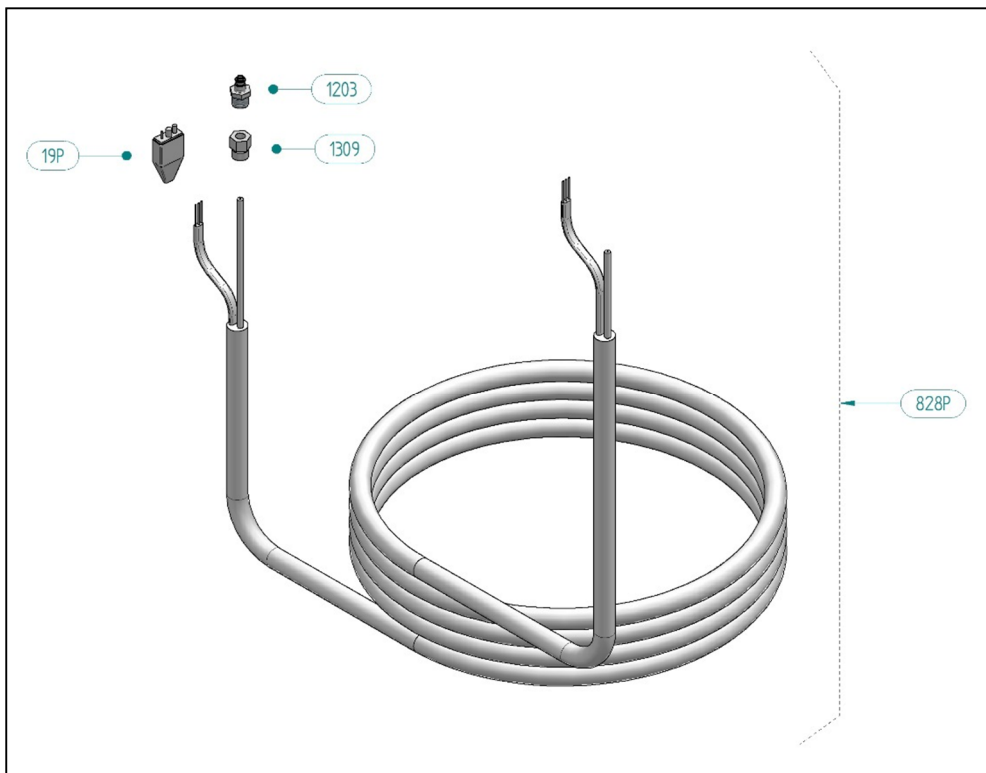
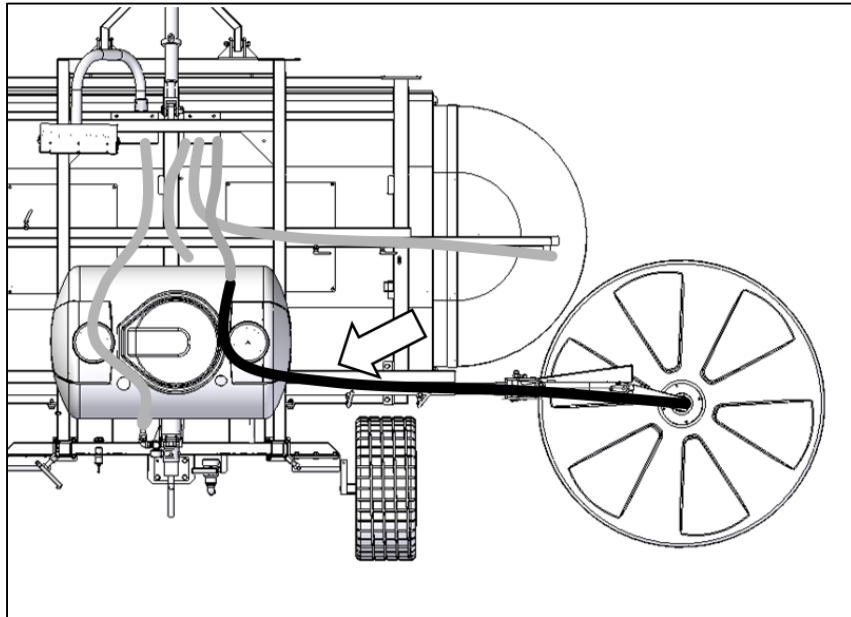

PART NO.	DESCRIPTION
19P	PLUG, 3 PIN, INLINE
828P	1200 DOME HOSE & CABLE ASSEMBLY, PART 2
1203	HOSE BARB, 1/4"
1309	ADAPTER 6 mm 1/4

- PUMP

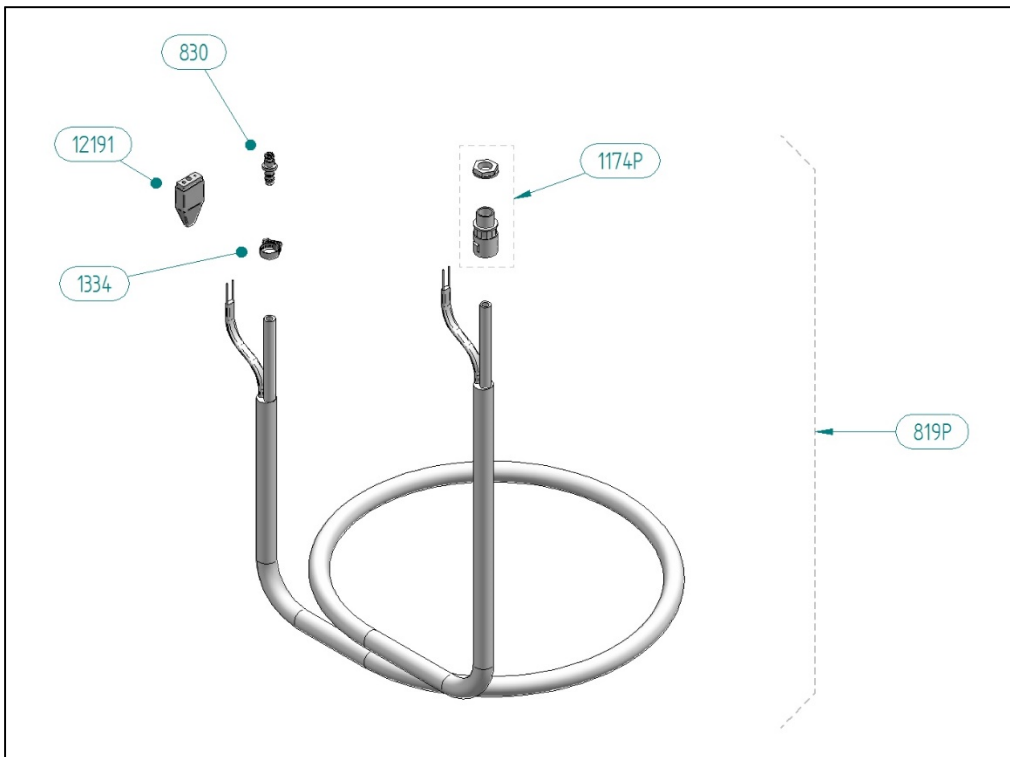
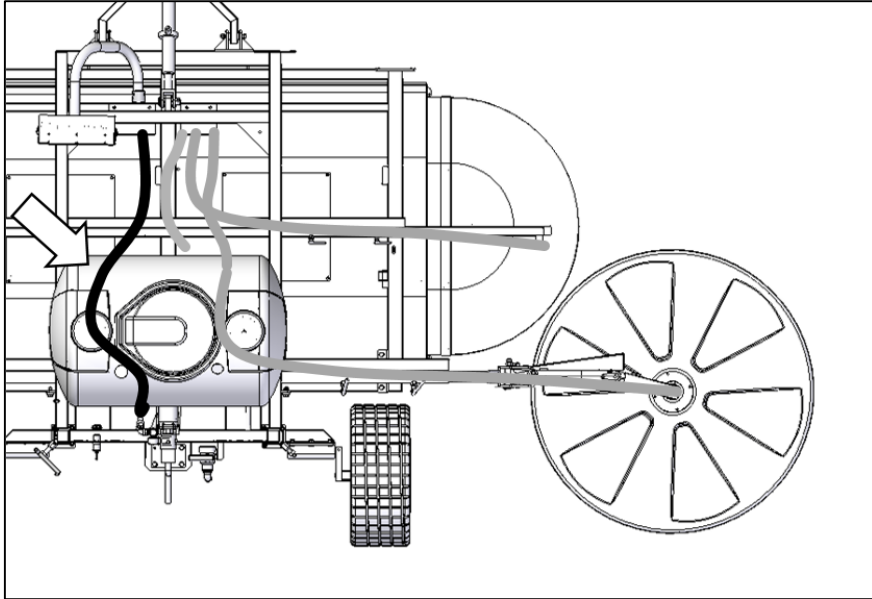

PART NO.	DESCRIPTION
819P	PUMP HOSE & CABLE ASSEMBLY
830	HOSE BARB, ¼" 8 mm
1334	CLAMP, 13-19 mm
1174P	M20 STRAIGHT FITTING
12191	SOCKET, 2 PIN, INLINE

- POWER WIRE ASSEMBLY

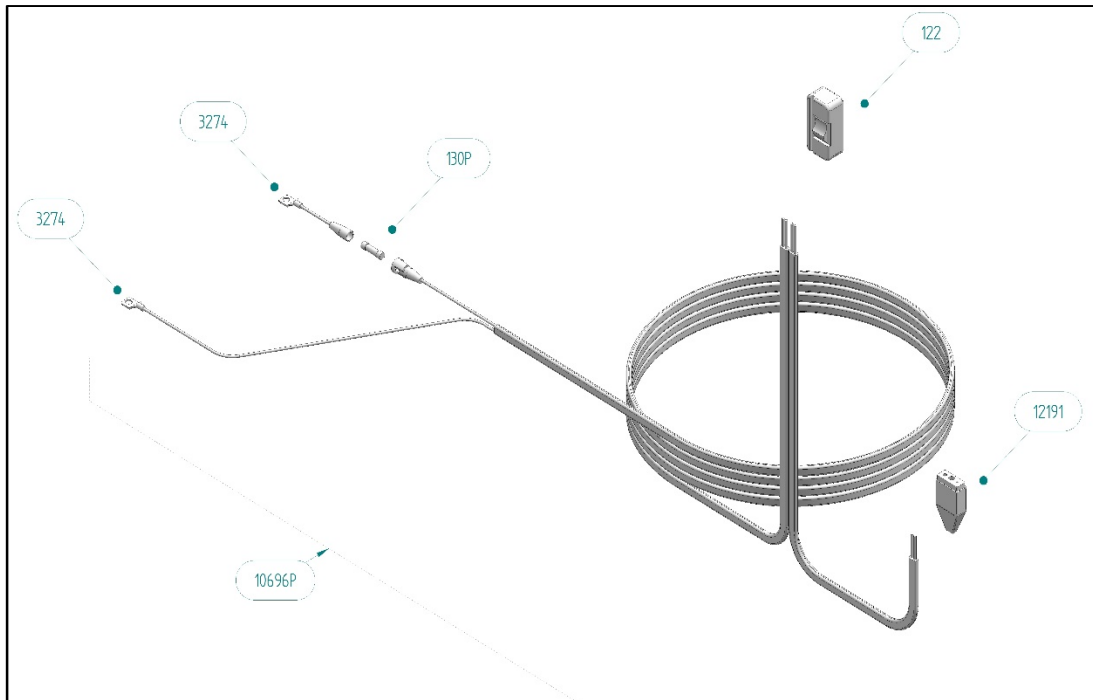

PART NO.	DESCRIPTION
122	SWITCH, INLINE
130P	FUSE, 10 A
3274	TERMINAL
10696P	POWER WIRE ASSEMBLY
12191	SOCKET, 2 PIN, INLINE