



robocrop inrow weeder

**Service Agent Guide
for In-Row Cultivation
Software Version 5.4.5
(With optional inter-row version 6.1.2
and optional thinning version 7.0.3)**

Disclaimer

Considerable effort has gone into making Robocrop reliable under normal commercial conditions. However, it is possible that under some adverse circumstances the guidance system will be unable to operate reliably. It is the operator's responsibility at all times to ensure that the machine is operating in a satisfactory manner. Should excessive crop damage occur operation should cease and if necessary your Garford dealer should be contacted for advice.

Contents

1. Preface.....	3
2. Safety.....	5
3. Assembly.....	6
Step 1 – Setting up the linkage arms.....	6
Step 2 – Reducing lateral movement.....	6
Step 3 – Levelling the implement.....	6
Step 4 – Connecting the hydraulic hoses.....	6
Step 5 – Mounting the console.....	6
Step 6 – Connecting the power supply.....	6
Step 7 – Connecting implement loom to the console.....	7
Step 8 – Starting the tractor and console.....	7
Step 9 – Checking hydraulic operation.....	8
4. Working screen – the basics.....	9
5. Getting to work in the field.....	11
Step 1 – Checking camera height and inclination in the field ..	11
Step 2 – Stationary alignment to crop rows.....	11
Step 3 – Initial running and adjusting camera lateral position ..	12
Step 4 – Running with rotary blades fitted.....	13
Step 5 – Setting camera height and inclination.....	14
Step 6 – Deriving new camera configuration figures ..	15
6. Notes on operation with a correctly set up machine.....	16
7. Information screens and menus.....	17
7.1 Working screen functions.....	17
7.2 Setup menu.....	18
7.3 Advanced set up & diagnostics menu.....	19
7.4 Configuration file editor.....	23
8. Maintenance and storage.....	30
9. USB Update and backup procedure (service menu).....	30
10. Troubleshooting.....	31
Annex 1 – Optional inter-row operation ..	37
Annex 2 – Thinning option ..	38

Copyright notice

The computer vision guidance software and the associated configuration tool on all Robocrop systems are copyright Tillett and Hague Technology Ltd.

This product also makes use of public domain operating system code. Under the terms of the GNU general public licence and/or the University of California, Berkeley (UCB) license copies of the public domain software are available on request.

1. Preface

Congratulations on purchasing a Robocrop precision guided implement.

The Robocrop precision within-row weeder is guided by a computer controlled steering system using video images to detect individual crop plants.

There are 5 main components to the system.

1. A video camera or cameras looking ahead at the area of crop to be cultivated.
2. An implement mounted computer system to analyse video images and control the system.
3. A cab mounted console to display user information including a live video image or images.
4. An automatic steering system to keep the camera(s) centrally over the crop rows and the implement precisely on track.
5. Hydraulically or electrically driven rotary cultivators to cultivate around crop plants within-the-row.

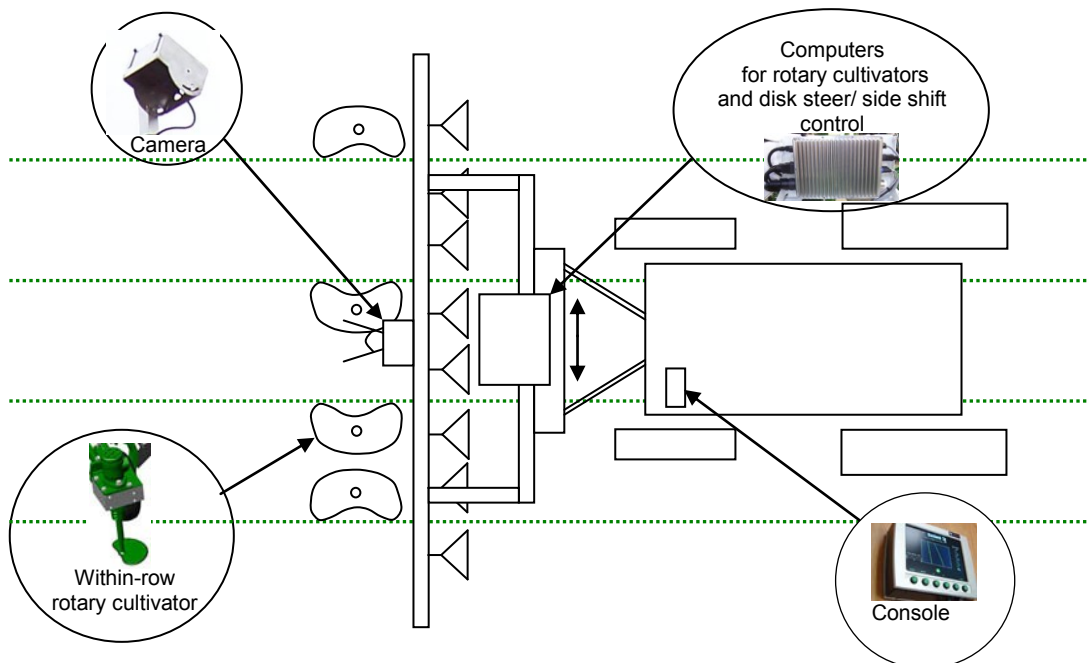

Schematic of a Robocrop front mounted within-row cultivator

With appropriate additional optional hardware it is also possible to configure machines to apply liquids as a spray or drench onto or between individual crop plants. This can be conducted with or without within-row cultivation.

Robocrop uses colour cameras to pick out green crop and weed from backgrounds containing soil, stones and trash. (Consult your Garford dealer for systems to work in red crops.) Robocrop locates crop plants within a scene by matching a template corresponding to the known planting pattern with crop plants as they appear in the camera image. These estimates of plant position are then used to synchronise the rotary in-row cultivation blades with the plants. The advanced template matching and tracking techniques used by Robocrop make it robust to moderate weed infestations. However, severe weed infestations may prevent reliable operation.

The within-row cultivation blades are based on a cut away disc designed to rotate about an axis offset from the crop row such that they cut into the row between plants but withdraw as they draw level with a plant. Disk profiles are designed to suit a particular planting pitch, though in practice one design can be used over a limited range of plant spacings.

Use of a camera to locate and track individual plants makes it possible to compensate for the normal variability of plant spacing by altering the speed of rotation of the rotary cultivation blades. The system will accommodate the within-row variability (typically +/-25%) to be expected from a well set up modern transplanter. In practice the largest variability in plant spacing is often due to hand gapping up after mechanical planting. Growers using a Robocrop in-row weeder may wish to consider briefing those people doing the hand gapping to take more trouble in achieving a uniform spacing.

The purpose of the working screen displayed on the console is to provide a graphic display of machine status. Graphical icons around the outside of the screen indicate important machine parameters and warnings. At the centre of the display is a live video image allowing the operator to correctly position the implement at the headland and to monitor the quality of plant tracking. As new plants appear at the top of the image green crosses representing plant position are initially placed over the image according to a predicted position based on the plants already located and the known planting pattern. Blue crosses indicating the best local match for plant position in that particular image are also displayed as an overlay (sometimes obscuring the green crosses). As plants progress down the image the green crosses represent a long term average of plant location based on several local matches of plant position through a sequence of images. By the bottom of the image the green crosses represent the final estimate of plant location and it is that position that is used to synchronise the rotary cultivators as the machine passes over the crop.

Machines with multiple cameras have live thumbnail video images across the top of the display. The user can toggle between each of these to select which is displayed full size.

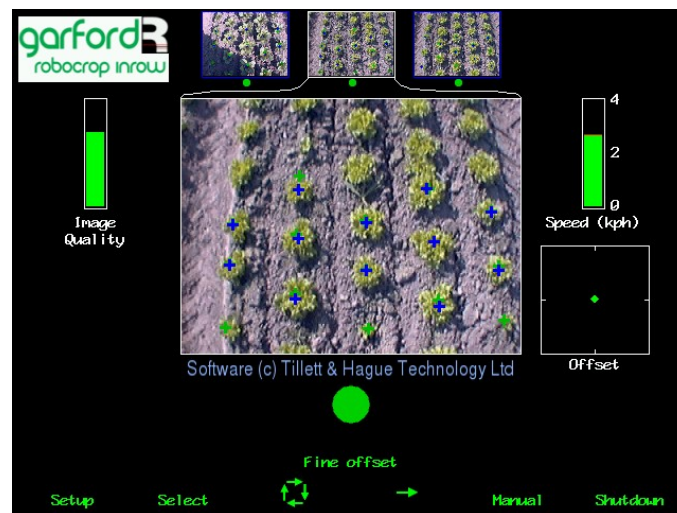

Typical working screen for a three camera system with estimated plant locations overlaid as green crosses and spot measurements of individual plant positions as blue crosses.

Matching a template over a number of rows and looking ahead to a number of plants within-the-row improves reliability over systems based on simpler sensor systems, especially when weeds might be confused with crop plants. Template shape is determined by a configuration file pre-programmed to suit a particular crop planting geometry and implement configuration. Different configuration files are available from your Garford dealer for different crops and implements.

An accurate match between the template and crop rows is important for accurate cultivation.

Disclaimer

Considerable effort has gone into making Robocrop reliable under normal commercial conditions. However, it is possible that under some adverse circumstances the guidance system will be unable to operate reliably. It is the operator's responsibility at all times to ensure that the machine is operating in a satisfactory manner. Should excessive crop damage occur operation should cease and if necessary your Garford dealer should be contacted for advice.

2. Safety

1. When carrying out repairs or adjustments to a side shift, steering discs, rotary blade units or implement, ensure that the Robocrop system is switched off and that the hydraulic supply is off. It is also necessary to ensure that the hydraulic accumulator is fully discharged as this component stores oil under pressure and could power movement even with the tractor hydraulic supply disconnected. Operators of machines with electric rotors should ensure that the electrical power pack is isolated
2. Never conduct maintenance work on the side shift or disk steering mechanisms while they are supporting the implement.
3. The side shift and steered disc mechanisms form pinch, trap and shear points. Be aware of these when carrying out maintenance.
4. Regularly check the condition of electric cables, hydraulic hoses and fittings.
5. The hydraulic supply manifold is fitted with a hydraulic accumulator. Discharge the accumulator before disconnecting from the tractor.
6. Do not allow other persons to ride on or work near the implement when it is in operation.
7. The 12V power supply cable has a 20Amp fuse fitted near to the battery terminals. This is for short circuit protection and must not be omitted.
8. When routing the loom and power supply cables ensure that they do not cause a restriction or trip point in the cab.

Note:

Hydraulically driven in-row rotors have been designed to operate using closed centre hydraulic systems that supply flow on demand. The machine will function with open centre hydraulic systems, but the supply of full flow at full system pressure will be energy inefficient and may result in the generation of excessive heat. If the operator chooses to operate In-row Robocrop with an open centre system then it is their responsibility to monitor hydraulic oil temperature. Robocrop's valves should not be operated with oil above 70 degrees centigrade. Operators should consult the tractor manual for any limitations relating to tractor systems. The generation of heat can be reduced by turning the hydraulic supply off when not required. Garfords can supply a purpose designed PTO driven hydraulic power pack if the tractor's hydraulic system is not appropriate.

3. Assembly

The following steps outline how the Robocrop precision guided implement should be set up.

Step 1 – Hitching to the tractor

Position the tractor and implement on a level surface. Check that the tractor's lower link arms are evenly adjusted and hitch the tractor to the 3 point linkage points on the side shift frame.

Caution

- The side shift 3 point linkage points are to standard category 2 dimensions and so must be attached to a similar tractor linkage.
- Once the 3 point linkage is correctly fitted stop the tractor and apply the handbrake.

Step 2 – Reducing lateral movement

Adjust the stabiliser links to prevent lateral movement of the lower link arms.

Caution

- For side shifting front mounted systems it is particularly important that there is no lateral movement in the linkage.

Step 3 – Levelling the implement

With the cultivator on the ground, adjust the top link so that the cultivator is level, front to rear (camera pole(s) should be vertical).

The control system loom and hydraulic hoses can now be routed from the implement to the tractor.

Caution

- Clipping the loom and hoses to the top link should keep them clear of catch points.
- Make sure that the linkage can be operated over its full range without stretching or chaffing the loom conduit or hoses.

Step 4 – Connecting the hydraulic hoses

Plug the hoses into a suitable double acting valve connection on the tractor or auxiliary hydraulic power system. Markers on the hoses indicate the following:

Supply – **RED** Return - **BLUE**.

It is important to regularly check that the implements hydraulic filter has not become clogged by checking the indicator at the top of the filter.

Step 5 - Mounting the console

Mount the console in the tractor cab in a position where it can be clearly seen but does not obscure operator's visibility. Four screws (M6 x 12) and tapped holes in the rear of the console facilitate mounting to a bracket. Use of a suction bracket for mounting on the tractor wind screen is convenient and provides good vibration isolation. However, these can become unstuck, especially on curved glass and so it is important to secure the safety leash provided. An alternative vibration isolated mounting onto round bars is also available.

Caution

- The console should be protected from severe vibration.
- Do not use longer screws than those supplied otherwise damage to the console may result!

Step 6 – Connecting the power supply

The 12V power supply cables from both the implement mounted control box and the cab mounted console should be connected directly to the tractor battery or via purpose designed power sockets. Cigarette lighter sockets are not suitable.

For machines with electric rotors the 36V electrical power pack should be connected to the implement with the cable provided.

Caution

- Route the cables carefully ensuring that they cannot become trapped or chaffed.
- The 20amp fuse at the battery terminal end of the 12V cable is for short circuit protection and must not be removed.
- The polarity is denoted by + and – marker rings on the cables. The fuse is on the + cable.

Step 7 – Connecting the implement loom to the console

The loom from the implement should be routed into the tractor cab and through to the console.

Caution

- Do not to allow the loom to restrict access to or exit from the cab or act as a trip point.

Plug the large multi pin plug into the socket in the bottom of the console.

Caution

- Note the correct alignment of the tabs in the plug and socket and avoid excessive force in pushing the connector together. **If you have any problems with this connector consult your dealer as incorrect assembly will seriously damage the computer.**

Ensure alignment tabs and slots are lined up when inserting the plug into the socket

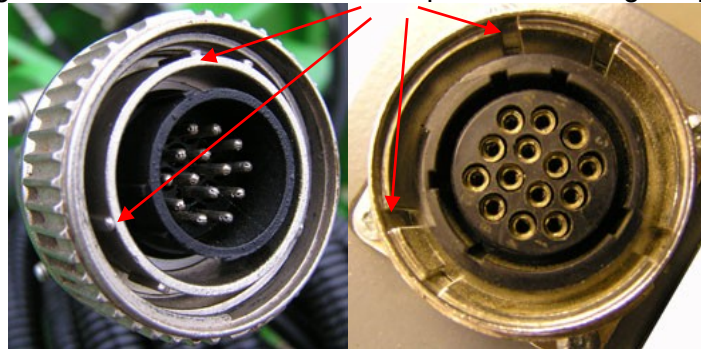

Step 8 – Start up and rotor unit start up test

With the implement still on the ground check that the spool valve is in neutral and all persons are well clear. Start the tractor and switch on the console. Wait for the system to "boot up". After a few screens of familiar PC boot up text a screen will be displayed prompting you to lift the implement. Having done so you will see the message, "Ensure all personnel are clear of the machine", with the option to begin the start up testing process. Having checked that the area is clear, set the tractors hydraulic control to provide a constant flow to the implement, ensuring that you have the facility to disengage the hydraulic supply immediately should a fault occur. For electric rotors turn on the 36V electrical supply.

To initiate the start up test process press the button labelled "begin" at the bottom of the display. The screen will for the next 15 seconds display the message "Synchronising encoders" during which time the rotor units should all rotate. They should ramp up in speed holding at a constant speed for 5 seconds and then ramp down again. If this self testing process has a satisfactory outcome the working screen will be displayed and the side shift or steering discs will centralise if they were not already centred.

If the self test process did not produce a satisfactory outcome an appropriate message will be displayed to help diagnose the problem. These potential messages include "No rotation?", "Reverse rotation (Rotor No)" and "Coms fail." The user has the option via labelled buttons to "Ignore" the result and continue to the working screen, "Retry" the test process, or "Shutdown". The message "No rotation" may indicate that the hydraulic oil supply is not reaching the implement or that it is set at a very low flow rate or for electric rotors that the electrical supply is off. "Reverse rotation" would indicate that the pipes to the specified hydraulic motors should be reversed. If all the rotary units are specified it may be that the main hydraulic supply is connected incorrectly. Electric rotors should not produce the "reverse rotation" message as that would indicate a wiring error. The message "Coms fail" refers to an internal problem with a microcontroller connection. If you get a "Coms fail" message power the system down completely and try again. If the problem persists contact your Garford Dealer.

Step 9 – Checking hydraulic side shift/disc steer operation

With the tractor running, the implement lifted and the console displaying the working screen the side shift/steering discs should have automatically centred.

If the side shift or discs were already central and you wish to test them press the second button from the left on the bottom of the console (labelled “manual” on the working screen). The hydraulic side shift/steering is now in manual mode and can be operated via the third and fourth buttons (labelled with left and right arrows on the working screen). Each press of a button steps the side shift/steering by about 11mm/3.5° of its stroke. Repeated pressing (but not holding the key down) will result in continuous travel up to the end of the stroke. This procedure can be used to check that hydraulic flow is in the correct direction and that the side shift rate is correct. A normal side shift rate would be 0.1m/s (e.g. 3s to travel a 0.3m stroke). To return to normal automatic mode press the same button (now with “manual” highlighted) again. The side shift/disc will stay in the position it was placed under manual control until the implement is lowered and raised again, or the machine starts to travel forward.

Caution

- Side shift/disc travel all the way to one side on lifting the implement may indicate that the hydraulic supply to the control valve is connected the wrong way.
- Rapid side shift/disc oscillations back and forth about the central position indicate that the hydraulic flow rate to the side shift is too high. To reduce the flow the hydraulic flow control valves on the implement may be adjusted, see picture of valve below with cover removed.
- Only adjust the flow control valve with the implement on the ground and the tractor engine switched off.

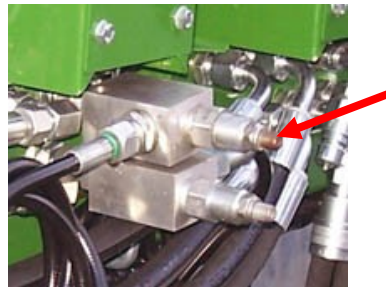

The machine is now ready for work, though before proceeding to the operational phase it is worth familiarising yourself with the working screen.

4. Working screen – the basics

On start up after completing the initial rotary unit tests the console displays the working screen as illustrated below. It has the following features:

- A live camera video image in the centre of the screen. Superimposed over the live video image are two arrays of crosses green and blue. Green crosses represent the estimated position of individual crop plants. They are initially placed near the top of the image according to nominal plant spacing and estimated position of previous plants in that row. They should therefore be close to, but not necessarily exactly aligned with actual plants in the video image. As they progress down the image observations from successive images (blue crosses) are used to refine this initial estimate so that by the time they reach the bottom of the image they should accurately reflect plant position. It is the last estimate of plant position as they leave the bottom of the image that is used to synchronise rotary disc units or nozzles.

The blue crosses (superimposed over the green crosses) represent the best fit for the individual plant matching template in that image for that particular plant. These observations are combined with previous estimates to refine that location. If individual plant matching templates cannot produce a good match, the crosses will be displayed as yellow or red. An image with a high proportion of red or yellow crosses is likely to lead to poor tracking. Steps should be taken to improve the situation and cultivation should only proceed with caution.

- Systems operating with multiple cameras will display live thumbnail video along the top of the display. The button labelled “select” toggles between thumbnails for full size display.
- An image quality gauge to the left of the screen giving a relative indication of likely tracking performance based on a combination of all images. The higher the green bar the better. A low bar indicates either a poor template match or poorly defined plants in the video image. Robocrop will under most circumstances operate down to an indication of approximately 20% albeit at reduced accuracy.
- An area just below the image quality gauge is reserved for graphics indicating machine status.

If the implement is lifted a graphic of a lifted hitch is displayed.



If the implement is stationary a red brake graphic is displayed



A warning triangle indicates poor tracking. If it is displayed with a horizontal double headed arrow Robocrop estimates that the error in lateral implement position exceeds 25mm. If the arrow is vertical Robocrop estimates the phase angle error of at least one of the rotor units exceeds 15°. On seeing this warning users should slow down or stop and check performance on the ground.



- A speed gauge on the right shows forward speed and should match tractor speed. The speed bar is normally green, an amber section indicates the machine is operating at over 75% of maximum speed and a red section indicates over speeding (as illustrated below).
- A spray pressure gauge displays system pressure if spray nozzles are configured. (not shown)
- A green dot and green chevrons below the image indicate side shift/slide position. A red chevron with a vertical bar indicates the limit of travel has been reached. This should not be allowed to occur for extended periods.
- The fine offset gauge shows the amount of left, right, forward or backward bias set by the user. This is used to compensate for minor lateral camera misalignment, but the lateral fine offset can also be useful on side slopes. The fore and aft fine offset alters the phase relationship between the rotary units (and nozzle timing) and the crop plants. It applies equally to all rotary units (and nozzles) in that view. See section 7.1 for how to adjust the fine offset. For multi camera systems fore and aft fine offset relates to the rows associated with the image selected for full size display. For independently steered multi section systems the lateral fine offset is also associated with the image selected.

Operator controls are via 6 buttons located along the base of the display screen. These are known as soft keys because their function changes depending on the screen being viewed. Soft key 1 (Sk1) is on the left and soft key 6 (Sk6) is on the right. Current soft key function is indicated immediately above the button on the display screen. A full description of these functions is given in section 7 page16.

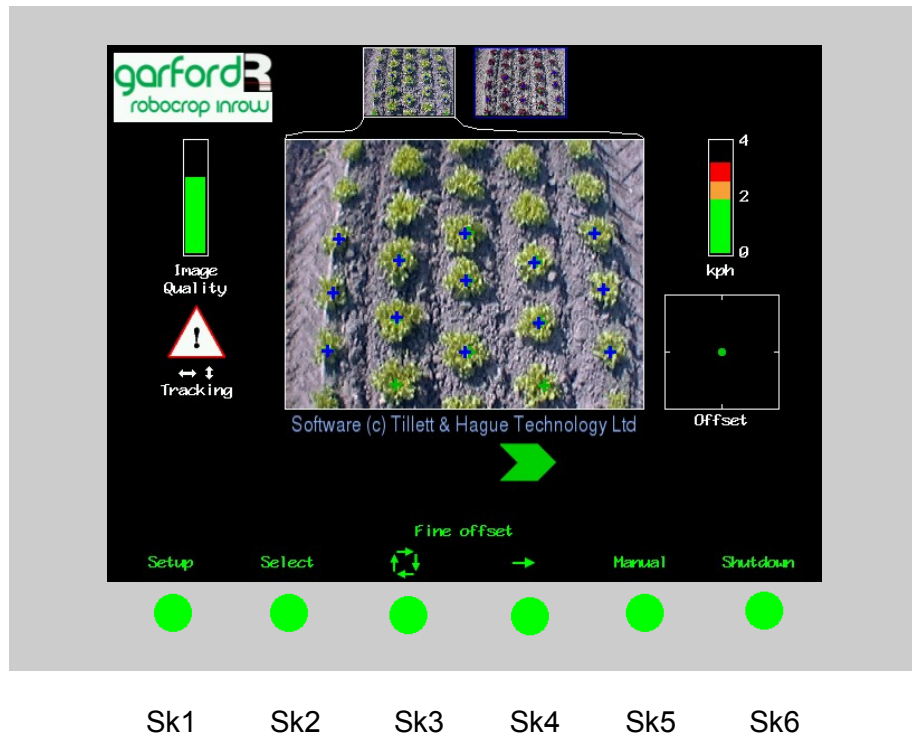

An area of display towards the bottom left corner is reserved for system warning messages:



Indicates either processor or auxiliary fans in the control module have stopped

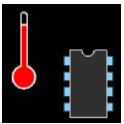

Indicates control module processor is overheating

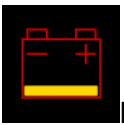

Indicates low voltage power supply (for electric rotors only)

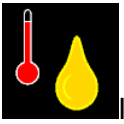

Indicates high oil temperature $>70^{\circ}$ (if condition monitoring fitted), **operation should be stopped immediately to prevent irreversible valve damage**



Indicates low hydraulic oil pressure <100 bar (if condition monitoring fitted)



Indicates pressure in hydraulic tank line (if condition monitoring fitted)



Indicates blocked oil filter (if condition monitoring fitted), **stop operation immediately and change filter**

5. Getting to work in the field

The most important procedure to ensure good guidance is to match the template representing the expected planting pattern with the crop plants as they appear in the live video image. The following steps outline how to get the best match and hence good guidance.

Tip: For the first few hundred meters of running after commissioning Robocrop learns a term known as camera skew (see section 7.3) Camera skew compensates for minor errors in camera orientation in the horizontal plane. Wherever possible we recommend that set up runs (steps 3 & 4) are conducted in crop showing the clearest rows available at the time so that camera skew is learned as quickly and accurately as possible. High visibility rows also help manual alignment checks (step 2). We also recommend that side slopes and intense partial shadows are avoided during initial running. Once set up is complete more challenging situations can be tackled.

Step 1 – Selecting configuration file and crop size

From the working screen press button Sk1 labelled setup. This switches the display to the setup screen.

The top line of this screen indicates crop size (height) settings under categories of small (5cm) medium (10cm) and large (20cm). Ensure that the highlighted option corresponds to the crop being used for setup and initial running.

Check the detail at the bottom of the screen to ensure that the configuration file settings selected matches crop and camera geometry. Check also that the disc size setting matches the disc fitted and that the actual minimum plant spacing is not less than the disc size. (Plant spacing < 85% of disc size risks plant damage, a plant spacing < 67% of disc size will cause the tracking to “drop” one of the adjacent plants so it is thinned out.)

If configuration settings are not correct refer to section 7 for instructions on making the necessary changes.

To return to the working screen press Sk6 labelled “OK”.

Step 2 – Checking camera height and inclination angle in the field

Draw into a field and set the cultivator down onto a typical section of crop. The cultivator should be set onto the rows as accurately, and as straight as possible.

Press Sk5 labelled “Manual”, The overlaid green lines representing the template of the expected planting pattern should lock in the centre of the screen.

Caution: If the overlaid green lines are not symmetrical on the screen (by more than 4 degrees) the camera skew value may require investigation. Refer to the advanced set up & diagnostics menu in section 7.3.

The green lines superimposed over the live image should align with the crop rows as illustrated below. For best results there should be at least 1/4 of a row spacing between the edge of the image and the outer rows at the bottom of the image. The rotor units should also be close to, but just out of view at the bottom of the image. If either of these is not the case please consult your Garford dealer.

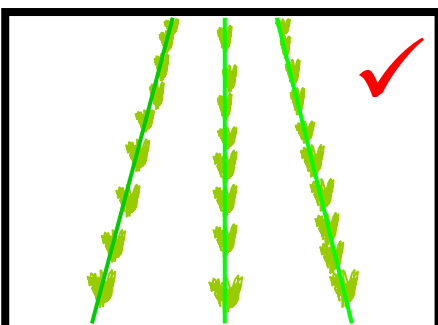

If the template is parallel to, but narrower or wider than the crop rows, check that the correct crop size has been selected. If the crop setting is correct then either the camera height, or the value given in the configuration file (displayed on the set up screen), will need adjusting. Please consult your Garford dealer. (The procedure for physically setting camera height and inclination for a given configuration are given in step 5 and the procedure for creating a new configuration is given in step 6.)

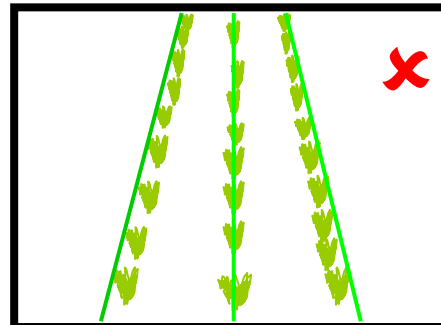
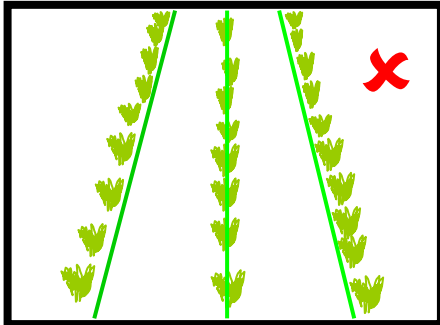

If the template matches at the top of the screen but not at the bottom, or vice versa, check that the implement is set horizontal. (The top link should not be used as a method of controlling cultivator depth). If the implement is horizontal then either the camera angle to the vertical or the values of camera height or look ahead in the configuration file (as displayed on the set up screen) need to be adjusted. Please consult your Garford dealer. (The procedure for setting camera height and inclination for a given configuration are given in step 5 and the procedure for creating a new configuration is given in step 6.)

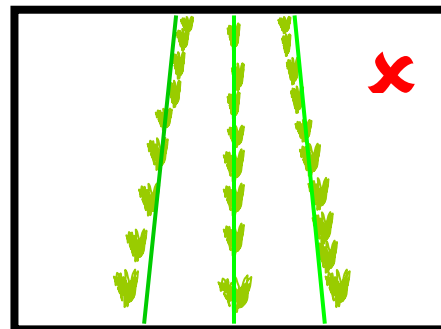
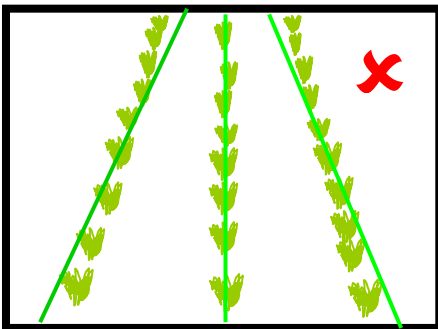

Good tracking will only be achieved if the template lines are centred on all of the rows being tracked.

The superimposed green grid lines also have tick marks (not shown in the illustrations above) corresponding to the nominal plant spacing corrected for perspective. Whilst the tick marks should not be expected to align with specific plants, the space between ticks should approximately correspond to the distance between plants as they appear in that area of the image. If after allowing for normal variability the plant spacing do not match up to the tick marks the nominal plant spacing set in the configuration file (displayed on the set up screen) should be re checked against actual spacing on the ground and if necessary changed (see section 7).

For multi camera systems Step 2 should be repeated for each camera (use Sk2 "Select" to toggle between cameras)

Step 3 – Initial running and adjusting camera lateral position

When you are happy you have a good template match press the button labelled "Manual" again to return to the normal working screen ready for tracking. You can be sure that the machine is ready for tracking if an array of blue and green crosses have appeared corresponding plants as they appear on the display.

Tip: In order simplify the set up procedure it is suggested that **initial running is conducted with the rotary cultivation blades removed**. This allows the operator to concentrate on inter-row cultivation and lateral alignment before introducing within-row cultivation.

Note: For initial set up runs almost all the crosses should be coloured green or blue and form a relatively straight lines corresponding to the crop rows. If this is not the case, or a triangular tracking warning symbol is displayed, either the machine is not correctly set up, or the crop rows are not sufficiently well defined for initial running.

If tracking appears good set off slowly into the crop. The implement should quickly align with crop rows. It is likely that after a short distance it will have settled at a small lateral offset. Small offsets can be corrected using the fine offset facility available from the working screen (see section 7.1). Each press of a left or right arrow key biases the side shift in steps by 1cm (3/8"). Continue down the field stopping occasionally to check lateral position. If the required fine offset exceeds the available number of steps the camera should be physically moved as described below and step 4 repeated. For independently steered multi section machines each section must be checked.

After approximately 200m of running Robocrop should have learnt camera alignment and lateral bias should therefore have stabilised. If the fine offset is set to greater than two steps we recommend physically moving the camera along the toolframe by the equivalent distance and resetting the fine offset to zero. Where multiple cameras are fitted on a single section all should be moved by the same amount.

Tip: If the fine offset is set to the left then the camera(s) should be moved to the right as viewed from behind looking forward.

Step 4 – Running with rotary blades fitted

Once you are confident that Robocrop is tracking laterally accurately and reliably the rotary blades appropriate for the nominal within-row plant spacing can be fitted.

It is important that the rotor units are correctly aligned laterally with respect to the crop rows. In general blades designed for salad crops (part no: disc size _ 4_W_X) should be set with the centre of rotation offset 4cm from the crop row at ground level. For blades designed for larger crop plants such as brassicas (part no: disc size _ 6_W_X) the lateral offset should be 6cm.

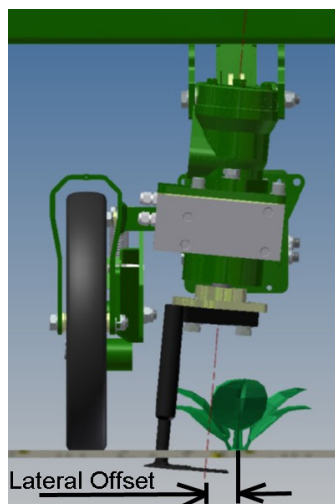

Ensure that the fine offset position in the fore and aft direction is central (see section 7.1) and place the implement down so that the rotary blades are at least two plant pitches behind the first plant. Failure to observe this may result in damage to the first plant in each row as the system may not have time to synchronise.

Set off at low speed. After the first few plants have been passed the accuracy of cultivation around plants should be examined. If the cultivators are consistently cultivating around a point that is ahead of crop plants the fine offset should be moved down using the down arrow. Each button press corresponds to 1cm (3/8") of phase shift. Similarly if the rotary cultivators are cultivating about a point behind the plants the up arrow should be used (see diagram below).

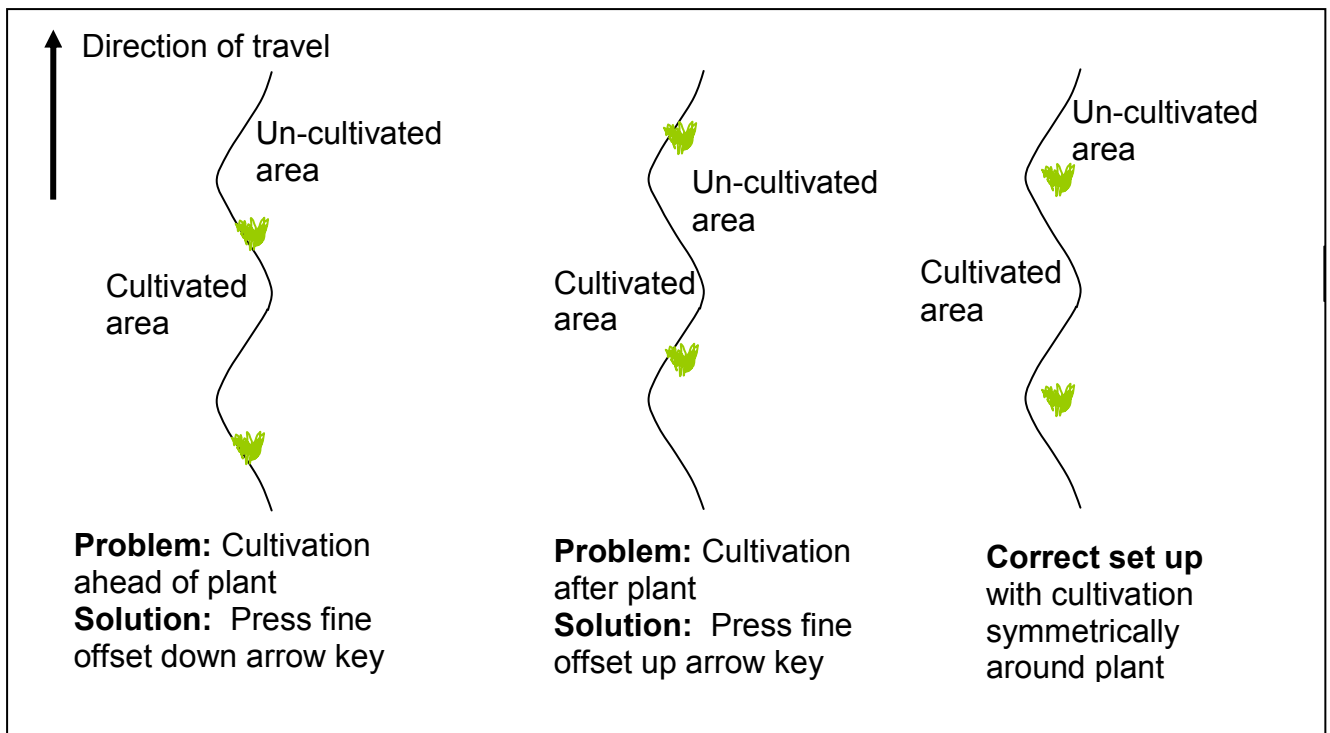

Illustration of how to use fine offset to match the centre of cultivation with crop plants

Multiple camera systems require fore and aft offset to be checked separately for each camera and its associated rotors.

Once you are confident that Robocrop is tracking accurately and reliably, both laterally and fore and aft, forward speed can be increased. The upper recommended linear speed can be obtained by multiplying the upper recommended rotary speed (3 revs/s) by disc size (as displayed at the bottom of the set up screen), thus for a 40cm disc the nominal maximum speed is 1.2m/s (4.3kph). For a disc size of 20cm the nominal maximum is 0.6m/s (2.2kph). Rotors will rotate at much higher speeds and accurate control will be maintained up to 4 rev/s. However in most cases the maximum forward speed will be limited by the mechanical effect of cultivators on the soil and its effect upon plants. Excessive speed will be shown as a red section on the normally green or orange speed bar and is likely to result in a tracking warning in the fore and aft direction. Should that occur the speed should be reduced to a safe level below that at which the warning appears.

It is the operator's responsibility to decide at which point the vision guidance system becomes 'lost'. If the system losses track of crop plants the operator should cease cultivation and seek to establish the cause of the problem. If necessary your Garford dealer should be consulted for advice.

Garford accept no responsibility for damage to or loss of crop whatsoever.

If satisfactory tracking both between and along rows has been achieved steps 5 and 6 can be omitted and the machine is ready for use.

Step 5 – Setting camera height and inclination (for a given configuration)

Note: Camera height and inclination will normally be factory set and should not require adjustment. However, should adjustment be necessary, due to accidental damage etc, the following instructions should return the system to its original factory state.

Set the implement down onto a flat surface so that it is resting on its depth wheels at its normal working height. (If the implement is disc steered ensure that the disc flanges are not preventing it from settling to its working depth.)

It is important that the top link is set to make the cultivator horizontal when in its working position.

Select the set up screen and note the figure for “Camera height”. Now adjust the camera height (measured to the centre of the lens) above ground level so that it matches this figure.

Using a plumb or spirit level mark the point on the ground vertically below the camera (centre of lens). Measure forward from this point along the ground by the “camera look ahead” on the set up screen. Mark this position in such a way that it can be seen in the live video image.

Next return to the working screen and press the button labelled “Manual”. A set of green lines and a central set of cross hairs will be superimposed over the live video image. Adjust the camera inclination (angle to the vertical) so that the cross hairs coincide with the mark on the ground.

Note When you are satisfied that both height and look ahead distances are correct ensure that all clamping bolts are tight as even small movements in camera position will have significant effects on rotor synchronisation with plants.

Step 6 – Deriving new camera configuration figures (required only after hardware changes)

Adjust the height of the camera so that all the crop rows are in view at the bottom of the image with at least a half row spacing clear on either side. The inclination of the camera should now be adjusted so that the bottom of the field of view is close to, but not actually showing the rotary cultivator units. As these two adjustments interact it may be necessary to repeat these procedures until both conditions are satisfied.

It is now necessary to make two measurements. First, the height of the camera (centre of lens) above ground level. Secondly, the distance along the ground from the centre of the image (defined by cross hairs superimposed on the live image when in manual mode) and a point vertically under the camera (centre of lens). These two dimensions should then be entered into the configuration file as “Camera height” and “camera look ahead” respectively. Your Garford dealer would normally do this for you, but experienced users can enter their own figures using the editor as described in section 7.4.

If the machine has more than one camera the process should be repeated for each camera.

6. Notes on daily operation with a correctly set up machine

- Before operation check that electrical and hydraulic connections are secure and that there are no obstructions to side shift/disc movement. Check also that the implement hydraulic filter indicator does not show that the filter is clogged. Clogged filters should be replaced before working and repeated clogging investigated as it indicates high levels of contamination that may cause expensive components to be irreparably damaged.
- On first setting the implement down in the field check for each camera that the green and blue crosses line up with crop plants and form relatively straight lines corresponding to crop rows. There should be few yellow or red crosses.
- Proceed with caution for first few meters checking that Robocrop's speed gauge matches the tractors and that implement alignment is good. If performance is satisfactory speed can be increased. Robocrop's within-row tracking should be very good at linear speeds of up to 3 (rev/s) times disc size (e.g. 3 rev/s x 0.3m = 0.9 m/s =3.2 kph). Robocrops rotors should remain synchronised with plants at up to 4 rev/s, though in practice plant spacing variability and soil movement considerations may dictate a lower operating speed.
- Robocrop remembers the fine offset settings from previous sessions and so there should not normally be any need to adjust this unless changes have been made to camera position.
- Operating on side slopes will result in some lateral error due to the tractor "crabbing" across the slope. Normally this is not significant, but in extreme cases it may be necessary to use the fine offset function to compensate. If operating in this way remember to reverse the bias when heading in the opposite direction and to return to a neutral setting when stopping work or moving to a flat area. A similar technique can be used to compensate for crop bent laterally by a cross wind.
- Each time the implement is lifted at row ends it will centralise ready for the next run.
- At the end of the day shut down the system by pressing the button on the far right (SK6) labelled 'Shutdown' and wait until the report 'system halted' is displayed, then switch off the power. It is also advisable to discharge the hydraulic accumulator by reversing the tractor hydraulic supply spool briefly. The implements pressure gauge indicates if this has been achieved.

If in doubt about any machine settings or operating procedures please contact Garford Farm Machinery on +44 (0)1778 342642.

7. Information screens and menus

Robocrop has a graphical working screen that conveys all the information necessary for normal operation. A description of this screen is given in section 4.

A series of six buttons along the bottom of the display allow the operator to access user controls such as fine offset and manual control of side shift/steered discs. The function of these buttons is described by labels on the video screen immediately above each button.

Set up procedures and more advanced information can be accessed via additional screens that can be navigated to via the working screen. The function of the six buttons below the display, known as soft keys, changes with each screen, but is always described by the label displayed above.

7.1 Working screen functions (see section 4 for an explanation of the graphics)

Sk1 Labelled “**Setup**” this button accesses the setup menu (section 7.2).

Sk2 Labelled “**Select**” on multi camera systems and blank for single camera systems. This button toggles between cameras affecting the main image displayed and the context of the fine offset.

Sk3 Repeated pressing of this button changes the function of Sk4 from left, right, fore and aft arrows as required to alter the fine offset. (Except in manual mode when this button moves the side shift/steered discs left in steps)

Sk4 Moves fine offset in the direction of the arrow selected (using Sk3). Both lateral steps and fore and aft movements are in 1cm increments. (Except in manual mode when this button moves the side shift/steered discs right in steps) For multiple camera systems the fore and aft fine offset relates to the rotors associated with the camera selected for main display.

Sk5 Labelled “**Manual**” this button switches the system into manual mode. It disables the vision system and allows the user to move the side shift/steered discs left or right manually in steps of 3.5% of potentiometer stroke for each press of Sk3 or Sk4. To prevent mechanical damage this function only operates when the implement is lifted.

This button also locks the green lines representing the template of the expected planting pattern centrally in the picture whilst retaining a live video image. This is useful when making camera adjustments to match crop rows with the template.

Pressing the button again resumes normal vision guidance. The side shift/discs remain in the position they were placed manually until forward movement under vision guidance is commenced, or an implement lift is detected. The later will centralise the side shift/discs. Manual mode is exited automatically if the implement starts moving.

Sk6 Pressing this button labelled “**Shutdown**” enters a shut down screen from which you can elect to continue with the shut down process by operating SK5, labelled “exit”. Wait until the script says ‘system halted’ then turn off the main power switch.

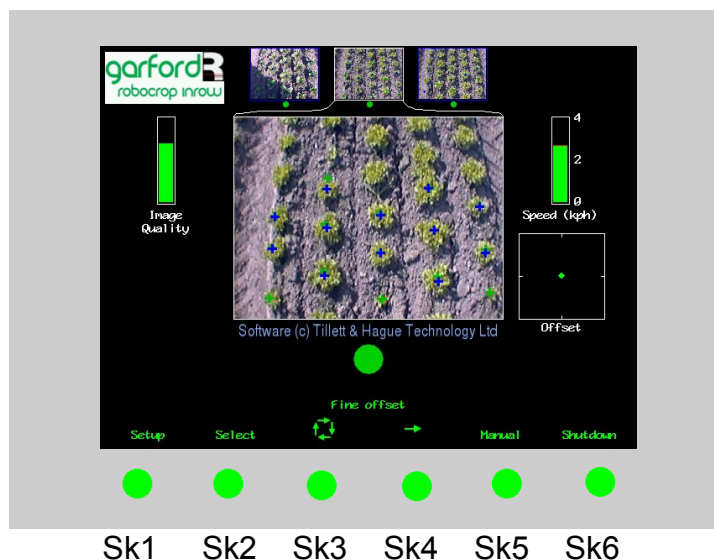

7.2 The Setup Menu

The setup screen can be reached by pressing the appropriate button (Sk1) from the working screen. “Crop size”, “Configuration”, “Clearance” and “Crop colour” can be selected in the Setup menu. It is also possible to adjust, within limits, plant spacing from the configuration file value.

Navigation within the set up screen is achieved by moving the cursor over options using buttons labelled with arrows (Sk2-Sk4). When the cursor is over an appropriate setting it can be selected by pressing the button labelled “OK” (Sk6)

“**Crop size**” increases template size to compensate for the crop canopy getting closer to the camera as it grows. This avoids physically adjusting camera height when moving between crops of different heights. Robocrop has settings for small, medium and large crops. As a guide, crops up to approximately 5cm (2”) high are regarded as small, 5cm (2”) to 10cm (4”), medium and greater than 10cm (4”) high, large. On initial set up the default will be medium, though Robocrop remembers crop size from the previous session regardless of which configuration file was used.

“**Configuration**” allows the user to select between alternative pre-programmed configuration files when going to work on crops with different planting geometries requiring different templates.

The main parameters of the chosen configuration file are displayed below, they are:

Camera number (and type, e.g. colour or IR)

Viewing - No of rows used for tracking, Spacing - spacing between rows being viewed.

Height - Distance vertically from lens to ground when in work

Look ahead – Horizontal distance in the ground plane between a point vertically below the camera lens forward to the centreline of sight (cross hairs in “Manual” image).

Ahead of rotors by - Horizontal distance between a point vertically below the camera lens back to the rotors. (If the camera is mounted behind the rotors this figure is negative)

Disc size – A parameter relating to disc geometry available from Garfords.

“**Plant spacing**” – Nominal spacing between plants within-the-row. With the cursor over this value the spacing can be incremented or decremented in steps of 2.5cm (1”)

“**Clearance**” (optional facility) – Enables the rotor disc to cut slightly closer or further from the plant than normal

“**Crop colour**” (optional facility) – For green crops select “Green”. Selecting “Red” inverts colour segmentation so that red rather than green plants are tracked. For plants with a combination of red and green foliage select “IR” and change the camera filter for an opaque infra-red pass filter.

If a suitable configuration is not available this can be created. We recommend that customers ask their Garford distributor to produce an appropriate configuration file. However, experienced users can use the configuration file editor (section 7.4) to create their own.

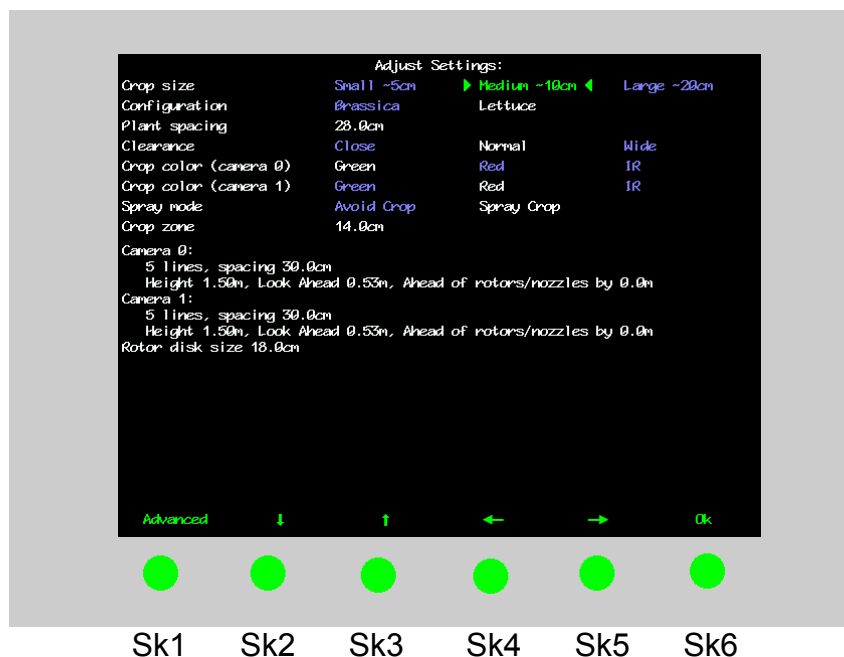

7.3 Advanced set up & diagnostics menu

This screen is intended for advanced users only. It is reached from the set up screen by pressing button Sk1. Navigation within this screen is similar to that used in the set up screen.

The first four items on this screen are for information only and cannot be changed by the user. Area worked is based on distance x width.

The remaining items on this screen are as follows:

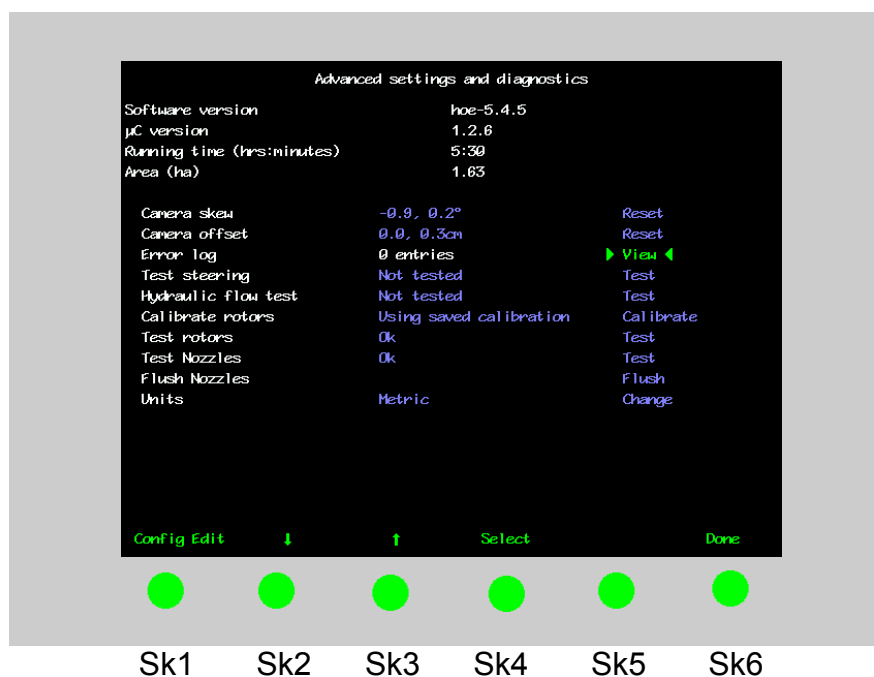

Camera skew

Camera skew is a measure of camera angular misalignment in the horizontal plane. This angle is estimated by Robocrop's computer programme during field operations. Rate of change is highest during initial runs and after resetting to zero. It stabilizes after approximately 100m of running. During this initial learning phase it is sometimes necessary to readjust the fine offset (section 7.1).

The purpose of estimating angular misalignment and automatically compensating is to avoid the need for very accurate mechanical setting up.

As camera skew relates to a particular camera poise it is necessary to reset it to zero and allow it to estimate a new value each time a camera is moved either deliberately or by accident. Small lateral camera adjustments by sliding within the stroke of the supplied camera bracket should not however require a reset, as camera poise should not be significantly affected. A reset to zero is achieved by highlighting reset and pressing button SK4 labelled select.

There are as many cameras skews as there are cameras. However, resetting skew resets skews for all cameras as well as any camera offsets.

Caution

After resetting camera skew it will probably be necessary to reset the fine offset.

Camera skews that settle to values in excess of 4 degrees indicate poor camera alignment requiring improvement.

Camera Offset (only present with multiple cameras on the same section)

Camera offset is the lateral displacement error between two or more cameras fitted to the same section. Like skew it is estimated by Robocrop's computer programme during field operations. The rate of change of this estimated displacement is highest during initial runs and after resetting to zero. It stabilizes after approximately 200m of running. There are as many offsets as there are cameras on a section. The first camera is the master from which offsets are derived and so it always has zero offset.

The purpose of estimating lateral misalignment and automatically compensating is to avoid the need for very accurate mechanical setting up.

As camera offset and camera skew are related resetting either offset or skew resets both figures for all cameras fitted.

Error log

This is a log of a number of different automatically generated error messages (camera connections, micro-controller connections and excessive camera skew). Selecting “view log” displays single line messages that can be helpful with diagnostics. Not all messages indicate serious faults. On exit you have the option to select “clear” which erases the messages or close which returns to the advanced set up & diagnostics menu without erasing. These messages are saved between sessions.

Tip When seeking advice over the telephone it is very useful to have an exact word for word record of any error messages and to make a note of numeric error codes.

Steering test

This is a test function that checks a number of components and settings relating to side shift or steering angle movement. Included in the test are micro-controller communication with the main computer, direction of hydraulic flow, rate of flow (too fast or too slow), correct side shift/disc potentiometer connection polarity and continuity over the stroke. It also detects mechanical obstructions preventing full travel. This is achieved by exercising the hydraulic cylinder and recording the response. It is therefore necessary to turn the hydraulic supply on. For multi section machines you are prompted to select which section to test.

Caution

Ensure that the side shift/disc steering mechanism is clear of obstructions and people before operating the hydraulic test function.

Hydraulic flow test

This test runs all the configured rotors up to maximum speed (4 Rev/s) to ensure that sufficient oil flow is available. Tractor engine revs should be set to a normal operating speed. A graph plotting both oil supply pressure in green (if condition monitoring is fitted) and flow in red (calculated from actual rotor speed) against demanded rotor speed is displayed. If pressure drops significantly during this test a warning will be displayed indicating that tractor engine revs need to be increased or alternative higher capacity oil supply sought. If the pressure only drops close to maximum speed it may be possible to continue operation but with a reduced maximum speed.

Test Rotors

This is a test function relating to the control of the rotary cultivator units and provides a more rigorous test than that routinely conducted at start up. It is necessary to turn the hydraulic supply on (or electric supply for electric rotors) and you will be prompted to lift the implement and select “begin”. The screen will display a blank graph with actual rotor speed (revs/s) on the vertical axis and demanded rotor speed (revs/s) on the horizontal axis. The first rotor will start to rotate and as it does so two lines are plotted on the graph. The straight red line represents an ideal 1 to 1 relationship and the green line shows actual performance during the test. Due to hysteresis effects one should expect the rising green line to follow the red line displaced slightly to the right as the rotor accelerates and as it decelerates the falling green line should be displaced slightly to the left. The green line should be relatively smooth, though a small amount of ripple is acceptable. Sizable spikes in the green plot may be symptomatic of component faults. The test sequence lasts approximately 20 seconds per rotor. Users are prompted to select which rotor is to be tested. If “all” is selected the system tests each rotor in turn refreshing the graph on each occasion.

If the test was passed without problem the user is given the message “test passed”. If one or more rotors ran but with larger than expected average errors the user may be advised to recalibrate (see procedure below). Recalibration should only be necessary if components (motors, valves or microcontroller) have been changed. Please seek advice from your Garford dealer if recalibration is advised with any regularity. Electric rotors do not require calibration and so a “recalibration required” message would indicate a fault.

If an error is detected a diagnostic message is displayed. “Rotor too slow” would suggest that insufficient oil was available. “No rotation” would indicate that the hydraulic supply might not be switched on (electric supply for electric rotors) or connections have not been made. “Reverse rotation (rotor no)” suggests that the hydraulic pipes to the identified units are fitted the wrong way round. Electric rotors should not produce the “reverse rotation” message as that would indicate a wiring error. “Coms fail” indicates a communication error between the main computer and the micro controller. To return to the advanced set up and diagnostics screen press “done” and if necessary repeat the test once the cause of any fault has been addressed.

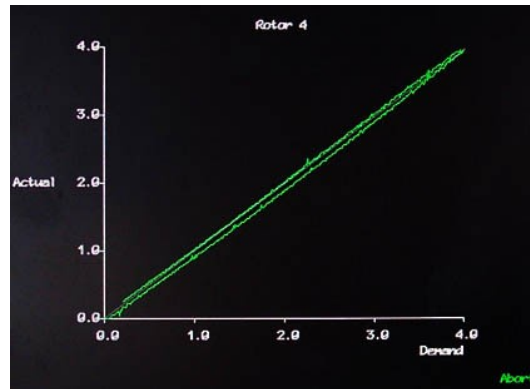

Typical graphical representation of a successful rotor test

Calibrate Rotors (hydraulic rotors only)

This option goes through a similar process to the rotor test except that rotor speed (revs/s) is displayed on the vertical axis and demanded solenoid current (amps) on the horizontal axis. The red line represents the systems stored calibration for that particular unit and the green line shows actual performance during the test. Due to hysteresis effects one should expect the rising green line to follow the red line displaced slightly to the right as the rotor accelerates and as it decelerates the falling green line should be displaced slightly to the left. The green line should be relatively smooth, though a small amount of ripple is acceptable. Sizable spikes in the green plot may be symptomatic of component faults. A green line smoothly ramping up and down that does not follow the red calibration plot suggests that the unit needs recalibrating.

If the calibration process was successful the message “Calibrated OK” is displayed and the user is given the option to save the calibration, discard it, or use defaults. Once one of these options is selected the user is returned to the advanced set up and diagnostics screen.

Problems detected during calibration produce similar diagnostic messages to the test process. It is sometimes possible to refine a diagnosis by inspection of the calibration plot. For example:

- A spikey trace that roughly follows the calibration line might indicate a faulty encoder or incorrectly tensioned encoder belt (pre 2013 machines).
- A trace that simply followed the zero line on the horizontal axis would indicate that the encoder is not working at all or has become disconnected.
- A trace that produced a rectangular series of spikes to a limited number of values would indicate that one of the encoder signal lines has become disconnected.
- An apparently normal trace with very short breaks once every full rotation would indicate that the index sensor is not working
- A trace that starts by running along the zero line further than normal (>1 amp) and then jumps steeply up to follow the red line might indicate a sticking valve or possibly a motor that is leaking internally. Oil temperatures above 70° will cause valves to stick.

If diagnosis is proving difficult it is possible to photograph the screen and e-mail it to Garfords for expert interpretation. To return to the advanced set up and diagnostics screen press “done”.

Examples of calibration traces

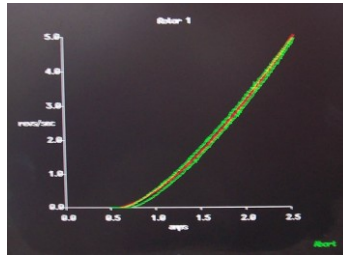

Typical graphical representation of a successful calibration

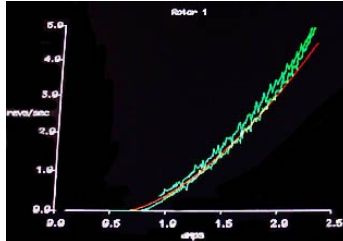

A jerky plot may indicate either an incorrectly tensioned encoder drive belt or a faulty encoder

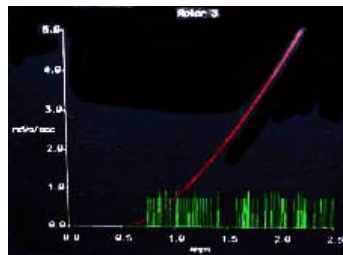

A trace that produced a rectangular series of spikes to a limited number of values would indicate that one of the encoder signal lines has become disconnected

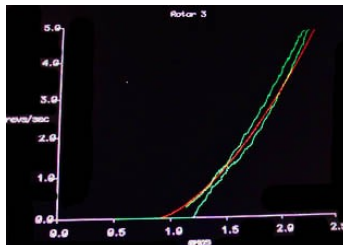

>1amp to start rotation could indicate a sticking valve or a motor that is leaking internally

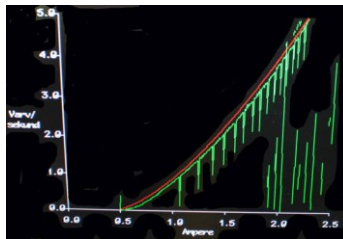

Discontinuity once per revolution could indicate an index sensor fault

Test nozzles (only shown if nozzles are in active configuration file)

Tests nozzles for leaks and facilitates a visual check of spray pattern.

Flush nozzles (only shown if nozzles are in active configuration file)

Turns on half (alternate) nozzles for 1 second then turns on the other half in a continuous cycle.

Units

Selecting toggles between metric and imperial units. This change affects all user screens and the configuration file editor.

To exit the advanced set up and diagnostics menu screen press Sk6 labelled "done".

7.4 Configuration file editor

Configuration files store information relating to a specific crop planting pattern and implement/tractor geometry that is necessary for plant tracking. Each combination of a different crop pattern or implement geometry requires its own configuration file.

The configuration file editor allows experienced users to create and edit configuration files, but also provides a method of changing general machine settings such as language and units. It is reached from the advanced set up and diagnostics menu by pressing button Sk1 labelled “config editor”.

Less experienced users are advised to contact their Garford dealer who can supply them with customised configuration files.

The editor is available in English language only.

This editor requires a standard PC keyboard to be connected to a PS2 or USB socket on the base of the console. Console buttons are not used.

Overview of screen display and how to edit files

Navigation through the editor is via keyboard arrow keys with the enter key used to select a highlighted option.

Tip Context sensitive help is available by pressing the ? key with the cursor on the relevant title.

The first line provides options to save and exit, create a new configuration file based on defaults (“New”) or an existing file (“Copy”), toggle between metric and imperial units (also possible from advanced set up and diagnostics menu), and select between standard and advanced versions of the editor. In the vast majority of cases the options available on the standard editor are all that is required. The advanced version offers the same features with some additional settings that would normally be factory set. Do not use the advanced editor without consulting Garfords. There is also an option to select alternative languages. Once selected the user is presented with a number of national flags depicting available languages. Highlighting and selecting a flag will change the language used in all configurations and in all user screens except for the configuration file editor.

The second line lists the configuration files already stored on the machine. Pressing the horizontal arrow key scrolls the cursor to reach file names lists that may extend off the edge of the screen.

The settings and their values displayed on the remainder of the screen relate to the file selected on the second line, or give default values if a new file has been selected. To edit a selected file press the enter key. The cursor will jump to the first setting option which can be edited using the keyboard in the normal way. Pressing Esc will return the cursor to the headings. When you have finished creating or editing a file select “Save & Exit” and press enter.

Note: When you next run Robocrop you need to select the appropriate configuration file.

```

Configuration Editor for hoe-5.4.5
Save&Exit  New      Copy      Units      Advanced  Language
Brassica   ▶ Lettuce ◀   New1

General
Name                          Lettuce
Width (m)                      2.0
Rotor disc size (m)            0.18
Nominal plant spacing in row (m) 0.28
Sections
Edit section 0 ->
Cameras
Edit camera 0 ->
Edit camera 1 ->
Microcontrollers
Edit µC 0 ->

↑ ↓ → ← to navigate, 'Enter' to select, ? for help.

```

Configuration file editor screen with standard settings selected

Settings available from the standard editor

General settings

The first setting provides an opportunity to change the configuration file name. Implement width is the second standard editor implement setting. The third, rotor disc size, is a parameter relating to disc design that is available from Garfords. It is usually less than the average plant spacing. The final setting is the average within-row plant spacing which is best determined by measuring a sample in the field. In doing this calculation it is best to ignore very large gaps due to missing plants and where the spacing is variable it is better to use a figure closer to the shortest spacing.

The remaining categories of settings relate to machine sub components. In all cases it is possible to have more than one of these sub components on a single machine. For example a machine may have two cameras so there will be the option to edit the settings for each of these cameras independently. Microcontroller number refers to master microcontrollers of which there may be more than one for multi-section machines. For reasons relating to internal computing conventions the numbering of these sub components always starts at zero, e.g. the first camera is numbered 0 and the second 1.

To edit the settings for any of these subcomponents move the cursor down to the item you wish to edit and press return. This will get you into the edit page for that particular component. Once you have completed editing that sub component you can return to the configuration editor main screen by running to the bottom of the list of items using the down arrow or return keys. Alternatively pressing the escape key will bring you back up from any position.

Section settings

A section is defined as a frame that has independent steering. Most implements will have only one section. However, it is possible to have an implement with up to three independently steered sections. This is useful when it is required to span multiple drill/transplanter bouts.

In the example below there is only one section. The settings are the maximum angular deflection and the effective arm length of the steering disc mechanism respectively. "Pot scale" refers to calibration of the rotary potentiometer that measures steer angle. The final setting allocates which cameras are fitted to that section. It is also possible to have settings (if appropriate defaults are installed) for side shifted machines (not shown in example below).

```

Configuration Editor for hoe-5.4.5
Save&Exit  New      Copy      Units      Advanced      Language
Brassica   Lettuce   New1

Section 0 (steered) :
Peak steer angle (°)      8.021400
Steering arm length (m)   0.338
Pot scale (°/bit)        0.024414
Cameras mounted          0, 1

↑ ↓ → ← to navigate, 'Enter' to select, '?' for help.

```

Configuration file "Section" standard editor screen

Camera settings

The first three settings relate to camera mounting geometry as illustrated below. Camera height is the vertical distance in m (or inches with imperial units set) from ground level to the camera lens when the implement is at its normal working height. Look ahead is the horizontal distance from a point directly below the centre of the camera lens the centre of the image in the ground plane (depicted by cross hairs in "manual" mode). Distance ahead of the rotors is the horizontal distance in m (or inches with imperial units set) from a point vertically below the camera lens back to the cultivator blades. NB If the camera is behind the rotors then this number should be entered as a negative value.

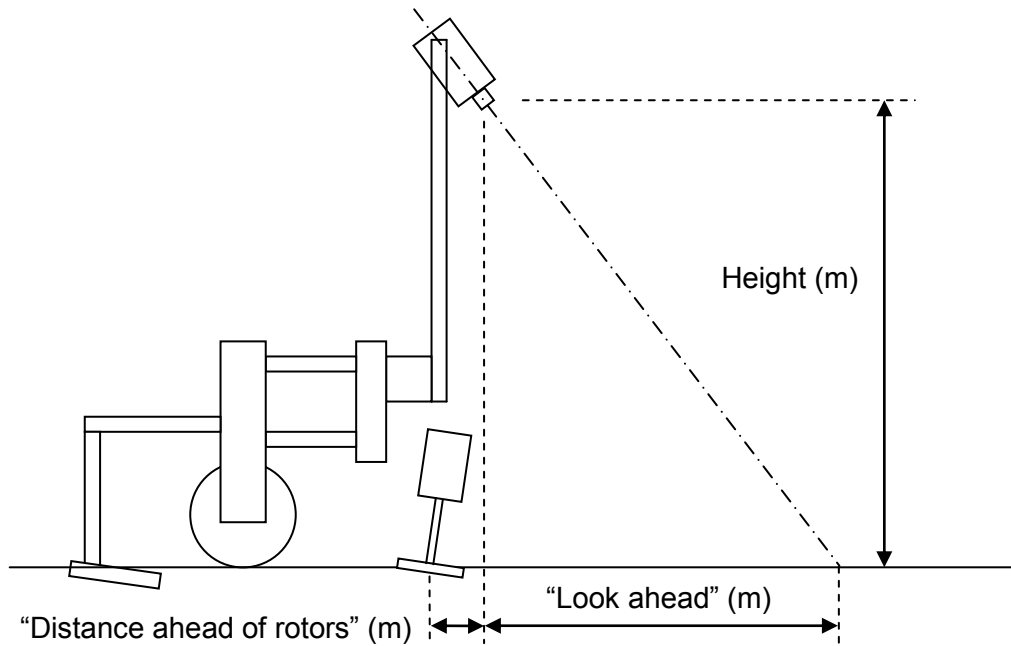

The next settings relate to what is seen in the image, number of rows and spacing between them. The number of rows entered here determines how many rows are used for template construction.

The spacing between rows is normally uniform across the field of view and is therefore a single figure. However, some crop geometries with a number of different row spacings in the same scene require a more complex arrangement. The syntax for this is based on the assumption that the pattern is symmetrical about the centre line and starts with the central row spacing working out to the edge. Figures are comma delimited. In the case of an even number of rows the first figure is always the whole row spacing, not the distance from the centre line to the next row. The following examples cover likely configurations.

Odd no of rows irregular spacing example

Rows 5
Spacing 0.4,0.5

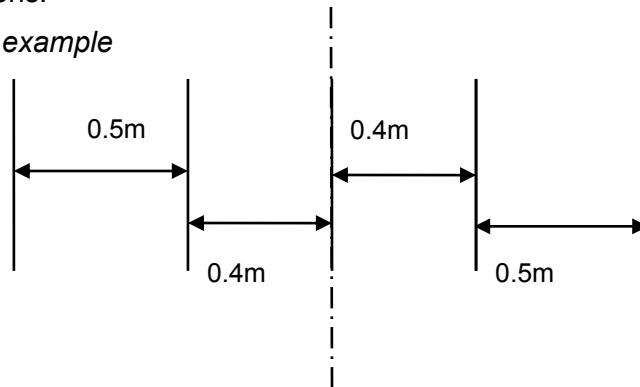

Even no of rows regular spacing example

Rows 4
Spacing 0.4

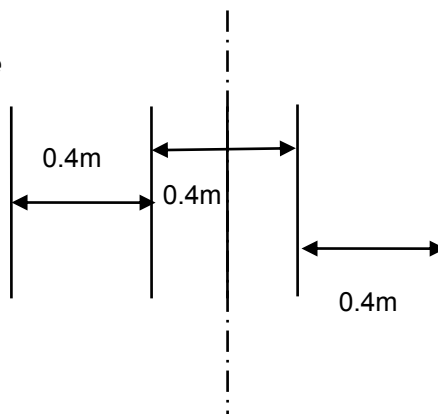

In the special case of only following only one row the most accurate tracking will be achieved with the row spacing set to between two and three times the width of the crop foliage with an absolute minimum of 20cm.

```

Configuration Editor for hoe-5.4.5
Save&Exit      New      Copy      Units      Advanced      Language
Brassica       Lettuce   New1

Camera 0:
Height (m)                1.5
Look ahead (m)            0.530005
Distance ahead of rotors/nozzles (m) 0.0
Rows                      5
Row spacing (m)           0.3

↑ ↓ → ← to navigate, 'Enter' to select, '?' for help.

```

Configuration file "Camera" standard editor screen

Microcontroller settings

This page allows the user to select which crop rows are allocated to rotor or nozzle control channels associated with that master microcontroller. For electric rotors rows are allocated to channels in ascending numeric order (defined by CAN address). Hydraulic rotors are connected to microcontrollers via hydraulic control boards that have six channels each. Rotors connected to hydraulic board are also allocated channels in ascending numeric order. However, the first channel of a second hydraulic rotor board would be allocated channel 7 irrespective of how many channels were used on the first board. Unused channels are allocated row "0" which is a code that will cause those channels not to be used. For example, an eight row machine with one master microcontroller that has half its rotors wired to one hydraulic control board, and the other half to a second, would have the row allocation 1,2,3,4,0,0,5,6,7,8

The unused rotor row "0" allocation is also used when a rotor is not required for a particular crop. For example, a single camera, single microcontroller board machine is equipped with five rotors for five rows. Under normal circumstances cultivating all five rows the row number allocation would be: 1, 2, 3, 4, 5. If however the same machine was to be used on a four row crop using the outer two rotors on each side then the allocation would be: 1,2, 0, 3, 4.

In some special cases it may be beneficial to allocate more than one rotor to a row. For example a three row machine that maximises cultivated area by fitting 2 rotors arranged either side each row would have the rotor row allocation 1,1,2,2,3,3

Nozzle control boards are treated in exactly the same way as hydraulic rotor boards except that these boards have 12 channels.

Note that row numbers unlike camera, section and microcontroller numbers start from number 1.

```

Configuration Editor for hoe-5.4.5
Save&Exit      New      Copy      Units      Advanced      Language
Brassica       Lettuce   New1

Microcontroller 0:
Rotor row numbers          1, 2, 3, 4, 5, 6, 7, 8, 9, 10
Nozzle row numbers        1, 2, 3, 4, 5, 6, 7, 8, 9, 10

↑ ↓ → ← to navigate, 'Enter' to select, '?' for help.

```

Configuration file "Microcontroller" standard editor screen

Additional settings available from the advanced editor

Under normal circumstances it should not be necessary to alter any of the additional parameters listed in the advanced editor. Please consult Garfords before making any changes.

Additional general settings

The advanced version allows the user to enter the number of cameras and microcontrollers fitted.

Odometer scale relates to the distance travelled between counts from the encoder fitted to the odometer wheel. It is calculated from the pulses per revolution (PPR = 4096) of the encoder and the diameter of the ground engaging wheel according to the formula: $\pi \times \text{Wheel diameter} / \text{PPR}$.

```

Configuration Editor for hoe-5.4.5
Save&Exit  New      Copy      Units      Advanced  Language
Brassica   ▶ Lettuce ◀  New1

General
Name                Lettuce
Width (m)           2.0
Rotor disc size (m) 0.18
Minimum plant spacing in row (m) 0.14
Nominal plant spacing in row (m) 0.28
# of cameras        2
# of µCs            1
Odometer scale (m/bit) 3.8200e-04
Sections
Edit section 0 ->
Cameras
Edit camera 0 ->
Edit camera 1 ->
Microcontrollers
Edit µC 0 ->
Options
Change optional features ->

↑ ↓ → ← to navigate, 'Enter' to select, '?' for help.

```

Configuration file editor screen with advanced settings selected

Additional section settings

For disc steered machines this version of the screen allows the user to alter parameters relating to the slide linear potentiometer used for the working screen light bar as well as the rotary steering potentiometer. The value defined as central (normally 2048) can also be altered for both potentiometers.

The damping term relates to disc steering.

It is also possible to define which master microcontroller is used to control section steering and from which microcontroller that section should take its lift status and odometric speed. Where multiple channels are available on the microcontroller it is assumed that channel 0 is used. If the second channel is used the syntax would be 0/1 to indicate the second channel of the first microcontroller. Where two channels are both used (as illustrated below by the twin odometers) the syntax may be entered as 0/0, 0/1, or 0, 0/1.

```

Configuration Editor for hoe-5.4.5
Save&Exit  New      Copy      Units      Advanced  Language
Brassica   Lettuce  New1

Section 0 (steered) :
Peak steer angle (°) 8.021409
Steering arm length (m) 0.338
Pot scale (°/bit)    0.024414
Pot centre           2048
Lightbar peak travel (m) 0.14
Lightbar pot scale (m/bit) 7.3240e-05
Lightbar pot centre  2048
Damping (s)         0.625
Steer using µC       0
Lift on µC           0
Odometer on µC       0, 0/1
Cameras mounted      0, 1

↑ ↓ → ← to navigate, 'Enter' to select, '?' for help.

```

Configuration file "Section" advanced editor screen for a disc steered machine

```

Configuration Editor for hoe-5.4.5
Save&Exit  New      Copy      Units      Advanced  Language
Brassica   Lettuce   New1

Section 0 (Front mounted side shift) :
Peak travel (m)          0.075
Pot scale (m/bit)       1.6280e-04
Pot centre              2048
Lightbar peak travel (m) 0.15
Lightbar pot scale (m/bit) 1.6280e-04
Lightbar pot centre     2048
Distance ahead tractor rear axle (m) 3.0
Steer using µC          0
Lift on µC              0
Odometer on µC          0/2
Cameras mounted        0, 1

↑ ↓ → ← to navigate, 'Enter' to select, '?' for help.

```

Configuration file "Section" advanced editor screen for a side shift machine

Additional camera settings

Additional camera parameters are the lens focal length and a figure relating to correcting for camera lens distortion. It is also possible to change the camera bus index though this should not be changed from the camera number in blue above without taking very expert advice.

```

Configuration Editor for hoe-5.4.5
Save&Exit  New      Copy      Units      Advanced  Language
Brassica   Lettuce   New1

Camera 0:
Camera bus index        0
Height (m)             1.5
Look ahead (m)         0.530605
Distance ahead of rotors/nozzles (m) 0.0
Rows                   5
Row spacing (m)        0.3
Focal length (m)       0.0155
Distortion              3.1900e-06

↑ ↓ → ← to navigate, 'Enter' to select, '?' for help.

```

Configuration file "Camera" advanced editor screen

Additional microcontroller settings

In some circumstances, e.g. where more than one rotor cultivates a single row it is useful to define a forward offset for that particular device.

```

Configuration Editor for hoe-5.4.5
Save&Exit  New      Copy      Units      Advanced  Language
Brassica   Lettuce   New1

Microcontroller 0:
Rotor row numbers     1, 2, 3, 4, 5, 6, 7, 8, 9, 10
Rotor forward offset (m)
Nozzle row numbers    1, 2, 3, 4, 5, 6, 7, 8, 9, 10
Nozzle forward offset (m)

↑ ↓ → ← to navigate, 'Enter' to select, '?' for help.

```

Configuration file "Microcontroller" advanced editor screen

Optional Features

These allow the user to be given extra facilities. The first provides an additional line on the set up screen labelled "Clearance" which gives the option for the in-row rotors to cultivate slightly (typically 5mm) tighter to the crop plant, leave a normal clearance, or provide a slightly larger gap than normal. Changing clearance in this way is best achieved by physically changing discs, but the software change is more convenient for small areas.

The third provides an option to work on red crops by inverting the colour selection or using an IR filter in the camera. The fourth allows that choice to be made per camera.

The fifth and sixth relate to customising the fine offset which can be useful if extra stroke is required working across steep slopes for example. One allows the maximum number of fine offset steps to be changed (default is 6) and the other allows the size of those steps (default 10mm) to be modified.



Configuration file "Optional Features" advanced editor screen

Tip Context sensitive help is available within the configuration editor by pressing the ? key with the cursor on the relevant title.

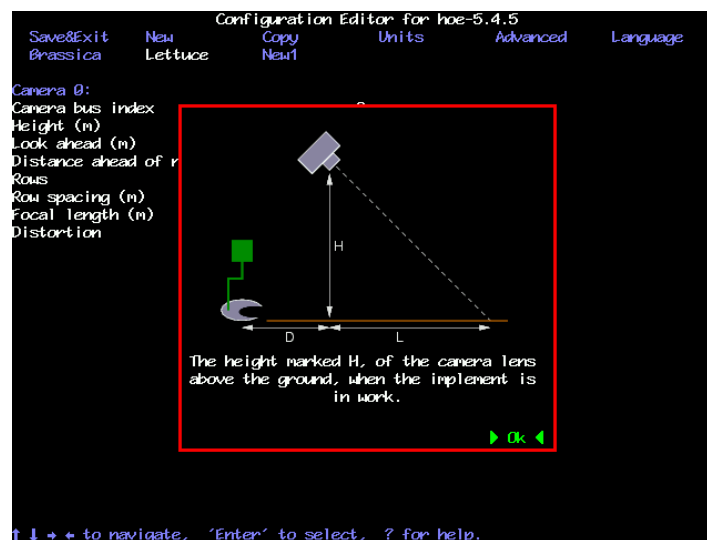

Example of context sensitive help obtained by using the ? key

8. Maintenance and Storage

Please follow the maintenance and storage instructions below in order to ensure your Robocrop precision guided implement stays in first class working order

1. There are no lubrication points on the side shift.
2. Check that dirt does not build up on the side shift rails and rollers and clean if necessary. However, take care not to pressure wash electrical components such as the potentiometer, camera, solenoid valves, or control box. It is also inadvisable to pressure wash the rotor units as they are not completely sealed and do contain moisture sensitive components.
3. Regularly check the routing of hoses and cables and protect against chaffing.
4. Check that the implement hydraulic filter indicator does not show that the filter is clogged. Clogged filters should be replaced before working. Repeated clogging should be investigated as it indicates high levels of contamination that may cause expensive components to be irreparably damaged. In any case filters should be replaced as part of an annual service.
5. Always store the hoe fully undercover. Although the camera, loom and computer box are shower proof damage may result if they are exposed to wet weather for extended periods.
6. The console and camera should always be stored in a dry atmosphere.
7. Always ensure the correct 20 amp fuse is fitted in the power supply.
8. Always ensure the correct supply polarity is adhered to.
Blue = negative, Brown/Orange/Black + (fused side) = positive.
9. Always ensure the correct oil flow direction is followed Red=supply, Blue=return.

9. USB Update and backup procedure (service menu)

If the console is switched on with a USB memory stick inserted into the socket under the inspection hatch the following service options are listed and can be selected using console keys:

- Backup configuration data to USB
- Restore configuration data from USB
- Capture images to USB
- Apply update

The first backs up configuration files and system data onto a USB memory stick within a file called hoe-backup.tgz. This file can be e-mailed to Garfords to aid remote diagnosis.

It is also possible to do the inverse operation restoring from a file of the same name.

The image capture utility allows users to take still images from any cameras connected to the machine and load them onto the USB memory stick. These can be e-mailed back to Garfords for evaluation of issues relating to the camera or crop scene.

The update option lists any update files found on the memory stick and the user can select which to apply. This is the normal process for updating machine software.

It is possible to reach a more extensive service menu by connecting a keyboard and holding the alt key on power up.

10. Trouble shooting

Problems have been divided into six categories listed below. Select the most appropriate category and work through the flow chart. Please consult your Garford dealer for any other problems.

1. Console fails to start up correctly
2. Console shows a working screen but the side shift/steered discs do not respond correctly
3. All systems appear to be functioning and the steering test passes but lateral positioning performance is poor
4. Lateral positioning is good but rotors are not rotating correctly around crop plants
5. Lateral positioning is good and all rotors pass the rotor test but rotors are not rotating correctly around crop plants
6. Lateral positioning is good, all rotors pass the rotor test and are rotating about crop plants but their motion is jerky

1. Console fails to start up correctly

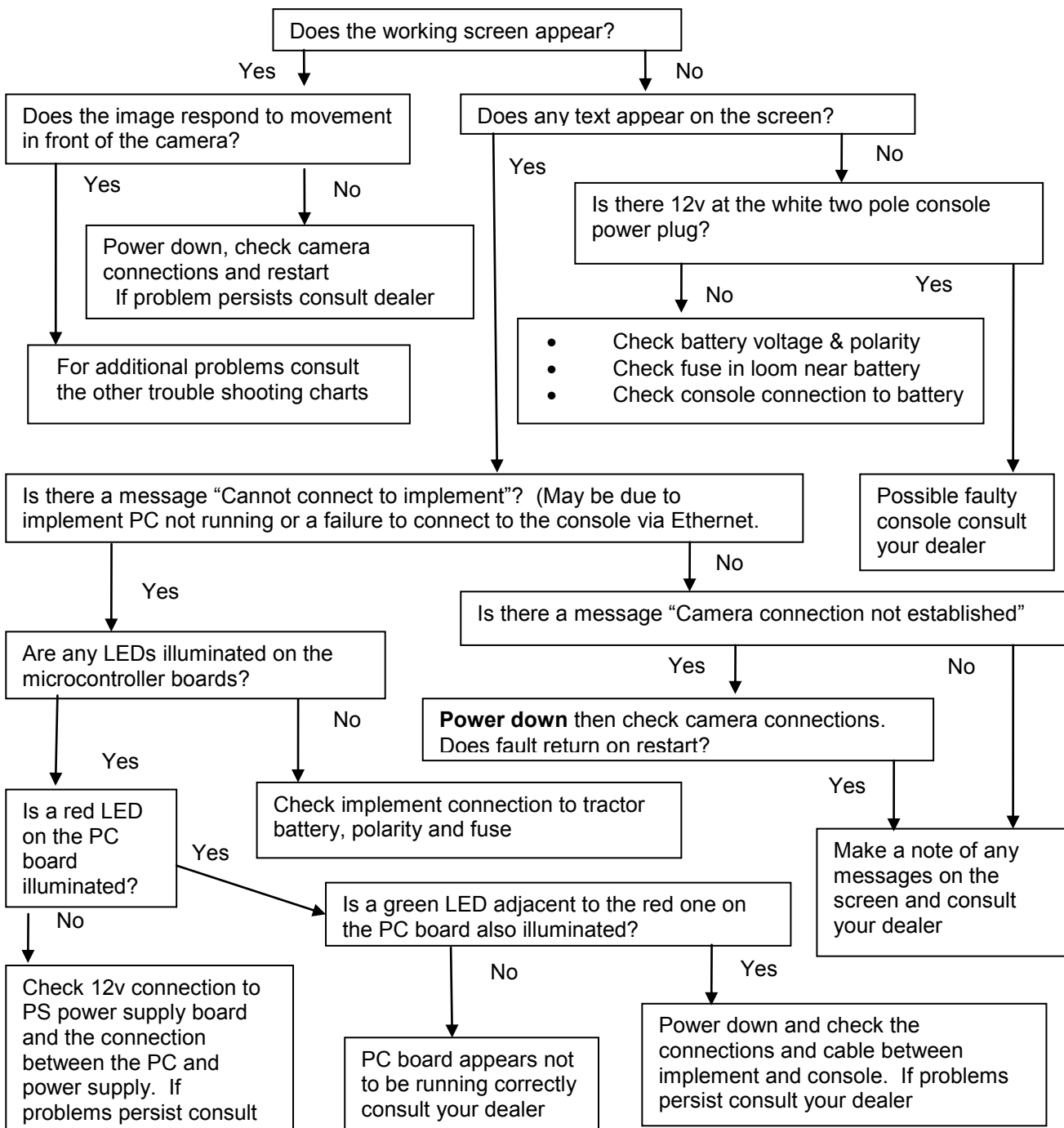

2. Console shows a working screen but the side shift/steered discs do not respond correctly

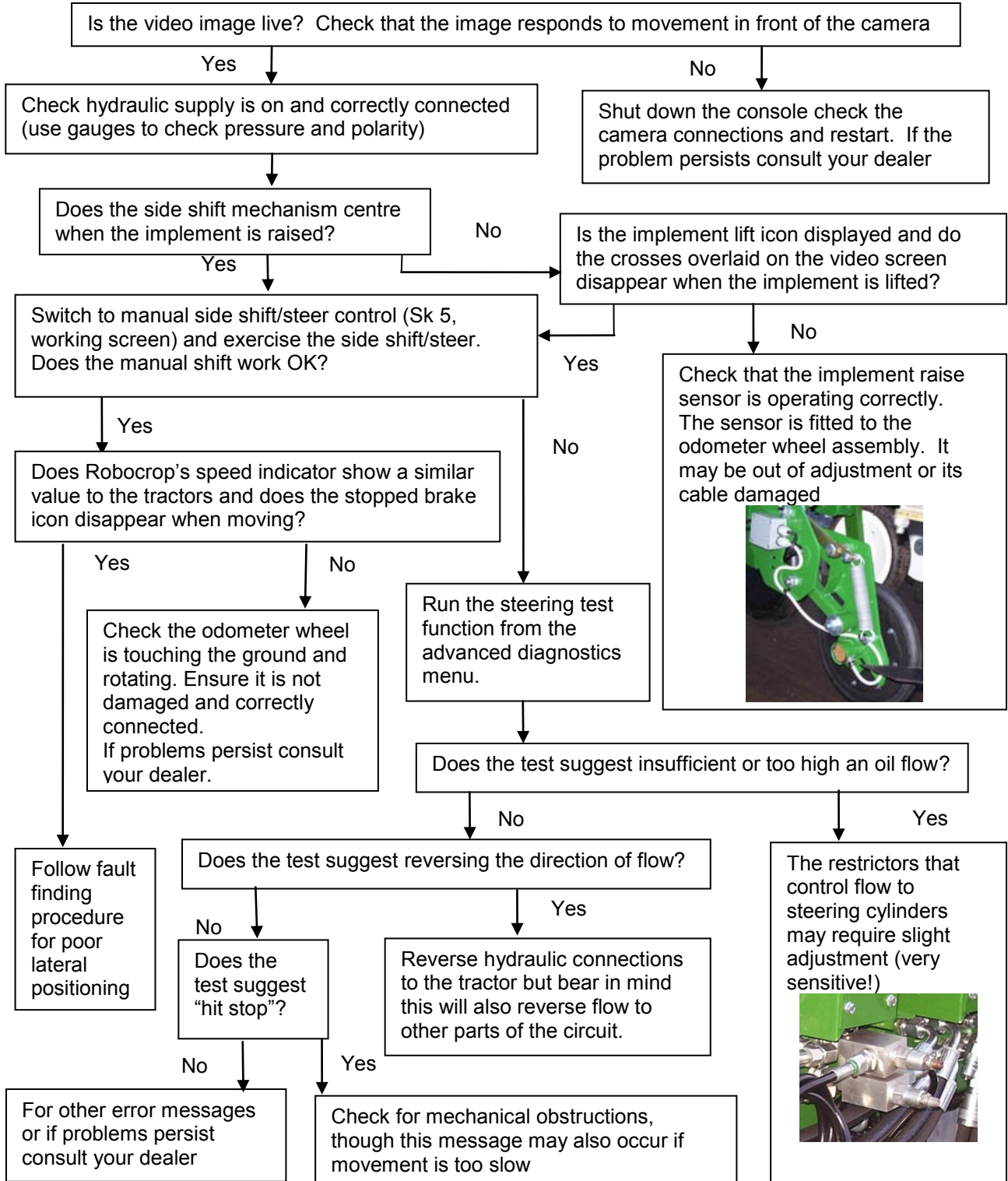

3. All systems appear to be functioning and the steering test passes but lateral positioning performance is poor

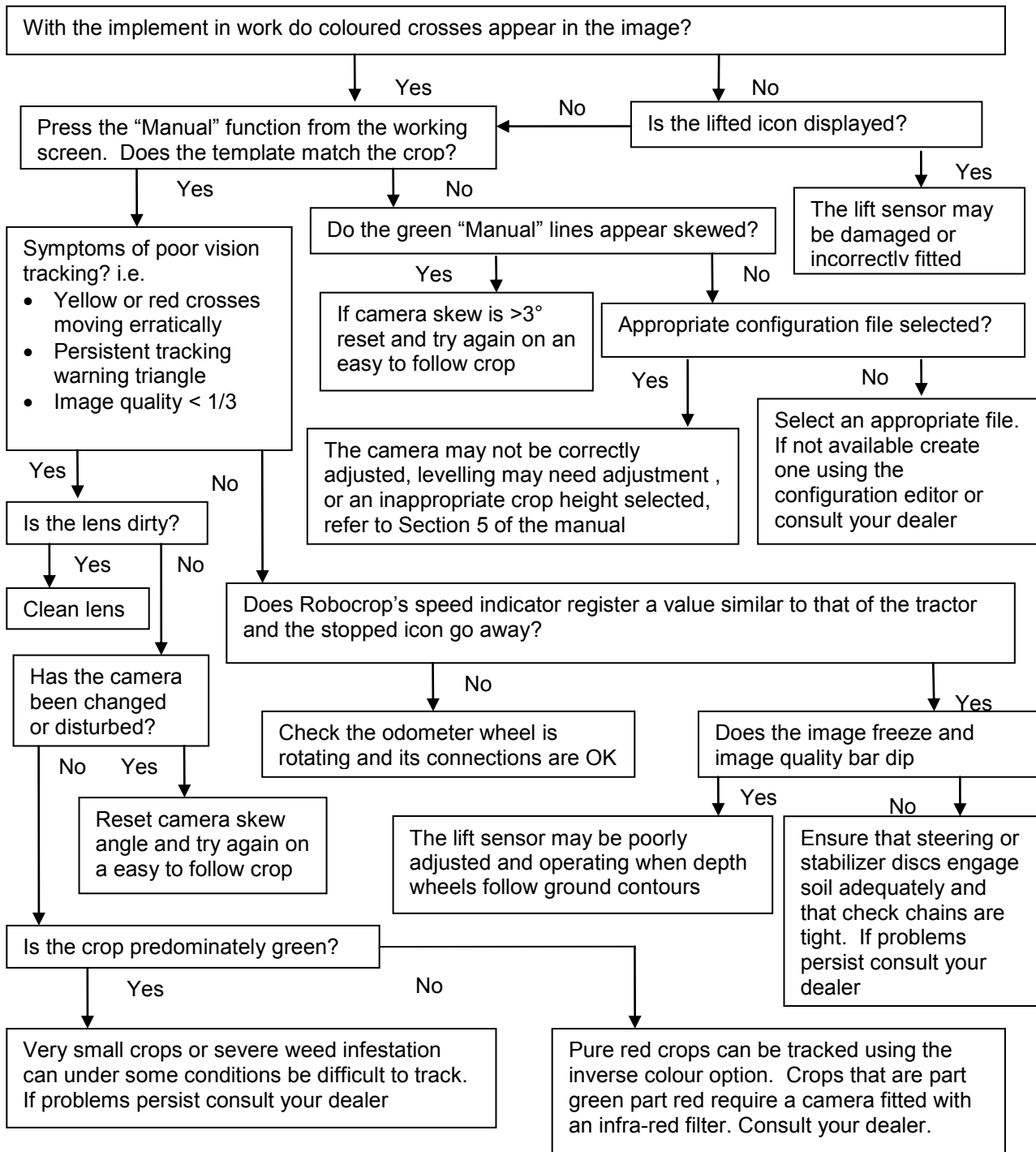

4. Lateral positioning is good but rotors are not rotating correctly around crop plants

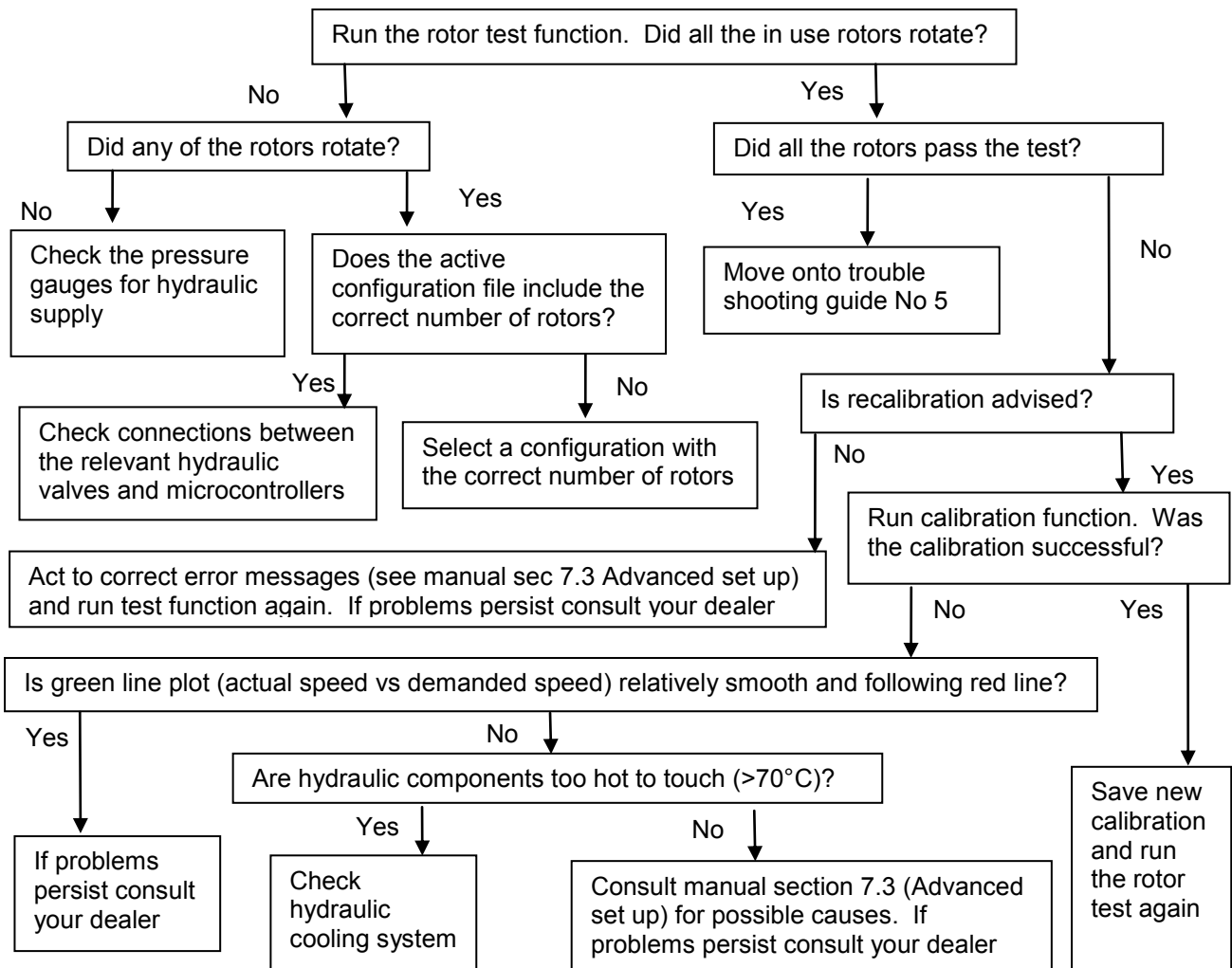

5. Lateral positioning is good and all rotors pass the rotor test but rotors are not rotating correctly around crop plants

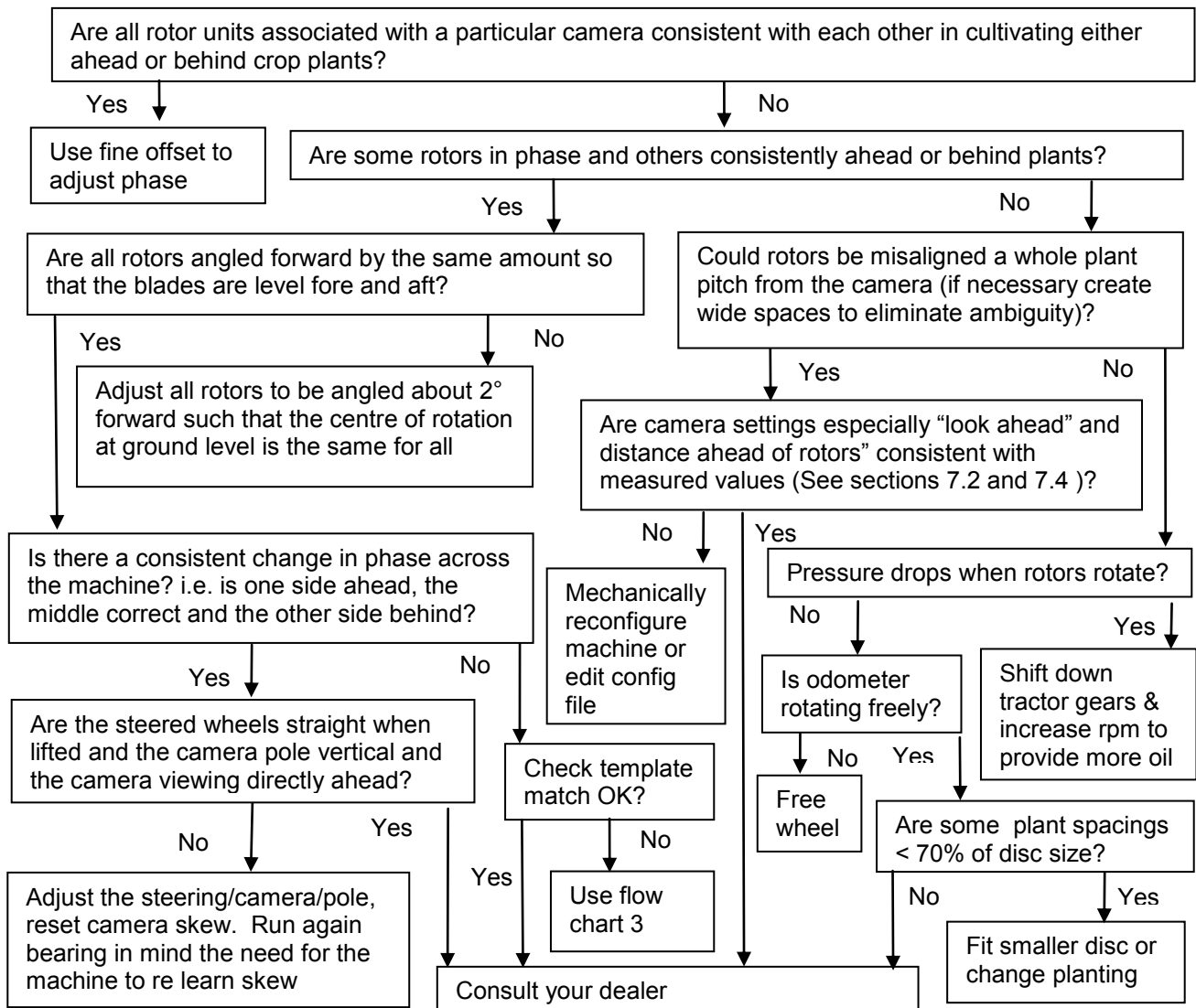

6. Lateral positioning is good, all rotors pass the rotor test and are rotating about crop plants but their motion is jerky

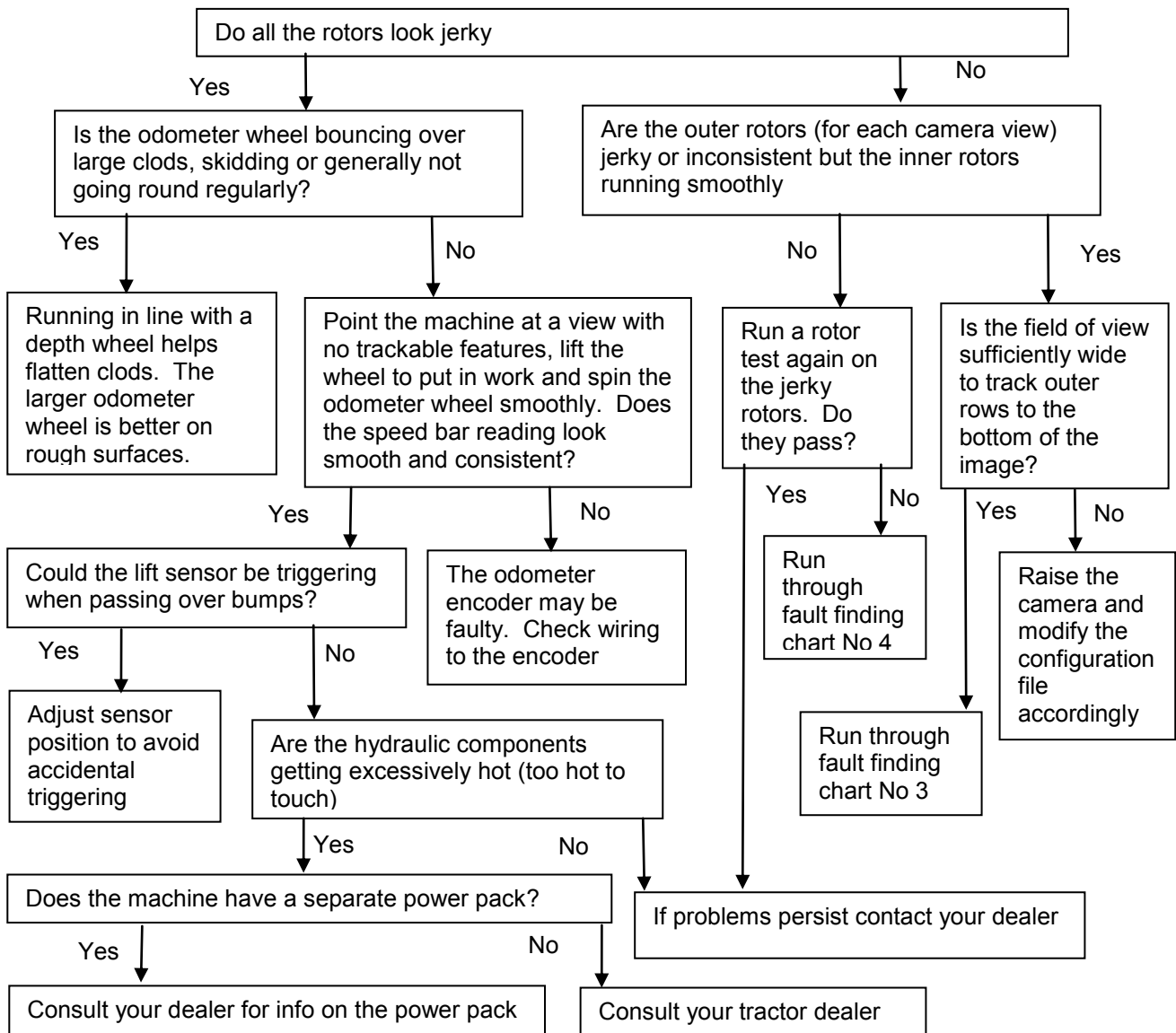

Annex 1 – Optional inter-row operation (Software version 6.1.2)

Introduction

It is possible to use your Robocrop In-row weeder without rotor blades to perform inter-row cultivation. Robocrop inter-row guidance has been written in a way that is compatible with in-row machines and their configuration files. This allows users to switch to inter-row cultivation by selecting the appropriate programme at start up and requires no mechanical changes other than the removal of rotor blades.

Robocrops inter-row guidance software follows crop rows rather than individual plants and is therefore well suited to cultivation at advanced growth stages when individual plants may not be discernible within the row. However, this well proven software is also effective at early stages of crop growth.

Set-up

Machines loaded with both in-row and inter-row software will give you the option shortly after powering up to select which mode you wish to work in. If you do not make a selection within 10 seconds the machine will automatically start running in the mode used last.

You can select the appropriate configuration file from the set up screen in the usual way; though parameters relating to spacing in-the-row and disc size etc. will have no bearing on performance. The working screen is very similar to the in-row version except that the fine offset is only available laterally and controlled by soft keys labelled with left and right facing arrows. Similarly the tracking warning triangular symbol, should it occur, indicates a lateral tracking warning only.

To minimise the risk of crop damage it is advisable to remove the rotor discs, though when operating in inter-row mode the motors should not turn.

Working in the field

Camera skew figures learned during initial running are shared by inter and in-row software versions. It is not therefore necessary to go through any special procedure if the machine had previously been run in in-row mode. However, we would advise caution with initial runs in any case. If the machine has not been run as an in-row weeder previously, or the camera skew has been reset, it will be necessary to proceed with caution on an easy to follow crop whilst camera skew is learnt (see section 5, step 3 of the in-row weeder manual).

On placing the machine down into work two sets of markings will be superimposed over the live video image at the centre of the screen. The first are green lines representing the template to which crop rows are matched. The second are a series of eight crosses arranged from the top to the bottom of the image. These represent how well the template lines up at different levels up the image. Blue crosses in a relatively straight line indicate a good match. Yellow and red crosses that are not well aligned indicate a poor match that will give poor row following. If the match is not good follow the instructions in section 5 of the in-row manual.

In the absence of a maximum rotor speed the speed limit for inter-row cultivation is substantially increased and is normally limited by cultivation effects. We would normally advise against working at speeds greater than 12kph.

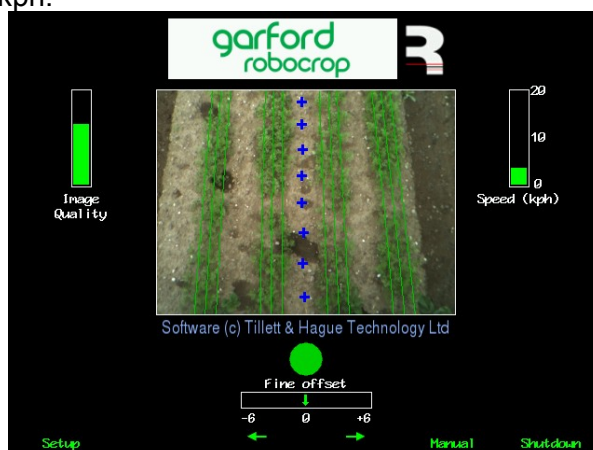

A typical working screen in inter-row mode for a single camera machine

Annex 2 – Thinning (Software version 7.0.3)

Introduction

Thinning uses a separate computer program written to control either chemical or mechanical thinning machines, however this annex only covers the option to mechanically thin when loaded onto an In-row weeder fitted with rotor units.

The system is designed to work with crops that are drilled at a relatively high population so as to ensure an adequate plant stand when germination might be poor. Once the crop has germinated the machine identifies individual seedlings and calculates which of those should be retained to achieve the desired uniform plant stand. The rotor units are then controlled in such a way as to retain those plants whilst removing the rest. The hardware requirements are exactly the same as in-row weeding, though special thinning discs are used to ensure very close cultivation.

The machine vision techniques that are used to identify individual plants are similar to, but not the same as those used for in-row weeding. However, like in-row weeding it is necessary to be able to identify individual plants. It is therefore important to conduct the thinning operation prior to plants touching along the row. In practice to achieve a reasonable treatment window between plants being first detectable (typically two true leaves) and plants touching along the row it is necessary to drill the crop at a spacing of no less than 75mm (3"). In general the wider the original drilled spacing the longer the treatment window and the better the performance.

As seedlings are small with an immature root structure they are generally more vulnerable to damage by soil movement than transplants. Experience has shown that mechanical thinning works best in relatively fine seedbeds and in soils that do not cap. A capped soil tends to break up and move in plates making it difficult to cultivate one plant whilst retaining a close neighbour. If necessary and where possible it is helpful to soften a capped soil with light irrigation prior to thinning.

Machine set up and operation is virtually identical to in-row weeding and so the following sections highlight only the differences.

Working screen

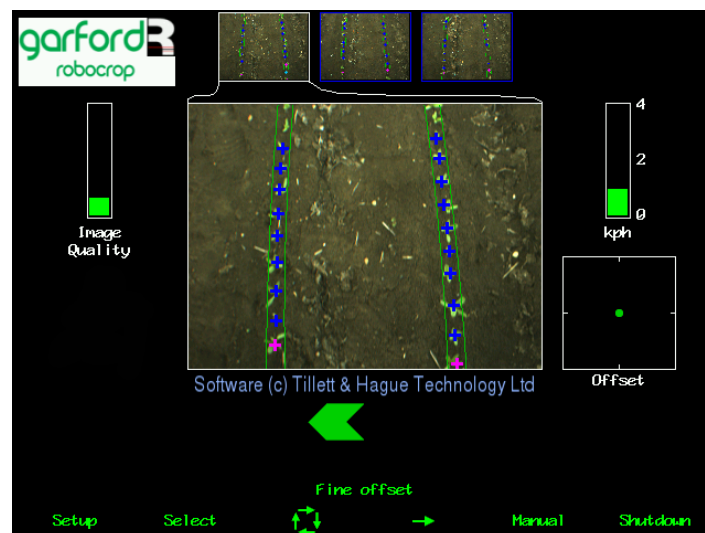

In addition to the blue and green crosses placed over individual plants the thinning software also overlays two green lines either side of a row. The width of these lines is defined by the “crop width” parameter (see below) and denotes the area in which the software is looking for plants. Crop width should be selected so that the crop plants lie just between the lines without significant overhang.

Plants that have been identified for retention are marked by the green cross turning purple as they reach the bottom of the image. The rotors are synchronised with plants marked with purple crosses.

Setup

Setup involves selecting configuration files in the normal way. Files contain normal in-row weeding parameters with an additional line at the bottom of the setup screen listing the spacing at which seeds were drilled and the target spacing which is required at the end of the thinning process.



Note: The crop size parameter relates to width in thinning mode as opposed to height for in-row weeding. It is assumed that all thinned crops are in the small height category.

The advanced settings and diagnostics screen is identical to the in-row weeding equivalent except for the software version number.

Configuration editor



The editor is identical to the in-row weeding equivalent except that the general settings have additional parameters for minimum plant spacing and drill spacing. The drill spacing should reflect the average plant spacing pre thinning ignoring gaps due to missing plants. Minimum spacing should be the smallest gap between plants that the user is prepared to accept. In this context nominal plant spacing is the target plant spacing post thinning.

Note: Given the integer nature of thinning it is worth considering how these figures will work together. For example if the drill spacing is 100mm and the nominal spacing is 300mm setting the minimum spacing to more than 200mm will in many cases preclude a smaller than nominal spacing forcing the machine create a larger gap that will in turn increase the average spacing overall.

All other configuration file screens are the same as their in-row equivalents.

Garford Farm Machinery
Frognall, Deeping St James,
Peterborough. PE6 8RR England
Tel. 01778 342642. Fax. 01778 348949
Email – info@garford.com