

AS1022.1

TWIN ROTOR MOUNT ASSEMBLY

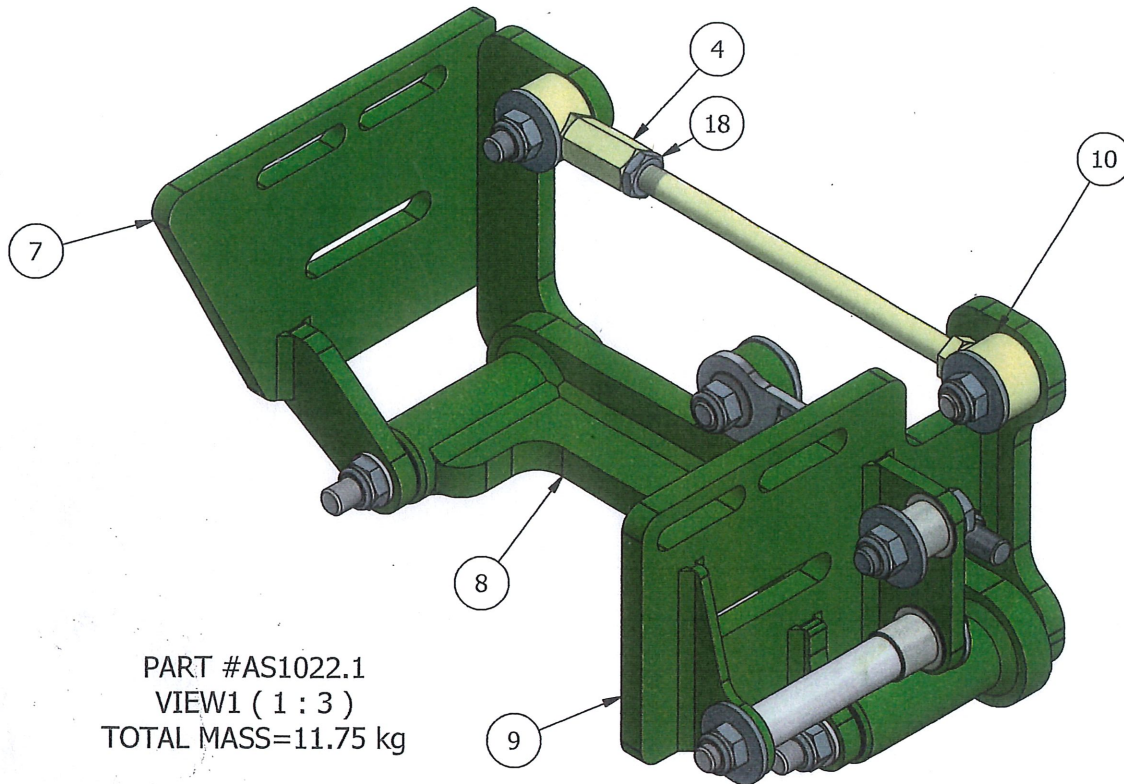

PART #AS1022.1
VIEW1 (1 : 3)
TOTAL MASS=11.75 kg

PARTS LIST				
ITEM	QTY	PART NUMBER	REV No	DESCRIPTION
1	1	8183	A	parallel link bush shaft 104mm
2	3	8184	A	parallel link bush shaft 24mm
3	8	8185	A	Bush Steel Teflon TFF20x21.5
4	1	8725.as1	A	Adjustable parallel link nut end
5	2	11688	B	parallel link bush shaft
6	1	12796	A	OD25xID12.5x6 Bush
7	1	12877	B	Inrow twin rotor mount bracket
8	1	12878	A	Parallel Link - Top Hat bush type
9	1	12879	B	twin rotor short reach slotted bracket
10	1	12880	A	Adjustable parallel link bolt end
11	1	12881	B	Adjustable parallel link bolt end
12	1	Bolt "M12 x 40 set Bzp		Hex Head set screw 8.8 BZP
13	1	Bolt M12 x 50 C/sunk Allen head Bzp		Bolt Countersunk Allen head 8.8 Bzp
14	1	Bolt M12 x 50 set Bzp		Hex Head set screw 8.8 BZP
15	1	Bolt M12 x 55 C/sunk Allen head Bzp		Bolt Countersunk Allen head 8.8 Bzp
16	1	Bolt M12 x 140 Bzp		Hex Head Bolt 8.8 BZP
17	2	Bolt M12 x 150 C/sunk Allen head Bzp		Bolt Countersunk Allen head 8.8 Bzp
18	1	Nut Half M12 Bzp		Half Nut Bzp
19	8	Nut nyloc M12		Hex Nut Nyloc Std thread
20	2	Washer flat M 12 thin form B Bzp		Washer Flat Thin form B Bzp
21	2	Washer flat M 12 form A Bzp		Washer Flat form A Bzp
22	7	WASHER RET FLAT M 12X37X3 BZP		Washer Large Od Bzp