



TABLE OF CONTENTS

Section	Item	Page
1	Introduction	5
2	Safety	6
	General Safety	6
	Safety in Operation	6
	Safety with Maintenance	7
	Safety in Transport	7
3	Decals	8
	Safety Decals	8
	Maintenance Decals	8
4	Start-up	9
	Basic Start-up Procedures	9
5	Maintenance	10
6	Storage	11
7	Specifications	12
8	Parts List	13
	Dump Trailer P-508/3S	13
	Dump Trailers P-510/3S	15
	Dump Trailer P-50710/4E	18
	Electric Hydraulic Pump P-510-PHE	21
	Electric circuit.....	22
	Hub H4000	23
	Hub H5000	24
	Directional Control Valve DFC40	25
	Telescopic Cylinder # 51506	26
	Power Pack # 51536	27
9	Torque Chart	29
10	Warranty	30

INTRODUCTION

1

CONGRATULATIONS!

Thank you for choosing PRONOVOST. We are confident this equipment will meet your requirements in terms of quality, performance and reliability.

This manual was prepared to assist you in the safe operation of your new Dump Trailer. It contains important information which will help you achieve excellent returns with your PRONOVOST Dump Trailer for years to come.

Please read this manual before operating your Trailer and keep it for future reference.

Before using this equipment, you or any other person who will be using it must familiarize yourself with the safety recommendations, the operating and safety instructions. Please read carefully and be sure to understand and follow all recommendations and procedures.

In this manual, the right and left sides are identified while standing at the rear end of the equipment and facing it.

If you require additional information on your Dump Trailer, please contact your PRONOVOST Dealer.

NOW take a moment to enter the model, serial number and the date of purchase of your Trailer in the space provided below.

When ordering parts from your Dealer, please refer to these numbers for a fast and efficient service. Use PRONOVOST parts for replacement.

The model and serial numbers are on the name plate shown on Fig. 1.

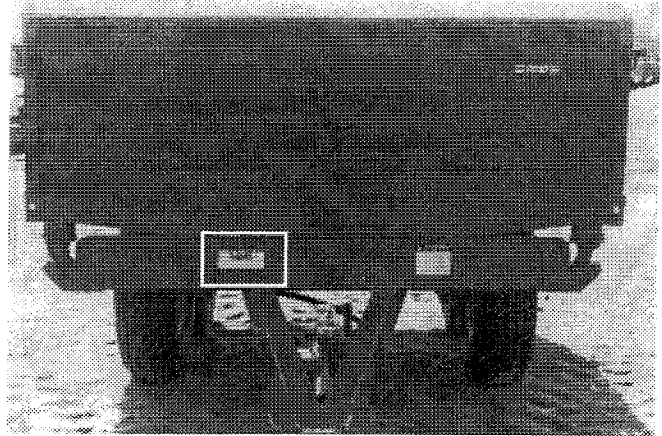

Figure 1

MODEL: _____

SERIAL NO: _____

DATE OF PURCHASE: _____

SAFETY

GENERAL SAFETY

2

WHEN YOU SEE THIS SYMBOL



ATTENTION!

**BE ALERT
YOUR SAFETY IS INVOLVED**

This symbol "SAFETY ALERT" is used in this manual and on the safety decals on the Trailer. It warns you of the possibility of danger. Carefully read, understand and follow all safety recommendations before operating the equipment.

- 1) Careful operation is the best assurance against accidents. Carefully read this manual and follow all recommendations before operating this equipment. It is the owner's responsibility to make sure that anyone who will operate the Trailer will read this manual before operating the equipment.
- 2) Do not modify the equipment. Any non authorized modification may affect the efficiency and/or safety of the equipment.
- 3) Never operate the equipment with defective parts or if damaged in any way. Have it repaired before using it.
- 4) Make sure all fasteners are in place and properly secured or tightened. Refer to torque chart on page 29.
- 5) Hydraulic fluids under pressure can damage your skin. Do not use your hands to locate a leak.
- 6) Battery (with 12V hydraulic system) contains sulfuric acid. Avoid contact with skin, eyes or clothing.

SAFETY IN OPERATION

- 1) **WARNING!** Do not overload your trailer, do not exceed the load capacity indicated in the specifications on page 12.
- 2) Be sure there are no obstructions around the equipment and that no one stands near the equipment when in use.
- 3) Do not operate an engine in a confined or non ventilated area.
- 4) Do not perform any adjustments, cleaning, maintenance or repairs with the engine running on the towing vehicle. Preferably remove the key from the ignition.
- 5) Be careful when backing-up, make sure you have good visibility.
- 6) In the case of a Highway Service Trailer, make sure the suspension, brakes and lights are all functioning properly.
- 7) Do not forget to unlock the proper panel before dumping.
- 8) With the 3-way dump trailers, do not forget to install the pins in the two ball-joints on the side you wish to dump the load, and release the adjacent panel.
- 9) Always travel at a safe operating speed following regulations and common sense. In the case of agricultural service tires, follow the manufacturer's specified safe speed. The road speed should be such as to maintain full control over steering and braking.

SAFETY (cont'd)

SAFETY WITH MAINTENANCE

- 1) Perform maintenance according to recommendations contained in this manual.
- 2) **Before performing any work under the raised platform, always install the safety support provided.**
- 3) If the trailer is hooked up to the tractor while performing maintenance work, make sure the engine is not running and preferably remove the ignition key.

- 2) Be alert while driving on the road. Never carry passengers.

2

SAFETY IN TRANSPORT

- 1) On public roads, use proper safety lights and check local regulations.

DECALS

SAFETY DECALS

The safety decals are affixed wherever special safety precautions are indicated. Locate them on the equipment and read them carefully. If a decal is damaged, lost or illegible, install a new one. The following photos indicate where each one must be installed.

3

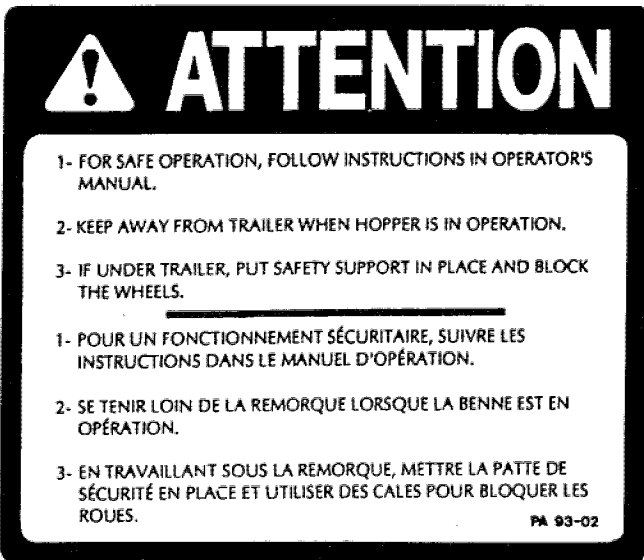

Figure 2
Decal A

Part no.: A110

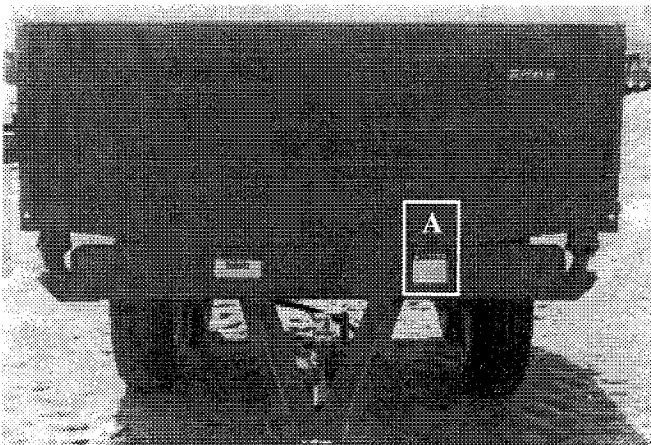

Figure 3

MAINTENANCE DECALS

The maintenance decals indicate the points requiring lubrication. Refer to maintenance section for more details.

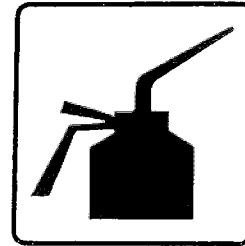

Figure 4

Part no.: A 105

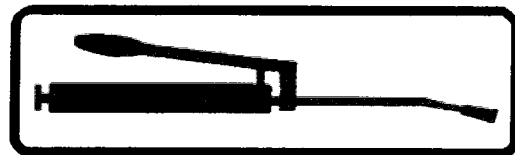

Figure 5

Part no.: A 106

START-UP

BASIC START-UP PROCEDURES

- 1) Lubricate all grease fittings with a good quality multiuse grease.
- 2) Lubricate panel release mechanism, front and rear with good quality oil.
- 3) Adjust tire pressure to manufacturer's specifications.
- 4) Install wheels on hubs.
- 5) Install panels.
- 6) Install all hydraulic hoses and fittings compatible with your equipment.
- 7) Verify for adequate tightness of all fastening devices. Refer to torque chart on page 29.
- 8) Operate the hydraulic system a few times, raising and lowering the platform in order to remove any trapped air in the system. Then check the oil level in the tractor's hydraulic oil reservoir.
- 9) With the 3-way dump trailer, the ball-joint pins are usually installed in a "X" configuration to prevent tipping during handling. They must be installed on the side you wish to dump the load. **ATTENTION: Never use the "X" configuration when using your Dump Trailer.**
- 10) Do not forget to unlock the proper panel before dumping.

4

MAINTENANCE

Before performing any work under the raised platform, always install the safety support provided.

- 1) Wipe off all grease fittings with a clean cloth before adding grease in order to avoid injecting dirt or sand.
- 2) Repair or replace damaged grease fittings.
- 3) Lubricate all grease fittings every 20 hours of operation.
- 4) Check all bolts on wheels after first 5 hours of operation and then every 50 hours of operation.
- 5) Lubricate panel release mechanism, front and rear, every 20 hours of operation.
- 6) Check tire pressure every 50 hours of operation, adjust according to manufacturer's recommendation indicated on the tires.
- 7) Check brakes once a year and adjust or repair if necessary.
- 8) Open, clean and lubricate wheel bearings once a year.
- 9) Check all nuts and bolts once a year. If necessary use torque chart on page 29.

5

STORAGE

- 1) Store in a cool, dry place.
- 2) Install wooden blocks under the axles to keep the tires off the ground and cover them if left exposed to the sun.
- 3) Keep all piston rods in the retracted position. This will assure better protection against the elements.
- 4) Clean your trailer.
- 5) Thoroughly inspect all parts of the trailer. Replace or repair worn or defective parts.
- 6) Touch-up or repaint if necessary.
- 7) Lubricate all points before storage.

SPECIFICATIONS

SERVICE	AGRICULTURAL	AGRICULTURAL	HIGHWAY
MODEL	P-508/3S	P-510/3S	P-50710/4E
Gross weight	4 tons	5 tons	3.5 tons
Width x length interior of box	62" x 99"	62" x 99"	62" x 99"
Thickness of floor	3/16"	3/16"	3/16"
Side panel height 12G *	14"	14"	14"
Front/back panel height 12G *	19"	19"	19"
Platform height	33"	33"	34"
Overall length	138"	138"	138"
Overall width	68"	68"	68"
Overall height	63"	63"	64"
Free height / maximum lift	20"	20"	21"
Thread width	51"	51"	52 1/2"
Dumping angle (back)	47°	47°	47°
Dumping angle (2 sides)	47°	47°	47°
Central unloading hatch	option	option	option
Axle	Single	Tandem	Tandem
Suspension	--	--	Springs
Hubs	6 bolts	6 bolts	5 bolts
Hub capacity	5000 lbs	4000 lbs	1750 lbs
Spindles	2 1/4"	2"	--
Wheels	2	4	4
Wheel dimensions	15 x 8 x 6	15 x 8 x 6	14" x 6"
Tires (standard)	11L15 (8 ply)	11L15 (8 ply)	ST205/75R14
Hitch: clevis/swivel	standard	standard	option
Hitch: ball coupler (2 5/16")	option	option	standard
Electric brakes	--	--	standard
Security chain	option	option	standard
Electric power pack	option	option	option
Battery rack	option	option	standard
Light system (12 V)	--	--	standard
Oil / volume required	5 L	5 L	5 L
Cylinder	1 single acting	1 single acting	1 single acting
Hitch weight (empty)	125 lbs	125 lbs	125 lbs
Total weight	1775 lbs	1850 lbs	1850 lbs

Design and specifications subject to change without notice.

* Removable

DUMP TRAILER P-508/3S

170-02301R1

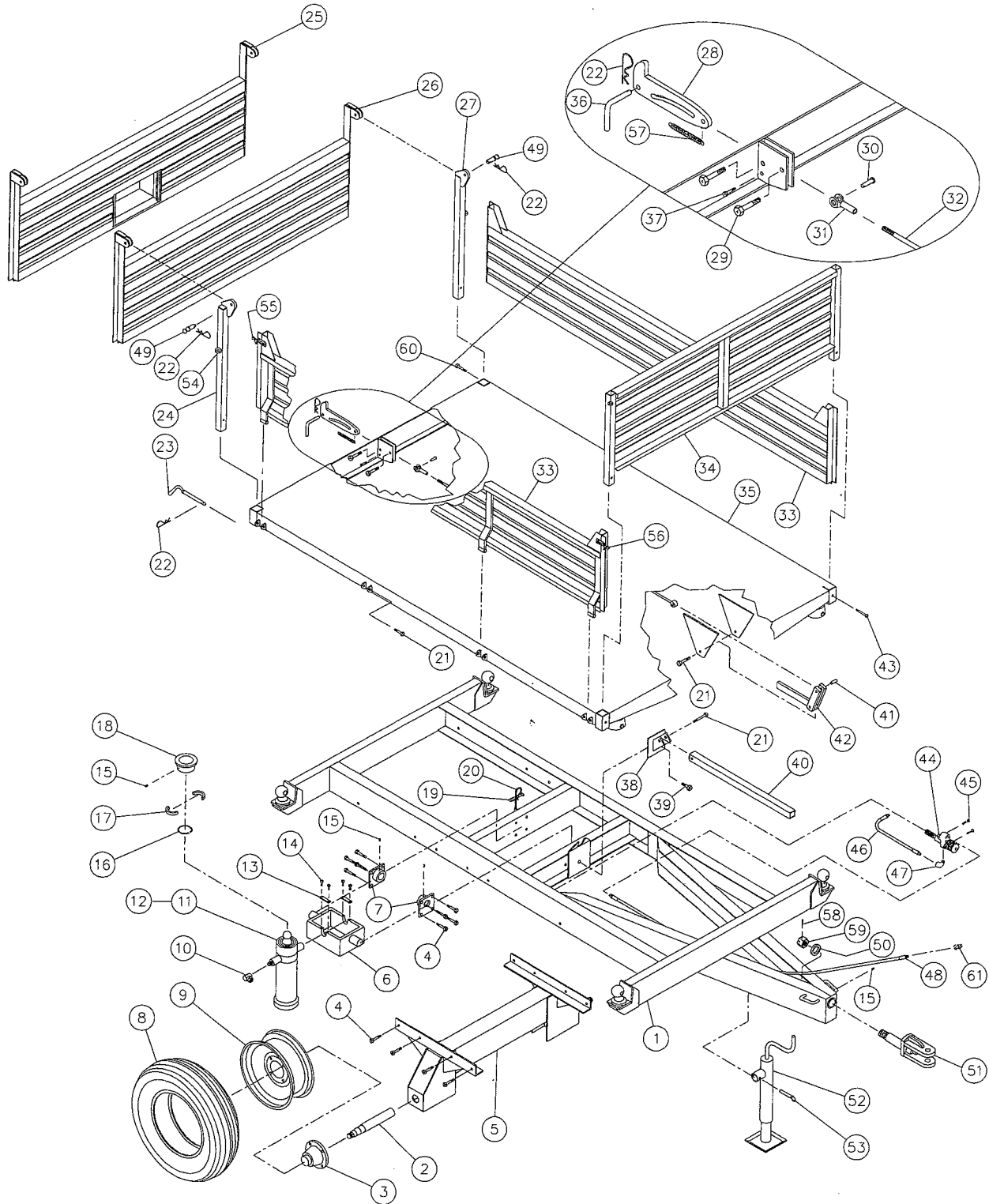

8

DUMP TRAILER P-508/3S (cont'd)

REF.	PART #	DESCRIPTION	QTY
1	120-02231	Frame	1
2	150-00312	Axle 2 1/4" ø (welded)	2
3	51441	Hub # H-5000 complete (see details 24)	2
4	300-40310	Bolt 1/2" NC x 1 1/2" lg + nylon locknut	16
5	110-08962	Cross-beam (including # 2)	1
6	51610	Cylinder gimbal	1
7	110-09041	Pivot plate	2
8	PN-11L15	Tire 11L15 - 8 ply with tube	2
9	R-1586	Rim 15" x 8" - 6 holes	2
10	9455-8x8	Elbow (swivel)	1
11	51506	Telescopic cylinder 3 sections (see details page 26)	1
12	51527	Repair kit for cylinder no. 51506 (see details page 26)	1
13	51572	Retaining plate for cylinder gimbal	2
14	51573	Metric bolt 8 x 20 x 1.25 mm	4
15	Std.	Grease fitting 1/4" - 28 straight	4
16	51574	Retaining ring 2 5/8" int.	1
17	51575	Locking segments for ball-joint 2 7/8"	2
18	51576	Ball joint seat (welded) 4 1/2"	1
19	Std.	Cable clamp 3/16"	2
20	190-03031	Cable 3/16" x 72"	1
21	300-40400	Bolt 1/2" NC x 3" lg + nylon locknut	10
22	Std.	Hitch pin clip 5/32"	5
23	150-00721	Pin for platform pivot	2
24	110-14391	Right rear stake	1
25	120-00522	Rear panel with grain door	opt.
26	110-02772	Standard rear panel	1
27	110-14461	Left rear stake	1
28	130-16211	Rear panel lock	1
29	300-40340	Bolt 1/2" NC x 2" lg + nylon locknut	2
30	51436	Pin 1/2" ø x 1 3/4" lg	1
31	51435	Clevis 1/2" - 20 NF + nut	1
32	110-14541	Rod 1/2" for rear panel lock	1
33	110-11541	Side panel	2
34	110-11532	Front panel	1
35	120-01652	Platform	1
36	150-02861	Pin for rear locking mechanism	1
37	300-34325	Bolt 5/16" NC x 1 3/4" lg + nylon locknut	1
38	110-11561	Safety support bracket	1
39	300-44310	Bolt 5/8" NC x 1 1/2" lg + nylon locknut	1
40	160-05971	Safety support	1
41	150-02761	Pin 1/2" x 1 1/2" lg	1
42	110-14271	Lever for automatic locking mechanism	1
43	300-36370	Bolt 3/8" NC x 2 1/2" lg + nylon locknut	2
44	644-10000	Directional control valve 3/8" NPT (cyl. travel limit) (see details page 25)	1
45	300-34280	Bolt 5/16" NC x 1 1/4" lg + nut & lock washer	2
46	190-03041	Hose R1 3/8" x 21" lg + 1 fitting 6U 106 & 1 fitting 6U 108	1
47	3409-6x6	Street elbow 3/8" (male - female)	1
48	190-03051	Hose R1 3/8" x 114" lg + 1 fitting 6U 106 & 1 fitting 6U 108	1
49	150-02851	Hinge pin for rear panel	2
50	130-20331	Flat washer 1 5/8" i.d. x 2 1/4" o.d.	1
51	110-08991	Swivel hitch	1
52	51490	Jack 3000 lbs (includes # 53)	1
53	51408	Pin for jack	1
54	51583	Ring for side panel lock (welded)	4
55	51584-G	Side panel lock (L.H.) (welded)	2
56	51584-D	Side panel lock (R.H.) (welded)	2
57	190-02351	Spring 3/4" o.d. x 4 1/2"	1
58	Std.	Cotter pin 1/4" x 3"	1
59	357-57000	Castle nut 1 1/2" NC	1
60	300-36370	Bolt 3/8" NC x 2 1/2" lg	2
61	Std.	Quick coupler 1/2" male	1

8

DUMP TRAILER P-510/3S

170-02313R1

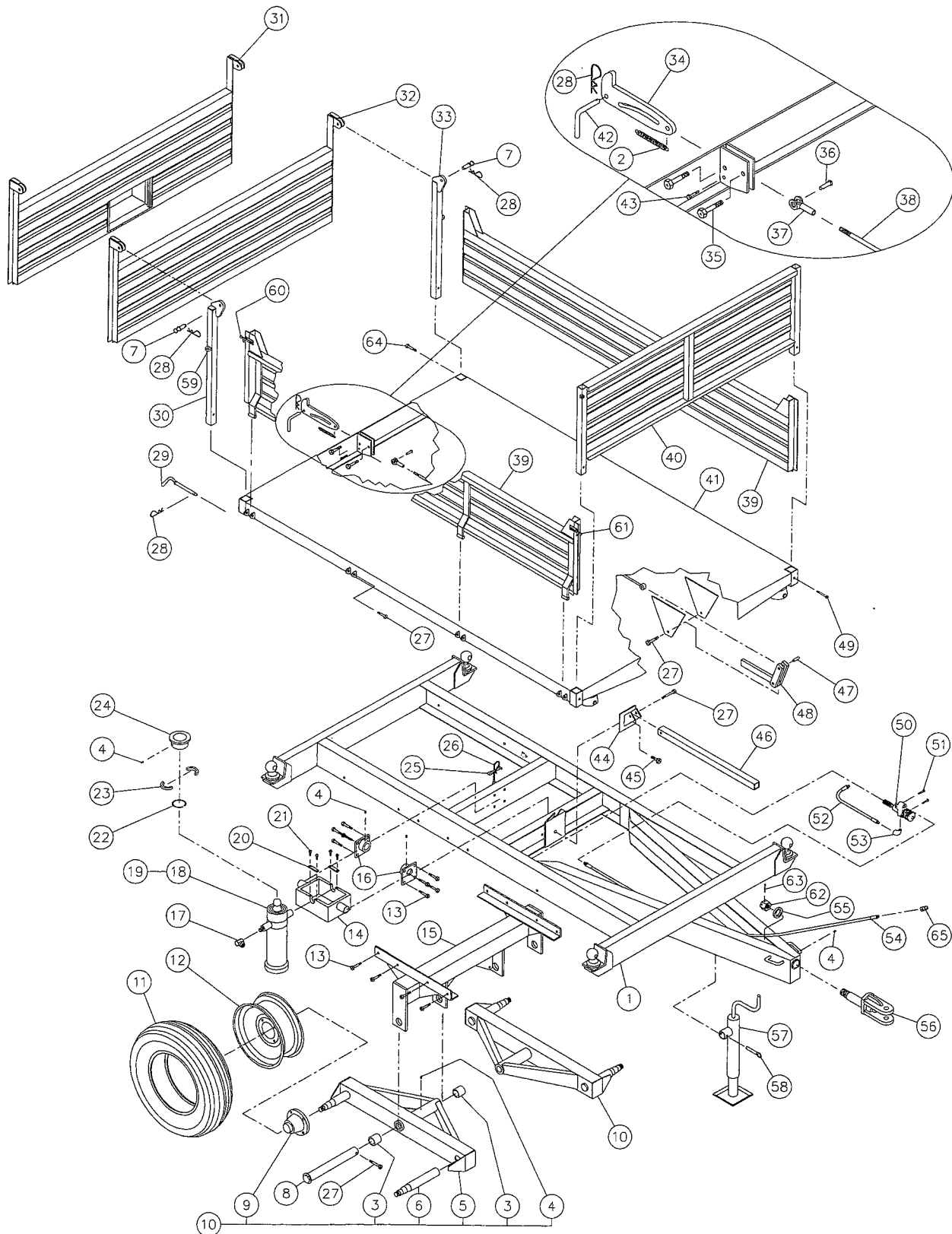

8

DUMP TRAILER P-510/3S (cont'd)

REF.	PART #	DESCRIPTION	QTY
1	120-02231	Frame	1
2	190-05351	Spring 3/4" d.e. x 4 1/2" lg	1
3	160-01091	Brass bushing 1 3/4" i.d. x 2" o.d. x 2" lg	4
4	Std.	Grease fitting 1/4"-28 straight	6
5	110-11412	Tandem frame	2
6	150-02282	Axle 2" ø (welded)	4
7	150-02851	Hinge pin for rear panel	2
8	110-00011	Pin for tandem	2
9	51503	Hub # H-4000 complete (see details page 23)	4
10	110-11414	Tandem assembly (including 3, 4, 5, 6 & 9)	2
11	PN-11L15	Tire 11L15 - 8 ply	4
12	R-1586	Rim 15" x 8" - 6 holes	4
13	300-40310	Bolt 1/2" NC x 1 1/2" lg + nylon locknut	16
14	51610	Cylinder gimbal	1
15	110-11421	Cross-beam	1
16	110-09041	Pivot plate	2
17	9455-8x8	Elbow (swivel)	1
18	51506	Telescopic cylinder 3 sections (see details page 26)	1
19	51527	Repair kit for cylinder no. 51506 (see details page 26)	1
20	51572	Retaining plate for cylinder gimbal	2
21	51573	Metric bolt 8 x 20 x 1.25 mm	4
22	51574	Retaining ring	1
23	51575	Locking segments for ball-joint	2
24	51576	Ball-joint seat (welded)	1
25	Std.	Cable clamp 3/16"	2
26	190-03031	Cable 3/16" x 72"	1
27	300-40400	Bolt 1/2" NC x 3" lg + nylon locknut	12
28	Std.	Hitch pin clip 5/32"	5
29	150-00721	Pin for platform pivot	2
30	110-14391	Right rear stake	1
31	120-00522	Rear panel with grain door	opt.
32	110-02772	Standard rear panel	1
33	110-14461	Left rear stake	1
34	130-16211	Rear panel lock	1
35	300-40340	Bolt 1/2" NC x 2" lg + nylon locknut	2
36	51436	Pin 1/2" ø x 1 3/4" lg	1
37	51435	Clevis 1/2" - 20 NF + nut	1
38	110-14541	Rod 1/2" for rear panel lock	1
39	110-11541	Side panel	2
40	110-11532	Front panel	1
41	120-01652	Platform	1
42	150-02861	Pin for rear locking mechanism	1
43	300-34325	Bolt 5/16" NC x 1 3/4" lg + nylon locknut	1
44	110-11561	Safety support bracket	1
45	300-44310	Bolt 5/8" NC x 1 1/2" lg + nylon locknut	1
46	160-05971	Safety support	1
47	150-02761	Pin 1/2" x 1 1/2" lg	1
48	110-14271	Lever for automatic locking mechanism	1
49	300-36370	Bolt 3/8" NC x 2 1/2" lg + nylon locknut	2
50	644-10000	Directional control valve 3/8" NPT (cyl. travel limit) (see details page 25)	1

8

DUMP TRAILER P-510/3S (cont'd)

REF.	PART #	DESCRIPTION	QTY
51	300-34280	Bolt 5/16" NC x 1 1/4" lg + nylon locknut	2
52	190-03041	Hose R1 3/8" x 21" lg + 1 fitting 6U 106 & 1 fitting 6U 108	1
53	3409-6x6	Street elbow 3/8"	1
54	190-03051	Hose R1 3/8" x 114" lg + 1 fitting 6U 106 & 1 fitting 6U 108	1
55	130-20331	Flat washer 1 5/8" i.d. x 2 1/4" o.d.	1
56	110-08991	Swivel hitch	1
57	51490	Jack 3000 lbs (includes # 58)	1
58	51408	Pin for jack	1
59	51583	Ring for side panel lock (welded)	4
60	51584-G	Side panel lock (L.H.) (welded)	2
61	51584-D	Side panel lock (R.H.) (welded)	2
62	Std.	Castle nut 1 1/2" NC	1
63	Std.	Cotter pin 1/4" x 3" lg	1
64	300-36370	Bolt 3/8" NC x 2 1/2" lg	2
65	Std.	Quick coupler 1/2" male	1

DUMP TRAILER P-50710/4E

170-02325R1

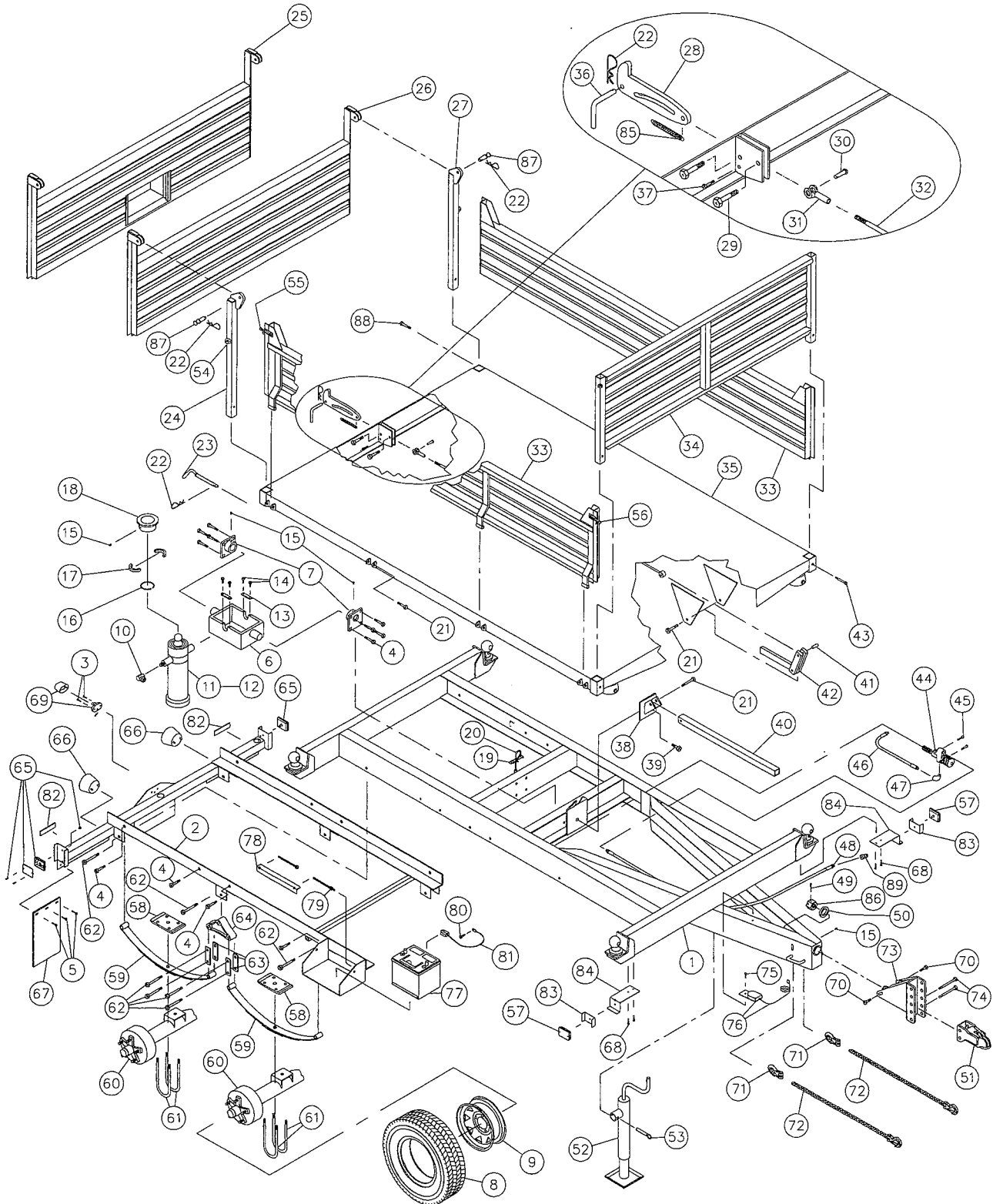

8

DUMP TRAILER P-50710/4E (cont'd)

REF.	PART #	DESCRIPTION	QTY
1	120-02231	Main frame for P-50710/4E	1
2	120-02371	Frame to fasten road axle and lights	1
3	300-20250	Bolt 10-24 x 1" lg + nylon locknut	2
4	300-40310	Bolt 1/2" NC x 1 1/2" lg + nylon locknut	16
5	300-32250	Bolt 1/4" NC x 1" lg + nylon locknut + flat washer	6
6	51610	Cylinder gimbal	1
7	110-09041	Pivot plate	2
8	PN-2057514	Road tire P205/75R14	4
9	RM1465	Rim 14 x 6 - 5 bolts	4
10	9455-8x8	Elbow (swivel)	1
11	51506	Telescopic cylinder 3 sections (see details page 26)	1
12	51527	Repair kit for cylinder no. 51506 (see details page 26)	1
13	51572	Retaining plate for cylindrer gimbal	2
14	51573	Metric bolt 8 x 20 x 1.25 mm	4
15	Std.	Grease fitting 1/4" - 28 straight	4
16	51574	Retaining ring 2 5/8" int.	1
17	51575	Locking segments for ball-joint 2 7/8"	2
18	51576	Ball-joint seat (welded) 4 1/2"	1
19	Std.	Cable clamp 3/16"	2
20	190-03031	Cable 3/16" x 72"	1
21	300-40400	Bolt 1/2" NC x 3" lg + nylon locknut	10
22	Std.	Hitch pin clip 5/32"	5
23	150-00721	Pin for platform pivot	2
24	110-14391	Right rear stake	1
25	120-00522	Rear panel with grain door	opt.
26	110-02772	Standard rear panel	1
27	110-14461	Left rear stake	1
28	130-16211	Rear panel lock	1
29	300-40340	Bolt 1/2" NC x 2" lg + nylon locknut	2
30	51436	Pin 1/2" ø x 1 3/4" lg	1
31	51435	Clevis 1/2" NF + nut	1
32	110-14541	Rod 1/2" for rear panel lock	1
33	110-11541	Side panel	2
34	110-11532	Front panel	1
35	120-01652	Platform	1
36	150-02861	Pin for rear locking mechanism	1
37	300-34325	Bolt 5/16" NC x 1 3/4" lg + nylon locknut	1
38	110-11561	Safety support bracket	1
39	300-44310	Bolt 5/8" NC x 1 1/2" lg + nylon locknut	1
40	160-05971	Safety support	1
41	150-02761	Pin 1/2" x 1 1/2" lg	1
42	110-14271	Lever for automatic locking mechanism	1
43	300-36370	Bolt 3/8" NC x 2 1/2" lg + nylon locknut	2
44	644-10000	Directionnal control valve 3/8" NPT (cyl. travel limit) (see details page 25)	1
45	300-34280	Bolt 5/16" NC x 1 1/4" lg + nylon locknut	2
46	190-03041	Hose R1 3/8" x 21" lg + 1 fitting 6U 106 & 1 fitting 6U 108	1
47	3409-6x6	Street elbow 3/8" (male - female)	1
48	190-03051	Hose R1 3/8" x 114" lg + 1 fitting 6U 106 & 1 fitting 6U 108	1
49	Std.	Cotter pin 1/4" x 3" lg	1
50	130-20331	Flat washer 1 5/8" i.d. x 2 1/4" o.d.	1
51	51615	Ball hitch 2 5/16"	1
51	51525	Swivel hitch	opt.
51	110-07161	Pintle hitch 3" ø int.	opt.
52	51490	Jack 3000 lbs (includes # 53)	1
53	51408	Pin for jack	1
54	51583	Ring for side panel lock (welded)	4

8

DUMP TRAILER P-50710/4E (cont'd)

RÉF.	# DE PIÈCE	DESCRIPTION	QTE
55	51584-G	Side panel lock (L.H.) (welded)	2
56	51584-D	Side panel lock (R.H.) (welded)	2
57	52077	Parking light (yellow)	2
58	51599	Spring fixation plate	4
59	51600	Springs	4
60	110-06671	Road axle with hub and brakes	2
61	Std.	U-bolt 1/2" NF x 3" x 7" round + 2 nylon locknut	8
62	300-42400	Bolt 9/16" NC x 3" lg + nylon locknut	14
63	51601	Pivot plate	8
64	51602	Pivot	2
65	52076	Parking light (red)	2
66	32229	Rear flasher light	2
67	51612	Mudguard 8" x 14"	2
68	316-32220	Teck screw 1/4-14 x 3/4" lg	4
69	52070	Light for license plate	1
70	301-38280	Bolt 7/16" NC x 1 1/4" lg + nylon locknut + 2 flat washers	2
71	54070	Hook with safety lock	2
72	54064	Chain 5/16" (10000 lbs) + hook with safety lock	2
73	110-14052	Adjustable mounting support for ball hitch	1
74	302-44490	Bolt 5/8" NF x 4 1/2" lg + nylon locknut	2
75	300-32220	Bolt 1/4" NC x 3/4" lg + nylon locknut	1
76	52069	Emergency brake switch	1
77	51614	Battery 12 V 850A	1
78	130-05751	Angle	1
79	110-04841	Tightener + 1 nylon locknut 3/8" NC + 1 nylon locknut 7/16" NC	2
80	300-36250	Bolt 3/8" NC x 1" lg + nylon locknut	1
81	51607	Battery cable 4 Ga x 10" lg	1
82	52074	Self-adhesive reflector 1 1/8" x 4 1/2" (red)	2
83	130-13371	Parking light guard	2
84	130-13441	Parking light support	2
85	190-02351	Spring 3/4" o.d. x 4 1/2" lg	1
86	357-57000	Castle nut 1 1/2" NC	1
87	150-02851	Hinge pin for rear panel	2
88	300-36370	Bolt 3/8" NC x 2 1/2" lg	2
89	Std.	Quick coupler 1/2" male	1

ELECTRIC HYDRAULIC PUMP P-510-PHE

170-00961

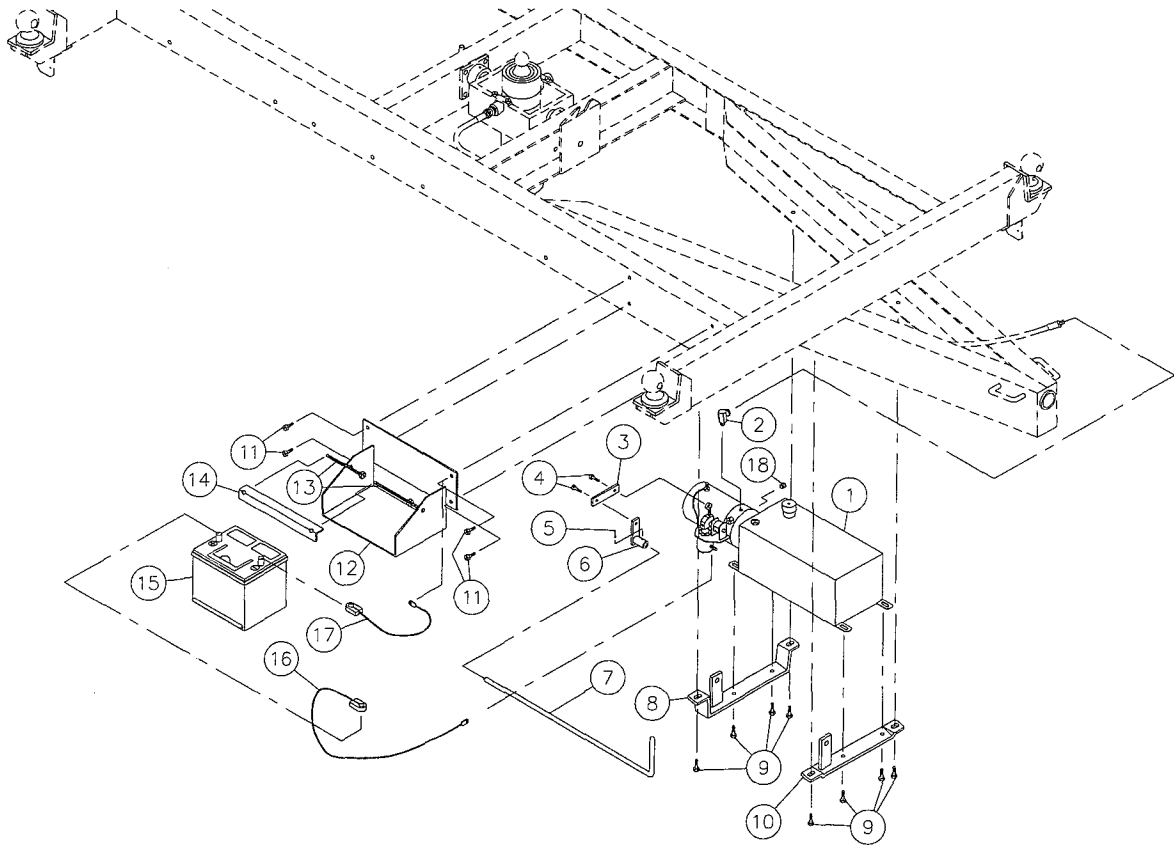

REF.	PART #	DESCRIPTION	QTY	
			P-508/3S P-510/3S	P-50710/4E
1	613-00000	Electric hydraulic pump	1	1
2	9405x6x6	Fitting 90°	1	1
3	140-05011	Connecting rod	1	1
4	300-34280	Bolt 5/16" NC x 1 1/4" lg + nylon locknut	2	2
5	Std.	Roll pin 1/8" x 1"	1	1
6	110-06801	Pivot	1	1
7	150-01381	Handle 26" lg	1	1
8	110-06781	Rear support (for pump)	1	1
9	300-36310	Bolt 3/8" NC x 1 1/2" lg + nylon locknut & flat washer	8	8
10	110-06791	Front support (for pump)	1	1
11	300-36250	Bolt 3/8" NC x 1" lg + nylon locknut	4	-
12	110-06772	Battery holder	1	-
13	110-04841	Threaded rod + 1 nylon locknut 3/8" NC + 1 nylon locknut 7/16" NC	2	-
14	130-05751	Angle	1	-
15	51614	Battery 12 volts 850 Amp	opt.	-
16	51606	Battery cable 4G x 30" lg	1	1
17	51607	Battery cable 4G x 16" lg	1	-
18	C1359x4	Cap 1/4" NPTM	1	1

8

ELECTRIC CIRCUIT P-50710/4E

170-01731

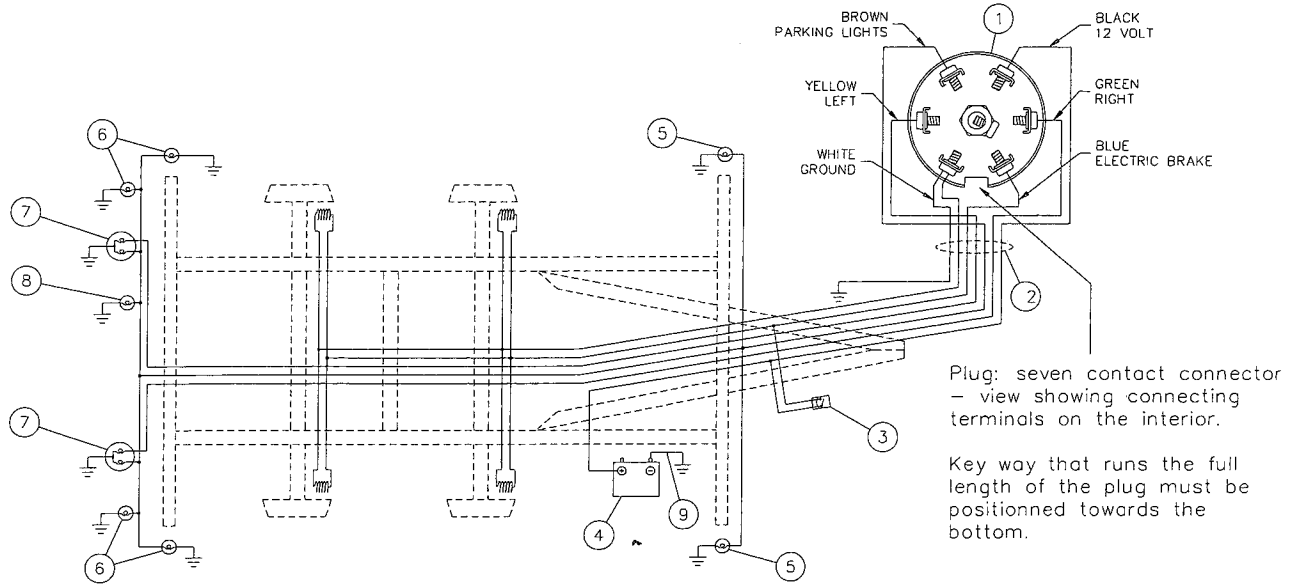

REF.	PART #	DESCRIPTION	QTY
1	52065	Connector 7 poles (trailer side)	1
2	51609	P-50710/4E conductors cable kit	1
3	52069	Emergency brake	1
4	51614	Battery 12 volts 850 Amp	1
5	52077	Yellow parking lights	2
6	52076	Red parking lights	2
7	32229	Flashers	2
8	52070	License light	1
9	51607	Battery cable 4 GA x 10" lg	1
NI	52078	Connector 7 poles (vehicle side)	1

8

HUB H4000

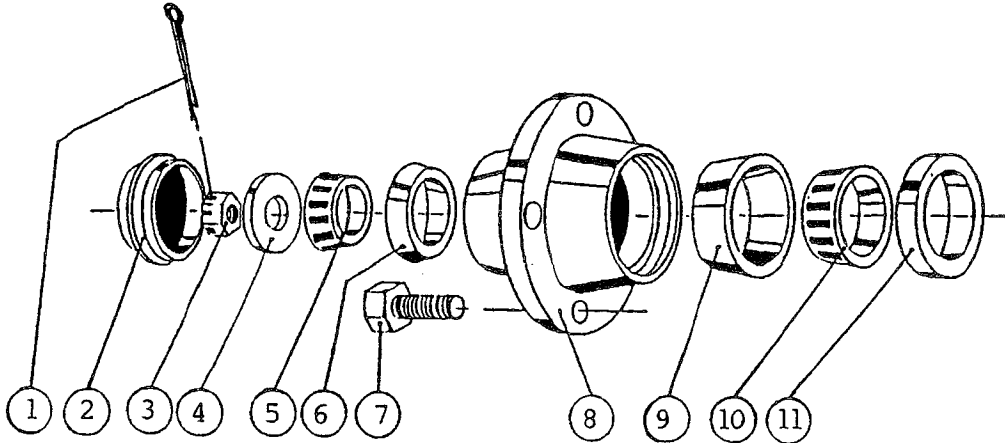

REF.	PART #	DESCRIPTION	QTY
1	Std.	Cotter pin 5/32" x 1 3/4"	1
2	51528	Dust cap D-4000 2 5/16" ø	1
3	51529	Castle nut 1" NF x 9/16" thick	1
4	Std.	Flat washer 1"	1
5	51530	Roller bearing Timken: cone no. LM67048	1
6	51531	Roller bearing Timken: cup no. LM67010	1
7	51418	Rim screw 9/16"	6
8	51532	Hub only H4000	1
9	51533	Roller bearing Timken: cup no. LM29710	1
10	51534	Roller bearing Timken: cone no. LM29749	1
11	51535	Oil seal no. CR17415	1

8

HUB H5000

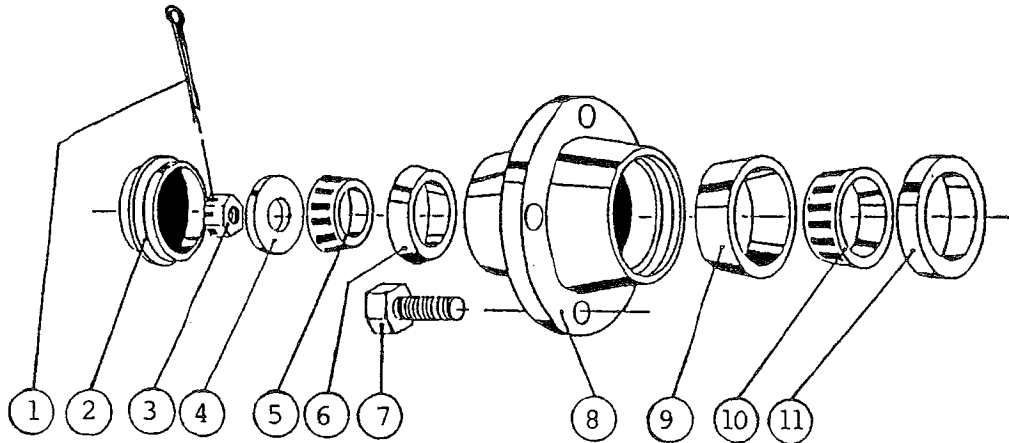

REF.	PART #	DESCRIPTION	QTY
1	Std.	Cotter pin 5/32" x 1 1/2"	1
2	51417	Dust cap 2.570" ø	1
3	51442	Castle nut 7/8" NF	1
4	Std.	Flat washer 7/8"	1
5	51416	Roller bearing Timken: cone no. 4T-LM48548	1
6	51415	Roller bearing Timken: cup no. 4T-LM48510	1
7	51418	Rim screw 9/16"	6
8	51414	Hub only H5000	1
9	51413	Roller bearing Timken: cup no. 4T-LM603011	1
10	51412	Roller bearing Timken: cone no. 4T-LM603049	1
11	51443	Oil seal no. CR20044	1

8

TELESCOPIC CYLINDER # 51506

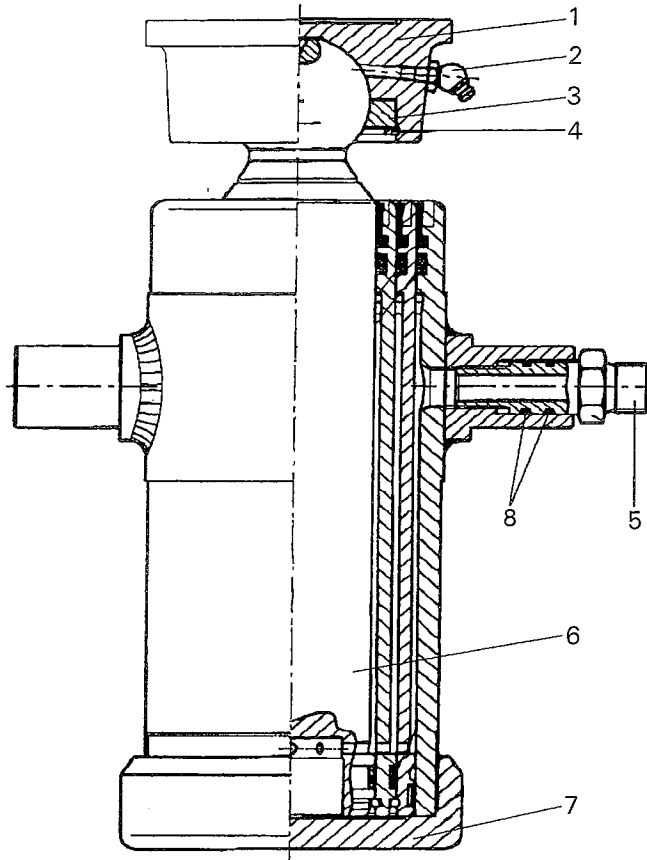

8

REF.	PART #	DESCRIPTION	QTY
1	51576	Ball joint seat (welded)	1
2	Std.	Grease fitting 1/4"-28 straight	1
3	51575	Locking segments for ball-joint 2 7/8"	1
4	51574	Retaining ring (interior), 3.175"	1
5	51586	Connector	1
6	51587	Piston with ball	1
7	51588	Threaded cylinder base	1
8	51589	Seal kit for connector	1
NI*	51527	Repair kit for cylinder	1

*NI = Not illustrated

* Some parts might not be available apart.

POWER PACK # 51536

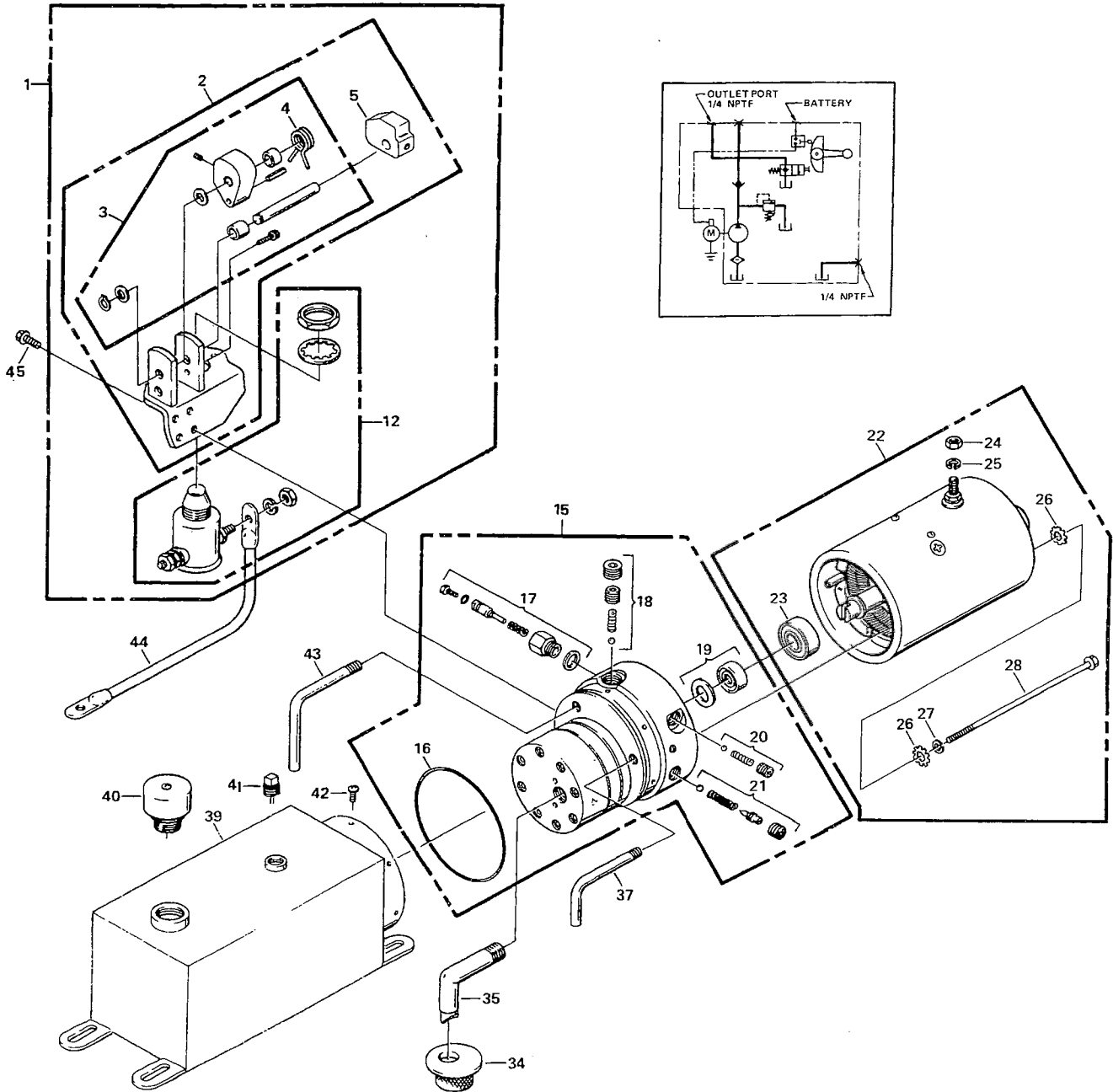







POWER PACK # 51536 (cont'd)

REF.	PART #	DESCRIPTION	QTY
1	51537	Bracket assembly with mounting plate and start switch	1
2	51538	Bracket assembly with mounting plate	1
3	51539	Bracket assembly only	1
4	51540	Torsion spring	1
5	51541	Block	1
12	51542	Start switch	1
15	51543	Pump assembly (gear code 05)	1
16	51544	Industrial o-ring (3 5/8" x 3 7/8" x 1/8")	1
17	51545	Plunger	1
18	51546	Main check valve	1
19	51547	Seal and gasket	1
20	51548	Descending check valve	1
21	51549	Relief valve	1
22	51550	Electric motor 12V DC	1
23	51551	Ball bearing	1
24	Std.	Nut 5/16"-24	1
25	Std.	Lock washer 5/16"	1
26	Std.	Star washer 1/4"	4
27	Std.	Lock washer 1/4"	2
28	Std.	Bolt 1/4"-20 x 6 1/2"	2
34	51552	Filter	1
35	51553	Filter (suction tube) 3/8" NPT 90°	1
37	51554	Return tube 1/8"	1
39	51555	Reservoir 6 1/4" x 7" x 15", 510 in ³ usable	1
40	51556	Vent plug	1
41	51557	Square head plug	1
42	Std.	Screw 10-24 x 3/8"	6
43	51558	Return tube (1/8 NPT)	1
44	51559	Insulated cable with lugs 9" 6 gauge	1
45	Std.	Flange hex. head screw (tap tite) 1/4"-20 x 5/8"	4





* Some parts might not be available apart.

TORQUE CHART

TORQUE SPECIFICATION TABLE

Thread UNC and UNF		Grade 2 				Grade 5   				Grade 8*   			
Bolt size		Torque				Torque				Torque			
Inches	mm	Pound feet		Newton meters		Pound feet		Newton meters		Pound feet		Newton meters	
		min.	max.	min.	max.	min.	max.	min.	max.	min.	max.	min.	max.
1/4	6.35	5	6	6.8	8.13	9	11	12.2	14.9	12	15	16.3	30.3
5/16	7.94	10	12	13.6	16.3	17	20.5	23.1	27.8	24	29	32.5	39.3
3/8	9.53	20	23	27.1	31.2	35	42	47.5	57.0	45	54	61.0	73.2
7/16	11.11	30	35	40.7	47.4	54	64	73.2	86.8	70	84	94.9	113.9
1/2	12.70	45	52	61.0	70.5	80	96	108.5	130.2	110	132	149.2	179.0
9/16	14.29	65	75	88.1	101.6	110	132	149.2	179.0	160	192	217.0	260.4
5/8	15.88	95	105	128.7	142.3	150	180	203.4	244.1	220	264	298.3	358.0
3/4	19.05	150	185	203.3	250.7	270	324	366.1	439.3	380	456	515.3	618.3
7/8	22.23	160	200	216.8	271.0	400	480	542.4	650.9	600	720	813.6	976.3
1	25.40	250	300	338.8	406.5	580	696	786.5	943.8	900	1080	1220.4	1464.5
1 1/8	25.58	-	-	-	-	800	880	1084.8	1193.3	1280	1440	1735.7	1952.6
1 1/4	31.75	-	-	-	-	1120	1240	1518.7	1681.4	1820	2000	2467.9	2712.0
1 3/8	34.93	-	-	-	-	1460	1680	1979.8	2278.1	2380	2720	3227.3	3688.3
1 1/2	38.10	-	-	-	-	1940	2200	2630.6	2983.2	3160	3560	4285.0	4827.4

* Thick nuts must be used with grade 8 bolts.

Size of screw	Thread	Pitch (mm)	Grade 4T  				Grade 7T 				Grade 8T  			
			Torque				Torque				Torque			
			Pound feet		Newton meters		Pound feet		Newton meters		Pound feet		Newton meters	
		min.	max.	min.	max.	min.	max.	min.	max.	min.	max.	min.	max.	
M6	UNC	1.00	3.6	5.8	4.9	7.9	5.8	9.4	7.9	12.7	7.2	10	9.8	13.6
M8	UNC	1.25	7.2	14	9.8	19	17	22	23	29.8	20	26	27.1	35.2
M10	UNC	1.5	20	25	27.1	33.9	34	40	46.1	54.2	38	46	51.5	62.3
M12	UNC	1.75	28	34	37.9	46.1	51	59	69.1	79.9	57	66	77.2	89.4
M14	UNC	2.0	49	56	66.4	75.9	81	93	109.8	126	96	109	130.1	147.7
M16	UNC	2.0	67	77	90.8	104.3	116	130	157.2	176.2	129	145	174.8	196.5
M18	UNC	2.0	88	100	119.2	136	150	168	203.3	227.6	175	194	237.1	262.9
M20	UNC	2.5	108	130	146.3	176.2	186	205	252	277.8	213	249	288.6	337.4
M8	UNF	1.0	12	17	16.3	23	19	27	25.7	36.6	22	31	29.8	42
M10	UNF	1.25	20	29	27.1	39.3	35	47	47.4	63.7	40	52	54.2	70.5
M12	UNF	1.25	31	41	42	55.6	56	68	75.9	92.1	62	75	84	101.6
M14	UNF	1.5	52	64	70.5	86.7	90	106	122	143.6	107	124	145	168
M16	UNF	1.5	69	83	93.5	112.5	120	138	162.6	187	140	158	189.7	214.1
M18	UNF	1.5	100	117	136	158.5	177	199	239.8	269.6	202	231	273.7	313
M20	UNF	1.5	132	150	178.9	203.3	206	242	279.1	327.9	246	289	333.3	391.6

Use the above torques when special torque is not given.

NOTE: These values apply to fasteners as received from supplier, dry, or when lubricated with normal engine oil. They do not apply if extreme pressure lubricants are used.

WARRANTY

PRONOVOST warrants this product to the initial purchaser for the period of one year from the date of purchase against defects in materials and workmanship.

We will replace or repair defective parts free of charge if they are returned to our plant in St-Tite, Quebec, Canada.

Transportation charges are the responsibility of the customer. This warranty is not transferable.

Hydraulic cylinders are covered by the manufacturer of these items.

All PRONOVOST spare parts purchased are covered by a three (3) month warranty.

This warranty becomes void and nul if the equipment is modified, breaks down as the result of an accident, is not operated according to manufacturer's recommendations, damaged by negligence or if maintenance has not been carried out as specified.

Our obligation is limited to the replacement or repair of the defective part. PRONOVOST accepts no responsibility for direct or indirect consequential damages of any kind.