

## Conditions of Sale and Warranty

**Chemical Application:** The exclusive remedy of the user or buyer and the limit of the liability of this company or any other seller for any and all losses, injuries or damages resulting from the use, operation or handling of the rotary applicator (including claims based in contract, negligence, strict liability, other tort or otherwise) shall be the purchase price paid by the user or buyer for the rotary atomizer. In no event shall this company or any other seller be liable for any incidental or consequential damages. Further, understanding is that this company or any other seller assumes no responsibility or liability for the effectiveness and the safety of the chemical applied through the MMX. The buyer and all users are deemed to have accepted the terms of this limit of liability which may not be varied by any verbal or written agreement.

# MICROMAX™

## Controlled Droplet Applicator

### Mounting Instructions and Operating Manual

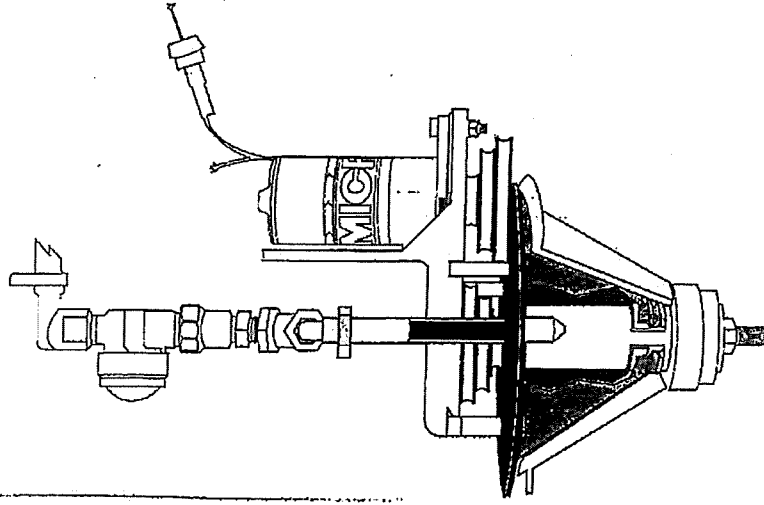

SUPPLIED BY:

# BUBCO

D I S T R I B U T I N G

BUBCO Distributing • 816-B Black Diamond Way • Lodi, CA 95240  
Phone: (209) 367-3885 • Fax: (209) 367-3895 • Web Site: [www.bubco.com](http://www.bubco.com)

™ Micromax is a trademark of Micron Corporation and is a registered trademark of B. I. DuPont Company.  
All other trademarks and registered trademarks are the property of their respective owners. Specifications are subject to change without notice.

# MICRON

## SPRAYERS LIMITED

Three Mills, Bromyard • Herefordshire HR7 4HU • U.K.

## Contents

## Page

Preparing Boom for Mounting	1
Mounting MMX to Boom	1
Electrical Wiring for MMX	2
Spray Application System	3
Controlled Droplet Application	3
Frequently Asked Questions About MMX	4
MMX Spacing	5
Micromax Applicator Speeds	5
Micromax Controlled Droplet Applicator Assembly	6
Plumbing Kit Assembly	8
Determining the Flow Rate	9
Determining Gallons per Acre of Total Spray Solution Applied	10
Calibration for Spraying	11
Pre-Field Instructions	12
Micromax MMX Operating Tips	13
Sprayer Maintenance	13

1. Always turn liquid flow off before switching off an MMX. After an MMX is turned on it should remain on if the sprayer is operating. Control the flow by turning the sprayer valves on and off.
2. It is important not to overfeed an MMX.
3. Operate at low pressures, from 20 to 40 psi.
4. Consider wind direction when spraying.
5. When using MMX speeds of 3,500 rpm or 5,000 rpm, wind movement is beneficial. Recommended air velocity is 5 to 10 mph. You can and should apply pesticides on days that are acceptable for conventional application. Wind will impart lateral movement of the spray pattern, which improves pesticide penetration and coverage of the target area where there is dense foliage. Raise boom height above target area to increase lateral movement.
6. When using MMX speeds of 3,500 rpm to 5,000 rpm the droplets produced are 80 to 150 microns in size and tend to diminish in size due to evaporation. Because of the low volume being used, a suitable anti-evaporant such as Propylene Glycol or crop spray oil should be added to the tank mix. Ten percent of the tank mix should be an anti-evaporant, not to exceed 1 pint per acre. This will help the droplet maintain its size from the time it leaves the MMX until it reaches its target.
7. When using an MMX speed of 2,000 rpm it is recommended that the boom be located as close to the ground surface as is practical, but not so low as to affect spray overlap. The droplet issuing points should be a minimum of 12 inches above the target.
8. Centrifugal pumps should be vented to the spray tank so that the pump becomes self-priming, thereby preventing any loss of spray solution.

### Sprayer Maintenance

1. Check the orifice strainers twice daily and clean them as needed.
2. Check MMX flow rate daily prior to operation. Orifice plates will change in size with use, so adjust the pressure or replace orifice plates if they exhibit wear.
3. Check the drive belts regularly for slippage, and replace the belts yearly or whenever they deteriorate.
4. Electrical connections should be tightened regularly and checked for chemical corrosion.
5. Fuses should be removed from the holders and cleaned periodically. Operating near the spray pattern can cause chemical corrosion that cannot be seen with the eye; therefore, it is necessary to clean fuse contacts regularly.
6. Cup (disc) bearings have Teflon® seals. A new special lubricant is used in them which resists chemical solvents.
7. After spraying, wash the system and run water through the boom and through the entire MMX unit to flush all chemical spray solution from the system. Daily washing is recommended.
8. Wash and clean before storing. If possible, keep the entire system under cover, and cover the individual MF units with plastic.

Step 7 -- Fill the tank according to the pesticide manufacturer's recommendations, and you are ready to begin spraying. Plates are inserted into the spray line of the plumbing kit after the diaphragm check valve and strainer, and before the tee fitting that divides the chemical solution into each side of the MMX. Orifice plates CP4916-55 and CP4916-37 are included with each MMX, however, other orifice plates may be ordered and used to achieve a desired flow rate.

### Pre-Field Instructions

1. Read all instructions carefully.
2. Check all drive belts to see that they are on the proper pulleys. For the 2,000 rpm speed the belts should be on small motor pulleys, for 3,500 rpm the belts should be on the center pulleys, and for the 5,000 rpm speed the belts should be on large motor pulleys. Check that the belt is opposite the proper pulley and level.

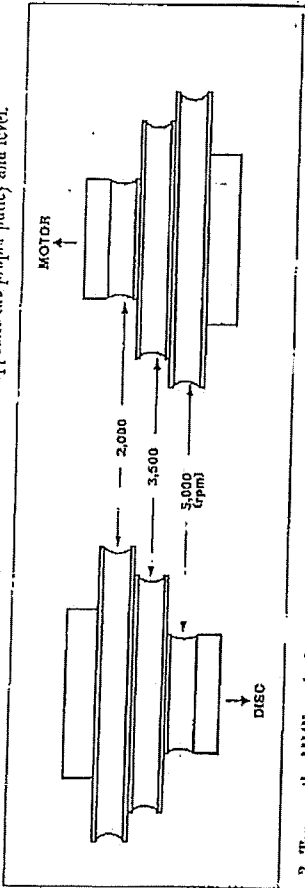

3. Turn on the MMX to check operation and the direction of rotation. Make sure the MMX is spinning in the direction indicated on the motor, counter-clockwise as viewed from the top.
4. Remove the hoses from the MMX units and flush the complete system with water. Clean each MMX to ensure that screens are free from trash. Do not use water containing sand particles. Rust or contaminants within the system will adversely affect performance, and can destroy the system. Keeping the system clean is the key to efficient and effective application.

5. Make sure the proper orifice plates are in place to meter the correct flow rate.
6. Check to see that there are no obstructions to the spray pattern.

7. Check the boom height, and adjust as needed. The MMX will produce the most uniform pattern when operated from 12 to 24 inches above the target, and swath displacement will be less when the spray pattern is low. However, it is important to operate with enough boom height to prevent the MMX from dragging or hitting the ground.

8. At the end of the boom, use a device that drops down far enough to protect and prevent the end of the MMX from dragging or hitting the ground. A narrow Danish Tine extending downward works well, and the spray pattern is disrupted very little by this type of guard.

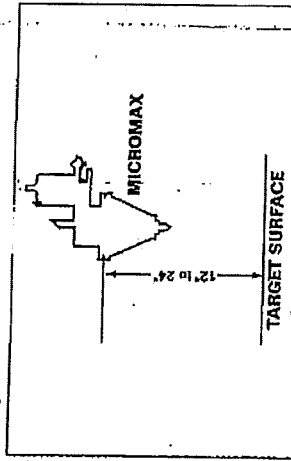

## Micromax Controlled Droplet Applicator Mounting Instructions

### Preparing Boom for Mounting

1. The Micromax Controlled Droplet Applicator (MMX) can be mounted to square, round, or angle iron booms.

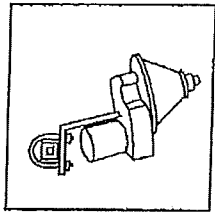

MMX Mounted to Square Boom

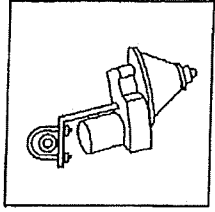

MMX Mounted to Round Boom

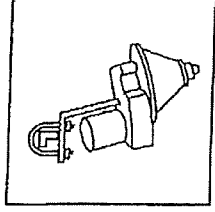

MMX Mounted to Angle Iron Boom

2. The boom should be rigid in construction, and if light in weight, it should be stabilized and reinforced.
3. Boom bounce should be minimized by using brace bars, nylon support ropes or springs.

### Mounting MMX to Boom

1. A drop bracket should be used to lower the MMX below the spray boom. The nozzle is generally set at a 15° angle to the target surface, except for spraying in orchards where a horizontal setting is desirable to prevent injury to trees. Bolt the bracket to the MMX before clamping it to the boom. Be sure to install the bracket to the boom so that the angle fits the MMX to the rear with the motor towards the front. This will direct the spray pattern to its lowest point in the front and its highest point in the rear.

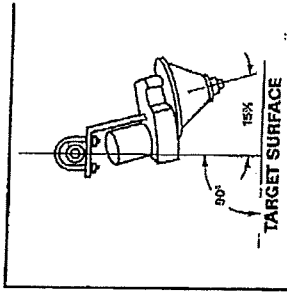

Proper Mounting Ensures Proper Operation

2. Location along the boom depends on the spacing or centers required for your application. The total boom width or swath width can affect spacing to some degree, but 40 inches is usually the ideal spacing.
3. If an odd number of MMX units are used, place the first unit in the center of the sprayer boom, measure from that unit the desired space on either side, and attach the remaining units.
4. If an even number of MMX units are used, locate the center of the sprayer boom, measure half the desired spacing and attach the unit. Proceed out on each side of the boom.

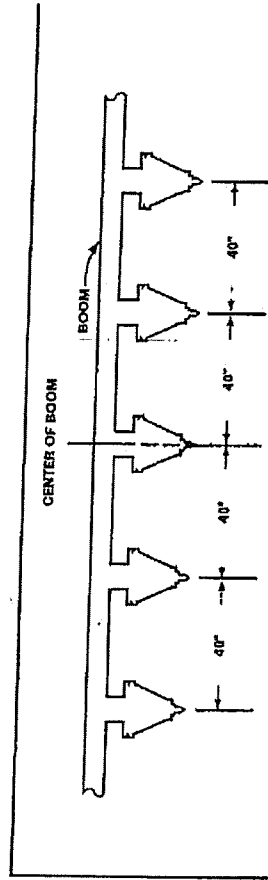

Placing an Odd Number of MMXs on a Boom

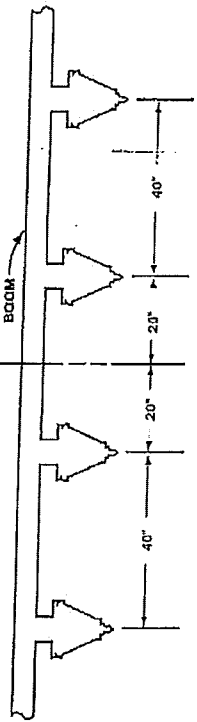

Placing an Even Number of MMXs on a Boom

- To prevent spray pattern disruption, the MMX needs to be located at least 3-1/2 feet from any obstruction along the boom. If there is any obstruction, such as tires, an extension arm needs to be attached to the boom. This arm can be manufactured out of any 1-1/2 inch or larger angle iron. Channel iron and round or square tubing may also be used, as long as they produce an extension arm rigid enough to minimize MMX bounce and long enough to prevent any obstruction of the spray pattern.

### Electrical Wiring for MMX

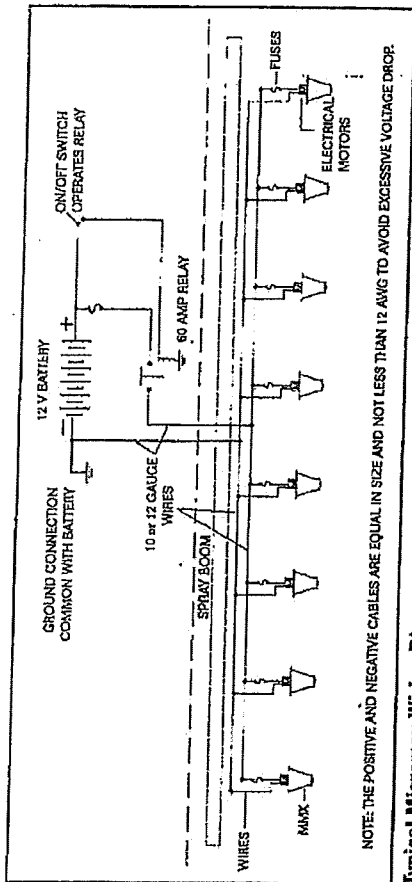

Typical Micromax Wiring Diagram

- Beginning with the motor at the far end of the boom, connect the wires from the fuse holders in parallel by routing a 10 or 12 gauge wire down and along the boom from one MMX motor to the next. A 4 amp, slow-blow fuse (Guss #MDI, 4, Littelfuse #313004 or 3AGAS-B, or equivalent) should be used on each MMX motor to protect it from damage due to an electrical power surge. Fuse holders are not totally moisture or chemical proof, and it is suggested that you wrap the fuse holder with insulating tape.
- If you want the ability to switch each MMX motor on and off individually, place a toggle switch, rated 4 amp or higher, between each fuse and the parallel wiring.
- Splice a wire into the boom wire and connect it to the master power switch. A 60 amp relay switch, properly fused to the tractor battery positive connection, is recommended for power switching.
- Ground wiring of the motor should be done using 10 or 12 gauge wire in a manner similar to that used for the positive wiring, but without fuses or switches and with the boom wiring connected to the tractor battery ground connection.

Step 1 - The amount of chemical solution being fed to each MMX is a constant figure and is achieved by adjusting pressure a orifice size. Flow rate must be determined before calibration can begin. If this has not been determined, refer to the Graph for Determining the Flow Rate of Different Orifice Plates to select the desired orifice plate, and insert the desired orifice plate into place with the printed orifice number toward the MMX, as shown in the Plumbing Kit Diagram on page 8.

Step 2 - To calibrate, remove the hose from the two bars on each side of the MMX top plate, collect the spray solution from hoses for a period of 60 seconds, and measure the collected spray solution. Or insert the entire MMX inside a pan, and measure the spray solution collected over 60 seconds. Decrease or increase the pressure until you are collecting the desired flow for each MMX in 60 seconds. Check each MMX for proper flow rate.

Note: To calibrate accurately you must accurately determine the ground speed (mph), gallons per acre (gpa), and tank size.

Step 3 - Determine loaded ground speed (mph) under actual field conditions. If you are not sure your tractor has accurate ground speed indicator, use the following method to accurately determine ground speed:

- Use markers to determine the distance traveled in 30 seconds by starting the vehicle and adjusting the throttle to establish a constant speed, dropping an initial marker, and dropping another marker 30 seconds later.
- Measure the distance traveled in 30 seconds and use the following formula to determine the ground speed.

$$\text{mph} = \frac{\text{distance in feet}}{44}$$

Step 4 - To determine gallons per acre (gpa) refer to the Gallons per Acre chart on page 10. To compute figures if spacings not shown, use the following formula:

$$\text{gpa} = \frac{5940 \times \text{gpm flow rate of orifice}}{\text{mph} \times \text{spacing between MMXs}}$$

gpm will generally be the closest figure to 1 quart (25 gpm), 1 pint (125 gpm), 8 ounces (302 gpm) or 4 ounces (601 gpm)

spacing will be between 40 and 70 inches

Example: The equation below shows that a CP4916-37 orifice at 21 psi flow equals a gpm of 0.125, tractor speed is 5.5 mph, and the spacing between MMXs is 40 inches, resulting in a gpa equal to 3.38

$$\text{gpa} = \frac{5940 \times 0.125}{5.5 \times 40} = 3.38$$

Step 5 - To determine acres covered per load divide the tank size by the gallons per acre being applied.

Example: The equation below shows that using the gpa of 3.38, from step 4, and a tank size of 200 gallons equals 59.17 acres covered per load.

$$\frac{\text{acres/load} = 200}{3.38} = 59.17$$

Step 6 - To determine the amount of product to mix into the spray tank per load, multiply the acres covered per load, from step 5, by the pesticide manufacturer's recommended rate per acre.

Example: The equation below shows that to apply the recommended rate of 1 pint of Trellan™ per acre you should mix 59.17 pints or 7.4 gallons in the tank.

$$\begin{aligned} 59.17 \text{ acres/load} \times 1 \text{ pint/acre} &= 59.17 \text{ pints/load} \\ 59.17 \text{ pints/acre} &= 7.4 \text{ gallons/load} \\ &= 8 \text{ pints/gallon} \end{aligned}$$

### Determining Gallons per Acre of Total Spray Solution Applied

1. Flow Rate for 2,000 rpm Mode - In this mode, the correct flow rate will range between 1 pint and 1-1/2 quarts per minute. Refer to the Flow Rate of Orifice Plates graph and select the orifice plate which will deliver the desired flow rate.

Example: The Flow Rate of Orifice Plates graph shows that if a CP4916-37 orifice plate is selected and operated at 21 psi, the flow rate will be about 0.125 gpm. Figures are based on water as the spray solution, and correction can be made by increasing pressure.

2. Flow Rate for 3,500 rpm Mode - In this mode, the correct flow rate will range between 4 ounces and 1 pint per minute. Refer to the Flow Rate of Orifice Plates graph and select the orifice plate which will deliver the desired flow rate.

Example: The Flow Rate of Orifice Plates graph shows that if a CP4916-26 orifice plate is selected and operated at 19 psi, the flow rate will be about 0.061 gpm. Figures are based on water as the spray solution, and correction can be made by increasing pressure.

3. Flow Rate for 5,000 rpm Mode - In this mode, the correct flow rate will be as near to 4 ounces per minute as possible. Also, insecticides can be applied in an oil carrier at rates of 1 to 3 quarts per acre by using lower flow rates which can be calculated by the equation (Step 4) under the Calibration Section. Refer to Flow Rate of Orifice Plates graph and select the orifice plate which will deliver the desired flow rate. Operating with lower boom pressure will allow the use of larger orifice plates ensuring consistent flow of wettable powders.

Example: The Flow Rate of Orifice Plates graph shows that if a CP4916-20 orifice plate is selected and operated at 15 psi, the flow rate will be about 0.031 gpm. Figures are based on water as the spray solution, and correction can be made by increasing pressure.

Ground Speed ft/min	40 Inch Spinner Spacing			72 Inch Spinner Spacing		
	2000 RPM Flow Rate 1 qt/min	3500 RPM Flow Rate 1 qt/min	5000 RPM Flow Rate 1 qt/min	2000 RPM Flow Rate 1 qt/min	3500 RPM Flow Rate 1 qt/min	5000 RPM Flow Rate 1 qt/min
2.5	14.85	7.43	3.72	1.88	0.95	0.48
3.0	12.38	6.19	3.10	1.55	0.78	0.40
3.5	10.91	5.30	2.60	1.33	0.68	0.35
4.0	9.78	4.54	2.30	1.18	0.60	0.31
4.5	8.85	3.93	2.00	1.03	0.53	0.28
5.0	8.05	3.43	1.75	0.90	0.47	0.25
5.5	7.35	3.02	1.55	0.79	0.42	0.22
6.0	6.72	2.68	1.38	0.70	0.38	0.20
6.5	6.15	2.40	1.24	0.63	0.35	0.18
7.0	5.65	2.16	1.12	0.57	0.32	0.17
7.5	5.20	1.95	1.02	0.52	0.30	0.16
8.0	4.80	1.77	0.93	0.47	0.28	0.15
8.5	4.45	1.61	0.85	0.43	0.26	0.14
9.0	4.15	1.47	0.78	0.40	0.24	0.13
9.5	3.88	1.34	0.72	0.37	0.23	0.12
10.0	3.63	1.22	0.66	0.35	0.21	0.11
10.5	3.40	1.11	0.61	0.33	0.20	0.10
11.0	3.18	1.01	0.56	0.31	0.19	0.09
11.5	2.98	0.92	0.52	0.29	0.18	0.08
12.0	2.79	0.84	0.48	0.27	0.17	0.08

- A toggle switch may be used to switch the relay on and off. If a solenoid valve is used to shut off flow to the boom, the solenoid switch can be wired to switch the relay as well.
- Although mechanical wire splices can be used, it is better to attach each wire directly, solder each splice, and then wrap each with insulating tape for protection.

## IMPORTANT

For an MMX to operate properly and at the correct speed, it is very important that the electrical connections be tight and well protected to prevent voltage drop and current loss.

### Spray Application System

- Connect the main tube from the chemical tank to a supply tube, at least 3/4 inch in diameter, mounted on the spray boom.
- Insert 3/8 inch hose barb or slanks into the boom from the 3/4 inch supply tube for each MMX. Connect the 3/8 inch tube from each plumbing kit to the hose barb or slank.
- Connect the two 1/4 inch tubes from each plumbing kit to the two hose bars on the top plate of each MMX.

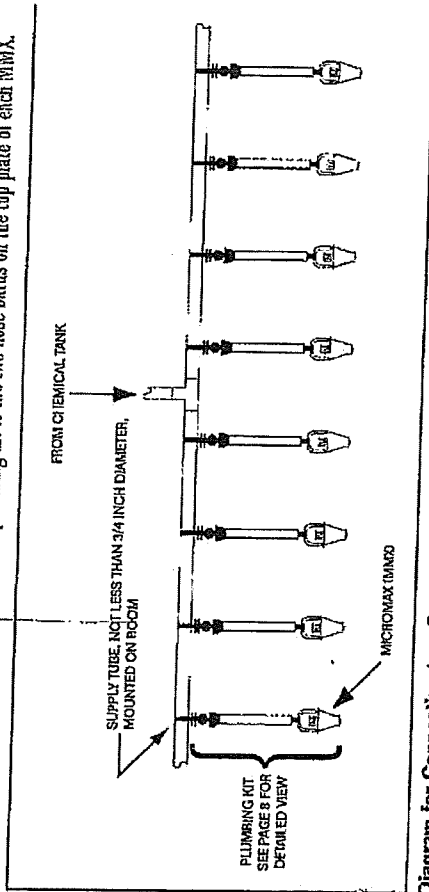

Diagram for Connecting to a Spray Boom

### Controlled Droplet Application

The MMX utilizes centrifugal force instead of hydraulic pressure to create spray patterns. This technology, referred to as controlled droplet application, produces the proper size droplet, determined by the chemical used and the target, to effectively apply a given concentration of pesticide uniformly over the target surface. Use of an MMX is a proven way to produce a uniform size droplet, while hydraulic nozzles emit droplet sizes that may vary significantly - from 1 micron to 500 microns or larger. This wide variation in droplet size causes inefficient application of the pesticide.

**Question:** What is a micron?

**Answer:** A micron is a unit of measurement equal to 0.00004 inches. 100 microns are approximately the thickness of a human hair, and there are 800 microns to 1/32 inch or 400 microns to 1/64 inch.

**Question:** Is adequate coverage possible when applying pre-plant incorporated or pre-emergent herbicides at volumes as low as 2.5 gallons per acre or less?

**Answer:** Yes. According to research data, the ideal size for applying pre-plant incorporated herbicides is 250 microns. The MMX, rotating at 2,000 rpm, produces a pattern that contains 90-95% droplets of 250 microns. Due to the inefficiency of the hydraulic nozzle, the maximum number of droplets emitted at this size is about 25% of the total, so large quantities of water are necessary to accomplish uniform coverage. Most pesticides can be applied as a concentrate, provided the droplets have sufficient mass to reach the target. An MMX can accomplish excellent distribution of the pesticide with a fraction of the water required by hydraulic nozzles.

**Question:** Will drift be a problem at low volumes?

**Answer:** At high wind velocities, drift is always a problem. However, according to drift test studies by the University of Saskatchewan at Saskatoon, it was determined that the initial drift from an 800Z spraying system nozzle at approximately 30 psi was 10 times greater than that from the MMX. Not only is drift less with an MMX than with a hydraulic nozzle, but with the uniform droplet size of a MMX, controlled drift is possible. Controlled drift is based on the fact that droplets of varying size drift different distances according to their mass. Studies by Alexson at the University of California at Davis indicate the following drift characteristics relative to droplet size in 3 mph wind when settling from 10 feet:

- 3 micron droplet drifts 8 miles
- 10 micron droplet drifts 1 mile
- 15 micron droplet drifts 2,000 feet
- 100 micron droplet drifts 30 feet
- 500 micron droplet drifts 5 feet

Controlled drift requires that all droplets be the same size to "drop out" the same distance from the point of emission. When spraying with the MMX at 5,000 rpm for insecticides and fungicide application, some wind movement is desirable. Air turbulence inside the blage of the crop is increased by the lateral motion of wind over the crop. The spray pattern, issuing from the rotating cone at over 1-million droplets per second, is not only drawn inside the crop canopy, but spun around within it to provide deposition on the bottom as well as top sides of the leaves and also on the stem.

In summary, for herbicide applications, MMX droplet sizes of 250 micron result in reduced drift. When smaller droplets are utilized for insecticide and fungicide sprays, the degree of swath displacement may increase but the drift off target is reduced compared to that of conventional hydraulic nozzles.

**Question:** Is it possible to reduce chemical dosage rates?

**Answer:** Chemical rates recommended for most pesticides are the result of hydraulic nozzle application field tests. While the MMX nozzle reduces waste caused by varying droplet size, additional research is required to determine lower dosage rates. The minimum recommended rate as indicated on the label must be followed. Recommendations are changed or until recognized agricultural authorities recommend lower rates.

The flow rate to each individual MMX should be constant. The amount of chemical solution applied per acre, is indicated in 0 gallons per acre chart. When operating the MMX at 2,000 rpm the flow rate to each unit should not exceed 1-2 1/2 quarts per minute. At 3,500 rpm the flow rate to each unit should not exceed 1 pint per minute. And at 5,000 rpm, the flow rate to each should not exceed 5 ounces per minute. The control of the flow rate is determined by boom pressure and orifice plate size. In for the check valves to function properly it is best to operate boom pressure in the range of 15 to 20 psi. Higher pressures are utilized for flow control, however, a larger orifice plate will ensure a consistent flow when variable pressures are applied. Orifice plates are inserted into the spray line at the plumbing kit after the diaphragm check valve and strainer, and before the tee that divides the chemical solution into each side of the MMX. Orifice plates (P1916-55 and P1916-37 are included with each MMX, however, other orifice plates may be ordered and used to achieve a desired flow rate.

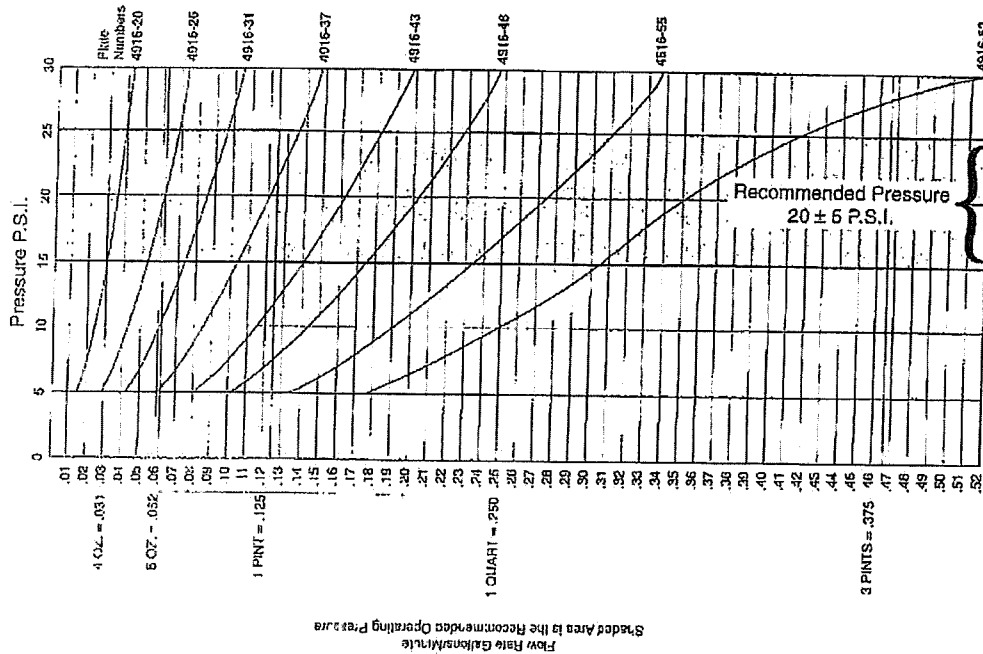

Graph for Determining the Flow Rate of Different Orifice Plates 4916-83

## Plumbing Kit Assembly (Part Number MMX/202)

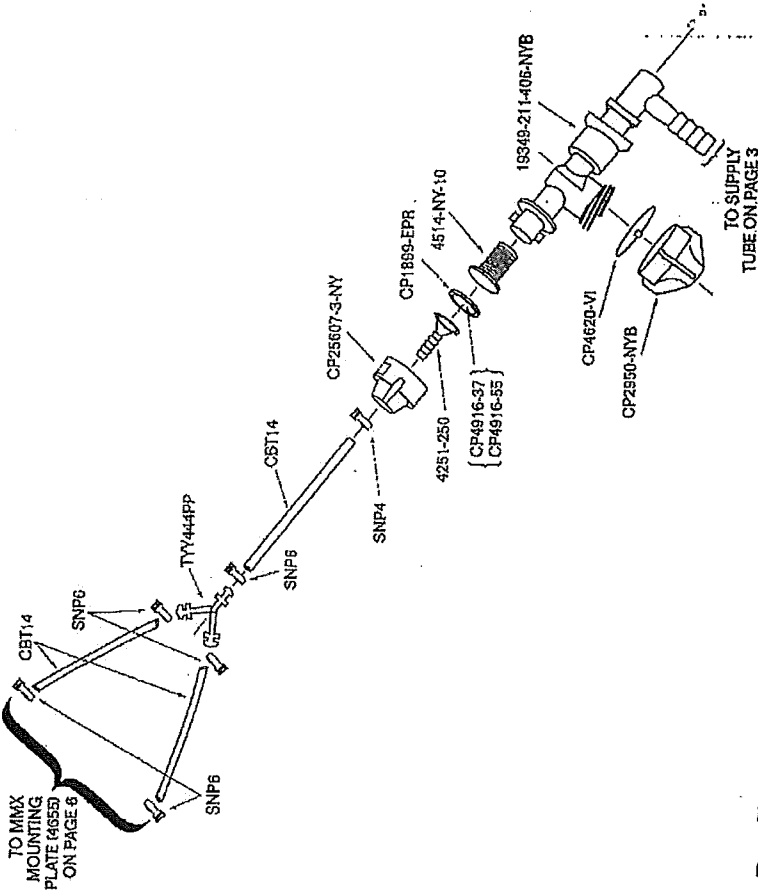

Part Number	Quantity	Description
CBT14	3	1/4" x 8" Clear Braided Tubing
CP1899-EPR	1	Seal, EPDM Rubber
CP25607-3-NY	1	Quick Tejet Cap, Nylon, Red
CP2550-NYB	1	End Cap
CP4620-VI	1	Diaphragm, Viton
CP4916-37	1	Orifice Plate No. 37
CP4916-55	1	Orifice Plate No. 55
SNP4	1	Snapper Hose Clamp
SNP6	5	Snapper Hose Clamp
TTY444PP	1	1/4" Nylon Y
19349-211-406-NYB	1	Diaphragm Check Valve, Nylon (includes CP2550-NYB and CP4620-VI)
4251-250	1	Tejet Hose Shank, Brass
4514-NY-10	1	Tejet Slot Strainer, Nylon

## MMX Spacing

In selecting the proper spacing for mounting MMX units the following operation parameters should be kept in mind:

1. Ideal spacing between MMX units is 40 inches for all speeds, and is recommended for 3,500 and 5,000 rpm to provide a consistent spray pattern across the spray boom.
2. Operating at 2,000 rpm with a 1 quart flow rate, the MMX has a 4% spray pattern coefficient of variation, much less than with hydraulic nozzles. Therefore, at 2,000 rpm, wider spacing is possible. Overlap of pattern can be expected up to 70 inches under ideal spraying conditions. However, the spray pattern coefficient of variation will increase, and it is best to keep the percent variation at a minimum.

## Micromax Applicator Speeds

Total spray volume must be sufficient to ensure an adequate coverage of the target area, and adequate coverage is directly related to droplet size. Refer to Table 1 for droplet size per flow rate and Table 2 to estimate droplets per square inch of target area and potential coverage.

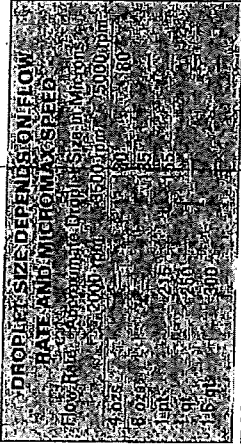

Table 1

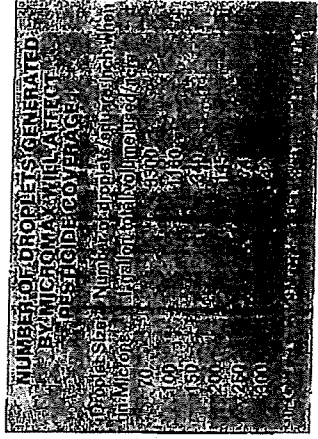
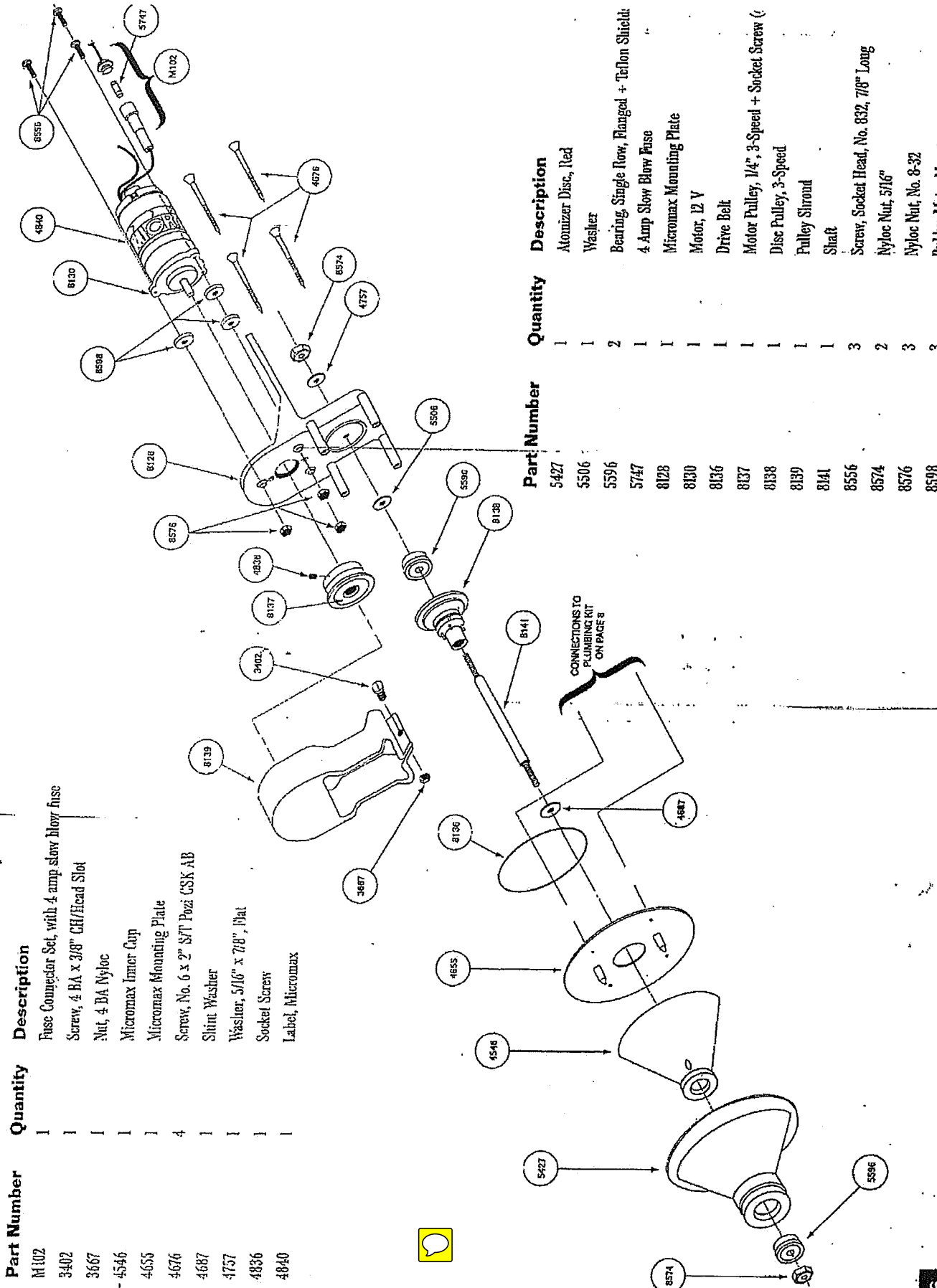

Table 2

1. Low Speed (2,000 rpm) — This speed will deliver a droplet size in the range of 200 to 300 microns, depending on the flow rate used, and it is suggested for use with herbicides, foliar fertilizers and soil insecticides. Using the MMX at the 2,000 rpm, low speed will minimize spray drift, and thereby reduce potential damage to surrounding crops.
2. Medium Speed (3,500 rpm) — This speed will deliver a droplet size in the range of 130 to 150 microns, depending on the flow rate used, and it is suggested for use with post-emergent herbicides, defoliants, and desiccants.
3. High Speed (5,000 rpm) — This speed will deliver droplets of nearly 80 microns in size at a flow rate of 4 ounces per minute. The high speed is suggested for use with insecticides and fungicides where lateral movement is beneficial to achieve droplet penetration. This will also improve droplet impingement on both horizontal and vertical target areas.



Part Number	Quantity	Description
M102	1	Fuse Connector Set, with 4 amp slow blow fuse
3402	1	Screw, 4 BA x 3/8" CH/Head Slot
3667	1	Nut, 4 BA Nylon
4546	1	Micromax Inner Cup
4655	1	Micromax Mounting Plate
4676	4	Screw, No. 6 x 2" S/T Pozid CSK AB
4687	1	Slit Washer
4757	1	Washer, 5/16" x 7/8", Flat
4836	1	Socket Screw
4840	1	Label, Micromax

Part Number	Quantity	Description
5427	1	Atomizer Disc, Red
5506	1	Washer
5596	2	Bearing, Single Row, Flanged + Teflon Slitcld.
5747	1	4 Amp Slow Blow Fuse
8128	1	Micromax Mounting Plate
8130	1	Motor, 12 V
8136	1	Drive Belt
8137	1	Motor Pulley, 1/4", 3-Speed + Socket Screw (
8138	1	Disc Pulley, 3-Speed
8139	1	Pulley Shroud
8141	1	Shaft
8556	3	Screw, Socket Head, No. 832, 7/8" Long
8574	2	Nyloc Nut, 5/16"
8576	3	Nyloc Nut, No. 8-32
8598	3	Rubber Motor Mounts

CONNECTIONS TO PLUMBING KIT ON PAGE 8



# Micromax Controlled Droplet Applicator Assembly

Part Number	Quantity	Description
3402	1	Screw, 4 BA x 3/8" CH/Head Slot
3667	1	Nut, 4 BA Nylon
4676	4	Screw, No. 6 x 2" ST Pozz CSK AB
4687	1	Shim Washer
4757	1	Washer, 5/16" x 7/8", Flat
4836	1	Socket Screw
4840	1	Label, Micromax
5880	1	Micromax Inner Cup
6033	1	Micromax Mounting Plate
6034A	1	Fuse Connector Set, with 4 amp slow blow fuse

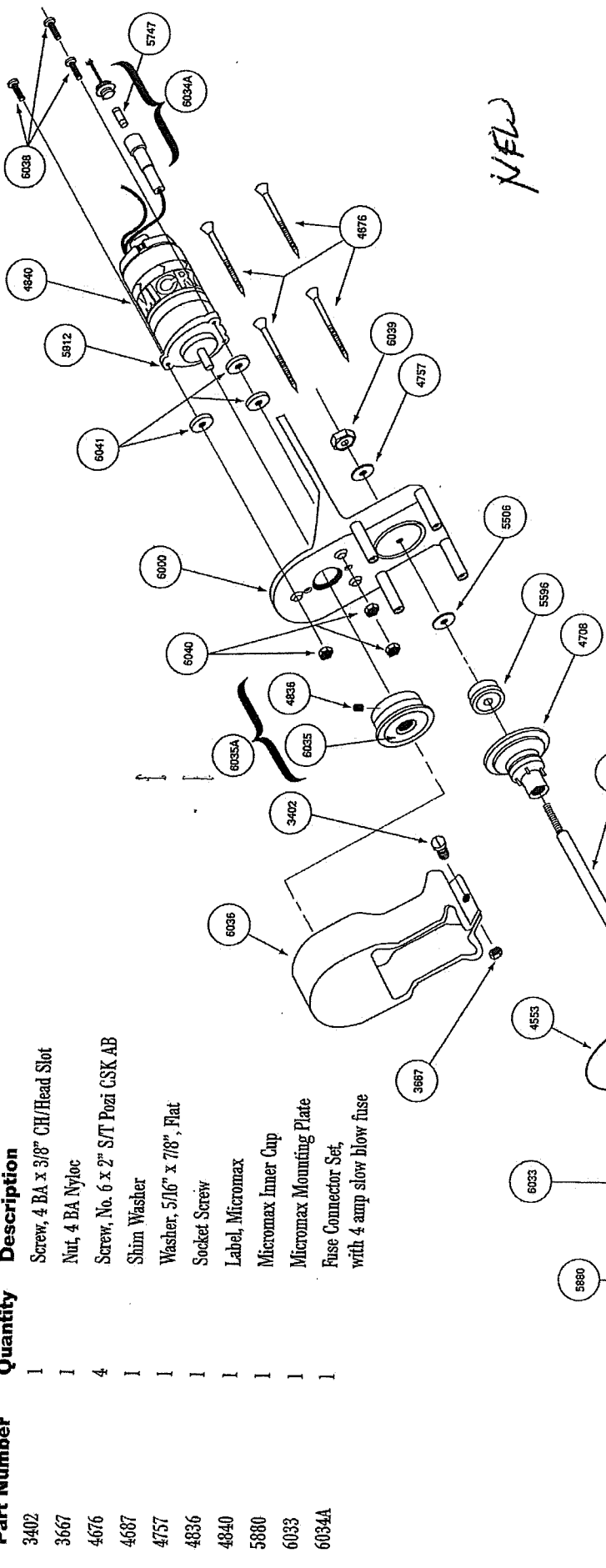

Part Number	Quantity	Description
4553	1	Drive Belt
4708	1	Disc Pulley, 3-Speed
5427	1	Atomizer Disc, Red
5506	1	Washer
5596	2	Bearing, Single Row, Flanged + Teflon Shields
5747	1	4 Amp Slow Blow Fuse
5912	1	Motor, 12 V
6000	1	Micromax Mounting Plate
6035A	1	Motor Pulley, 1/4", 3-Speed + Socket Screw (4836)
6036	1	Pulley Shroud
6037	1	Shaft
6038	3	Screw, Socket Head, No. 832, 7/8" Long
6039	2	Nyloc Nut, 5/16"
6040	3	Nyloc Nut, No. 8-32
6041	3	Rubber Motor Mounts