



170 W 600 N
Shelbyville, Indiana 46176
(317) 398-4636 or
(317) 398-7973
FAX (317) 398-2107

Limited Warranty

Kasco Mfg. Co., Inc., hereinafter referred to as "Kasco" warrants all its products against defects in materials and workmanship for one year after date of purchase, except those component parts not manufactured by "Kasco" which parts are warranted by "Kasco" only to the extent of the original manufacturers warranty.

Should any part manufactured by "Kasco" prove defective within one year from date of purchase, supposed defective part shall be returned freight paid to our "Kasco" factory for "Kasco's" consideration. If found to be defective by "Kasco", credit will be issued through proper channels, distributor and/or dealer.

"Kasco" will not assume liability for any labor costs, loss or damage caused by a defective part, consequential damages, or operational delays.

Altering or misuse of a part will void the "Kasco Warranty". Repairing of a part without the expressed permission of "Kasco" voids the "Kasco Warranty".

"Kasco" neither assumes nor authorizes any person to assume for "Kasco" any other obligations or liability in connection with the sale of its equipment.

"Kasco" reserves the right to make improvements in design or changes in specifications at any time without incurring any obligations to owners of equipment previously sold.

Definitions of Terms

- 1) – Hazard – A source of potential injury to a person.
- 2) - Safety Sign – A visual alerting device in the form of a decal, label, placard, or other marking such as embossing, stamping, etching, or other processes that advised the observer of the nature and degree of the potential hazard(s) that can cause injury or death. It can also provide safety precautions or evasive actions to take, or provide other directions to eliminate or reduce the hazard.
- 3) – Signal Word – The word that designates a degree or level of hazard seriousness. The signal words are DANGER, WARNING, and CAUTION.
- 4) – Danger – Indicates an imminently hazardous situation that if not avoided, will result in serious injury. This signal word is to be limited to the most extreme situations, typically for machine components that, for functional purposes, cannot be guarded.
- 5) – Warning – Indicates a potentially hazardous situation that, if not avoided, will result in serious injury, and includes hazards that are exposed when guards are removed. It may also be used to alert against unsafe practices.

Tractor Safety:

1. Securely fasten your seat belt if the tractor has a roll over protection system (ROPS).
2. Where possible, avoid operating the tractor near ditches, embankments, and holes.
3. Reduce speed when turning, crossing slopes, on rough, slick, or muddy surfaces.
4. Stay off slopes too steep for safe operation.
5. Watch where you are going, especially at row ends, on roads, and around trees.
6. Do not permit others to ride.
7. Operate the tractor smoothly - no jerky turns, starts, or stops.
8. Hitch only to the drawbar and hitch points recommended by tractor manufacturers.
9. When tractor is stopped, set brakes securely and use parking brake if available.

Equipment Safety:

1. Keep all guards in place.
2. Permit no riders on farm field equipment other than persons required for instruction or assistance in machine operation.
3. Stop engine, disconnect power source, and wait for all machine movement to stop before servicing, adjusting, cleaning, or unclogging the equipment, except where the machine must be running to be properly serviced or maintained. In which case the employer shall instruct employees as to all steps and procedures

which are necessary to safely service or maintain the equipment.

4. Make sure everyone is clear of machinery before starting the engine, engaging power, or operating the machine.

5. Lockout electrical power before performing maintenance or service on farmstead equipment.

Before Operation:

- Carefully study and understand this manual.
- Do not wear loose-fitting clothing which may catch moving parts.
- Always wear protective clothing and substantial shoes.
- It is recommended that suitable protective hearing and (eye protection) sight protectors be worn.
- The operator may come in contact with certain materials which may require specific safety equipment, relative to the handling of such materials (examples: extremely dusty, molds, fungus, bulk fertilizers, etc.)
- Keep wheel lug nuts or bolts tightened to specific torque.
- Assure that agricultural implement tires are inflated evenly.
- Give the unit a visual inspection for any loose bolts, worn parts or cracked welds, and make any necessary repairs. Follow the maintenance safety instructions included in this manual.
- Be sure that there are no tools lying on or in the equipment.
- Do not use the unit until you are sure that the area is clear, especially children and animals.
- Because it is possible that this equipment may be used in dry areas or in the presence of combustibles, special precautions should be taken to prevent fires and fire fighting equipment should be readily available.

- Don't hurry the learning process or take the unit for granted. Ease into it and become familiar with your new equipment.
- Practice operation of your equipment and its attachments. Completely familiarize yourself and other operators before using.
- Move tractor wheels to the widest recommended settings to increase stability.
- Securely attach to towing unit. Use a high strength, appropriately sized hitch pin with a mechanical retainer and attach a safety chain.
- Do not allow anyone to stand between the tongue or hitch and the towing vehicle when backing up the equipment.

During Operation:

- SAFETY CHAIN - If equipment is going to be transported on a public highway, a safety chain should be obtained and installed. Always follow state and local regulations regarding a safety chain and auxiliary lighting when towing farm equipment on a public highway. Be sure to check with local law enforcement agencies for your own particular regulations. Only a safety chain (not an elastic or nylon/plastic tow strap) should be used to retain the connection between the towing and towed machines in the event of separation of the primary attaching system.
- Install the safety chain by crossing the chains under the tongue and secure to the draw bar cage or hitch or bumper frame.
- Beware of bystanders, particularly children! Always look around to make sure that it is safe to start the engine of the towing vehicle or move the unit. This is particularly important with higher noise levels and quiet cabs, as you may not hear people shouting.
- NO PASSENGERS ALLOWED - Do not carry passengers anywhere on, or in, the tractor or equipment, except as required for operation.
- Keep hands and clothing clear of moving parts.
- Do not clean, lubricate or adjust your equipment while it is moving.

- When halting operation, even periodically, set the tractor or towing vehicle brakes, disengage the PTO, shut off the engine and remove the ignition key.
- Be especially observant of the operating area and terrain - watch for holes, rocks or other hidden hazards. Always inspect the area prior to operation.]
 - DO NOT operate near the edge of drop offs or banks.
 - DO NOT operate on steep slopes as overturn may result.
 - Operate up and down (not across) intermediate slopes. Avoid sudden starts and stops.
- Pick the levellest possible route when transporting across fields. Avoid the edges of ditches or gullies and steep hillsides.
- Be extra careful when working on inclines.
- Periodically clear the equipment of brush, twigs or other materials to prevent buildup of dry combustible materials.
- Maneuver the tractor or towing vehicle at safe speeds.
- Avoid overhead wires or other obstacles. Contact with overhead lines could cause serious injury or death.
- Avoid loose fill, rocks and holes; they can be dangerous for equipment operation or movement.
- Allow for unit length when making turns.
- Do not walk or work under raised components or attachments unless securely positioned or blocked.
- Keep all bystanders, pets and livestock clear of work area.
- Operate the towing vehicle from operators seat only.
- Never stand alongside of unit with engine running or attempt to start engine and/or operate machine while standing alongside of unit.

- Never leave running equipment attachments unattended.
- As a precaution, always recheck the hardware of equipment following every 20 hours of operation. Correct all problems. Follow the maintenance safety procedures.

Following Operation:

- Following operation, or when unhitching, stop the tractor or towing vehicle, set the brakes, disengage the PTO and all power drives, shut off the engine and remove the ignition keys.
- Store the unit away from human activity.
- Do not park equipment where it will be exposed to livestock for long periods of time. Damage and livestock injury could result.
- Do not permit children to play on or around the stored unit.
- Make sure all parked machines are on a hard, level surface and engage all safety devices.
- Wheel chocks may be needed to prevent unit from rolling.

Highway and Transport Operations:

- Adopt safe driving practices:
 - Keep the brake pedals latched together at all times. NEVER USE INDEPENDENT BRAKING WITH A MACHINE IN TOW AS LOSS OF CONTROL AND/OR UPSET OF UNIT CAN RESULT.
 - Always drive at a safe speed relative to local conditions and ensure that your speed is low enough for an emergency stop to be safe and secure. Keep speed to a minimum.

- Reduce speed prior to turns to avoid the risk of overturning.
- Avoid sudden uphill turns on steep slopes.
- Always keep the tractor or towing vehicle in gear to provide engine braking when going downhill. Do not coast.
- Do not drink and drive!
- Comply with state and local laws governing highway safety and movement of farm machinery on public roads.
- Use approved accessory lighting flags and necessary warning devices to protect operators of other vehicles on the highway during daylight and nighttime transport. Various safety light and devices are available from your dealer.
- The use of flashing amber light is acceptable in most localities. However, some localities prohibit their use. Local laws should be checked for all highway lighting and marking requirements.
- When driving a tractor and equipment on the road or highway under 40kph (20 mph) at night or during the day, use flashing amber warning lights and a slow moving vehicle (SMV) identification emblem.
- Plan your route to avoid heavy traffic.
- Be a safe and courteous driver. Always yield to oncoming traffic in all situations, including narrow bridges, intersections, etc...
- Be observant of bridge loading ratings. Do not cross bridges rated lower than the gross weight at which you are operating.
- Watch for obstructions overhead and to the side while transporting.
- Always operate equipment in a position to provide maximum visibility at all times. Make allowances for increased length and weight of the equipment when making turns, stopping the unit, etc...

Performing Maintenance:

- Good maintenance is your responsibility. Poor maintenance is an invitation to trouble.
- Make sure there is plenty of ventilation. Never operate the engine of the towing vehicle in a closed building. The exhaust fumes may cause asphyxiation.
- Before working on this machine, stop the towing vehicle, set the brakes, disengage the PTO and all power drives, shut off the engine and remove the ignition keys.
- Be certain all moving parts on attachments have come to a complete stop before attempting to perform maintenance.
- ALWAYS use a safety support and block the wheels. Never use a jack to support the machine.
- Always use the proper tools or equipment for the job at hand.
- Use extreme caution when making adjustments.
- Never use your hands to locate a hydraulic leak on attachments. Use a small piece of cardboard or wood. Hydraulic fluid escaping under pressure can penetrate the skin.
- When disconnecting hydraulic lines, shut off hydraulic supply and relieve all hydraulic pressure.
- Openings in the skin and minor cuts are susceptible to infection from hydraulic fluid. If injured by escaping hydraulic fluid, see a doctor at once. Gangrene can result. Without immediate medical treatment, serious infection and reactions can occur.
- Replace all shields and guards after servicing and before moving.
- After servicing, be sure all tools, parts and service equipment are removed.

-
- Do not allow grease or oil to build up on any step or platform.
 - Never replace hex bolts with less than grade 5 bolts unless otherwise specified.
 - Where replacement parts are necessary for periodic maintenance and servicing, genuine factory replacement parts must be used to restore your equipment to original specifications. The manufacturer will not claim responsibility for use of unapproved parts and/or accessories and other damages as a result of their use.
 - If equipment has been altered in any way from original design, the manufacturer does not accept any liability for injury or warranty.
 - A fire extinguisher and first aid kit should be kept readily accessible while performing maintenance on this equipment.

CHANGING SEED

When changing seed sizes, particularly going from large seed to smaller, the seed hopper should be completely cleaned out.

1. Open the seed metering system to largest amount.
2. Remove upper chain shield by pulling two hairpin clips.
3. Pull up idler and remove chain from smaller sprocket.
4. Remove hopper pivot locking pin.
5. Tilt seed hopper back. Remove all unwanted seed.
6. ***REPLACE ALL SHIELDING AND LOCKING PINS BEFORE USE!***

MAINTAINENCE

- ◆ Check chain daily.
- ◆ Lubricate bearings after every 20 hours of use.
- ◆ Grease zerks on slicer bar every day.
- ◆ Tighten bolts daily.

SAFETY DECALS



SW 403

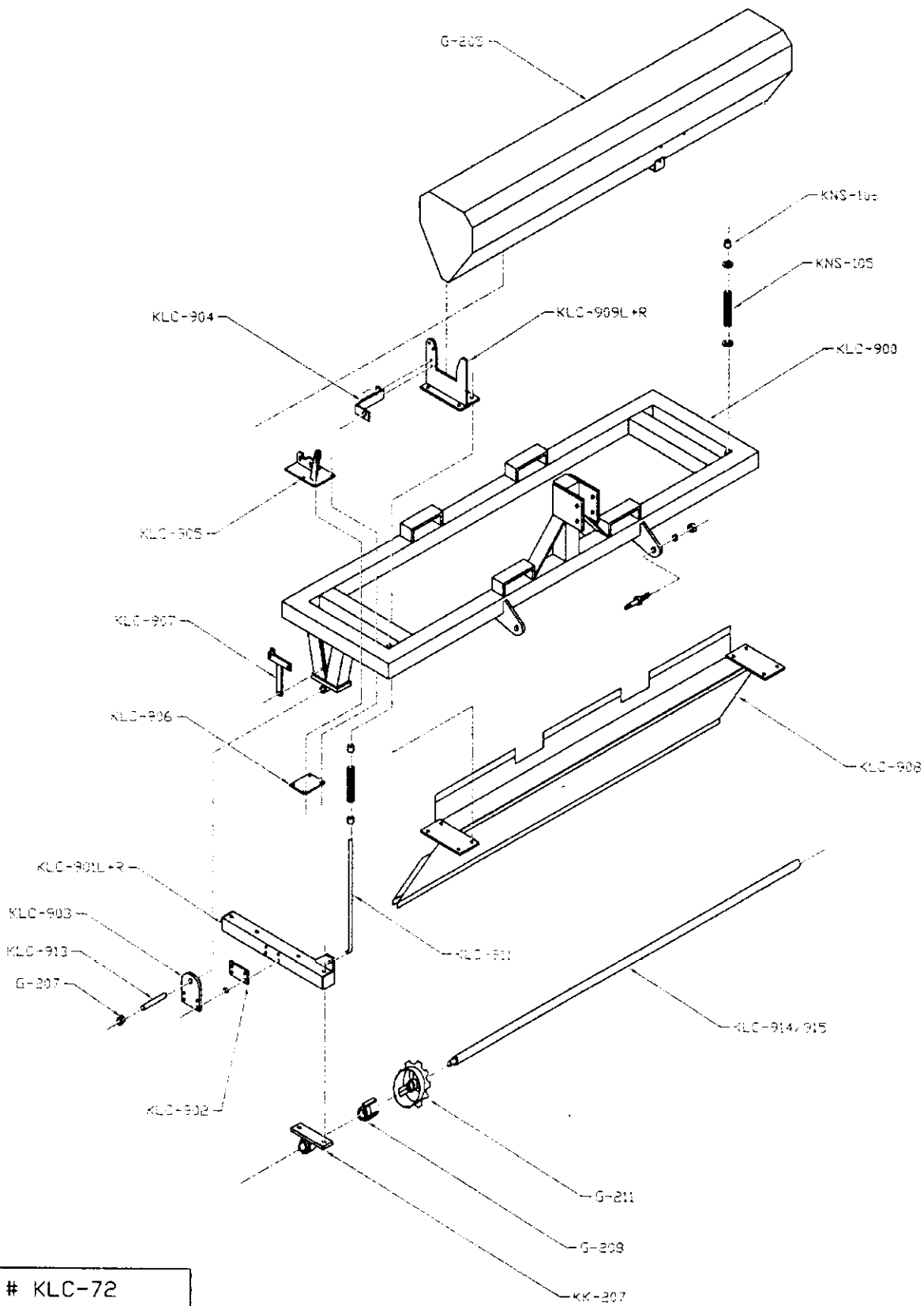

Model # KLC-72

Do 10/06/04

KASCO MFG. CO. INC.
SHELBYVILLE, INDIANA

Rev.# 1

User: JH

PART #	DESCRIPTION	QUANTITY
KLC-900	Main Frame	1
KLC-901L	Cultipacker Walking Arm	1
KLC-901R	Cultipacker Walking Arm	1
KLC-902	Pivot Bar Plate	4
KLC-903	Pivot Bar Spacer	4
KLC-904	Hopper Gear Retainer	1
KLC-905	Idler/Bearing Brkt.	1
KLC-906	Idler/Bearing Plate	1
KLC-907	Idler Arm	1
KLC-908	72" Shoot	1
KLC-909L	Shoot Mtg. Brkt.	1
KLC-909R	Shoot Mtg. Brkt.	1
KLC-910	Idler Spacer	1
KLC-911	23 1/2" Spring Rods	2
KLC-912	Rear Cult. Shaft Spacer. (1 3/16" I.D.x2 1/4" O.D.x2 3/16")	2
KLC-913	Pivot Bar (5 3/4"x1") Cold Roll	2
KLC-914	Cultipacker Shaft Rear (83 1/2"x1 3/4")	1
KLC-915	Cultipacker Shaft Front (86 1/2"x1 3/4")	1
KLC-916	Main Chain Guard	1
KLC-917	Sec. Chain Guard	1
KK-207	1 3/4" Bearings	4
G-205	72" Hopper	1
G-207	1" Locking Collar	4
G-208	Locking Collar Weldmt.	2
G-211	Cultipacker Wheel	67
KNS-105	Spring	4
KNS-106	Locking Collar	4
KED-902	Hex shaft	1
KED-913	Crustbuster metering system	9
KED-914	Handle assm - seed box	1
KED-915	Handle lock brace	1
KED-916	Handle brace	2
KED-917	Collar weldment - handle	1
SL-085	Roller	3

To Adjust Seed Metering System

Handle

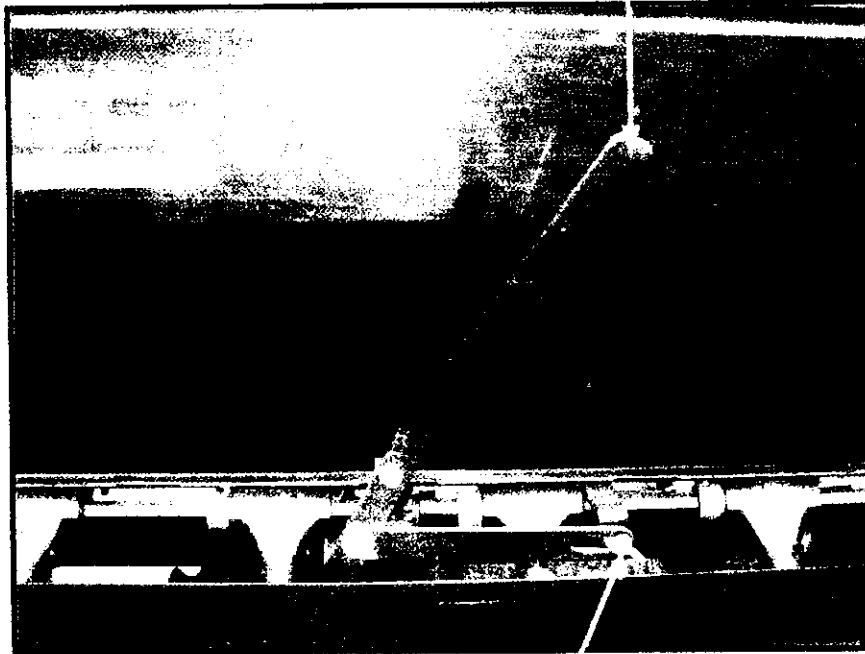

Wing Nut

- 1) Loosen Wing nut.
- 2) Slide the handle until the measurement gauge is in line with the proper measurement, in accordance to the seed calibration chart.

REMEMBER:

Speed of the transmission + proper opening of the metering system = proper seeding rate.