

**Important!**

**Do Not Destroy!**

**Please Read!**

***Herd***

**SURE - FEED  
BROADCASTER**

***Herd***

**MODEL 2440**

**CAPACITY:**

**2,440 LBS., 40 CU. FT., 32 BU.**

(Cylinder Not Furnished.)

Use ASAE Standard 8 inch stroke with 28.38 inch extended length  
between pin centerlines.

***Instructions for  
Assembly, Mounting, Seeding,  
Operating and Maintenance.***

(Shown with Optional Lid)  
Part #1136

***Repair  
Parts List***



[www.herdseeder.com](http://www.herdseeder.com)  
[info@herdseeder.com](mailto:info@herdseeder.com)

**HERD SEEDER COMPANY, INC.**

**PHONE NO: 219-753-6311**

**NOTE! New Area Code as of January 2002 is: 574**

P.O. BOX 448  
2383 SOUTH U.S. 35  
LOGANSPOUT, INDIANA 46947-0448

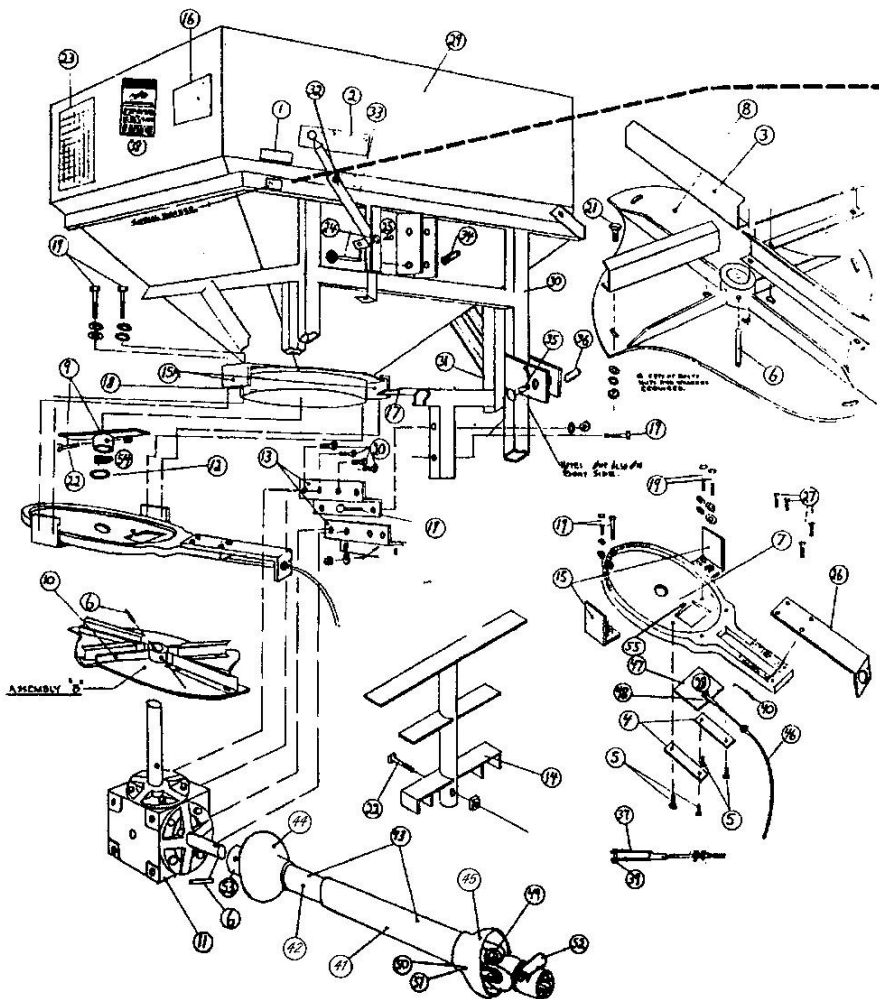

SERIAL NUMBER LOCATED ON WELDED PLATE, JUST BELOW MODEL NO. DECAL

# Herd

MODEL 2440  
BROADCASTER

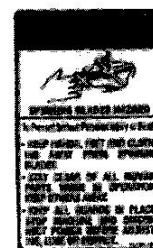

Warning Decal - If missing Call 219/753-6311 for free replacement.

**CAUTION:** KEEP all guards and shields in place at all times. Disengage power take-off and shut off tractor engine before making any adjustments or repairs to seeder. KEEP hands, fingers and loose clothing well away from any and all moving parts at all times.

**PARTS FOR MODEL 2440 BROADCAST SPREADER SHOWN IN PHOTO:**

WHEN ORDERING PARTS, BE SURE TO GIVE BOTH MODEL NUMBER AND SERIAL NUMBER. SEE ABOVE LOCATION FOR SERIAL NUMBER.

NUMBER	PART NO.		NUMBER REQUIRED
1.	99	DECAL - MODEL NO. 2440 .....	1
2.	100	DECAL FOR HYDRAULIC OPENING CHART .....	1
3.	102	FAN BLADE W/BOLT .....	4
4.	106	SEED GATE, OR CONTROL PLATE, SLIDE OR GUIDE .....	2
5.	107	1/4 X 1/2" HEXHEAD CAPSCREW .....	4
6.	111	5/16 X 2" SPRING PIN FOR DRIVEN END OF POWER TAKE-OFF SHAFT AND FAN .....	2
7.	144	BASE PLATE, ALUMINUM CIRCULAR, AT BOTTOM OF HOPPER .....	1
8.	145	FAN BASE - 1" BORE .....	1
9.	147	REGULAR AGITATOR COMPLETE W/BOLT & NUT, FOR 1" SHAFT .....	1
10.	148	FAN, COMPLETE W/SPRING PIN - 1" BORE (ASSEMBLY "B") .....	1
11.	2000	GEARBOX, COMPLETE FOR TRACTORS WITH 540 RPM (SAME AS 151) .....	1
12.	152	1" BORE STEEL SPACE WASHER - USED IN HOPPER ON FAN SHAFT .....	1
13.	154	"Z" ANGLES USED TO CARRY GEAR BOX - LEFT SIDE .....	2
	153	"Z" ANGLES USED TO CARRY GEAR BOX - RIGHT SIDE (NOT SHOWN) .....	2
14.	158	LIME AGITATOR W/BOLT - FOR USE IN SPREADING DOLOMITE AND DEHYDRATED LIME (OPTIONAL) .....	1

15.	159	"L" BASE CLAMP - LOWER .....	2
15A.	160	"L" BASE CLAMP - UPPER, FOR HOLDING CIRCULAR BASE PLATE TO HOPPER .....	2
16.	163	FERTILIZER INSTRUCTION DECAL .....	1
17.	207	DEFLECTOR - 24" LONG .....	1
18.	223	HOPPER BASE RING (MUST BE WELDED TO HOPPER) .....	1
19.	418	1/2 X 3" MACHINE BOLT W/NUT & WASHER .....	8
20.	419	3/8 X 1" MACHINE BOLT - HARDENED .....	8
21.	420	5/16 X 3/4" CARRIAGE BOLT W/NUT & LOCKWASHER .....	8
22.	422	5/16 X 1-3/4" MACHINE BOLT W/NUT - USED IN REGULAR AGITATOR & LIME AGITATOR.....	1
23.	989C	SEEDING CHART DECAL .....	1
24.	1003	1" PIN - PINS OPENING CONTROL ARM TO BRACKET .....	1
25.	1004	3" HAIRPIN COTTER - FOR 1003 1" PIN .....	1
26.	1007	BRACKET - USED TO FASTEN CABLE TO BASE PLATE .....	1
27.	1008	1/4 X 3/4" HEXHEAD CAPSCREW .....	4
28.	1010	OPENING PLATE WITH CLEVIS, 5/16 X 3/4 SPRING PIN AND 5/16" DRILLED NUT SPACER	1
29.	1011	HOPPER FOR 2440 .....	1
30.	1012	BASE FRAME FOR 2440 (SOLD AS UNIT ONLY) .....	1
31.	1013	GEAR CASE CARRYING FRAME FOR 2440 (SOLD AS UNIT ONLY).....	1
32.	1014	OPENING CONTROL ARM ASSEMBLY WITH 1-1/4" X 3/16" POINTER & OPENING BRACKET ATTACHED .....	1
33.	1015	1" X 6" PIN.....	1
34.	1016	BUSHING FOR 1015 PIN (1" I.D. X 1-1/4" O.D.) .....	1
35.	1017	1-1/8" X 6" PIN .....	2
36.	1018	BUSHING FOR 1017 PIN (1-1/8" I.D. X 1-3/8" O.D.).....	2
37.	1112	CLEVIS, COMPLETE WITH PIN & CLEVIS PIN .....	1
38.	1091	WARNING DECAL .....	1
39.	1115	HAIRPIN COTTER (1-1/4" - USED ON PIVOT TERMINAL CLEVIS PIN .....	4
40.	1124	PULL SPRING - FOR 48" CABLE.....	1
41.	1131P	SHIELD ONLY FOR TRACTOR END OF POWER TAKE-OFF SHAFT (SPECIFY MAKE OF P.T.O.) ...	1
42.	1132P	SHIELD ONLY FOR SEEDER END OF POWER TAKE-OFF SHAFT (SPECIFY MAKE OF P.T.O.).....	1
43.	1133P	COMPLETE POWER TAKE-OFF SHAFT WITH Q.T. YOKE 1-3/8" SPLINE. 33" OVERALL LENGTH. FOR 540 R.P.M. POWER TAKE-OFF SHAFT TRACTORS .....	1
44.	1133FP	SEEDER END ONLY, OF POWER TAKE-OFF SHAFT.....	1
45.	1133MP	TRACTOR END ONLY, OF POWER TAKE-OFF SHAFT .....	1
46.	1148	48" PUSH-PULL CABLE FOR REMOTE CONTROL (*) .....	1
47.	1024	OPENING PLATE ONLY FOR HYDRAULIC CONTROL .....	1
48.	1025	CLEVIS, SPRING PIN AND SPACER ONLY .....	1
49.	78	UNIVERSAL JOINT REPAIR KIT FOR WEASLER POWER TAKE-OFF SHAFT.....	2
	843	CROSS & BEARING REPAIR KIT FOR G & G POWER TAKE-OFF SHAFT. ....	2
50.	79P	NYLON BEARING FOR PLASTIC SHIELD OF WEASLER POWER TAKE-OFF SHAFT .....	2
	46	NYLON BEARING FOR PLASTIC SHIELD OF G & G POWER TAKE-OFF SHAFT .....	2
51.	80P	BEARING RETAINER FOR PLASTIC SHIELD OF WEASLER POWER TAKE-OFF SHAFT .....	2
	47	BEARING RETAINER FOR PLASTIC SHIELD OF G & G POWER TAKE-OFF SHAFT .....	2
52.	96	YOKE ONLY, FOR TRACTOR HALF OF WEASLER POWER TAKE-OFF SHAFT. ....	1
	101	YOKE ONLY, FOR TRACTOR HALF OF G & G POWER TAKE-OFF SHAFT. ....	2
53.	97	YOKE ONLY, FOR SEEDER HALF OF WEASLER POWER TAKE-OFF SHAFT. ....	1
	103	YOKE ONLY, FOR SEEDER HALF OF G & G POWER TAKE-OFF SHAFT. ....	1
54.	1123	STAINLESS STEEL COMPRESSION SPRING-USED BETWEEN AGITATOR AND WASHER ...	1
55.	1126	1/4" X 3/8" HEXHEAD CAPSCREW.....	1
	206	LARGE "HERD SURE-FEED BROADCASTER" DECAL (NOT SHOWN) .....	1
	273	COMPLETE SET OF DECALS FOR MODEL 2440 SEEDER.....	1

(\* WARRANTED AGAINST DEFECTS ONLY)

(Cylinder Not Furnished)

Use ASAE Standard 8 inch stroke with 28.38  
inch extended length between pin centerlines.

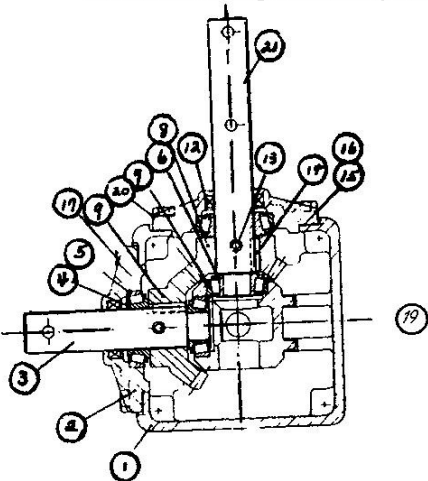

**PARTS FOR 2000 (OR 151 GEARBOX WITH 1" SHAFTS:  
FOR MODEL 2440**

1.	2017	HOUSING .....	1
2.	2016	CAP .....	2
3.	2018	SHORT SHAFT, DRIVE .....	1
4.	2013	BEARING CONE - LARGE (L44643) .....	2
5.	2012	BEARING CUP - LARGE (44610) .....	2
6.	2011	BEARING CONE - SMALL (LM11749) .....	2
7.	2010	BEARING CUP - SMALL (LM11710) .....	2
8.	2014	GEAR, STEEL, 14-TOOTH .....	1
9.	2019	GEAR, STEEL, 19-TOOTH .....	1
12.	2009	OIL SEAL .....	2
13.	2005	ROLL PIN .....	2
14.	2008	KEY .....	2
15.	2006	GASKET - .015 .....	VAR.
16.	2007	GASKET - .005 .....	VAR.
17.	2002	5/16" x 1" HEXHEAD CAPSCREW .....	8
19.	2003	VENTED PIPE PLUG .....	1
20.	2001	5/16" LOCKWASHER .....	8
21.	2015	LONG SHAFT - VERTICAL DRIVEN.....	1
	2020	SHIM.....	VAR

## **OPTIONAL ACCESSORIES:**

158	LIME AGITATOR FOR SPREADING DOLOMITE OR DEHYDRATED LIME (SEE NO. 14 ON PAGE 1) .....	1
1136	COMPLETE LID (2 PCS.) FOR 2440 .....	1
1134	LEFT SIDE ONLY OF LID FOR 2440 .....	1
1135	RIGHT SIDE ONLY OF LID FOR 2440, WITH HANDLE .....	1
268	REGULAR TRAILER WITH 45" P.T.O. SHAFT; 15" WHEELS, BUT NO TIRES.....	1
269	ORCHARD TRAILER, WITH 45" P.T.O. SHAFT, LOW-PROFILE WHEELS AND FLOTATION TIRES .....	1
225	HYDRAULIC CONTROLLED BANDING KIT, FOR ORCHARDS, ETC. ....	1
838	HYDRAULIC CONTROLLED SIDE-PATTERN KIT, COMPLETE .....	1
2000M	GEARBOX FOR USE ON TRACTORS WITH 1,000 R.P.M. ....	1
1042P	SHAFT, 21-SPLINE, FOR 1,000 R.P.M. ....	1
1090	SMALL SEED HOPPER (MINI-HOPPER), TO BE USED FOR SPREADING SMALL SEED, AS CLOVER OR ALFALFA, AT SAME TIME OATS ARE SPREAD. (NOTICE - LID CANNOT BE USED WITH MINI-HOPPER) .....	1
1037	EXTENSION NOSE FOR MINI-HOPPER, WITH 1/4" X 1" HEXHEAD CAPSCREW AND NUT .....	1
1039	MINI-HOPPER HYDRAULIC CONTROL KIT, COMPLETE (FOR USE ON MODEL 2440) .....	1

***DESIGNS SUBJECT TO CHANGE WITHOUT NOTICE***

## **OPERATING INSTRUCTIONS AND INSTRUCTIONS TO CENTER SPREAD OF MATERIAL:**

1. RIGHT-HAND AND LEFT-HAND REFERENCE IS DETERMINED BY STANDING AT THE REAR OF THE BROADCASTER AND FACING THE DIRECTION OF TRAVEL OF TRACTOR.
2. THE MODEL 2440 HAS A CIRCULAR PLATE BOLTED TO BASE OF HOPPER THAT IS ADJUSTABLE, FOR CENTERING THE SPREAD. THIS PLATE IS NUMBERED FROM 1 TO 9 AND THE NUMBERS ARE FOUND ON THE BACK SIDE, ON OPPOSITE SIDE FROM SEED OPENING GAUGE. TO MOVE THE ADJUSTABLE PLATE, LOOSEN 4 CAPSCREWS. ALWAYS BE SURE TO TIGHTEN AFTER ADJUSTING. THE NORMAL SETTING FOR FERTILIZER IS ON 3-1/2, AND MAY BE MOVED TO A HIGHER OR LOWER NUMBER, DEPENDING UPON THE WEIGHT AND QUALITY OF FERTILIZER BEING SPREAD.
3. WHEN SPREAD IS HEAVY ON THE RIGHT SIDE, MOVE BASE PLATE RIGHT, OR CLOCKWISE, TO A HIGHER NUMBER. DO NOT MOVE OVER ONE NUMBER BEFORE CHECKING.
4. WHEN SPREAD IS HEAVY ON THE LEFT SIDE, MOVE BASE PLATE LEFT, OR COUNTER-CLOCKWISE, TO A LOWER NUMBER. DO NOT MOVE OVER ONE NUMBER BEFORE CHECKING.
5. BE SURE THE 4 CAPSCREWS ARE TIGHTENED EVENLY AFTER ADJUSTING.
6. IN EXTREME CONDITIONS TO CENTER THE SPREAD OF MATERIAL, THE BLADES ON FAN MAY BE MOVED FORWARD TO CARRY MATERIAL MORE TO THE **LEFT SIDE**. ALWAYS MOVE ALL BLADES THE SAME AMOUNT TO ASSURE EVEN SPREADING. WHEN THE BLADES ARE MOVED BACK, THIS ALLOWS THE MATERIAL TO BE SPREAD MORE TO THE RIGHT SIDE. ALWAYS MOVE THE BLADES THE SAME AMOUNT TO ASSURE EVEN SPREADING.
7. THE APPROXIMATE SETTING FOR RYE AND LIKE MATERIALS IS 3-3/4 AND THIS MAY BE VARIED SLIGHTLY TO COMPENSATE FOR THE VARIOUS WEIGHTS AND SIZES OF SEEDS. THE MODEL 2440 MAY BE USED FOR BROADCASTING CLOVERS, ALFALFA, RICE AND OTHER SEEDS, AS WELL AS FERTILIZER. SEE SEEDING INSTRUCTION CHART ON FOLLOWING PAGE AND ALSO ON HOPPER. A FERTILIZER INSTRUCTION CHART IS ALSO ON THE HOPPER. (THE FERTILIZER CHART IS FIGURED AT THE RATE OF 1 CU. FT. FERTILIZER WEIGHING 60 LBS.)
8. BENT FAN BLADES WILL CAUSE POOR SPREADING. REPLACE WHEN BENT. THE DISTANCE BETWEEN THE FAN AND BASE SHOULD NEVER BE FARTHER THAN 2-10/32" OR CLOSER THAN 2-5/32", OR IT WILL AFFECT THE SPREAD. REPLACE IN POSITION AS SHIPPED FROM FACTORY.
9. IF MATERIAL HAS A TENDENCY TO PACK, IT IS BEST TO FILL HOPPER IN THE FIELD. IF YOU DO HAVE TO TRAVEL A LONGER DISTANCE, CARE SHOULD BE TAKEN WHEN STARTING FAN AND AGITATOR SO THAT YOU DO NOT SHEAR OFF BOLT IN AGITATOR OR SPRING PIN IN P.T.O.

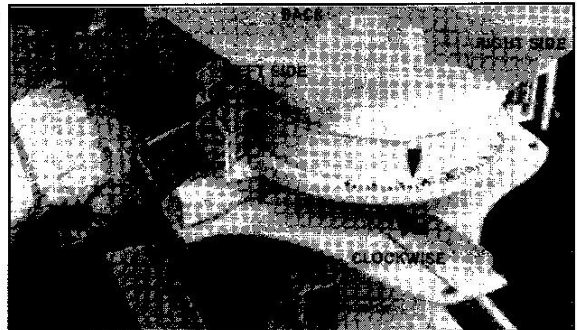

## **FOR ORCHARD USERS, HIGHWAY, ETC.:**

1. BANDING KIT, NO. 225, MAY BE ORDERED FOR "NO-CENTER" SPREADING. MAY BE SET TO SPREAD EITHER SIDE, OR BOTH SIDES AT THE SAME TIME. WIDTH OF BAND SPREADS CENTERED FROM 60 INCHES TO 34 FEET. IDEAL FOR ORCHARDS, VINEYARDS, GROVES, ETC. INSTRUCTIONS ARE INCLUDED WITH KIT.
2. A SPECIAL TRAILER NO. 269 IS AVAILABLE TO USERS WISHING TO MOUNT THE 2440 ON A TRAILER WHILE USING THE 225 BANDING KIT. THE 269 TRAILER INCLUDES LOW-PROFILE WHEELS WITH FLOTATION TIRES AND THE 45" LONG NO. 77 POWER TAKE-OFF SHAFT.
3. FOR HIGHWAY, ORCHARD AND OTHER USERS THAT WISH TO CONTROL SPREAD TO ONE SIDE (EITHER RIGHT OR LEFT), WITH PATTERN ON ONE SIDE, PART NO. 838, SIDE-PATTERN CONTROL KIT MAY BE ORDERED. INSTRUCTIONS ARE INCLUDED IN KIT.

## **MODEL 2440 BROADCASTER:**

### SERVICING AND PREPARING MODEL 2440 FOR USE:

1. GEARBOX IS SHIPPED FROM THE FACTORY WITH ONE PINT OF NO. 90 MULTIGEAR LUBRICANT. BEFORE USING, CHECK FOR PROPER LUBRICANT LEVEL. REMOVE PLUG AND FILL TO PLUG LEVEL IF LOW.
2. CUT THE WIRES HOLDING THE POWER TAKE-OFF SHAFT TO THE BROADCASTER IN SHIPMENT. THEN PLACE THE POWER TAKE-OFF SHAFT ON THE GEARBOX SHAFT AND SECURE IT WITH THE SPRING PIN PROVIDED. FOR AN EXTRA PRECAUTION, YOU CAN RUN A WIRE THROUGH THE SPRING PIN AFTER IT IS INSTALLED AND SECURE IT AROUND THE HUB OF THE POWER TAKE-OFF SHAFT.
3. UNWIRE THE UPPER END OF THE PUSH-PULL CABLE NO. 1148 WHICH IS WIRED TO THE BROADCASTER FOR SHIPPING. THEN REMOVE THE CLEVIS AND ONE 3/4" JAM NUT AND WASHER FROM THE END OF THE CABLE. NOW INSERT THE END OF THE CABLE INTO THE HOLE IN THE BRACKET BELOW THE OPENING CONTROL ARM. REINSTALL THE WASHER, JAM NUT AND CLEVIS AND MOVE THE OPENING CONTROL ARM TO THE "0" SETTING ON THE NUMBER SCALE DECAL.
4. ADJUST THE CLEVIS ON THE CABLE SO THAT THE PINHOLE AND CLEVIS HOLE ALIGN AND THAT THE OPENING PLATE (PART NO. 1024) INSIDE THE HOPPER IS JUST CLOSED. THE CLEVIS CAN BE SCREWED IN OR OUT TO ACCOMPLISH THIS SETTING. MOVE OPENING CONTROL ARM BY HAND TO MAKE SURE THAT ALL PARTS MOVE FREELY. INSTALL PULL SPRING NO. 1124 BY HOOKING THE LONG OPEN END THAT IS FASTENED TO THE OPENING PLATE, COIL END IN THE HOLE PROVIDED NEXT TO THE CABLE. THIS SPRING WILL REMOVE END-PLAY IN THE CABLE. NOW INSTALL A HYDRAULIC CYLINDER WITH AN 8" STROKE AND OPEN AND CLOSE CYLINDER SHAFT TO CHECK FOR FREE MOVEMENT, MAKING SURE THAT THE NO. 1024 OPENING PLATE DOES NOT OVER CLOSE, OR CABLE DAMAGE WILL RESULT.
5. EXTEND CYLINDER SHAFT FULLY AND CHECK THAT OPENING PLATE BARELY CLOSES. IF IT DOES NOT, READJUST AT THE CLEVIS.
6. DEPTH-BLOCKS CAN BE USED ON THE CYLINDER SHAFT FOR DESIRED OPENING. 4" OF SHAFT MOVEMENT EQUALS 1" OF OPENING PLATE MOVEMENT AND WILL SHOW EQUAL AMOUNT ON GAUGE SETTING CHART; OR 2" OF SHAFT MOVEMENT EQUALS 1/2" OF OPENING PLATE MOVEMENT; OR 1" OF SHAFT MOVEMENT EQUALS 1/4" OF OPENING PLATE MOVEMENT.
7. NEVER LOWER THE SEEDER SO THAT THE POWER TAKE-OFF SHAFT WILL COME APART.
8. WHEN RAISING THE SEEDER FOR THE FIRST TIME, MAKE SURE THE POWER TAKE-OFF SHAFT DOES NOT BOTTOM OUT. IF IT DOES, CUT OFF EQUAL AMOUNTS FROM BOTH HALVES OF THE POWER TAKE-OFF SHAFT.
9. IT MAY BE NECESSARY TO ADD FRONT END WEIGHTS ON A FEW TRACTORS THAT ARE NOT SUFFICIENTLY HEAVY IN FRONT TO HANDLE THE WEIGHT OF THE SEEDER WHEN FILLED.
10. THE SEEDER IS NOW READY TO MOUNT ON A TRACTOR WITH A 3-POINT HITCH OR WITH A FAST-HITCH (QUICK-ATTACHING COUPLER.)

### **INSTRUCTIONS FOR MOUNTING ON A TRACTOR WITH 3-POINT HITCH:**

1. THE LIFT-ARMS SHOULD BE SET FOR NO. 2 CATEGORY, OR 32-3/8" SPACING SWAY BARS, BLOCKS OR CHAINS MUST BE USED TO KEEP THE SEEDER FROM SWINGING SIDWAYS.
2. REMOVE OR MOVE DRAWBAR TO SIDE POSITION SO AS NOT TO INTERFERE WITH THE POWER TAKE-OFF SHAFT.
3. INSTALL SEEDER ON THE TWO LOWER LIFT ARMS FIRST, THEN ATTACH THE POWER TAKE-OFF SHAFT TO THE TRACTOR'S P.T.O. "CAUTION"! NOW MAKE SURE THAT THE POWER TAKE-OFF SHAFT IS NOT TOO LONG. IF THE POWER TAKE-OFF SHAFT IS TOO LONG IT WILL BOTTOM OUT AND CAUSE DAMAGE TO THE GEARBOX AND RELATED PARTS AND WILL NOT BE COVERED BY WARRANTY. IF THE POWER TAKE-OFF SHAFT IS TOO LONG YOU WILL NEED TO CUT OFF THE EXCESSIVE LENGTH BEING SURE TO CUT EQUAL AMOUNTS OFF OF EACH HALF.
4. CONNECT THE CENTER LINK ARM FROM THE TRACTOR TO THE SEEDER AND ADJUST IT SO THE FAN IS LEVEL OR THE TOP OF THE SEEDER IS SLIGHTLY TILTED TOWARD THE TRACTOR WITH THE POWER TAKE-OFF SHAFT BEING LEVEL FROM THE TRACTOR TO THE SEEDER.
5. IF YOU WISH TO RAISE THE SEEDER HIGHER FROM THE GROUND THAN HAVING THE POWER TAKE-OFF SHAFT LEVEL OR STRAIGHT, DO NOT RAISE THE SEEDER ANY HIGHER THAN WOULD REQUIRE THE POWER TAKE-OFF SHAFT TO RUN AT A 15 DEGREE ANGLE. POWER TAKE-OFF SHAFT AND GEARBOX SHAFT SHOULD RUN IN THE SAME PLANE.

### **INSTRUCTIONS FOR MOUNTING SEEDER ON TRACTOR WITH FAST-HITCH: (QUICK-ATTACHING COUPLER)**

1. INSTALL FAST-HITCH ON TRACTOR.
2. BUSHINGS SHOULD BE REPLACED ON LOWER AND UPPER MOUNTING PINS IF THEY HAVE BEEN REMOVED, OR IF NEEDED FOR FAST-HITCH.
3. BACK TRACTOR WITH FAST-HITCH UNDER 2440. RAISE FAST-HITCH SLOWLY SO THAT IT WILL LOCK INTO ALL POINTS.
4. INSTALL POWER TAKE-OFF SHAFT.
5. "CAUTION"! WHEN RAISING THE SEEDER FOR THE FIRST TIME, MAKE SURE THE POWER TAKE-OFF SHAFT DOES NOT BOTTOM OUT. IF IT DOES BOTTOM OUT IT WILL CAUSE THE GEARBOX AND OTHER PARTS DAMAGE. WHEN THE POWER TAKE-OFF SHAFT IS TOO LONG YOU MUST CUT EQUAL LENGTHS OFF OF BOTH HALVES.
6. RAISE THE SEEDER UP SO THE POWER TAKE-OFF SHAFT RUNS FAIRLY STRAIGHT OR LEVEL. FOR BEST RESULTS, THE CENTER LINK SHOULD BE SHORTENED UNTIL THE SEEDER TILTS A LITTLE FORWARD TOWARD THE TRACTOR.
7. IF YOU NEED TO RAISE THE SEEDER HIGHER FROM THE GROUND THAN ALLOWING THE POWER TAKE-OFF SHAFT TO RUN LEVEL, DO NOT RAISE THE SEEDER ANY HIGHER THAN WOULD REQUIRE THE POWER TAKE-OFF SHAFT TO RUN AT A 15 DEGREE ANGLE.



**FOR SPREADING DOLOMITE OR DEHYDRATED LIME:**

- DO NOT ATTEMPT TO SPREAD DOLOMITE OR DEHYDRATED LIME WITHOUT THE SPECIAL AGITATOR, PART NO. 158.
- INSTALL SPECIAL LIME AGITATOR IN PLACE OF REGULAR AGITATOR.
- WIDTH OF SPREAD WILL BE ABOUT 14 FEET.
- UNDER NORMAL CONDITIONS, 1200 LBS. OF DOLOMITE OR DEHYDRATED LIME WILL GO THROUGH A 1" OPENING WIDTH IN 6 MINUTES.
- FILL HOPPER IN FIELD ONLY...**DO NOT DRIVE ANY EXTRA OR UNNECESSARY DISTANCE OR THE MATERIAL WILL PACK. (THE EXTRA DRIVING WILL CAUSE THE AIR TO LEAVE THE DOLOMITE, WHICH IN TURN, ALLOWS THE MATERIAL TO SETTLE AND PACK.)
- DO NOT LEAVE ANY MATERIAL IN HOPPER OVER NIGHT OR ANY EXTENDED TIME, AS THE MATERIAL WILL SETTLE AND PACK.
- RUN TRACTOR PTO NORMALLY AT 540 R.P.M. UNDER SOME CONDITIONS, THE PTO MAY BE RUN SLOWER TO KEEP THE DUST DOWN AND STILL NOT AFFECT THE WIDTH OF SPREAD. DO NOT RUN PTO UNDER 300 R.P.M., HOWEVER.
- DO NOT USE LIME AGITATOR FOR SPREADING REGULAR FERTILIZER. BE SURE AND REPLACE LIME AGITATOR WITH REGULAR AGITATOR FOR SPREADING FERTILIZER AND BROADCASTING SEEDS.

**SEEDING CHART (SEE DECALS ON SIDE OF HOPPER FOR MORE SEEDS AND FERTILIZER)**

SEED	OPEN WIDTH	WIDTH OF SPREAD	POUNDS PER ACRE - SPEED IN M.P.H.					
			5 M.P.H.	6 M.P.H.	7 M.P.H.	8 M.P.H.	9 M.P.H.	10 M.P.H.
ALFALFA	1/8"	28 FT.	12 LBS.	10.8 LBS.	9.6 LBS.	8.4 LBS.	7.2 LBS.	6 LBS.
BLUE GRASS	1/2"	18 FT.	16	14.4	12.8	11.2	9.6	8
BROME GRASS	1/4"	10 FT.	7	6.3	5.6	4.9	4.2	3.5
CLOVER	1/8"	28 FT.	12	10.8	9.6	8.4	7.2	6
HAIRY VETCH	1/4"	40 FT.	33	29.7	26.4	23.1	19.8	16.5
HULLED LESPEDEZA	1/8"	36 FT.	13	11.7	10.4	9.1	7.8	6.5
MEADOW FESCUE	1/4"	18 FT.	13.5	12.2	10.8	9.4	8.1	6.8
OATS	1/2"	33 FT.	86	77.4	68.8	60.2	51.6	43
ORCHARD GRASS	1/4"	12 FT.	12	10.8	9.6	8.4	7.2	6
PIPER SUNDAN - SWEET	1/4"	36 FT.	32	28.8	25.6	22.4	19.2	16
RICE	1/2"	33 FT.	180	162	144	126	108	90
RYE GRASS	1/4"	18 FT.	13.5	12.2	10.8	9.4	8.1	6.8
RYE	1/2"	34 FT.	132	118.8	105.6	92.4	79.2	66
SOYBEANS	3/4"	40 FT.	120	108	96	84	72	60
WHEAT	1/2"	34 FT.	132	108	105	92	79	66

(1 LB. - 0.45 KG                      1 MILE - 1.6 KM                      1 FOOT - 30 CM)  
 (8 LBS. - 3.6 KG                      4 MILE - 6.4 KM                      12 FEET - 3.6 M)  
 (14 LBS. - 6.3 KG                      6 MILES - 9.6 KM                      18 FEET - 5.4 M)

**MAINTENANCE:**

- BEFORE STORING THE MODEL 2440, IT SHOULD BE WASHED OUT THOROUGHLY WITH WATER, MAKING SURE ALL FERTILIZER HAS BEEN REMOVED. FOR COMPLETE CLEANING, LOOSEN 4 CAP SCREWS THAT HOLD BASE PLATE TO BOTTOM OF HOPPER, SO THERE IS SUFFICIENT ROOM TO WASH OUT ALL CORROSIVE MATERIAL. WHEN DRY, OIL THOROUGHLY, **RETIGHTEN PLATE BEFORE USING.**
- SEPARATE THE POWER TAKE-OFF SHAFT HALVES AND THOROUGHLY OIL TUBING TO PREVENT "SEIZING" DURING STORAGE.

**TROUBLE SHOOTING TIPS:**

- IF SPREAD IS NOT WIDE ENOUGH, CHECK FOR SHEARED PINS.
- OTHER CAUSES OF POOR SPREAD:
  - BENT FAN BLADES.
  - FAN BLADES MOVED FROM FACTORY SETTING, (BLADES SHOULD BE IN LINE WITH LONG MARKS ON FAN.)
  - THE DISTANCE BETWEEN THE FAN AND BASE SHOULD NEVER BE FARTHER THAN 2-10/32" OR CLOSER THAN 2-5/32", OR IT WILL AFFECT THE SPREAD.
  - DO NOT RUN PTO OVER 560 R.P.M. - TOO MUCH SPEED CAUSES UNEVEN SPREADS.
  - PTO SPEED UNDER 530 R.P.M. WILL RESULT IN A NARROW SPREAD.
- THE MODEL 2440 BROADCASTER SHOULD RUN LEVEL OR TILT FORWARD SLIGHTLY. ALSO, MAKE SURE ONE SIDE IS NOT LOWER THAN THE OTHER. IF IT IS, ADJUST SEEDER SO BOTH SIDES ARE EVEN.
- IF SPREAD IS TOO MUCH ON RIGHT SIDE, MOVE PLATE TO A HIGHER NUMBER AND IF SPREAD IS TOO MUCH ON LEFT SIDE, MOVE PLATE TO A LOWER NUMBER.
- WHEN SEEDER DOES NOT FEED EVENLY:
  - CHECK MATERIAL TO SEE IF ANY FOREIGN MATTER IS IN IT.
  - CHECK TO SEE THAT AGITATOR IS BEND DOWN CLOSE TO BASE PLATE BUT DO NOT LET IT STRIKE BASE PLATE WHEN IT ROTATES.
  - OPENING MAY BE SET TOO CLOSE FOR THE MATERIAL YOU ARE SPREADING. TO OVERCOME THIS, SET THE OPENING LARGER AND DRIVE FASTER.
  - RUNNING AGITATOR WHEN NOT SPREADING WILL RESULT IN MATERIAL BEING GROUND UP AND PACKING OVER OPENING. YOU CAN "OVER-AGITATE" MATERIAL.

**ADDITIONAL TIPS:**

- FOR TRACTORS WITH 1,000 R.P.M.:  
 THE GEAR BOX IS DESIGNED SO THAT THE GEARS IN THE GEAR BOX MAY BE REVERSED FOR PROPER FAN SPEED. HOWEVER, IT REQUIRES COMPLETE DISASSEMBLY OF GEARBOX. CALL THE FACTORY FOR INFORMATION ON CONVERTING TO 1,000 R.P.M. AT 219-753-6311

(REV. 9/01)