

September 1995

FALC

SPARE PARTS BOOK

SHREDDER

S. ALCE 6400

Including the tables: N° 302-308

321-326

TAV. 326 - MOLTIPLICATORE T 301 -

SUPER ALCE 6400 - FALC -

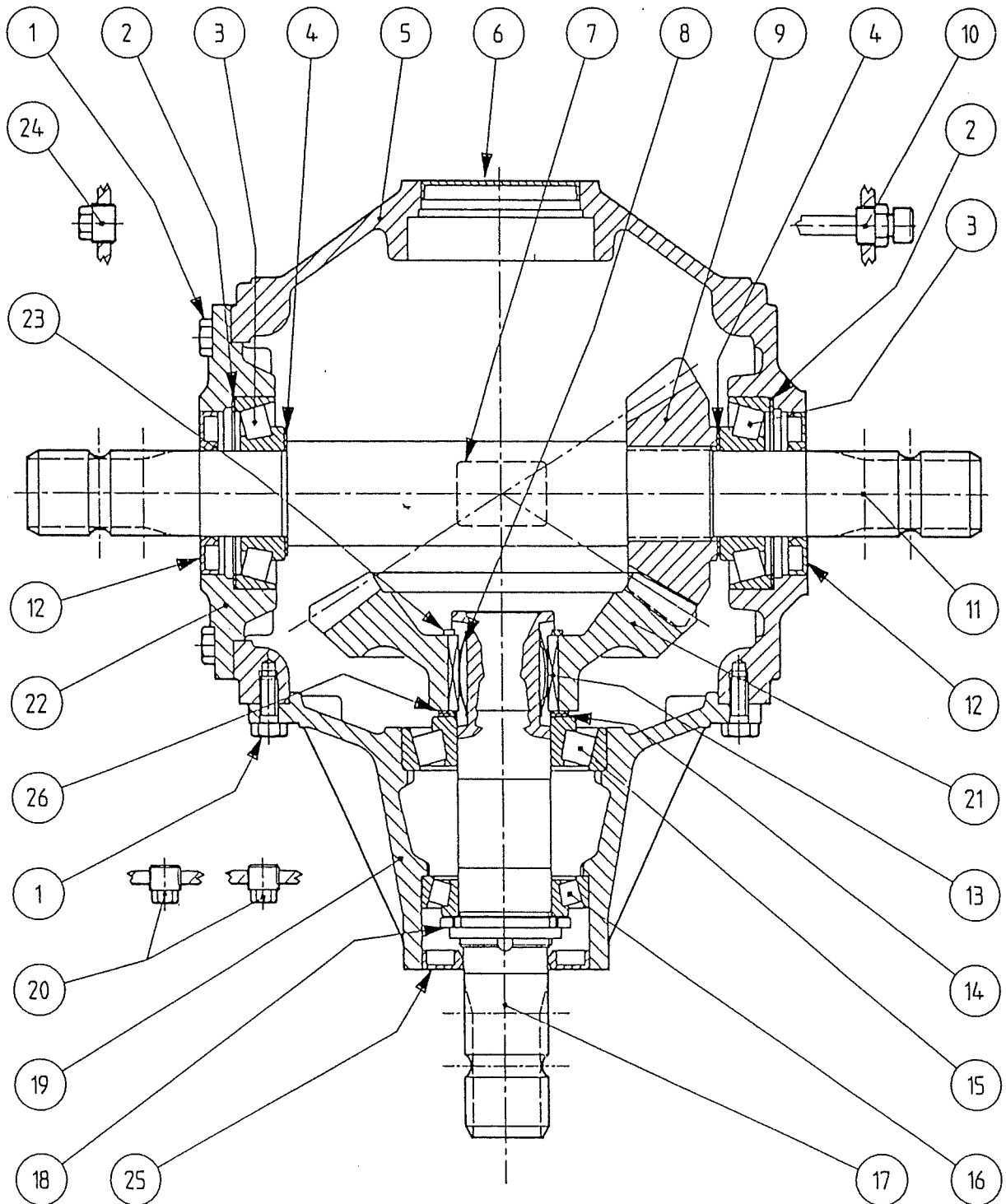

Tav. 326 07 95

Super Alce 6400 - Moltiplicatore T 301

Pos.	Codice	Denominazione
1	01.0.153	screw TE m10 L=25 UNI 5739
2	0.703.7500.00	thickness 85,3x99,7
3	06.1.039	cone-shaped bearing 30309
4	0.252.7500.00	thickness 45,3x65,3
5	0.301.0300.00	gearbox
6	0.121.7101.00	cap 85x10
7	0.124.7101.00	plate
8	0.269.7120.00	free wheel flat spring
9	0.301.5002.00	cone-shaped pinion Z=17 m=7,5
10	0.301.7101.00	cone-shaped cap 1/2" gas
11	0.301.3000.00	through-shaft 1" 3/4 Z=6 - 1" 3/4 Z=6
12	07.0.042	oil-seal BA 45x85x10
13	0.269.7119.00	tang for free wheel
14	0.712.7500.00	thickness 50,3x70,3
15	06.1.021	cone-shaped bearing 30310
16	06.1.030	cone-shaped bearing 30210
17	0.301.2003.00	shaft type B free wheel 1" 3/4 Z=6
18	0.781.7102.00	registred nut m50x1,5
19	0.301.1304.00	extention free wheel
20	8.6.5.00006	cone-shaped cap 3/8" gas
21	0.301.6005.00	cone-shaped crown free wheel Z=27 m=7,5
22	0.301.1302.00	cap
23	8.5.1.00928	seeger d 55 s=3 UNI 7436
24	8.6.5.00203	external cone-shaped cap 1/2" gas
25	07.0.031	oil-seal 45x90x10
26	0.712.7510.00	thickness 70,3x50,3x1,0
	902048	gearbox assembly -
	MIS23605	Eaton breather - requires 1/4 - 1/2 NPT bushing

TAV. N° 302 - SUPER ALCE 6400 - Ruota sterzante -

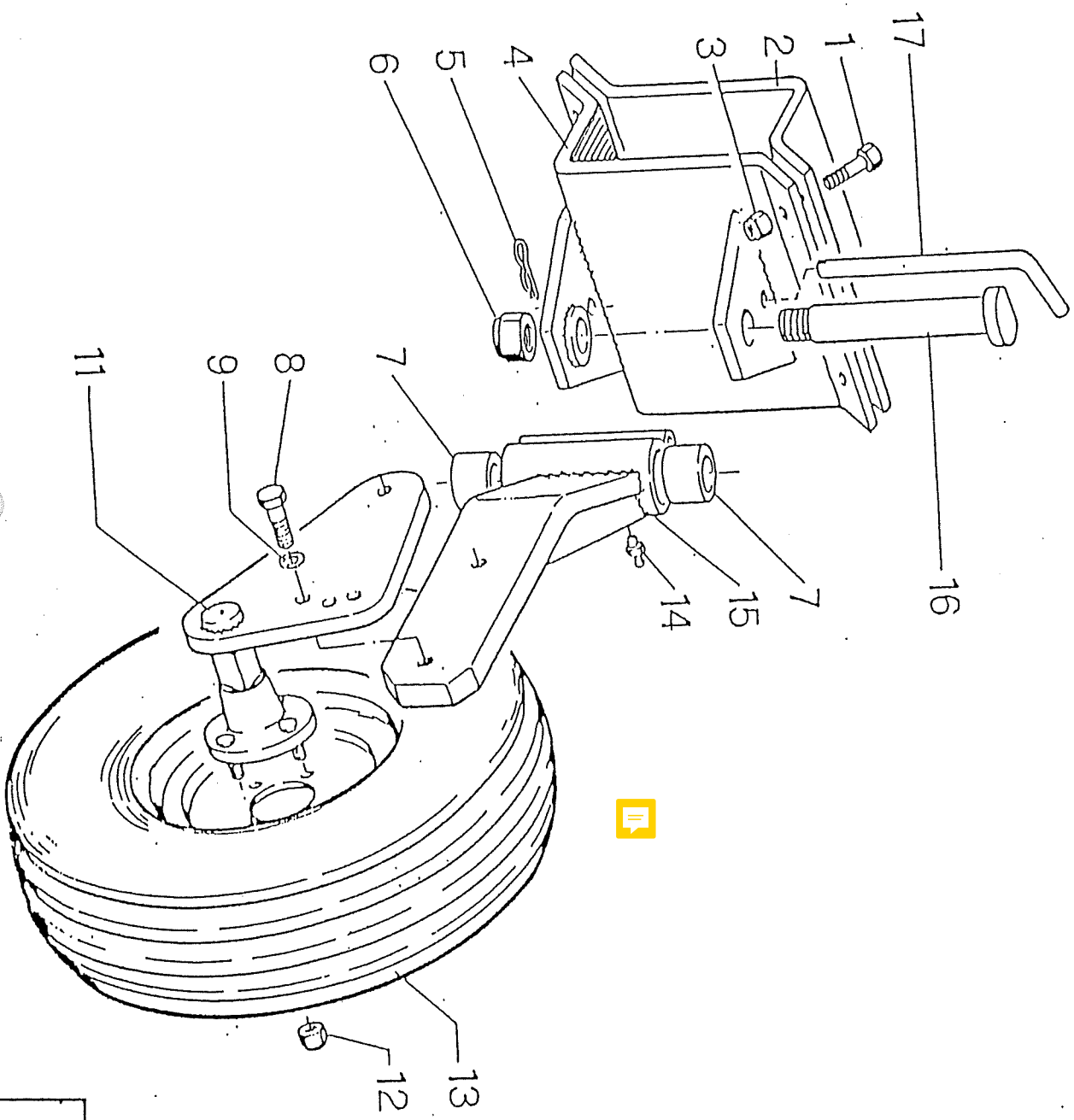

EROLLO



FAV.308 411 2446

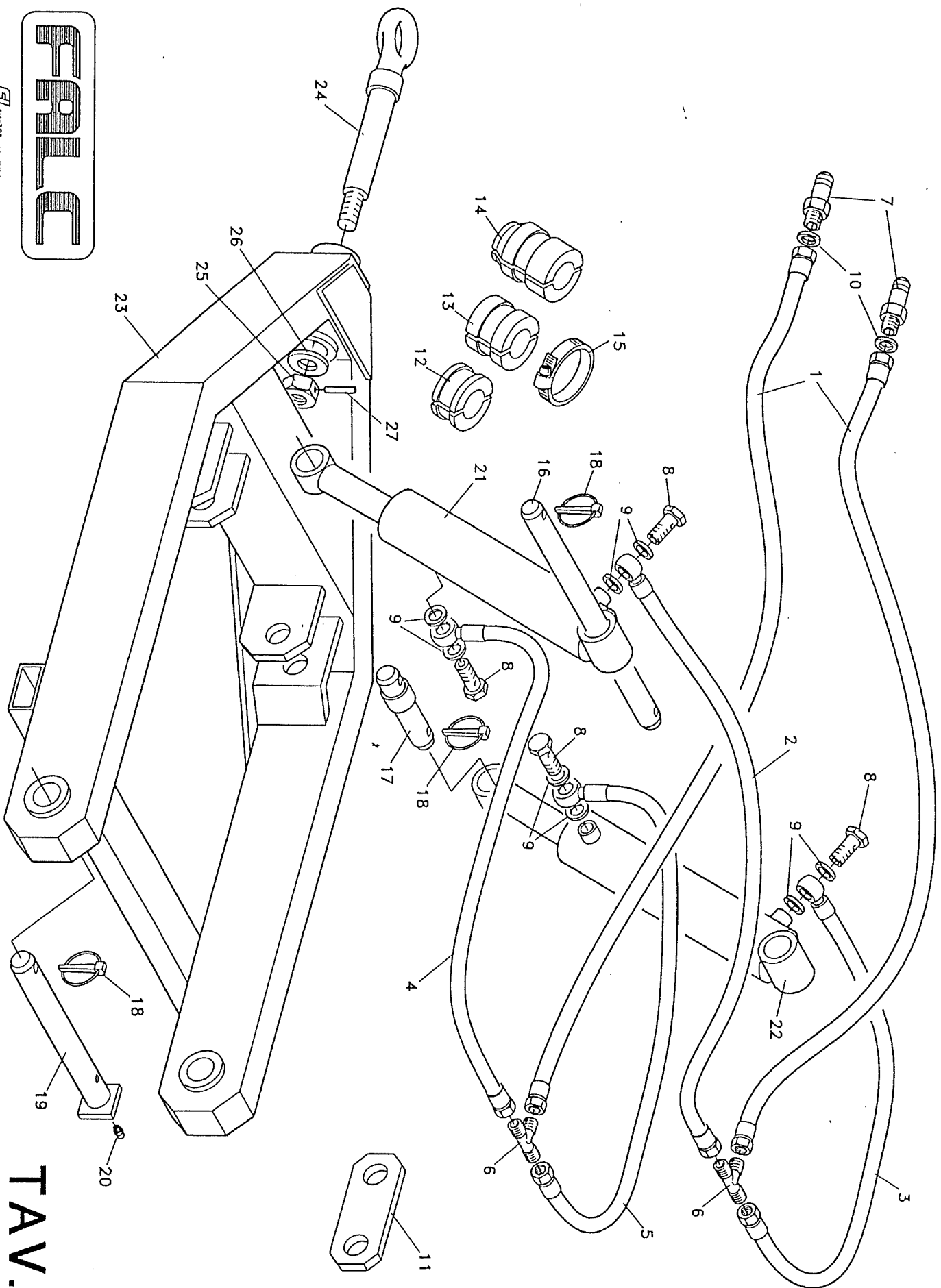

TAV.308

Tav. 308 04 95

TIMONE DI LAVORO - S. ALCE U.S.A.

Pos.	Codice	Denominazione
1	61.01.56	tubo SAE 100 R1 3/8 L=2800 FD ogiva 3/8 - MD 1/2
2	61.01.57	tubo SAE 100 R1 3/8 L=500 occhio 3/8 - FD ogiva 3/8
3	61.01.58	tubo SAE 100 R1 3/8 L=800 occhio 3/8 - FC 90° ogiva 3/8
4	61.01.59	tubo SAE 100 R1 3/8 L=1000 eye 3/8 - FD ogive 3/8
5	61.01.60	tubo SAE 100 R1 3/8 L=1300 eye 3/8 - FC 90° ogive 3/8
6	09.1.301	union T 3/8 male
7	09.1.506	quick linkage male part 1/2 spheric
8	09.1.051	drilled screw 3/8"
9	09.1.002	chopper washer 3/8"
10	09.1.004	chopper washer 1/2"
11	61.01.11	fixing plate working drawbar
12	61.01.62	piston's spacer of working drawbar H=30
13	61.01.63	piston's spacer of working drawbar H=60
14	61.01.64	piston's spacer of working drawbar H=100
15	09.1.661	standard hose clamp art. 3557
16	61.01.09	upper pin for drawbar's piston and 3rd upper point
17	61.01.10	lower pin drawbars pistons
18	05.3.402	pin d 10 L=58 art. 104
19	61.01.66	drawbar pin
20	09.2.501	lubricator m 6
21	61.00.65	right piston of drawbar
22	61.01.65	left piston of drawbar
23	61.01.61	working drawbar
24	10.1.602	rotating eye for drawbar art. 2752
25	02.0.008	high exagonal nut m33 h=33 UNI 5587
26	04.1.212	washer UNI 6592 cat.A d 33 (34x60x5)
27	05.2.011	elastic pin normal type d 5 L=45 UNI 6874
28	SEALKITSALCE6400	Seal kit for left cyl.
29		
30		
31		
32		
33		
34		
35		
36		
37		
38		
39		
40		
41		
42		
43		
44		
45		
46		
47		
48		
49		
50		
51		
52		
53		
54		

PARLOR

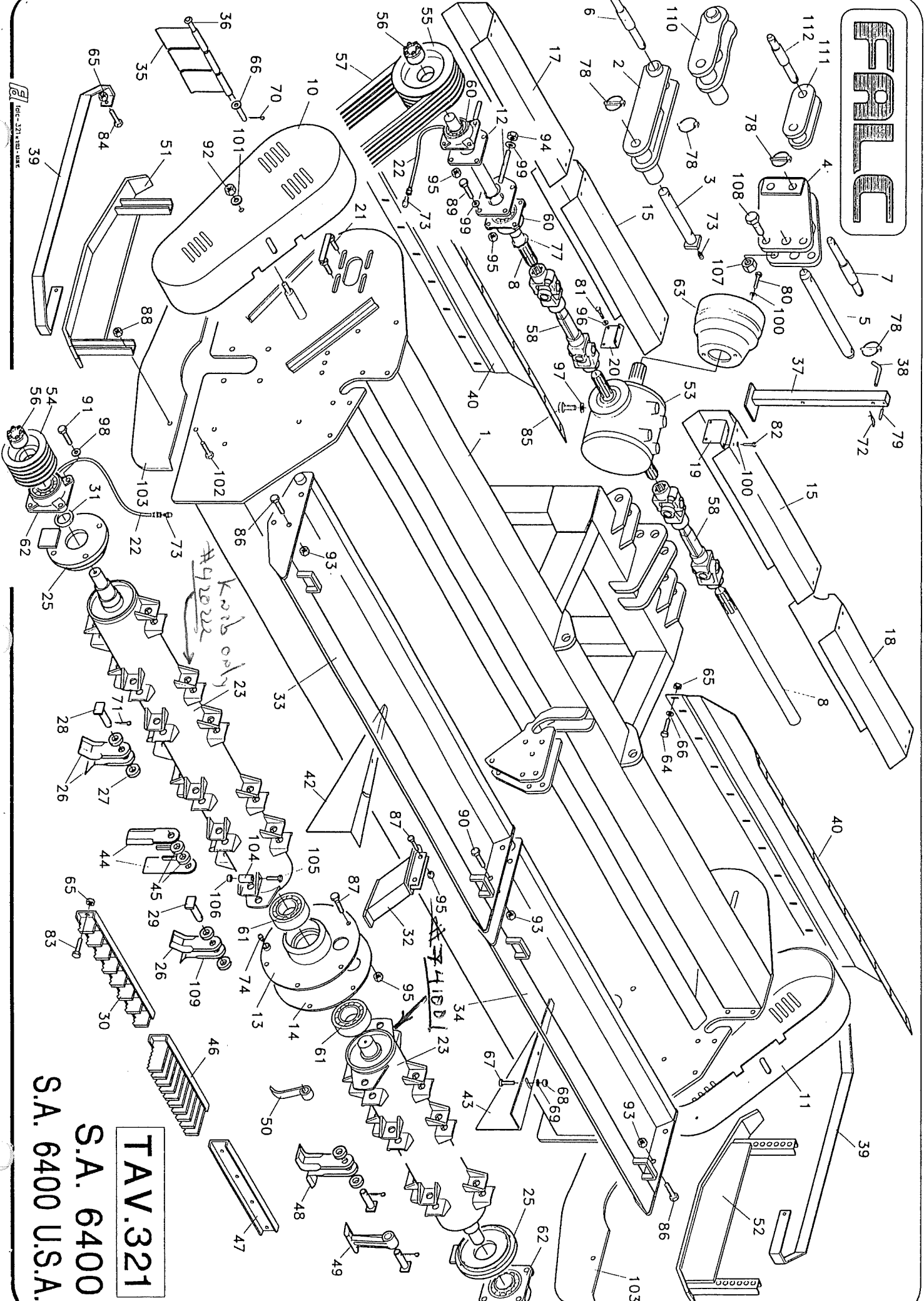

TAV.321

S.A. 6400

U.S.A.

Tav. 321 06 95				SUPER ALCE 6400 - 6400 U.S.A.			
Pos.	Codice	Denominazione					
1	61.01.76	frame 6400					
2	49.06.09	3rd lower point linkage II and III cat. USA					
3	61.01.66	drawbar pin					
4	49.06.33	upper 3 points linkage USA					
5	61.01.09	upper pin of drawbars pistons and 3rd upper point					
6	25.05.55	lower pin II and III cat.					
7	58.08.72	upper pin II and III cat. USA					
8	61.00.24	upper transmission shaft L = 1734					
10	43.04.60	right timing case					
11	49.07.18	left timing case					
12	61.01.77	flange for support UCF 210					
13	61.00.06	central bearing's right support					
14	61.01.78	central bearing's left support					
15	61.01.22	shafts protection (near gearbox) L = 1537,5					
17	61.00.90	right external shafts protection L = 1410					
18	61.00.91	left external shafts protection L = 1410					
19	61.01.79	right assembly support for shafts protection					
20	61.01.80	left assembly support for shafts protections					
21	61.01.81	adjustment screws - extension multiplier					
22	49.03.52	lubricator extension					
23	61.00.03	rotor 6400					
	61.01.87	rotor 6400 USA					
25	41.04.65	flange for support UCF 212					
26	43.01.51	blade type 01					
27	43.00.65	spacer blade type 01					
28	42.03.35	blade holder pin					
29	49.06.37	central blade holder pin					
30	61.01.52	right comb counterblade for blades 01 L = 3185					
	61.01.53	left comb counterblade for blades 01 L = 3185					
31	36.00.30	thickness for rotor's adjustment (D 76 d 60,5) s = 1					
	5.709	thickness for rotor's adjustment (D 76 d 60,5) s = 2					
	36.00.31	thickness for rotor's adjustment (D 76 d 60,5) s = 3					
32	41.06.85	straw divider					
33	61.01.83	right timing case 6400					
34	61.01.84	left timing case 6400					
35	41.00.86	} see table for quant.					
	41.07.22					lower protection L = 90	
	41.00.87					lower protection L = 139	
36	61.01.37	lower protection's pin 6400					
37	61.01.40	support					
38	61.01.88	support's pin					
39	43.08.94	lateral against accidents protection					
40	61.00.70	wear sheet L = 3160					
42	41.04.23	right directional fin with slot					
43	41.04.24	left directional fin with slot					
44	43.00.83	streight blade type 02					
45	43.01.44	blade spacer type 02					
46	61.01.93	right comb counterbladefor blade 02 L = 3185					
	61.01.94	left comb counterblade for blade 02 L = 3185					
47	61.00.73	sleek counterbladeL = 3185					
48	43.07.66	blades type 05					
49	43.02.51	drop-forged hammer					
50	43.08.53	ventilation blade					
51	43.00.39	right skid					

Pos.	Codice	Denominazione
52	43.00.40	left skid
53	90.2.048	multiplier T 301 -internal free wheel
54	08.2.005	pulley SPB 200/5 VIBIK (hole d 80)
55	08.2.015	pulley SPB 250/5 VIBIK (hole d 80)
56	08.3.005	self centering locking devices VK 156 (45x80)
57	08.1.004	transmission belt SPB 1750
58	10.0.457	cardan ByPy 7.106 116 00 016 016
60	06.4.004	square flange's support UCF 210
61	06.4.001	bearing with floating support UCC 212
62	06.4.005	square flange support UCF 212
63	10.0.501	plastic protection pto
64	01.1.101	screw TE m12x1,25 L=25 tf UNI 5740
65	02.5.002	nut metalbloc m12x1,25 h=11
66	04.1.005	common washer cat.C d 16 (17x35x3)
67	01.0.154	screw TE m10 L=25 tf zink plated UNI 5739
68	02.2.002	stop nut m10 h=12,3 UNI 7473
69	04.1.233	zink plated washer UNI 6593 cat C d 10 (11x30x2,5)
70	05.3.004	split pin d 4 L=30 UNI 1336
71	05.3.012	split pin d 5 L=40 UNI 1336
72	05.3.202	spring split pin 4 L=76 art.114
73	09.2.501	lubricator m 6
74	09.2.503	lubricator m10
77	05.0.031	externalseeger d 50 s=2 UNI 7435
78	05.3.402	pin d 10 L=58 item 104
79	05.2.113	elastic pin heavy type d 8 L=70 UNI 6873
80	01.0.126	screw TE m 8 L=14 tf zink plated UNI 5739
81	01.0.101	screw TE m 8 L=16 tf UNI 5739
82	01.0.102	screw TE m 8 L=20 tf UNI 5739
83	01.1.102	screw TE m12x1,25 L=30 tf UNI 5740
84	01.1.104	screw TE m12x1,25 L=35 tf UNI 5740
85	01.0.302	screw TE m16 L=35 tf UNI 5739
86	01.1.217	screw TE m16x1,5 L=45 tf zink plated UNI 5740
87	01.1.218	screw TE m16x1,5 L=50 pf UNI 5738
88	02.5.003	nut metalbloc m14x1,5 h=12
89	01.1.209	screw TE m16x1,5 L=65 pf UNI 5738
90	01.1.220	screw TE m16x1,5 L=80 pf zink plated UNI 5738
91	01.1.260	screw TE m18x1,5 L=55 pf UNI 5738
92	02.2.005	stop nut m16 h=18 UNI 7473
93	02.3.004	stop nut m16x1,5 h=18 UNI 7473
94	02.0.005	high exagonal nut m16 h=16 UNI 5587
95	02.5.004	nut metalbloc m16x1,5 h=14
96	04.0.002	heavy grower d 8
97	04.0.006	heavy grower d 16
98	04.0.007	heavy grower d 18
99	04.1.202	washer UNI 6592 cat.A d 16 (17x30x3)
100	04.1.226	zink plated washer UNI 6593 cat.C d 8 (9x24x2)
101	04.1.227	washer UNI 6593 cat.C d 16 (18x48x4)
102	01.1.151	screw TE m14x1,5 L=30 tf UNI 5740
103	49.04.09	lateral against accident protection sheet
104	49.06.43	spacer of central blade holder pin (only for USA)
105	01.1.056	screw TE m10x1,25 L=80 pf UNI 5738 (only for USA)
106	02.5.001	nut metalbloc m10x1,25 h=9 (only for USA)
107	02.4.007	nut metalbloc m24 h=21,5 (only for USA)
108	49.06.42	screw TE m24 L=65 for 3rd upper point (only for USA)

Tav. 321 06 95

SUPER ALCE 6400 - 6400 U.S.A.

Pos.	Codice	Denominazione
109	49.06.40	short blade 01 for S.A. type USA
110	25.05.40	3rd lower point linkage II-III class
111	61.01.44	unit arm 3rd upper point II-III class
112	61.00.51	upper pin II-III class
R+P 765 8086 R1 T10509 - pull type CV PTO (CV Joint at Tractor end)		