

# USE AND MAINTENANCE MANUAL

1.1. Manufacturer: **FALC S.r.l.**  
via Proventa n.41 - Faenza (Ravenna) - ITALIA -  
Tel. ++39 0546 29050  
Fax ++39 0546 663986  
e-mail: info@falc.eu  
www.falc.eu

1.2. Series : **ALCE SHREDDER**  
**SUPER ALCE SHREDDER**  
**KRONOS SHREDDER**

1.3. Model:

1.4. Series number:

## **CAREFULLY NOTE:**

- THIS MANUAL MUST ACCOMPANY EACH EXAMPLE OF THE ABOVE MENTIONED SERIES.
- IN ORDER TO ENSURE A COMPLETE UNDERSTANDING OF THE MACHINE'S CORRECT FUNCTIONING THE USER MUST FULLY READ EACH SECTION OF THE MANUAL.
- PARTICULARLY IMPORTANT NOTES REGARDING SAFETY ARE WRITTEN IN BOLD PRINT.
- ANY USERS WHO MUST CARRY OUT PARTICULAR OPERATIONS ON THE MACHINE FOR WHICH NO SPECIFIC INSTRUCTIONS HAVE BEEN SUPPLIED MUST DIRECTLY ASK OUR SALES OR TECHNICAL OFFICE.

## **INDEX**

1. General indications
2. Use conditions
3. Operator conditions
- 4.1. Connection of the Pellicano shredder to tractor
- 4.2. Pellicano shredder use
- 4.3. Using the shredder with rear hood open
- 4.4. Detaching the shredder from the tractor
- 4.5. Transport
- 4.6. Work height adjustment
- 4.7. Maintenance and repairs
5. Guarantee
6. Norms to follow for correctly ordering spare parts
7. Safety pictograms



## 2. CONDITIONS OF USE

FALC shredders are built to be coupled to an ideal tractor provided with a 3-point hitch and a Cardan shaft transmission.

The Kronos, Alce, Super Alce shredder series, are used to shred the remains after maize, wheat, Soya bean, cotton, sunflower, artichokes, tobacco harvests, etc., to allow a better formation of the humus necessary for the soil fertility, for the elimination of parasites and to achieve the optimal condition that restores the land for further cultivation. They are also used to shred grasses and pruning remains in fruit orchards and vineyards.

**Any other use of the shredders is to be considered illegal and prohibited by the manufacturer.**

Model	Hp Tractor	Kw Tractor	Weight with wheels	Work dimensions
Kronos 8000	160-280	118-206	Kg 4100	mm 8018
Kronos 6400	120-180	88-132	Kg 3620	mm 6441
Kronos 5400	120-180	88-132	Kg 3100	mm 5541
Kronos 4800	100-160	73-118	Kg 2820	mm 4821
Kronos 4000	100-160	73-118	Kg 2500	mm 4011
Super Alce 4800	100-160	73-118	Kg 2380	mm 4821
Super Alce 4200	100-160	73-118	Kg 1960	mm 4184
Super Alce 4000	100-160	73-118	Kg 2190	mm 4011
Super Alce 3200 DT	70-140	52-103	Kg 1620	mm 3201
Super Alce 3200	70-140	52-103	Kg 1450	mm 3201
Super Alce 2500	60-120	44-88	Kg 1135	mm 2481
Alce 3200	70-120	52-88	Kg 1245	mm 3201
Alce 2700	70-120	52-88	Kg 1100	mm 2661
Alce 2500	50-80	37-59	Kg 1000	mm 2481
Alce 2300	50-80	37-59	Kg 920	mm 2301
Alce 1950	50-80	37-59	Kg 760	mm 1941
Alce 1600	50-80	37-59	Kg 630	mm 1581

To achieve the lifting capacity and tractor stability it is necessary to respect the following conditions:

$$M \times s \leq 0,2 T \times i + Z (d + i)$$

$$M \leq 0,3 T$$

$i$  = tractor wheels wheelbase

$T$  = Tractor mass

$d$  = distance of front axis from ballast

$Z$  = ballast mass

$s$  = protrusion of shredder rear axis

$M$  = shredder mass

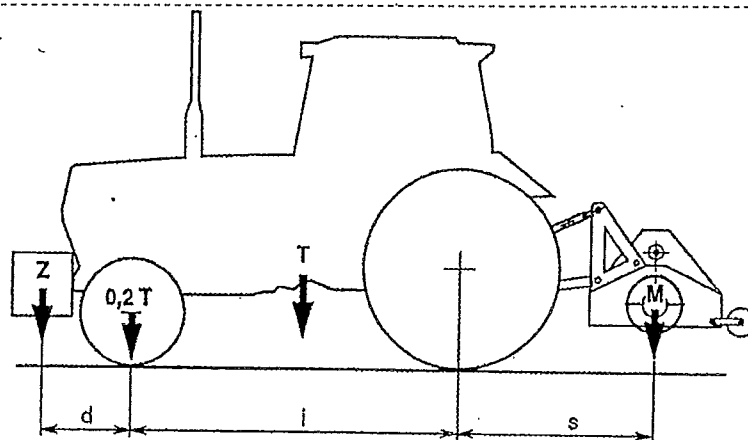

**IT IS ABSOLUTELY FORBIDDEN TO ALLOW PERSONS, ANIMALS OR THINGS TO CLIMB OR BE TRANSPORTED ON THE ALCE, SUPER ALCE, KRONOS SERIES SHREDDERS**

### **3. CONDITIONS FOR THE OPERATOR**

- a) During the use of the shredder, the operator must remain on the tractor in the driver's position. **The operator cannot leave the driver's position on the tractor if he has not disengaged the power take-off from the tractor itself and has not waited until the moving parts of the shredder (rotor, etc.) are completely stationary. The stop time of the moving parts of the shredder is roughly 3 minutes.**
- b) Under normal conditions, that is, with the rear lid closed, the operator must ensure that when starting up the shredder and during its operation, there are no persons within a radius of 20 m around the machine. **The operator must immediately stop both the tractor as well as the shredder if one or more persons enter within a 20 m radius around the machine.**
- c) The operator must not activate the hydraulic lift of the tractor without having first disengaged the tractor's power take-off. **Before lifting the shredding machine from the ground using the tractor's hydraulic lift, the operator must ensure that the power take-off is disengaged.**
- d) It is strictly prohibited to go in reverse while continuing to chop; i.e. with the tractor PTO engaged. Before starting the reverse manoeuvre, always wait till the rotor has completely stopped.
- e) The front part of the machine is equipped with oscillating protective devices designed to prevent any material from being thrown out while working. You need to check these devices constantly to make sure that they are free to oscillate and that they are not deformed (crooked or bent). This check is very important particularly on stony ground where these protective devices are subject to numerous impacts during normal work. If the protective devices are deformed, they must be replaced immediately.

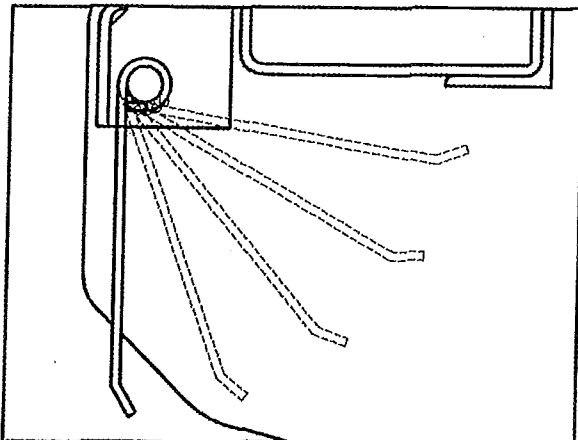

- f) To protect your eyes from any objects thrown out from the shredder while working, always wear suitable work goggles.



#### 4.1. CONNECTION OF THE SHREDDER TO THE TRACTOR:

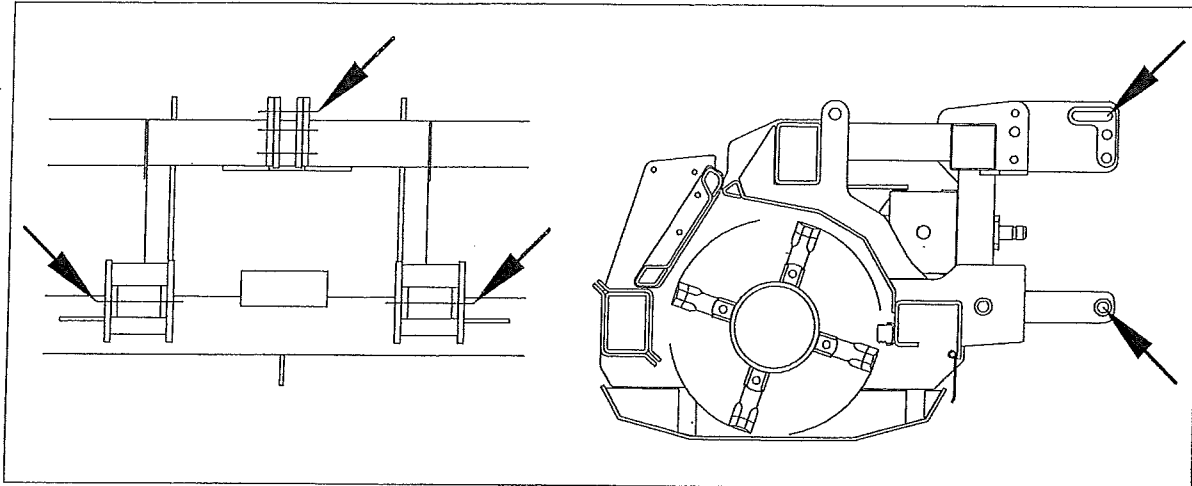

- a) All Falc shredders can be mounted onto any type of tractor provided it is supplied with a 3-point universal hitch
- b) The shredder must be positioned on level ground on supporting legs.
- c) The tractor must approach the shredder in reverse until its arms are in correspondence with those of the shredders 3 point. Any operator on the ground must maintain a distance of at least 5 m from the machine.
- d) Position the lower 3 point pin and block with the split pins provided.
- e) Connect the upper arm of the tractor to the upper dowel of the 3 point, adjusting so that the machine assumes a horizontal position with respect to the ground.
- f) Position the cardan shaft and ensure that its ends are well connected to the power take-off of the tractor and the multiplier. Fix the anti-rotation chains (catenelle) on the cardan to both the tractor and shredder side. **The tractor engine must be off during this phase so that the power take-off is not activated by any wrong manouevre.**
- g) After the completion of this operation the tractor's hydraulic lift may be activated just enough to free the support legs which must then be completely raised and blocked with the pins provided.
- h) For the series machines  
 Tractor power take-off (PTO) = 1000 revolutions/minute for Kronos, Super Alce, Alce 32-27  
 Tractor power take-off (PTO) = 540 revolutions/minute for Alce 2500-2300-1950-1600

The Super Alce 2500 – 2700 – 3200 – 3200 DT and Alce 3200 shredder series are equipped with a bar for a “rapid” attachment to the lower arms of the tractor. By leaving this bar attached to the lower arms of the tractor a quick attachment of the shredder is rendered possible. To disconnect the shredder from the tractor it is necessary to manually free the lower bar from the 3 point attachment.

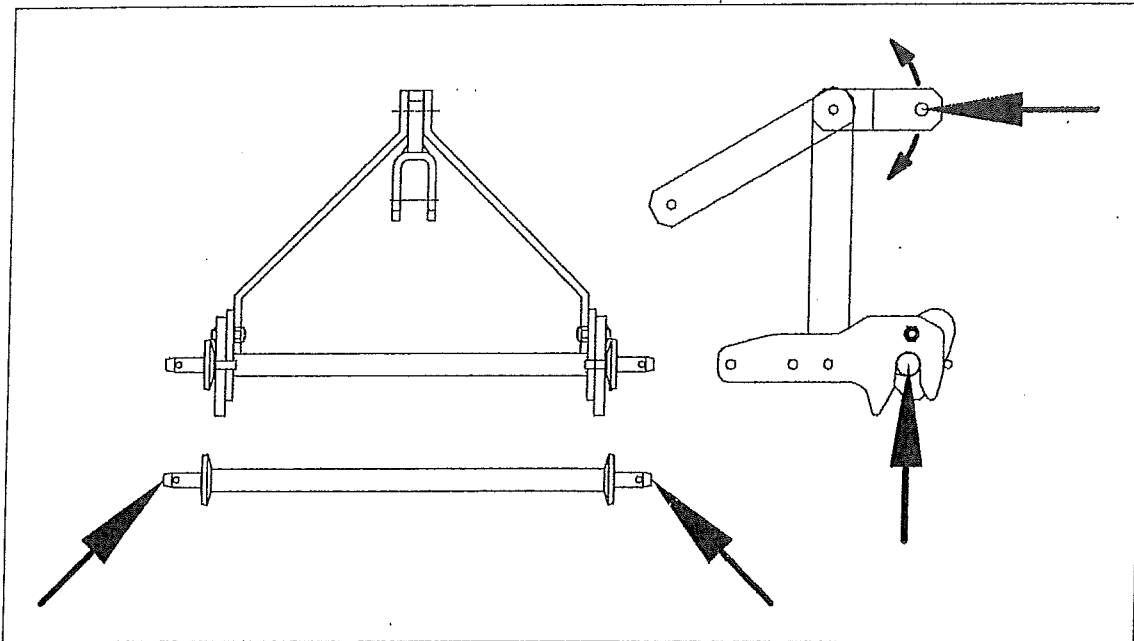

#### 4.2. USING THE SHREDDER

After having correctly connected the shredder to the tractor, the operator can start to work, always respecting the conditions mentioned in point 3 (point 4.3) if working with the lid open).

The tractor's advancement speed is independent of the shredder; it is up to the operator to judge and determine the best machine output depending on some factors, namely the tractor's power, height of the remains to be shredded, adjustment of the working height, etc..

Here are some examples of speed:

- a) Shredding of pineapple plantation  $\Rightarrow$  max 1 – 1,5 km/hour
- b) Shredding of cotton plantation (per row)  $\Rightarrow$  max 8 – 10 km/hour

For reasons of space it is sometimes necessary to disassemble the machine's lateral protections whilst it is in transport. If this is the case, the protections will be placed in a very prominent position on the machine on which they are to be reassembled and it is the responsibility of the consignee to ensure that this operation is carried out. For the correct positioning of the lateral protections please refer to the spare parts table of the shredder concerned. The protections are provided with the screws and nuts necessary for blocking.

#### 4.3. USE WITH THE REAR LID OPEN.

The Kronos, Super Alce and Alce shredders, for particular needs of the user, provides for the removal of the rear lid thus obtaining a distribution of the shredded material up to about 20 m from the shredder itself.

To remove the rear lid the operator must act as follows:

- a) (If the machine is on) Completely stop the shredder and switch the tractor off. Wait for approximately 3 minutes, until the rotor is completely still.
- b) Unscrew the relative rear lid fixing bolts with the appropriate keys.
- c) Kronos – Super Alce: position the lid in the "open" position and fix with the appropriate screws.
- d) Alce: remove the lid.
- e) **Carefully check against the possibility that propelling material might be cast towards persons, animals or objects where this could cause damage (e.g. trees of a nearby farm, agricultural sheds, various parked vehicles, etc.). The minimum distance required between the shredder in operation and the nearest persons, animals or things, must be at least 50m.**

- f) After the operator has carried out all these procedures, he can again climb onto the tractor and switch it on.
- g) During operation with the rear lid open, the operator must ensure that the conditions mentioned in point (e) are constantly adhered to. The operator must further ensure that the minimum distance between the shredder and any place of passage, namely a street, a trail, etc., is at least 50 m.
- h) Even if only one of the above mentioned conditions is not adhered to, the operator is obliged to stop the shredder and switch the tractor off.
- i) It is further prohibited for the operator to leave the tractor's driver's position without having previously stopped the shredder and waited until the rotating parts of the same have come to a complete standstill (about 3 minutes).

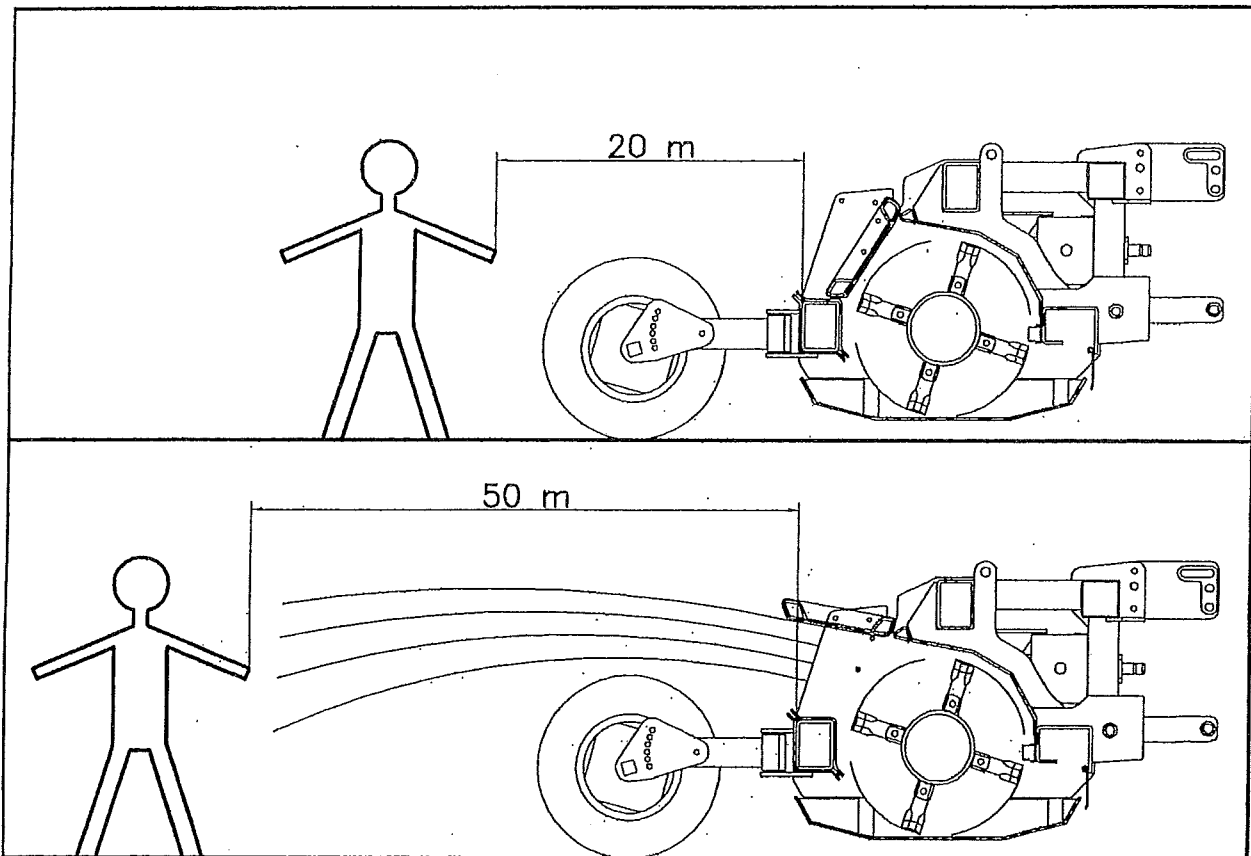

#### 4.4 DISCONNECTION OF THE SHREDDER FROM THE TRACTOR

The following are necessary precautions for a correct disconnection of the shredders from the tractor:

- a) Stop the tractor on level ground, activate the handbrake, turn the engine off and disconnect the power take-off.
- b) Place the shredder on the ground ensuring that its position is both stable and horizontal
- c) Stop the tractor motor and wait for about 3 minutes until all the moving parts of the shredder stop.
- d) Position the resting feet.
- e) Disconnect the cardan joint from the tractor's power take-off and place it in the appropriate shredder support.
- f) Disconnect the shredder from the 3-point hitch of the tractor first by sliding out the split pins that block the dowels and then by removing the pins themselves.

- g) Climb onto the tractor again and move it forward to completely free the tractor's arms from the 3rd point of the shredder.

#### 4.5. TRANSPORT

During operation, the shredders rest on the wheels at the rear, on the roller as well as on the lateral slits. In the front they are kept lifted by the tractor's hydraulic hitches' arms .

During transport the shredders are completely supported by the tractor (see point 2).

Due to the handling which is necessary during the loading, unloading and storage ensure that only the appropriate equipment which can support the weight of the machine itself is used and use the pegs which are purposely positioned on the machine.

##### 4.5.1. Using the Transport trolley for the Kronos, Super Alce 4800-4000-3200, Alce 3200

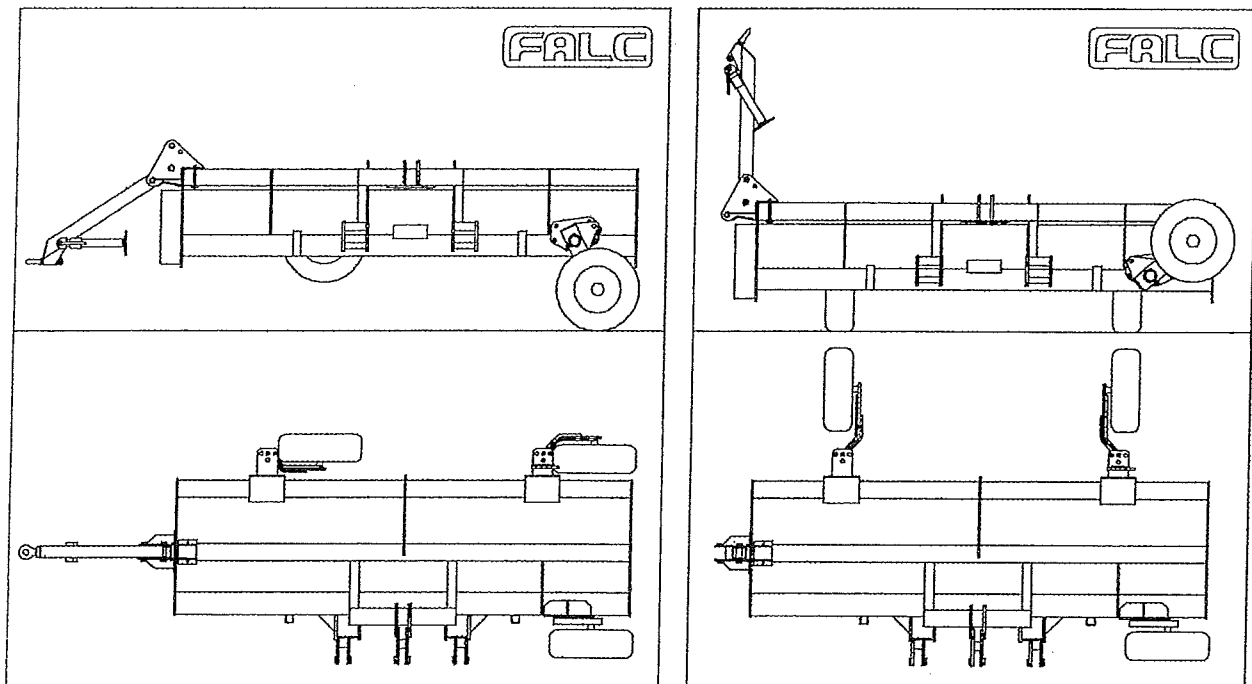

There is an easy assemble and use transport trolley available for the transport of the machine using the drive hook of the tractor. The more recently produced shredders are equipped with a series of holes to bolt the base of the rudder and the wheels. The transport trolley may be requested at the moment of purchase or can be applied directly by the user. In this case the user must check to ensure that the machine in his possession is adequately equipped.

The following diagrams represent the position of the rudder and the wheel during work and during transport. To rotate the rudder and the wheels from the work position to the transport position and vice versa, it is necessary that the machine is kept lifted by the tractor arms.

#### 4.6. ADJUSTING THE WORKING HEIGHT

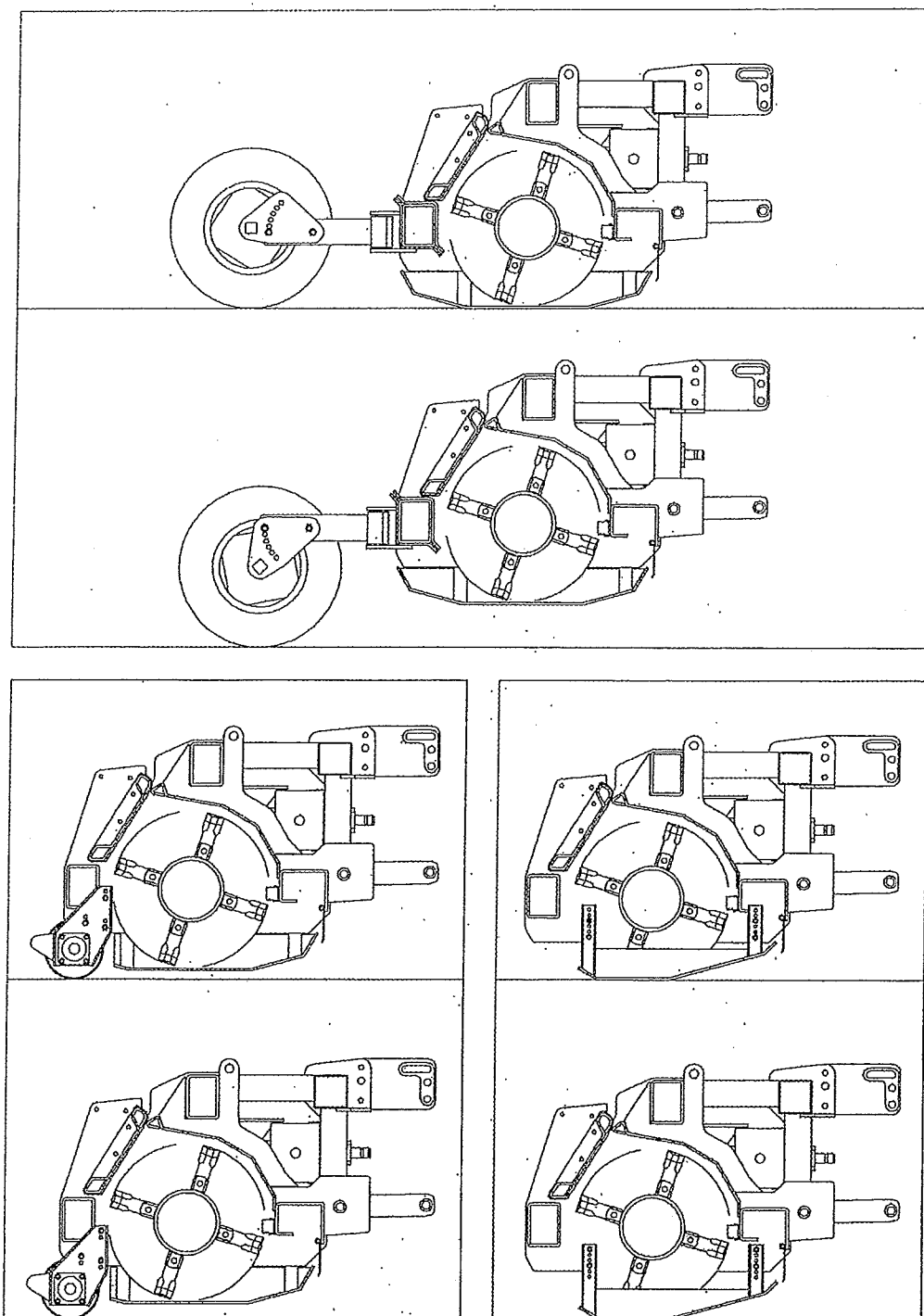

Before using the shredder it is necessary to take particular care in adjusting the working height.

- a) The working height adjustment is carried out by moving the connection flanges of the wheels, of the slides and of the roller by one or more holes.
- b) The working height adjustment is correct when the cutters or the hammers skim the ground without actually touching it. If the rotating movements touch the ground due to an incorrect adjustment, the result will be a greater power consumption by the tractor and a faster wear rate of the same rotating movements.
- c) The machine must always be in a horizontal position with respect to the ground.



#### 4.7. MAINTENANCE AND REPAIRS

**Before approaching the machine to carry out any maintenance or repairs, it is compulsory to take some precautions:**

- a) **Stop the tractor on level ground**
- b) **Place the shredder on the ground**
- c) **Activate the handbrake**
- d) **Disengage the p.t.o**
- e) **Turn the engine off**
- f) **Wait for about 3 minutes until all moving parts of the shredder have stopped.**

**In case of specific maintenance or repair work where it is necessary that the machine is lifted from the ground or turned around, it is indispensable to use the suitable equipment built for such purposes. It is always recommended that the area sales assistance or ideally equipped mechanical workshops are consulted. The machine weight is in point 2 of this manual.**

**For intervention on parts of the machine which may reach elevated temperatures such as the multiplier, the bearings, the belts etc., wait until they have cooled. The cooling time for these parts may vary depending on the work carried out before stoppage as well as external atmospheric conditions.**

##### 4.7.1. Maintenance

Even though all the shredders are delivered well greased and lubricated, hereafter is a list of rules which must strictly be adhered to, so as to obtain better results.

- a) **After the first hour of operation**
  - Check that all bolts and screws are correctly tightened.
- b) **Daily**
  - Check the oil level in the transmission box.
  - Lubricate the Cardan joint (see the specific Instruction manual relative to the Cardan joint)

**WARNING :** the Cardan joint is in general supplied by FALC and is suitable for the effective power required for the tractor-shredder link-up. In case of replacement always use a Cardan joint with characteristics not inferior to those of the original Cardan shaft.
- c) **Every 8 hours of work**

Grease the rotor supports using the appropriate grease nipples indicated on the machine. Grease in moderation applying a little grease at a time  
Grease all of the points indicated on the machine.
- d) **Every 8 working hours**
  - Check the belts' tension so as to prevent premature wear of the belts themselves and the pulleys. The correct tension of the belts is achieved when, by pushing on the central point between the pulleys, the belt yields a maximum of 10 mm.
- e) **Every 300 working hours**
  - Change the oil in the transmission box.
  - Check that the breather plug of the multiplier is free of dust and earth internally. If in doubt replace the breather plug.

On delivery the transmission box is lubricated with Mobil Gear 634 SAE 140 oil.  
**WARNING:** Do not disperse the used oil but use the appropriate means provided for its disposal.
- f) **If vibrations should be noted during work IMMEDIATELY STOP THE SHREDDER AND DISCONNECT THE P.T.O.** Check for breakage or excessive wear of the cutters or of the hammers. If necessary immediately provide for a partial or total replacement of these, taking the

utmost care to maintain the balance of the rotor, that is, by replacing the broken cutters (hammers) and those diametrically opposite the broken ones.

- g) Further check if there is residue or encrustation on the knives, hammers or on the rotor. If this is so clean immediately.
- h) Prior to a period of inactivity, it is recommended that the machine is accurately cleaned machine of remains accumulated during operation. During the period of inactivity, it is recommended that the machine is protected from atmospheric agents.

#### 4.7.2. Possible causes of inconveniences and relative interventions.

##### **If the shredder vibrates in an evident manner**

###### CAUSE :

Breakage of one or more cutters (hammers) which causes the rotor to lose its balance.  
The bearings of the rotor's supports are worn.  
Remains and encrustations are visible on the cutters (hammers) and/or the rotor.

###### INTERVENTION :

Replacement of the broken cutters (hammers) and of those diametrically opposite the broken ones.  
Replacement of the supports.  
Cleaning of the cutters (hammers), cleaning of the rotor

##### **If the rotor rotates at a speed lower than specified**

###### CAUSE :

The belts have become loose.  
Excessive wear of the belts and pulleys.

###### INTERVENTION :

Reset the correct tension of the belts.  
Replace any worn parts.

##### **An excessive wear of the cutters (hammers) is noted.**

###### CAUSE :

The cutters (hammers) touch the ground during operation.

###### INTERVENTION :

Reset the machine's correct height from the ground.

### 4.7.3. Replacement of the belts

Alce shredder 1600-1950-2300-2500-2700-3200 - Super Alce 2500-2700-3200

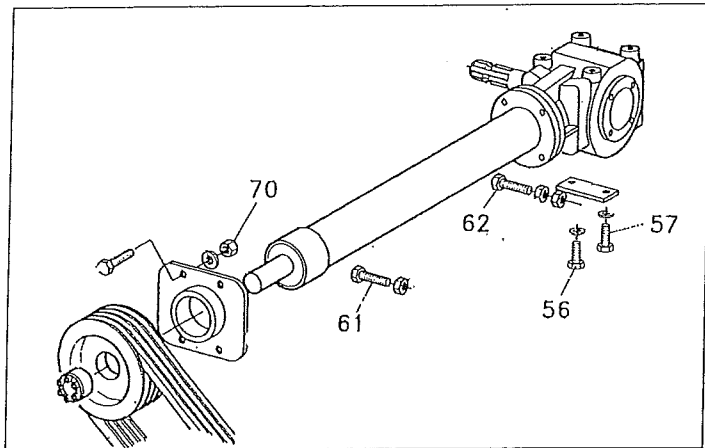

Carry out the following operations to replace the belts:

- a) Remove the belts' safety guard
- b) Loosen the 4 nuts pos. 70 and the 4 screws pos. 56-57
- c) Loosen the adjustment screws pos. 61 and 62. In this manner, a movement of the pulley is obtained and consequently the tension of the belts is reduced.
- d) Slide the belts from their respective pulley's races and replace them with new ones. Carefully check that the new belts are the same as the old ones, both as regards the length as well as the type. FALC s.r.l. installs toothed belts type SPB on standard series machines.
- e) To place the belts in tension again, reset the adjustment bolts previously loosened.

**The screws must be adjusted in such a way that the upper pulley remains parallel and on the same plane as the lower pulley. If the upper pulley is in an incorrect position with respect to the lower one, the belts do not transmit the right power and will hence have a shorter life.**

- f) Check the tension of the belts
- g) Tighten the fixing screws previously loosened
- h) Remount the belts' safety guard.

**Super Alce shredder 3200DT-4000-4200-4800**

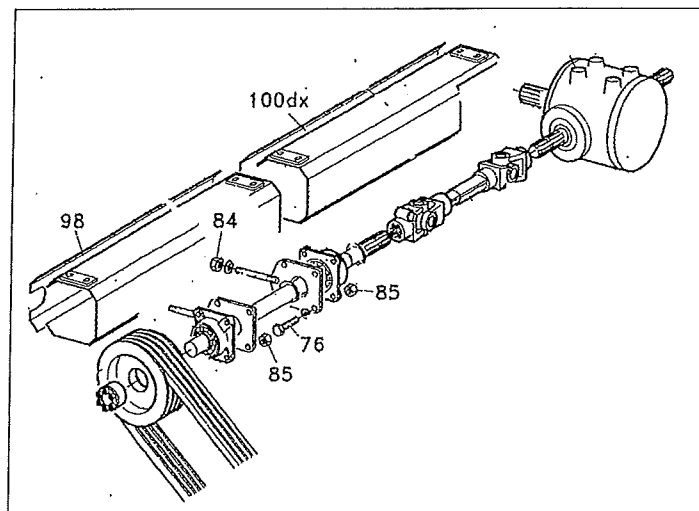

To replace the belts follow the following operation:

- a) Remove the belt safety guard and the upper transmission shaft protection pos.98 – 99 left – 100 right..
- b) Loosen the screws and bolts pos.76-85 which block the 2 upper transmission shaft supports.
- c) Loosen the adjustment nuts pos.84. In this manner, a movement of the pulley is obtained and consequently the tension of the belts is reduced.
- d) Slide the belts from their respective pulley's races and replace them with new ones. Carefully check that the new belts are the same as the old ones, both as regards the length as well as the type. FALC s.r.l, installs toothed belts type SPB on standard series machines.
- e) To place the belts in tension again, reset the adjustment bolts previously loosened.  
**The screws must be adjusted in such a way that the upper pulley remains parallel and on the same plane as the lower pulley. If the upper pulley is in an incorrect position with respect to the lower one, the belts do not transmit the right power and will hence have a shorter life.**
- f) Check the tension of the belts
- g) Tighten the fixing screws previously loosened
- h) Remount the belts' safety guard and the upper transmission shaft protection

### Kronos shredder

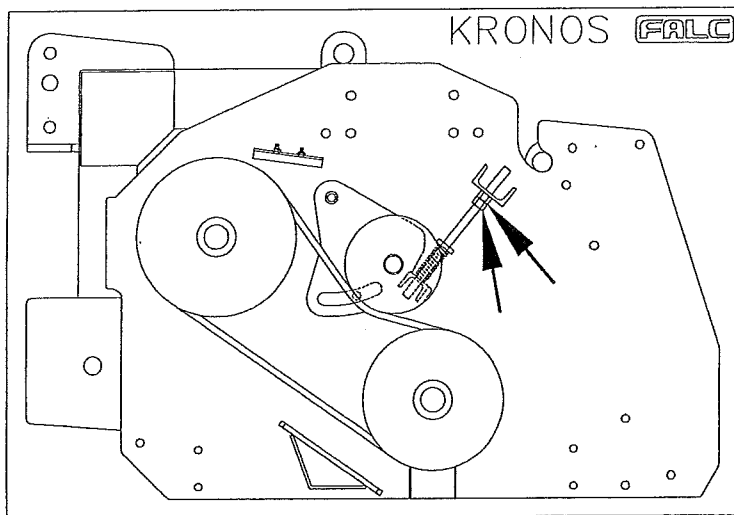

Carry out the following operations to replace the belts:

- a) Open the belts' safety guard.
- b) Loosen the 4 nuts of the rivetted bar.
- c) In this manner, a movement of the idle pulley is obtained and consequently the tension of the belts is reduced.
- d) Slide the belts from their respective pulley's races and replace them with new ones. Carefully check that the new belts are the same as the old ones, both as regards the length as well as the type. FALC s.r.l, installs toothed belts type SPB on standard series machines.
- e) To place the belts in tension again, turn the nuts of the rivetted bar previously loosened.
- f) Check the tension of the belts
- g) Tighten the fixing bolts previously loosened
- h) Close the belts' safety guard.

#### 4.7.4. ASSEMBLING AND DISMANTLING THE PULLEYS

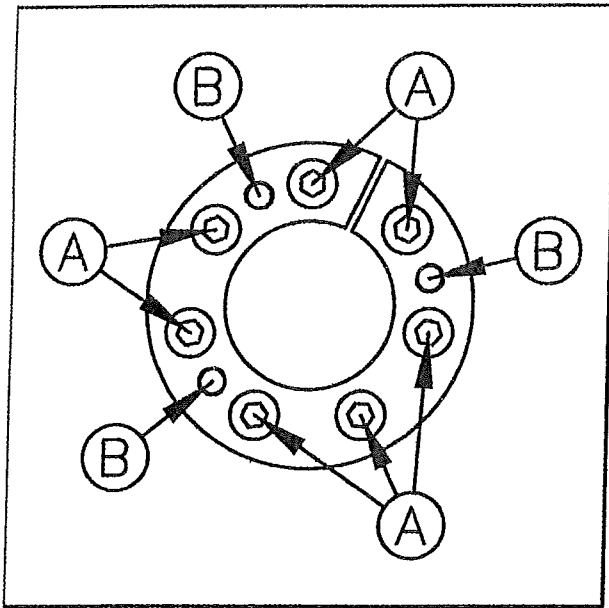

The pulleys are fixed on the relative shafts by means of a coupling similar to that shown in the diagram above.

- a) To dismantle the pulleys adhere to the following steps:
    - Loosen the bolts (A) with the relative key
    - Remove "x" no. of bolts (A) and insert them into the threaded holes (B) tightening in a uniform manner
    - After a few turns of the bolts the pulley can easily be slipped out from the shaft
  - b) To assemble the pulleys adhere to the following steps:
    - Insert the coupling in the pulley's hole
    - Connect it all to the shaft ensuring that the pulley is in the right position
    - Tighten in a uniform manner the bolts (A) with the relative key
- ATTENTION :** Tightening moment = 40 N/m (4,1 kg/m)

## 5. GUARANTEE

- a) The guarantee is valid 1 year from the date of the delivery. The company is committed to replacing parts which present material or manufacturing defects in as short a time as possible. The manpower necessary for replacing parts is excluded from the guarantee. Any transport or forwarding expenses are excluded from the guarantee.
- b) The guarantee ceases if breakage is the result of forza maggiore, incorrect use of the machine or any erroneous action carried out by the purchaser, employees or third parties. Repairs, replacements, modifications carried out by the purchaser or for the purchaser without the authorisation of the manufacturer are included in these actions. Incorrect use of the machine is understood to mean actions which are not listed in the user norms listed in this instruction manual.
- c) Parts which due to their very nature or use are subject to inevitable deterioration or wear are excluded from this guarantee.
- d) The bearings and oil retainers are not under guarantee.
- e) The cardan shaft is not under guarantee.
- f) The following standards are valid for the parts for which a warranty is requested:
  - the piece to be replaced must be returned to the manufacturer the moment in which a request is made for a new piece.
  - the spare parts are always invoiced when forwarded.
  - only examination by the manufacturer's technicians can result in the guarantee being upheld and, therefore, accredited.

## 6. NORMS TO BE FOLLOWED FOR CORRECTLY ORDERING SPARE PARTS

In order to quickly deal with the orders relative to spare parts it is necessary to specify :

- a) Type of machine, Model, Series number.  
(E.g. Super Alce 3200 series' number. XXXXXX)
- b) Number of the spare parts table in which the piece in question is to be located, identification number, piece code.  
(E.g. Table no. YY ; Item no. JJ ; Code KKKKKK)
- c) Exact denomination of the item.
- d) Quantity of pieces requested.
- e) Instructions for the forwarding.  
(rail, postal package, courier, etc.)
- f) The minimum delivery time for the parts requested is 3 days from the date of receiving the order.

**If any part of this instruction manual should result insufficiently clear, we ask you to kindly contact your closest authorised dealer or contact us directly at our technical and commercial departments.**

This handbook or any part of it cannot be reproduced, copied or published without prior written authorization of FALC.

FALC reserves the right to modify the here described specifications at any time without committing itself to update this handbook every time.

## 7) SAFETY PICTOGRAMS

All the safety pictograms applied to Falc's machines, are based on norms ISO 11/684. The adhesive labels adopted are 168 x 88 mm and are divided in two equal parts. The left part contains within the triangular danger symbol the graphic description of the symbol itself.

e.g. Attention - Danger of flying objects.

The right part shows how to avoid the risk.

e.g. Maintain a safety distance.

Together, these 2 graphics synthesise the full message which is intended to be transmitted to all those which for various reasons are in direct contact or nearby a Falc-produced machine.

(see enclosure C of the norm)

The graphical message is hence directed to the machine operators as well as all those that enter within the working radius of the machine.

**The operator is obliged to carefully read the machine's instruction manual in order to understand its correct operation and to have a comprehensive explanation of the safety pictograms**

The complete list of all the pictograms which are applied to Falc-produced machines is reported hereafter with the relative explanation on the side.

### Label no.1

**ATTENTION:** Read the instruction manual before using the machine.

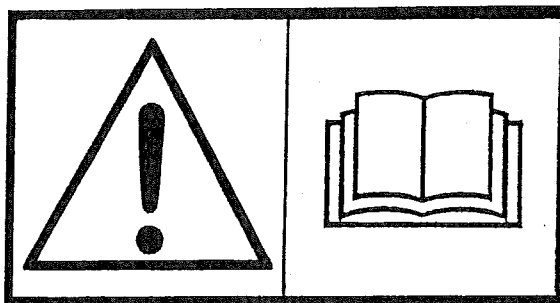

FALC FAENZA (RA) - ITALY - TEL. 0546/29050 - FAX 0546/663986 1

### Label no.2

**ATTENTION:** Danger of hand and fingers collision with movements in alternate rotation.

Keep the safety distance.

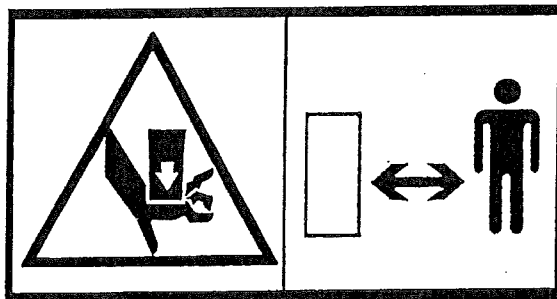

FALC FAENZA (RA) - ITALY - TEL. 0546/29050 - FAX 0546/550866 2

### Label no.3

**ATTENTION:** Danger of foot collision with movements in alternate rotation.

Keep the safety distance.

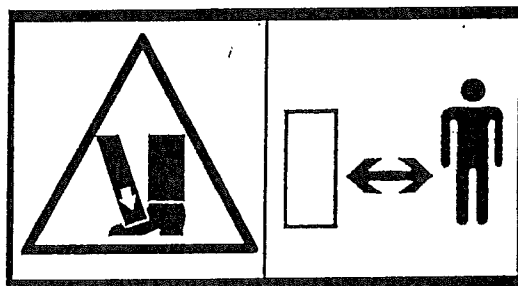

FALC FAENZA (RA) - ITALY - TEL. 0546/29050 - FAX 0546/550866 3

**Label no.4**

**ATTENTION:** Danger for feet due to rotating cutters with horizontal rotating axis. Keep the safety distance.

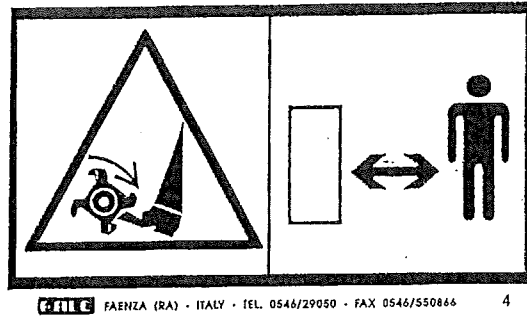

**Label no.5**

**ATTENTION:** Danger due to machine component that can be lifted from the ground. Keep the safety distance.

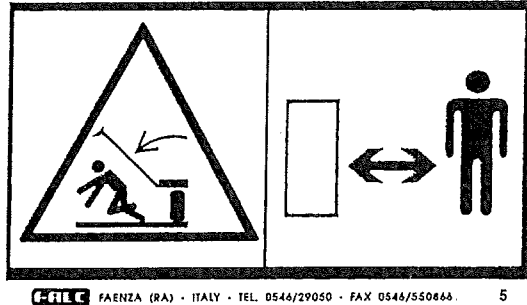

**Label no.6**

**ATTENTION:** Danger of cutting due to moving parts. Wait until all moving components are completely still before approaching the machine.

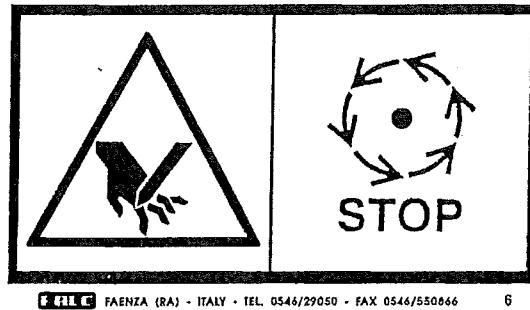

**Label no.7**

**ATTENTION:** Danger due to flying objects. Keep the safety distance.

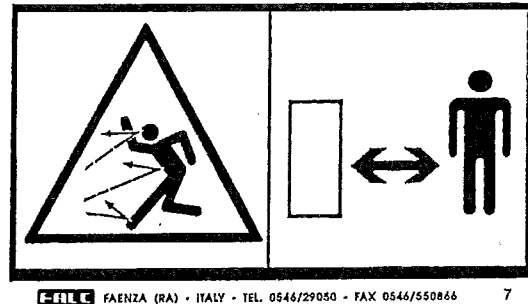

**Label no.8**

**ATTENTION:** Danger due to hot surfaces. Keep the safety distance.

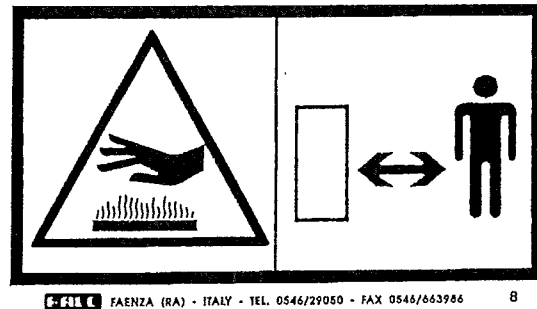



**Label no.9**

**ATTENTION:** Danger of hand and finger cutting.  
Keep the safety distance.

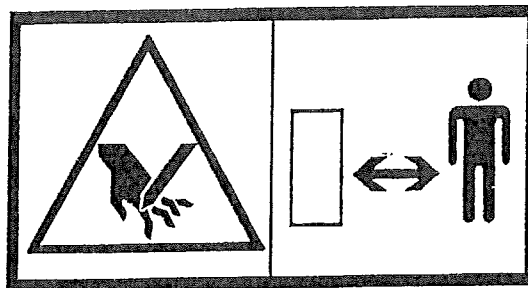

FALC FAENZA (RA) - ITALY - TEL. 0546/29050 - FAX 0546/663986 9

**Label no.10**

**ATTENTION:** Danger of feet cutting.  
Maintain the safety distance.

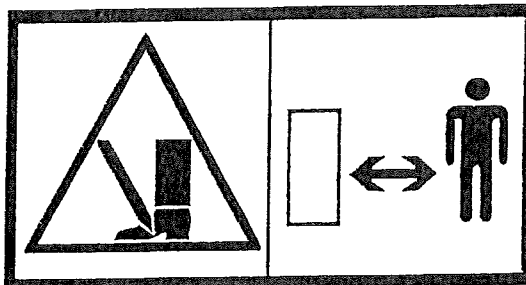

FALC FAENZA (RA) - ITALY - TEL. 0546/29050 - FAX 0546/663986 10

**Label no.11**

**ATTENTION:** Danger of rotating movements.  
Do not open or remove the safety guards of the rotating shafts while the machine is in operation.

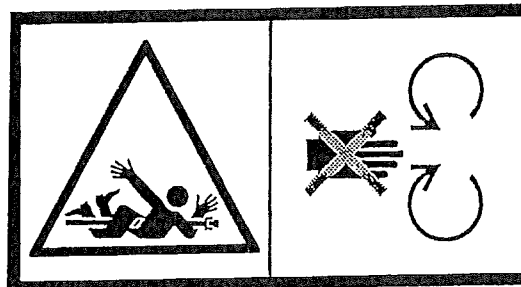

FALC FAENZA (RA) - ITALY - TEL. 0546/29050 - FAX 0546/663986 11

**Label no.12**

**ATTENTION:** Danger due to loads lifted from the ground.  
Keep the safety distance.



FALC FAENZA (RA) - ITALY  
TEL 0546/29050 FAX 663986 12

## Italiano: Istruzione per il montaggio del cardano

<p>Prima di montare il cardano, leggere attentamente il Libretto fornito dal costruttore del cardano stesso. La Ditta Falc Srl declina ogni responsabilità per operazioni effettuate sul cardano senza seguire le Istruzioni specifiche fornite dal costruttore del cardano stesso.</p>	<p>Prima di iniziare a lavorare, si raccomanda di verificare la lunghezza del cardano: se è LUNGO, alzando o abbassando la macchina, le 2 parti telescopiche si accoppieranno completamente creando pressione sulle crociere e sulle forcelle; se è CORTO, alzando o abbassando la macchina, le 2 parti telescopiche si sfileranno troppo.</p>	<p>Le macchine agricole portate sono collegate direttamente al trattore e posizionate mediante attacco a tre punti. Generalmente con attrezzo in lavoro (a) si ha la configurazione di minore lunghezza dell'albero ed angoli di snodo sensibilmente uguali. Ad attrezzo sollevato (b) si ha la massima estensione dell'albero, l'aumento e la diversificazione degli angoli di snodo. Durante il sollevamento è <b>INDISPENSABILE</b> interrompere la rotazione del cardano.</p>
---	--	---

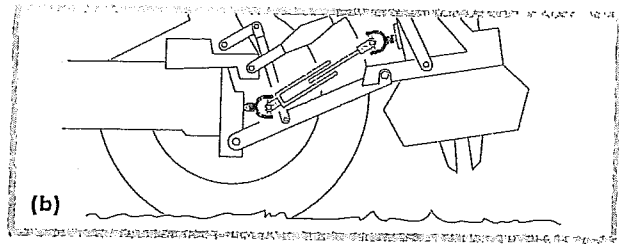
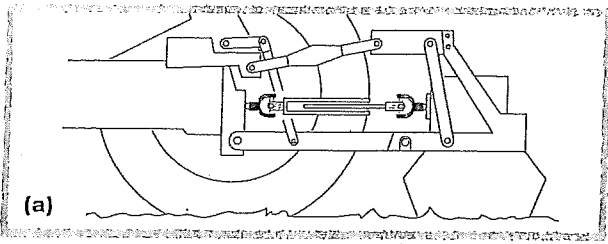

## Français: Instructions pour le montage de l'arbre à cardan

<p>Avant de monter le cardan, lire attentivement le Livret fourni par le fabricant du cardan lui-même. L'entreprise Falc Srl décline toute responsabilité pour toute opération effectuée sur le cardan sans avoir suivi les instructions spécifiques fournies par le fabricant de ce cardan.</p>	<p>Avant de commencer à travailler, nous recommandons de vérifier la longueur du cardan : s'il est LONG, en relevant ou en baissant la machine, les deux parties télescopiques vont s'accoupler complètement en exerçant une pression sur les tourillons et les fourchettes ; s'il est COURT, en relevant ou en baissant la machine, les 2 parties télescopiques risquent de se désenfiler totalement.</p>	<p>Les machines agricoles portées sont connectées directement au tracteur avec trois points d'enclenchement différents. Avec l'outil en fonction (a) la configuration du cardan est de longueur minimum et les angles d'articulation sont similaires. Lorsque l'outil est soulevé (b), l'extension du cardan est au maximum et l'augmentation et la diversification des angles d'articulation. Pendant le soulèvement il est <b>INDISPENSABLE</b> d'interrompre la rotation du cardan.</p>
--	--	--

## English: Instructions for the assembling of the cardan shaft

<p>Before mounting the cardan shaft, carefully read the booklet supplied by the Manufacturer. Falc Srl declines all responsibility for operations carried out on the cardan shaft if the specific instructions supplied by the Manufacturer are not followed.</p>	<p>Before starting work, it is advised to check the length of the cardan shaft: if it is LONG, by raising or lowering the machine, the 2 telescopic parts will couple completely, creating pressure on the cross and on the forks; if it is SHORT, by raising or lowering the machine, the 2 telescopic parts will slide apart too much.</p>	<p>The agricultural machinery lead is connected directly to the tractor and positioned using a three-point attachment. Generally, when the equipment is functioning (a) the shorter length of the shaft with equal articulation angles is present. With the equipment raised (b) there is maximum extension of the shaft, increase and diversification of the articulation angles. During lifting it is <b>INDISPENSABLE</b> to interrupt rotation of the cardan shaft.</p>
---	--	---

## Deutsch: Bedingungen für die Gelenkwellenanbau

<p>Bevor Sie die Kardanwelle montieren, ist das vom Hersteller der Kardanwelle gelieferte Handbuch aufmerksam durchzulesen.</p> <p>Falc Srl haftet nicht für an der Kardanwelle durchgeführte Arbeiten, bei denen die spezifischen Anweisungen des Herstellers der Kardanwelle nicht eingehalten wurden.</p>	<p>Vor dem Beginn der Arbeiten ist die Länge der Kardanwelle zu überprüfen. Falls die Kardanwelle LANG ist, kuppeln die beiden Teleskopteile bei Heben oder Senken vollständig ein und drücken auf das Gelenkkreuz und das Gabelgelenk.</p> <p>Falls die Kardanwelle KURZ ist, fahren die beiden Teleskopteile bei Heben oder Senken zu sehr aus.</p>	<p>Die Anbau-Landmaschinen werden direkt an den Traktor angeschlossen und mit einem Dreipunktanschluss positioniert.</p> <p>Im Allgemeinen sind im Fahrzustand der Maschine (a) die Welle kürzer und die Gelenkwinkel annähernd gleich. Bei gehobener Maschine (b) ist die Welle maximal ausgefahren; die Gelenkwinkel sind größer und unterscheiden sich voneinander. Während des Hubs MUSS die Rotation der Welle unterbrochen werden.</p>
--	---	--

## Español: Instrucciones para el montaje de la cardan

<p>Antes de montar el cardan, leer detenidamente el Manual suministrado por el fabricante de éste.</p> <p>La empresa Falc Srl se exime de cualquier responsabilidad frente a operaciones que puedan efectuarse en el cardan sin cumplimiento de las instrucciones específicas dictadas por el fabricante del mismo.</p>	<p>Antes de iniciar a trabajar, se recomienda comprobar que la longitud del cardan sea la adecuada: Si es demasiado LARGO, al alzar o descender la máquina sus 2 partes telescópicas se acoplarán completamente, creando presión en las crucetas y en las horquillas.</p> <p>Si es demasiado CORTO, al alzar o descender la máquina sus 2 partes telescópicas se extenderán excesivamente.</p>	<p>Las máquinas agrícolas utilizadas están directamente unidas al tractor por medio de un enganche de tres puntos. Generalmente, cuando el equipo está en posición de trabajo (a) se obtiene una configuración con una menor longitud del árbol y con ángulos de articulación muy parecidos. Con el equipo en posición alzada (b) se obtiene la extensión máxima del árbol, con un aumento de los ángulos de articulación, que ahora serán distintos entre sí. Durante la elevación es <b>INDISPENSABLE</b> interrumpir la rotación del cardan.</p>
---	--	---





