

www.falc.eu
e-mail: info@falc.eu

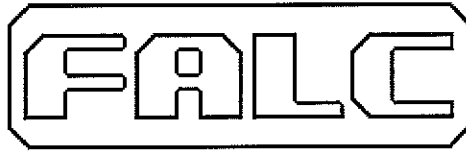

via Proventa n.41 – 48018 Faenza (Ra) - ITALY -
☎ +39 0546 29050
Fax +39 0546 663986

Catalogo Ricambi / Spare Parts Book

Modello / Model:

Fresa / Rotary Tiller D

Matricola / Serial number:

.....

LATO DESTRO
RIGHT SIDE
CÔTÉ DROITE
RECHTS

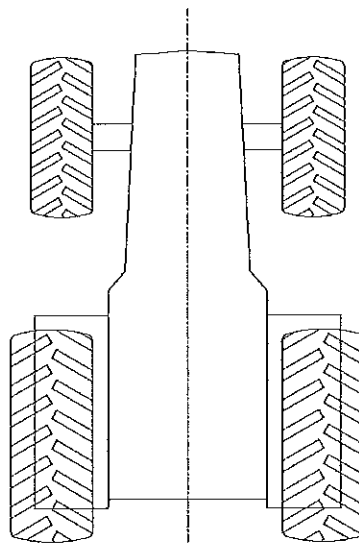

LATO SINISTRO
LEFT SIDE
CÔTÉ GAUCHE
LINKS



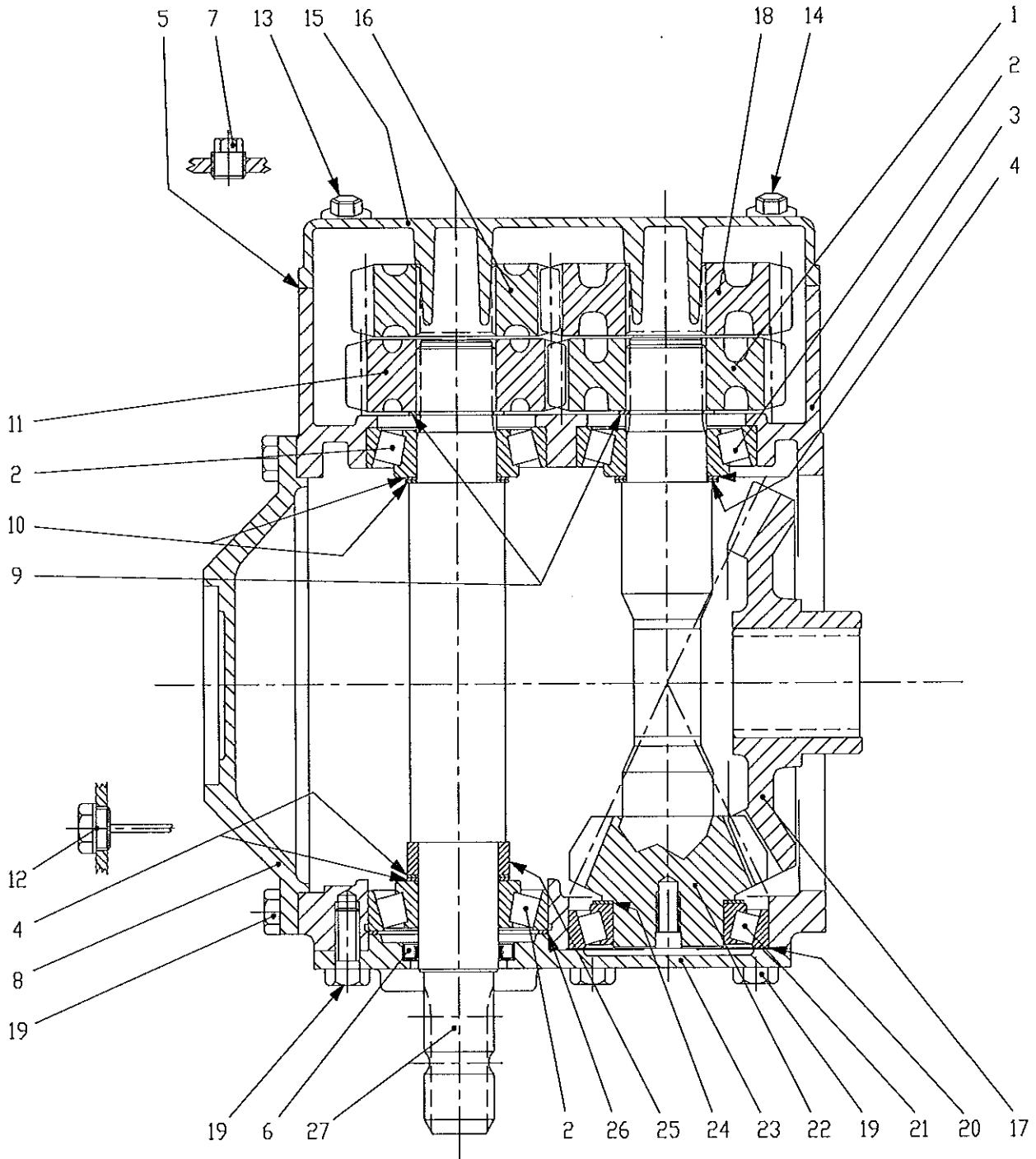

D ROTARY TILLER
GEARBOX MZ-2A

TAV.573

FRESA D
RIDUTTORE MZ-2A



Falc	Tavola Ricambi Parts Book	Riduttore MZ2A Gearbox MZ2A
pag.1	n.573 – 03/2008	FRESA D 1600-1800-2100-2300-2500 D 1600-1800-2100-2300-2500 rotary tiller

Pos. Fig.	Codice Item #	Descrizione Description	
	88.90.08	Riduttore MZ2A completo 4 velocità (con corona) – SENZA PROLUNGA Cod. Comer 9.702.511.00	Gearbox MZ2A with 4 speeds (with crown) – WITHOUT JACKSHAFT Item # Comer 9.702.511.00
1	0.702.5010.00	Ingranaggio cambio z=21	Change gear z=21
2	06.1.024	Cuscinetto a rulli conici 30308	Taper roller bearing 30308
3	0.702.0300.06	Scatola	Gearbox
4	0.244.7500.00	Spessore di registro 40.3x51.5	Shim 40.3x51.5
5	0.702.7201.00	Guarnizione cambio	Change gasket
6	07.0.032	Paraolio 40x56x8	Oil seal 40x56x8
7	8.6.5.00006	Tappo conico esagono esterno 3/8" gas	Conical plug external hexagon 3/8"
8	0.702.1332.01	Coperchio chiuso	Cover
9	05.0.012	Seeger per alberi Ø40x1.75 UNI 7435	Snap ring for shafts Ø40x1.75 UNI 7435
10	0.244.7510.00	Spessore di registro 51.3x40.3x1.0	Shim 51.3x40.3x1.0
11	0.702.5009.00	Ingranaggio cambio z=19	Change gear z=19
12	0.703.7106.00	Tappo carico livello olio TCAS- 2215	Oil plug TCAS-2215
13	01.0.125	Vite TE M8 L=40 tf UNI 5739	Screw TE M8 L=40 tf UNI 5739
14	01.0.103	Vite TE M8 L=25 tf UNI 5739	Screw TE M8 L=25 tf UNI 5739
15	1.702.1401.00	Coperchio cambio	Cover
16	0.702.5008.00	Ingranaggio cambio z=18	Change gear z=18
17	0.702.6008.00	Corona conica z=29 m=6.75	Crown wheel z=29 m=6.75
18	0.702.5011.00	Ingranaggio cambio z=23	Change gear z=23
19	01.0.204	Vite TE M12 L=30 tf UNI 5739	Screw TE M12 L=30 tf UNI 5739
20	0.703.7500.00	Spessore di registro 85.3x99.7	Shim 85.3x99.7
21	06.1.002	Cuscinetto a rulli conici 30211	Taper roller bearing 30211
22	0.702.6007.00	Pignone conico z=14 m=6.75	Pinion z=14 m=6.75
23	0.702.1318.00	Coperchio	Cap
24	0.252.7500.00	Spessore di registro 45.3x65.3	Shim 45.3x65.3
25	0.710.7106.00	Distanziale 40.1x51x16.5	Spacer 40.1x51x16.5
26	0.702.7500.00	Spessore di registro 80.3x89.7	Shim 80.3x89.7
27	0.702.2002.00	Albero	Shaft

FRESA D DROTARY TILLER

TAV.645

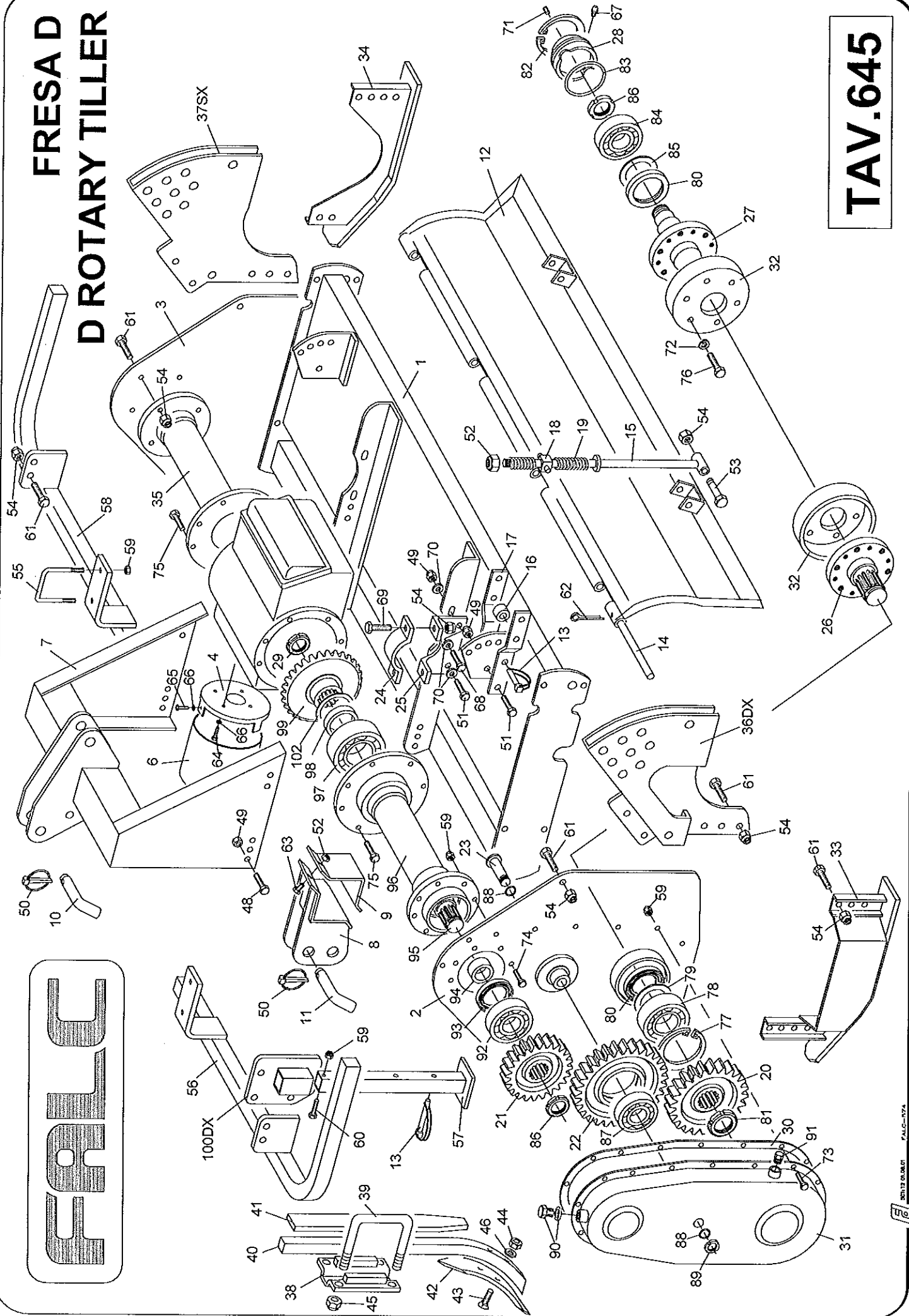

Falc	Tavola Ricambi Parts Book	Telaio e Trasmissione Frame and Drive
pag.1	n.645 – 03/2008	FRESA D 1600-1800-2100-2300-2500 D 1600-1800-2100-2300-2500 rotary tiller

Pos. Fig.	Codice Item #	Descrizione Description	
	88.90.09	Riduttore completo per D4 1600	Complete gearbox for D4 1600
	88.90.10	Riduttore completo per D4 1800	Complete gearbox for D4 1800
	88.90.11	Riduttore completo per D4 2100	Complete gearbox for D4 2100
	88.90.12	Riduttore completo per D4 2300	Complete gearbox for D4 2300
	88.90.13	Riduttore completo per D4 2500	Complete gearbox for D4 2500
1	88.60.60	Telaio 1600	Frame 1600
	88.60.00	Telaio 1800	Frame 1800
	88.60.01	Telaio 2100	Frame 2100
	88.60.02	Telaio 2300	Frame 2300
	88.60.03	Telaio 2500	Frame 2500
2	88.60.24	Flangia lato trasmissione	Flange transmission side
3	88.60.25	Flangia opposto trasmissione	Flange opposite transmission
4	88.60.33	Supporto protezione pto	Support PTO guarding
6	88.60.34	Protezione pto	PTO guarding
7	88.60.26	Attacco a 3 punti	3 point linkage
8	88.60.27	Attacco a 3 punti inferiore	Bottom 3 point linkage
9	88.60.28	Cavallotto	U bolt
10	53.10.53	Spina superiore	Top pin
11	25.02.66	Spina inferiore	Bottom pin
12	88.60.61	Carter mobile posteriore 1600	Rear movable case 1600
	88.60.04	Carter mobile posteriore 1800	Rear movable case 1800
	88.60.05	Carter mobile posteriore 2100	Rear movable case 2100
	88.60.06	Carter mobile posteriore 2300	Rear movable case 2300
	88.60.07	Carter mobile posteriore 2500	Rear movable case 2500
13	05.5.003	Spina di sicurezza art.1370	Safety pin art. 1370
14	88.60.62	Perno carter mobile posteriore 1600	Rear movable case pin 1600
	88.60.29	Perno carter mobile posteriore 1800	Rear movable case pin 1800
	88.60.30	Perno carter mobile posteriore 2100	Rear movable case pin 2100
	88.60.31	Perno carter mobile posteriore 2300	Rear movable case pin 2300
	88.60.32	Perno carter mobile posteriore 2500	Rear movable case pin 2500
15	88.60.19	Asta ammortizzatore carter mobile posteriore	Shock absorber rod
16	88.60.20	Distanziale bracci ammortizzatore carter	Shock absorber arms spacer
17	88.60.21	Braccio ammortizzatore	Shock absorber arm
18	88.60.22	Boccola snodata asta ammortizzatore	Bush for rod
19	88.60.23	Molla attacco carter	Spring for case linkage
20	88.60.35	Ingranaggio inferiore Z=29	Bottom gear Z=29
21	88.60.36	Ingranaggio superiore Z=24	Top gear Z=24
22	88.60.37	Ingranaggio centrale Z=38	Central gear Z=38
23	88.60.38	Perno ingranaggio centrale	Pin for central gear
24	88.60.46	Cavallotto superiore	Top U bolt
25	88.60.47	Cavallotto inferiore	Bottom U bolt
26	88.60.15	Mozzo rotore lato trasmissione	Rotor hub transmission side
27	88.60.16	Mozzo rotore lato opposto trasmissione	Rotor hub opposite transmission
28	88.60.18	Coperchio opposto trasmissione	Cap opposite transmission
29	03.1.008	Ghiera autobloccante GUK M45x1.5 h=12,1	Selflocking GUK ring nut M45x1.5 h=12,1
30	88.60.42	Guarnizione carter	Case gasket
31	88.60.43	Carter	Case

Falc	Tavola Ricambi Parts Book	Telaio e Trasmissione Frame and Drive
pag.2	n.645 – 03/2008	FRESA D 1600-1800-2100-2300-2500 D 1600-1800-2100-2300-2500 rotary tiller

Pos. Fig.	Codice Item #	Descrizione Description
--------------	------------------	----------------------------

32	88.60.17	Coperchietto di protezione	Guarding cap
33	88.60.44	Slitta lato trasmissione	Skid transmission side
34	88.60.45	Slitta lato opposto trasmissione	Skid opposite transmission
35	88.60.63	Prolunga opposta trasmissione 1600	Tube opposite transmission 1600
	88.60.11	Prolunga opposta trasmissione 1800	Tube opposite transmission 1800
	88.60.12	Prolunga opposta trasmissione 2100	Tube opposite transmission 2100
	88.60.13	Prolunga opposta trasmissione 2300	Tube opposite transmission 2300
	88.60.14	Prolunga opposta trasmissione 2500	Tube opposite transmission 2500
36	88.60.40	Flangia laterale dx regolazione rullo	Rh flange for roller adjustment
37	88.60.41	Flangia laterale sx regolazione rullo	Lh flange for roller adjustment
38	51.90.01	Staffa per tubo 80x80	Bracket for tube 80x80
39	51.90.02	Cavallotto per tubo 80x80	U bolt for tube 80x80
40	51.90.00	Braccio diritto L=600	Straight arm L=750
41	51.90.03	Rinforzo posteriore dente	Rear reinforcement tine
42	24.40.40	Vomerino	Share
43	01.5.401	Vite TPSQST M12 L=60 UNI 6104	Screw TPSQST M12 L=60 UNI 6104
44	02.0.404	Dado M12 h=10 UNI 5588	Nut M12 h=10 UNI 5588
45	02.2.006	Dado autobloccante M18 h=21 UNI 7473	Selflocking nut M18 h=21 UNI 7473
46	04.0.004	Grower serie pesante d 12	Grower d 12
48	01.1.102	Vite TE M12x1,25 L=30 tf UNI 5740	Screw TE M12x1,25 L=30 tf UNI 5740
49	02.3.002	Dado autobloccante M12x1,25 h=14.8 UNI 7473	Selflocking nut M12x1,25 h=14.8 UNI 7473
50	05.3.402	Spina a scatto d 10 art.104	Release pin d 10 art.104
51	01.1.107	Vite TE M12x1,25 L=45 pf UNI 5738	Screw TE M12x1,25 L=45 pf UNI 5738
52	02.3.004	Dado autobloccante M16x1,5 h=18 UNI 7473	Selflocking nut M16x1,5 h=18 UNI 7473
53	01.1.174	Vite TE M14x1,5 L=80 pf UNI 5738	Screw TE M14x1,5 L=80 pf UNI 5738
54	02.3.003	Dado autobloccante M14x1,5 h=16,6 UNI 7473	Selflocking nut M14x1,5 h=16,6 UNI 7473
55	88.60.39	Cavallotto fissaggio protezioni CE	U bolt for CE guarding
56	70.02.40	Protezione CE lato trasmissione D 1600	CE guarding transmission side D 1600
	70.02.12	Protezione CE lato trasmissione D 1800	CE guarding transmission side D 1800
	70.02.13	Protezione CE lato trasmissione D 2100	CE guarding transmission side D 2100
	70.02.14	Protezione CE lato trasmissione D 2300	CE guarding transmission side D 2300
	70.02.15	Protezione CE lato trasmissione D 2500	CE guarding transmission side D 2500
57	70.02.20	Piede di appoggio	Parking stand
58	70.02.41	Protezione CE lato opp. trasm. D 1600	CE guarding opposite transmission D 1600
	70.02.16	Protezione CE lato opp. trasm. D 1800	CE guarding opposite transmission D 1800
	70.02.17	Protezione CE lato opp. trasm. D 2100	CE guarding opposite transmission D 2100
	70.02.18	Protezione CE lato opp. trasm. D 2300	CE guarding opposite transmission D 2300
	70.02.19	Protezione CE lato opp. trasm. D 2500	CE guarding opposite transmission D 2500
59	02.2.002	Dado autobloccante M10 h=12.3 UNI 7473	Selflocking nut M10 h=12.3 UNI 7473
60	01.0.190	Vite TE M10 L=55 pf UNI 5737	Screw TE M10 L=55 pf UNI 5737
61	01.1.152	Vite TE M14x1,5 L=35 tf UNI 5740	Screw TE M14x1,5 L=35 tf UNI 5740
62	05.3.012	Copiglia d 5 L=40 UNI 1336	Split pin d 5 L=40 UNI 1336
63	01.1.206	Vite TE M16x1,5 L=50 tf UNI 5740	Screw TE M16x1,5 L=50 tf UNI 5740
64	01.0.101	Vite TE M8 L=16 tf UNI 5739	Screw TE M8 L=16 tf UNI 5739
65	01.0.134	Vite TE M8 L=20 tf UNI 5739 zincata	Screw TE M8 L=20 tf UNI 5739 galvanized
66	04.1.226	Rosetta d 8 9x24x2 UNI 6593 cat.C zincata	Washer d 8 9x24x2 UNI 6593 cat.C galv.

Falc	Tavola Ricambi Parts Book	Telaio e Trasmissione Frame and Drive
pag.3	n.645 – 03/2008	FRESA D 1600-1800-2100-2300-2500 D 1600-1800-2100-2300-2500 rotary tiller

Pos. Fig.	Codice Item #	Descrizione Description	
67	09.2.504	Ingrassatore diritto a spillo M10	Greaser M10
68	01.1.104	Vite TE M12x1,25 L=35 tf UNI 5740	Screw TE M12x1,25 L=35 tf UNI 5740
69	01.1.159	Vite TE M14x1,5 L=100 pf UNI 5738	Screw TE M14x1,5 L=100 pf UNI 5738
70	04.1.232	Rosetta d 12 14x36x3 UNI 6593 cat.C	Washer d 12 14x36x3 UNI 6593 cat.C
71	01.5.110	Grano M8 L=20 UNI 5923	Grub screw M8 L=20 UNI 5923
72	04.0.005	Grower serie pesante d 14	Grower d 14
73	01.0.153	Vite TE M10 L=25 tf UNI 5739	Screw TE M10 L=25 tf UNI 5739
74	01.0.158	Vite TE M10 L=35 tf UNI 5739	Screw TE M10 L=35 tf UNI 5739
75	01.0.204	Vite TE M12 L=30 tf UNI 5739	Screw TE M12 L=30 tf UNI 5739
76	26.00.01	Vite TE M14x1,5 L=33 pf classe 10.9	Screw TE M14x1,5 L=33 pf classe 10.9
77	05.1.006	Seeger per interni d 130x4 UNI 7437	Snap ring d 130x4 UNI 7437
78	06.2.001	Cuscinetto 21312	Bearing 21312
79	88.60.10	Anello di tenuta Nilos 6312 AV	Seal ring Nilos 6312 AV
80	07.0.049	Paraolio 70x90x10	Oil seal 70x90x10
81	03.1.012	Ghiera autobloccante GUP M55x2 h=18,5	Selflocking GUP ring nut M55x2 h=18,5
82	05.1.004	Seeger per interni d 110x4 UNI 7437	Snap ring d 110x4 UNI 7437
83	07.1.042	Guarnizione OR 189	Gasket OR 189
84	06.0.022	Cuscinetto 6310	Bearing 6310
85	88.60.09	Anello di tenuta Nilos 6310 AV	Seal ring Nilos 6310 AV
86	03.1.009	Ghiera autobloccante GUP M45x1,5 h=16,5	Selflocking GUP ring nut M45x1,5 h=16,5
87	06.0.501	Cuscinetto 3309	Bearing 3309
88	07.1.050	Guarnizione OR 4100	Gasket OR 4100
89	03.1.016	Ghiera autobloccante GUK M25x1,5 h=10,3	Selflocking GUK ring nut M25x1,5 h=10,3
90	09.2.011	Tappo olio TS 36 ½" gas	Oil plug TS 36 ½" gas
91	09.2.029	Tappo conico con esagono esterno ½" gas	Conical plug 1/2" gas
92	06.2.507	Cuscinetto NU310	Bearing NU310
93	07.0.165	Paraolio 65x100x12	Oil seal 65x100x12
94	88.60.08	Distanziale per paraolio	Spacer for oil seal
95	88.80.54	Albero prolunga D 1600	Shaft D 1600
	88.80.21	Albero prolunga D 1800	Shaft D 1800
	88.80.22	Albero prolunga D 2100	Shaft D 2100
	88.80.23	Albero prolunga D 2300	Shaft D 2300
	88.80.24	Albero prolunga D 2500	Shaft D 2500
96	88.80.55	Prolunga D 1600	Jackshaft D 1600
	88.80.25	Prolunga D 1800	Jackshaft D 1800
	88.80.26	Prolunga D 2100	Jackshaft D 2100
	88.80.27	Prolunga D 2300	Jackshaft D 2300
	88.80.28	Prolunga D 2500	Jackshaft D 2500
97	06.1.023	Cuscinetto 30214	Bearing 30214
98	88.80.29	Distanziale	Spacer
99		Vedi Tavola Ricambi 573 pos.17	See Tav. 573 fig. 17
100	70.02.21	Supporto piede di appoggio	Support for parking stand
102	0.249.7503	Spessore di registro 70,3x89,7x0,3	Shim 70,3x89,7x0,3
	0.249.7504	Spessore di registro 70,3x89,7x0,4	Shim 70,3x89,7x0,4
	0.249.7505	Spessore di registro 70,3x89,7x0,5	Shim 70,3x89,7x0,5

FALC

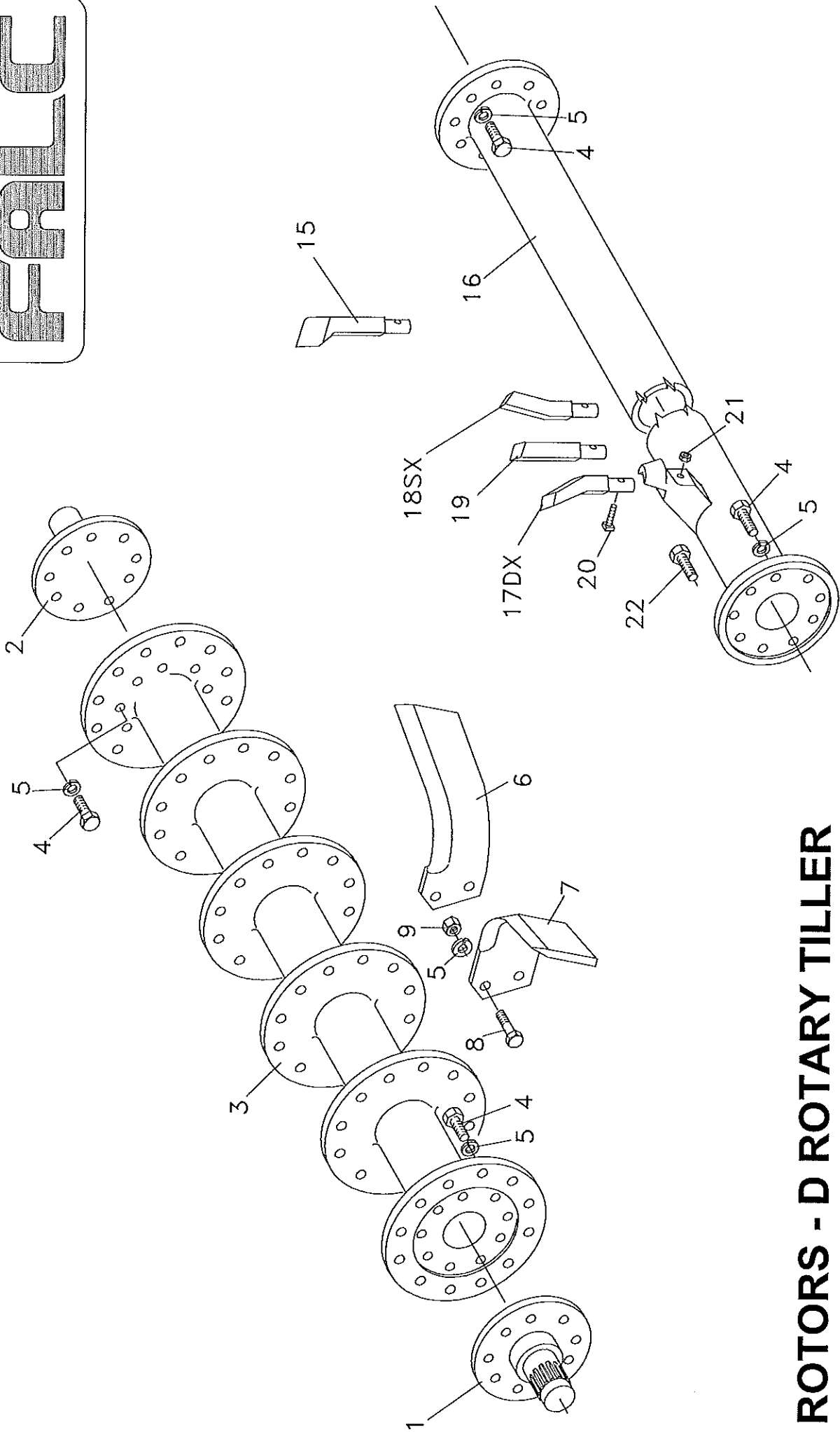

ROTORS - D ROTARY TILLER
ROTORI - FRESA D

TAV.646

Falc	Tavola Ricambi Parts Book	Rotori Rotors
pag.1	n.646 – 09/2011	FRESA D 1600-1800-2100-2300-2500 D 1600-1800-1800-2100-2300-2500 rotary tiller

Pos. Fig.	Codice Item #	Descrizione Description	
1		Vedi Tavola Ricambi 645	See Tav. 645
2		Vedi Tavola Ricambi 645	See Tav. 645
3	88.60.64 88.60.48 88.60.49 88.60.50 88.60.51	Rotore fresa a zappe D 1600 Rotore fresa a zappe D 1800 Rotore fresa a zappe D 2100 Rotore fresa a zappe D 2300 Rotore fresa a zappe D 2500	Hoes rotor D 1600 Hoes rotor D 1800 Hoes rotor D 2100 Hoes rotor D 2300 Hoes rotor D 2500
* 3 *	88.60.67 88.60.68 88.60.69 88.60.70 88.60.71	* SOLO A RICHIESTA * Rotore fresa a zappe D 1600 – Flangia: Ø 300 mm / s=15 mm Rotore fresa a zappe D 1800 – Flangia: Ø 300 mm / s=15 mm Rotore fresa a zappe D 2100 – Flangia: Ø 300 mm / s=15 mm Rotore fresa a zappe D 2300 – Flangia: Ø 300 mm / s=15 mm Rotore fresa a zappe D 2500 – Flangia: Ø 300 mm / s=15 mm	*ONLY ON REQUEST* Hoes rotor D 1600 – Flange: Ø 300 mm / s=15 mm Hoes rotor D 1800 – Flange: Ø 300 mm / s=15 mm Hoes rotor D 2100 – Flange: Ø 300 mm / s=15 mm Hoes rotor D 2300 – Flange: Ø 300 mm / s=15 mm Hoes rotor D 2500 – Flange: Ø 300 mm / s=15 mm
4	26.00.01	Vite TE M14x1,5 L=33 pf classe 10.9	Screw TE M14x1,5 L=33 pf class 10.9
5	04.0.005	Grower serie pesante d 14	Grower d 14
6	25.50.13 sx 283 sx	Zappetta elicoidale sx (DI SERIE) Zappetta a SQUADRO sx (A RICHIESTA)	Lh hoe (STANDARD) Lh SQUARE hoe (ON REQUEST)
7	25.50.13 dx 283 dx	Zappetta a elicoidale dx (DI SERIE) Zappetta a SQUADRO dx (A RICHIESTA)	Rh hoe (STANDARD) Rh SQUARE hoe (ON REQUEST)
8	01.1.166	Vite TE M14x1,5 L=40 pf UNI 5738	Screw TE M14x1,5 L=40 pf UNI 5738
9	02.1.002	Dado M14x1,5 h=14 UNI 5587	Nut M14x1,5 h=14 UNI 5587
15	26.20.01	Dente rotoking a cuore	Plate tine rotoking
16	88.60.66 88.60.56 88.60.57 88.60.58 88.60.59	Rotore rotoking D 1600 passo=60 Rotore rotoking D 1800 passo=60 Rotore rotoking D 2100 passo=60 Rotore rotoking D 2300 passo=60 Rotore rotoking D 2500 passo=60	Rotoking rotor D 1600 pitch=60 Rotoking rotor D 1800 pitch=60 Rotoking rotor D 2100 pitch=60 Rotoking rotor D 2300 pitch=60 Rotoking rotor D 2500 pitch=60
17	24.01.95	Dente rotoking piegato dx	Rh rotoking tine
18	24.01.96	Dente rotoking piegato sx	Lh rotoking tine
19	24.01.31	Dente rotoking	Rotoking tine
20	26.40.02	Vite M10 L=60 pf testa rettangolare	Screw M10 L=60 pf
21	02.2.002	Dado autobloccante M10 h=12,3 UNI 7473	Selflocking nut M10 h=12,3 UNI 7473
22	01.1.158	Vite TE M14x1,5 L=75 pf UNI 5738	Screw TE M14x1,5 L=75 pf UNI 5738

FALC

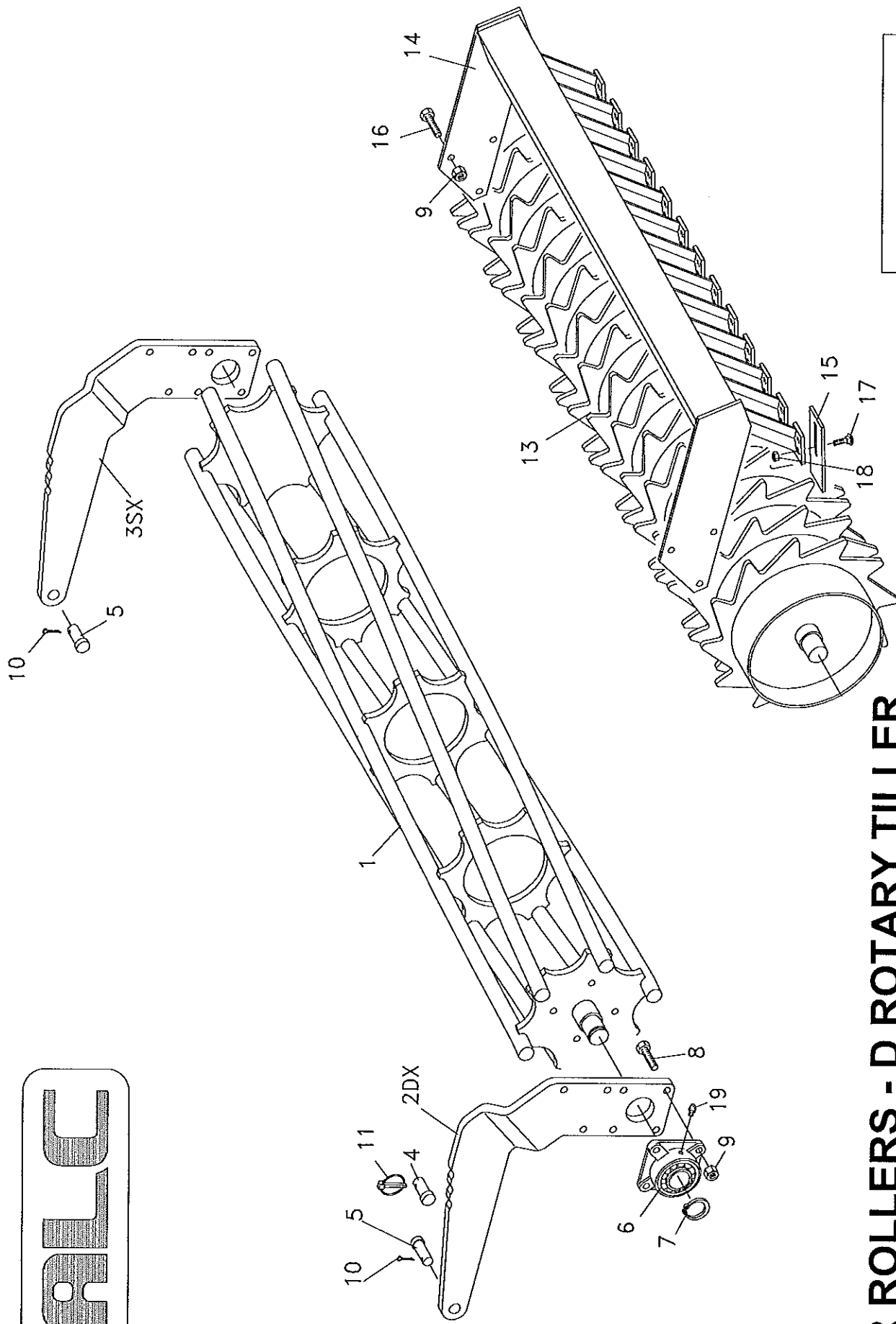

TAV.576

REAR ROLLERS - D ROTARY TILLER
RULLI POSTERIORI - FRESA D

Falc	Tavola Ricambi Parts Book	Rulli posteriori Rear rollers
pag.1	n.576 – 01/2007	FRESA D 1600-1800-2100-2300-2500 D 1600-1800-2100-2300-2500 rotary tiller

Pos. Fig.	Codice Item #	Descrizione Description
--------------	------------------	----------------------------

1	70.02.44	Rullo a gabbia Ø350/6 D 1600	Cage roller Ø350/6 D 1600
	70.02.25	Rullo a gabbia Ø350/6 D 1800	Cage roller Ø350/6 D 1800
	70.02.26	Rullo a gabbia Ø350/6 D 2100	Cage roller Ø350/6 D 2100
	70.02.27	Rullo a gabbia Ø350/6 D 2300	Cage roller Ø350/6 D 2300
	70.02.28	Rullo a gabbia Ø350/6 D 2500	Cage roller Ø350/6 D 2500
2	26.10.68	Braccio rullo dx lato trasmissione	Rh roller arm transmission side
3	26.10.69	Braccio rullo sx lato opposto trasmissione	Lh roller arm opposite transmission
4	51.70.29	Perno regolazione braccio rullo	Pin for roller adjustment
5	25.08.54	Perno cerniera braccio rullo	Pin for roller arm
6	06.4.003	Supporto a flangia quadra UCF 209	Support UCF 209
7	05.0.013	Seeger per esterni Ø45x1.75 UNI 7435	Snap ring Ø45x1.75 UNI 7435
8	01.0.256	Vite TE M14 L=50 pf UNI 5737	Screw TE M14 L=50 pf UNI 5737
9	02.4.004	Dado metalbloc M14 H=12	Metalbloc nut M14 H=12
10	05.3.010	Copiglia Ø5 L=30 UNI 1336	Split pin Ø5 L=30 UNI 1336
11	05.3.401	Spina a scatto Ø5 art.99	Release pin Ø5 art.99
13	70.02.45	Rullo packer Ø 450 D 1600	Packer roller Ø 450 D 1600
	70.02.03	Rullo packer Ø 450 D 1800	Packer roller Ø 450 D 1800
	70.02.04	Rullo packer Ø 450 D 2100	Packer roller Ø 450 D 2100
	70.02.05	Rullo packer Ø 450 D 2300	Packer roller Ø 450 D 2300
	70.02.06	Rullo packer Ø 450 D 2500	Packer roller Ø 450 D 2500
14		Tubo portaraschiatori packer D 1600	Scraper holder tube packer D 1600
		Tubo portaraschiatori packer D 1800	Scraper holder tube packer D 1800
		Tubo portaraschiatori packer D 2100	Scraper holder tube packer D 2100
		Tubo portaraschiatori packer D 2300	Scraper holder tube packer D 2300
		Tubo portaraschiatori packer D 2500	Scraper holder tube packer D 2500
15	54.30.01	Raschiatore packer Ø 450 (piatto 90x3 L=140)	Packer roller scraper Ø 450 (90x3 L=140)
16	01.0.254	Vite TE M14 L=40 tf UNI 5739	Screw TE M14 L=40 tf UNI 5739
17	01.4.001	Vite TTQST M10 L=25 UNI 5732	Screw TTQST M10 L=25 UNI 5732
18	02.2.002	Dado autobloccante M10 H=12.3 UNI 7473	Selflocking nut M10 H=12.3 UNI 7473
19	09.2.501	Ingrassatore diritto a spillo M6	Greaser M6