

www.falc.eu
e-mail: info@falc.eu



via Proventa n.41 – 48018 Faenza (Ra) - ITALY -
☎ +39 0546 29050
Fax +39 0546 663986

Catalogo Ricambi / Spare Parts Book

Modello / Model:

Fresa / Rotary Tiller EL

Matricola / Serial number:

.....

LATO DESTRO
RIGHT SIDE
CÔTÉ DROITE
RECHTS

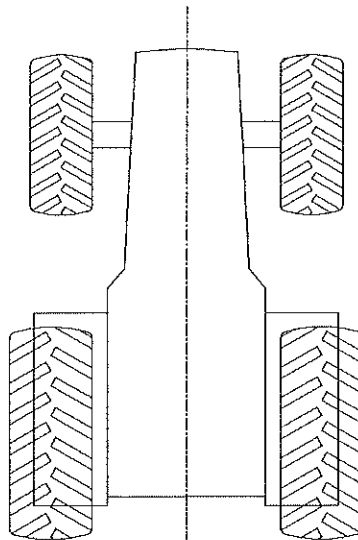

LATO SINISTRO
LEFT SIDE
CÔTÉ GAUCHE
LINKS



E-EL ROTARY TILLER
GEARBOX MZ 817 F

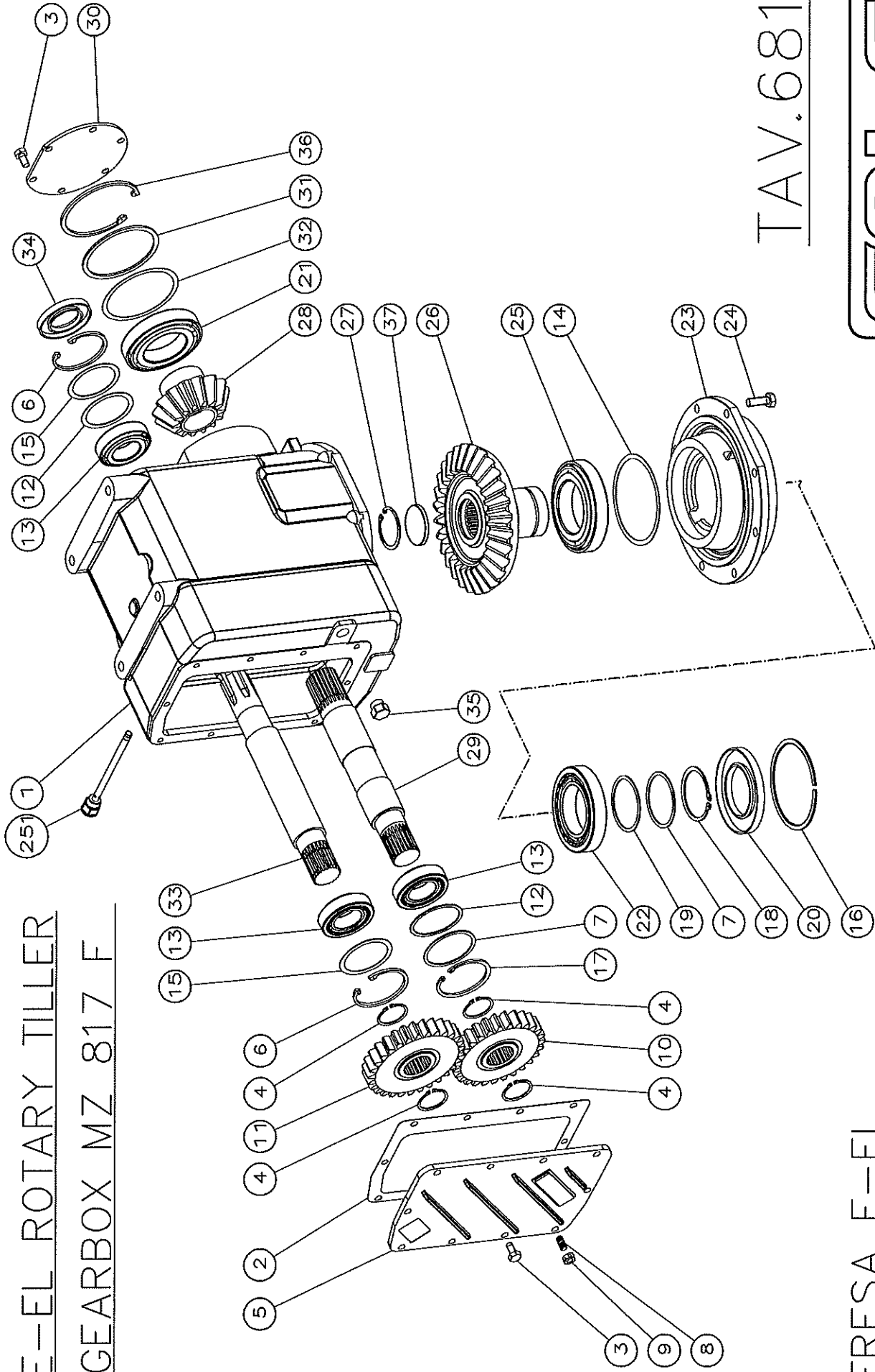

TAV.681

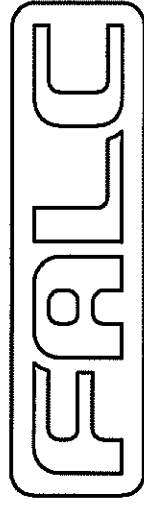

FRESA E-EL
RIDUTTORE MZ 817 F

Falc	Tavola Ricambi Parts Book	Riduttore MZ 817F Gearbox MZ 817F
pag.1	n. 681 04/2018	Fresa E E rotary tiller

Pos. Fig.	Codice Item #	Descrizione Description
--------------	------------------	----------------------------

Pos. Fig.	Codice Item #	Descrizione Description	
	90.0.063	RIDUTTORE MZ 817F – Comer cod. 9.817.403.10	GEARBOX MZ 817F – Comer item # 9.817.403.10
1	0.817.0300.00	Scatola	Gearbox
2	0.817.7201.00	Guarnizione	Gasket
3	01.0.152	Vite TE M10 L=20 UNI 5739 classe 8.8	Screw TE M10 L=20 UNI 5739 class 8.8
4	05.0.013	Seeger per esterni d 45 UNI 7435	Snap ring d 45 UNI 7435
5	0.817.1301.00	Coperchio posteriore	Rear cover
6	05.1.010	Seeger per interni d 85 UNI 7437	Snap ring d 85 UNI 7437
7	0.717.7520.00	Spessore di registro 75.2x84.2x2	Shim 75.2x84.2x2
8	8.1.5.01877	Vite prigioniera M10 L=22 UNI 5909	Screw M10 L=22 UNI 5909
9	02.0.403	Dado esagonale M10 UNI 5588	Hexagonal nut M10 UNI 5588
10	0.819.5045.00	Ingranaggi cambio z=27 m=5	Change gear z=27 m=5
	0.819.5039.00	Ingranaggi cambio z=24 m=5	Change gear z=24 m=5
11	0.819.5046.00	Ingranaggi cambio z=29 m=5	Change gear z=29 m=5
	0.819.5040.00	Ingranaggi cambio z=32 m=5	Change gear z=32 m=5
12	0.709.7500.00	Spessore di registro 70.3x84.7	Shim 70.3x84.7
13	06.1.040	Cuscinetto a rulli conici 32209	Taper roller bearing 32209
14	0.144.7500.00	Spessore registro 125.5x139.5	Shim 125.5x139.5
15	0.709.7510.00	Spessore registro 84.7x70.3x1	Shim 84.7x70.3x1
16	8.5.3.02004	Anello spallamento per alloggiamento SB130	Ring SB130
17	05.1.010	Seeger per interni d 85 UNI7437	Snap ring d 85 UNI7437
18	05.0.046	Seeger per esterni d 75 h=4 UNI 7436 serie pesante	Snap ring d 75 h=4 UNI 7436
19	0.717.7500.00	Spessore di registro 75.2x87.3	Shim 75.2x87.3
20	07.0.184	Paraolio 75x130x12 RP	Oil seal 75x130x12 RP
21	06.1.023	Cuscinetto a rulli conici 30214	Taper roller bearing 30214
22	06.1.043	Cuscinetto a rulli conici 30215	Taper roller bearing 30215
23	0.8106.1327.00	Flangia di uscita	Output flange
24	8.1.1.01891	Vite TE M12 L=35 UNI 5739 classe 10.9 DCRT320	Screw TE M12 L=35 UNI 5739 class 10.9 DCRT320
25	06.1.045	Cuscinetti a rulli conici 30216	Taper roller bearing 30216
26	0.819.6003.00	Corona conica z=29 m=7.87	Crown wheel z=29 m=7.87
27	05.1.001	Seeger per interni d 62 UNI 7437	Snap ring d 62 UNI 7437
28	0.819.5049.00	Pignone conico z=14 m=7.87	Pinion z=14 m=7.87
29	0.817.3000.00	Albero intermedio	Middle shaft
30	1.824.1300.00	Coperchio tranciato	Cover
31	0.819.7101.00	Distanziale 124.7x111x3	Spacer 124.7x111x3
32	0.819.7500.00	Spessore di registro 110.2x124.8	Shim 110.2x124.8
33	0.817.2000.00	Albero entrata	Input shaft
34	07.0.042	Paraolio 45x85x10	Oil seal 45x85x10
35	8.6.5.00203	Tappo conico esagono esterno 1/2	Cover 1/2
36	05.1.022	Seeger per interni d 125 UNI 7437	Snap ring d 125 UNI 7437
37	8.7.0.01359	Cappello di chiusura 62x7	Cover 62x7
251	0.812.7101.00	Tappo carico sfiato livello 1/2	Breather 1/2

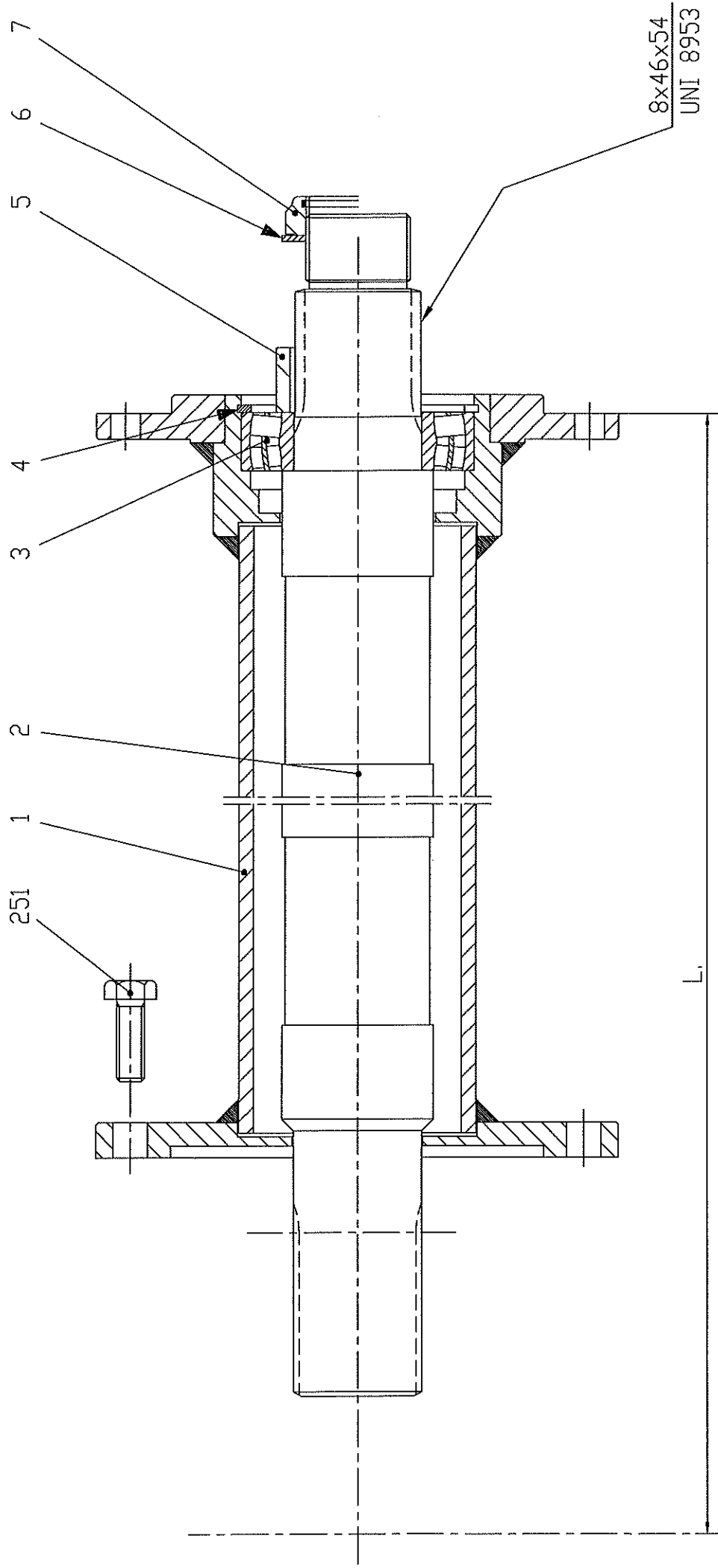

TAV. 810

FRESA EL
PROLUNGA RIDUTTORE MZ 817 F

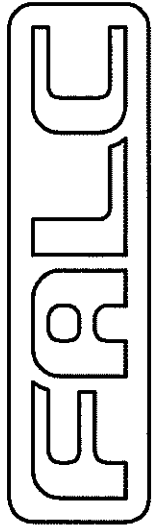

Falc	Tavola Ricambi Parts Book	Prolunga Riduttore MZ 817F Jackshaft Gearbox MZ 817F
pag.1	n.810 012/2013	Fresa EL EL rotary tiller

Pos. Fig.	Codice Item #	Descrizione Description	
	90.5.017	Per EH 1800 COMPLESSIVO PROLUNGA L=1000 cod. Comer 9.816.566.00	For EH 1800 ASSEMBLING - JACKSHAFT L=1800 item # Comer 9.816.566.00
	90.5.0.15	Per EL 2500 COMPLESSIVO PROLUNGA L=1350 cod. Comer 9.816.562.00	For EL 2500 ASSEMBLING - JACKSHAFT L=1350 item # Comer 9.816.562.00
	90.5.016	Per EL 3000 COMPLESSIVO PROLUNGA L=1600 cod. Comer 9.816.578.00	For EL 3000 ASSEMBLING - JACKSHAFT L=1600 item # Comer 9.816.578.00
1	2.816. ____ . __ 2.816.1353.00 2.816.1363.00	Prolunga L=1000 – EH 1800 Prolunga L=1350 – EL 2500 Prolunga L=1600 – EL 3000	Jackshaft L=1000 - EH 1800 Jackshaft L=1350 - EL 2500 Jackshaft L=1600 - EL 3000
2	0.816. ____ . __ 0.816.3155.00 0.816.3161.00	Albero L=1000 – EH 1800 Albero L=1350 – EL 2500 Albero L=1600 – EL 3000	Shaft L=1000 - EH 1800 Shaft L=1350 - EL 2500 Shaft L=1600 - EL 3000
3	06.2.005	Cuscinetto orientabile a rulli 22211	Roller bearing 22211
4	05.1.011	Anello elastico sicurezza x fori UNI 7437	Safety ring 100 UNI 7437
5	26.01.34	Distanziale	Spacer
6	0.252.7525.00	Spessore registro 65.3x45.3x2.5	Shim 65.3x45.3x2.5
7	8.2.6.02188	Ghiera autobloccante tipo pesante M45x1.5	Selflocking ring nut M45x1.5
251	01.1.121	Vite TE M12x1,5 L=35 cl.10.9 UNI 5740	Screw TE M12x1,5 L=35 cl.10.9 UNI 5740

FRESA EL

TAV.823

FALC

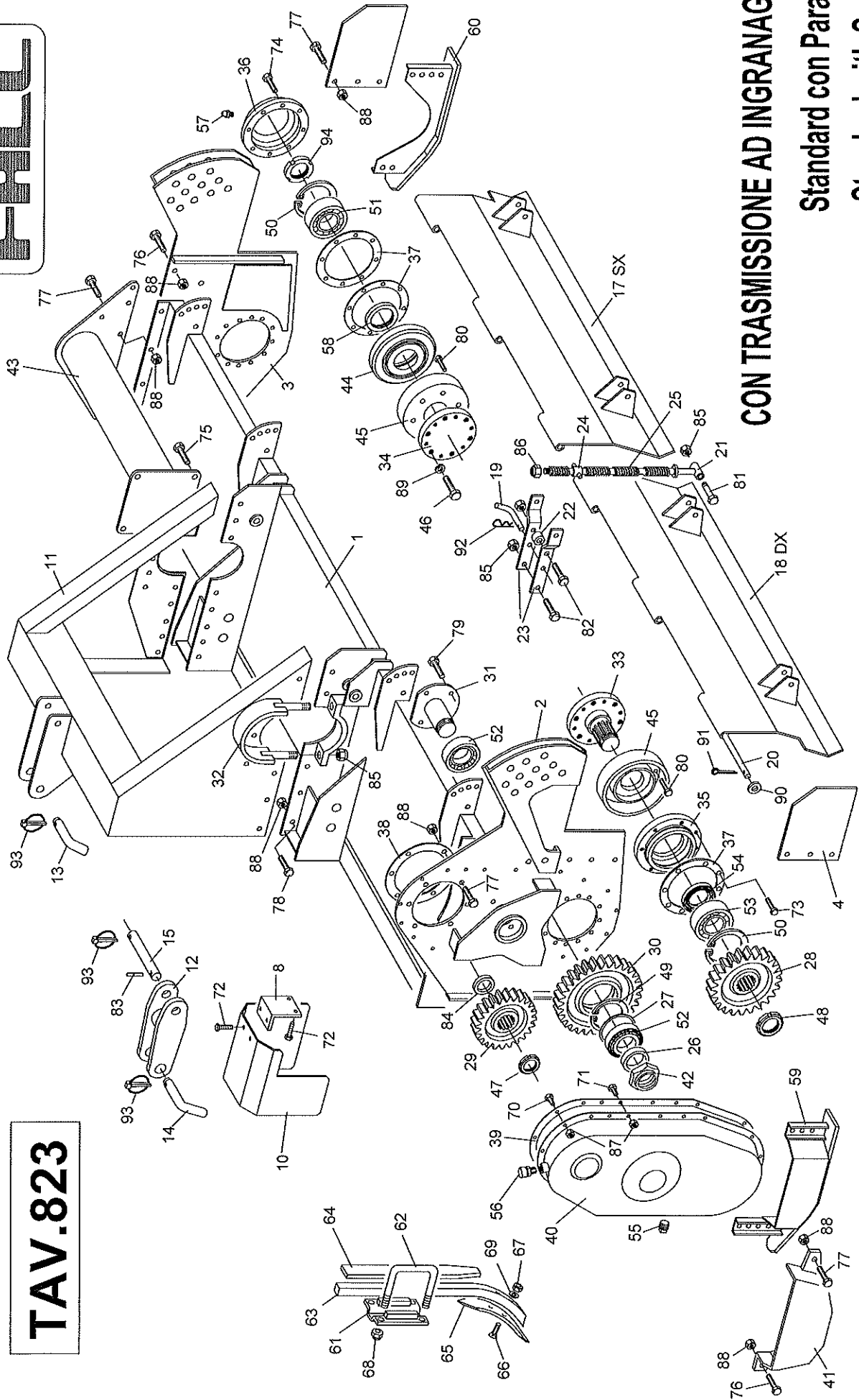

CON TRASMISSIONE AD INGRANAGGI
Standard con Paraoli
Standard with Seals

Falc	Tavola Ricambi Parts Book	Fresa E Larga EL rotary tiller
pag.1	n. 823 03/2013	Telaio e Trasmissione – Con Paraoli Frame and Drive – With Seals

Pos. Fig.	Codice Item #	Descrizione Description
----------------------	--------------------------	------------------------------------

		Fresa STANDARD con Paraoli. Per fresa con Tenute Stagne, vedere Tavola Ricambi n.828	STANDARD machine with Seals. For machine with Watertights, see Table Spare Parts n.828
1	26.21.06 26.21.07	Telaio 2500 Telaio 3000	Frame 2500 Frame 3000
2	26.21.08	Complessivo flangia trasmissione	Transmission flange
3	26.21.09	Compl. flangia opp. trasmissione	Opposite transmission flange
4	26.21.28	Fiancata posteriore lato trasmissione	Rear side transmission side
8	24.04.33	Supporto protezione pto esagonale	Support hexagonal PTO guarding
10	26.01.75	Protezione pto esagonale	Hexagonal PTO guarding
11	26.21.11	Attacco a 3 punti	3 point linkage
12	51.30.31	Attacco inferiore	Bottom linkage
13	53.10.53	Spina superiore	Top pin
14	25.02.66	Spina inferiore	Bottom pin
15	51.30.41	Perno snodo inferiore	Bottom articulation pin
17	26.21.20 26.21.22	Carter mobile 3500 Carter mobile 3000	Movable case 3500 Movable case 3000
18	26.21.21 26.21.23	Carter mobile lato opp. trasm. 2500 Carter mobile lato opp. trasm. 3000	Movable case opp. transmission 2500 Movable case opp. transmission 3000
19	24.01.81	Perno braccio per asta molla carter	Arm pin for case rod
20	24.10.41 25.13.07	Perno carter mobile 2500 Perno carter mobile 3000	Movable case pin 2500 Movable case pin 3000
21	24.60.00	Asta per ammortizzatore carter mobile	Shock absorber rod
22	26.50.40	Distanziale bracci ammortizzatore carter	Shock absorber arms spacer
23	26.50.39	Braccio ammortizzatore	Shock absorber arm
24	24.02.19	Boccola snodata per asta d 18	Bush for rod d 18
25	201	Molla attacco carter	Spring for case linkage
26	26.01.35	Distanziale esterno ingranaggio centrale	External spacer for central gear
27	26.01.36	Distanziale ingranaggio centrale	Central gear spacer
28	26.10.94	Ingranaggio inferiore Z=28	Bottom gear Z=28
29	26.10.92	Ingranaggio superiore Z=24	Top gear Z=24
30	26.10.93	Ingranaggio centrale Z=34	Central gear Z=34
31	26.10.98	Perno ingranaggio centrale	Pin for central gear
32	24.60.24	Cavallotto attacco riduttore	U bolt for gearbox linkage
33	26.00.05	Mozzo rotore lato trasmissione	Rotor hub transmission side
34	26.00.84	Mozzo rotore lato opposto trasmissione	Rotor hub opposite transmission
35	26.50.62	Supporto rotore lato trasmissione	Rotor support transmission side
36	26.50.66	Coperchio supporto rotore	Cap rotor support
37	26.50.65	Guarnizione supporto rotore	Gasket rotor support
38	24.02.01	Guarnizione prolunga riduttore	Gasket for jackshaft
39	26.10.91	Guarnizione carter copri-ingranaggi	Case gasket
40	26.01.32	Carter trasmissione ingranaggi	Transmission case
41	26.01.44	Protezione carter	Case transmission gears
42	70.01.04	Ghiera da acciaccare M50x1,5 h=18	Ring nut M50x1,5 h=18
43	26.21.12 26.21.13	Prolunga opposta trasmissione 2500 Prolunga opposta trasmissione 3000	Jackshaft opposite transmission 2500 L Jackshaft opposite transmission 3000 L
44	26.50.61	Supporto rotore lato opp. trasm.	Rotor support opposite transmission
45	26.50.72	Coperchietto di protezione	Guarding cap
46	01.1.189	Vite TE M14x1,5 L=30 tf UNI5740-10.9	Screw TE M14x1,5 L=30 tf UNI5740-10.9

Falc	Tavola Ricambi Parts Book	Fresa E Larga EL rotary tiller
pag.2	n. 823 03/2013	Telaio e Trasmissione – Con Paraoli Frame and Drive – With Seals

Pos. Fig.	Codice Item #	Descrizione Description	
47	03.1.009	Ghiera autobloc. GUP M45x1,5 h=16,5	Selflocking GUP nut M45x1,5 h=16,5
48	03.1.012	Ghiera autobloc. GUP M55x2 h=18,5	Selflocking GUP nut M55x2 h=18,5
49	05.1.011	Seeger per interni d 100 s=3 UNI 7437	Snap ring d 100 s=3 UNI 7437
50	05.1.004	Seeger per interni d 110 s=4 UNI 7437	Snap ring d 110 s=4 UNI 7437
51	06.0.022	Cuscinetto a sfere 6310 - 50x110x27	Ball bearing 6310 - 50x110x27
52	06.1.002	Cuscinetto a rulli conici 30211	Taper roller bearing 30211
53	06.2.003	Cuscinetto orientabile a rulli 22212 E	Roller bearing 22212 E
54	07.0.019	Paraolio 70x92x15 COMBI	Oil seal 70x92x15 COMBI
55	09.2.007	Tappo conico 3/4" con quadro esterno	Plug 3/4"
56	09.2.011	Tappo olio TS 36 1/2" gas	Oil plug TS 36 1/2"
57	09.2.504	Ingrassatore dritto M10 a spillo	Greaser M10
58	07.0.014	Paraolio 58x82x15 COMBI	Oil seal 58x82x15 COMBI
59	26.01.38	Slitta lato trasmissione	Skid transmission side
60	26.01.39	Slitta lato opposto trasmissione	Skid opposite transmission
61	51.90.01	Staffa per tubo 80x80	Bracket for tube 80x80
62	51.90.02	Cavallotto per tubo 80x80	U bolt for tube 80x80
63	51.90.00	Braccio dritto L=600	Straight arm L=750
64	51.90.03	Rinforzo posteriore dente	Rear reinforcement tine
65	24.40.40	Vomerino	Share
66	01.5.401	Vite TPSQST M12 L=60 UNI 6104	Screw TPSQST M12 L=60 UNI 6104
67	02.0.404	Dado M12 h=10 UNI 5588	Nut M12 h=10 UNI 5588
68	02.2.006	Dado autobloccante M18 h=21 UNI 7473	Selflocking nut M18 h=21 UNI 7473
69	04.0.004	Grower serie pesante d 12	Grower d 12
70	01.0.103	Vite TE M8 L=25 tf UNI 5739	Screw TE M8 L=25 tf UNI 5739
71	01.0.104	Vite TE M8 L=30 tf UNI 5739	Screw TE M8 L=30 tf UNI 5739
72	01.0.189	Vite TE M10 L=14 tf UNI 5739 zincata	Screw TE M10 L=14 tf UNI 5739 galvan.
73	01.0.204	Vite TE M12 L=30 tf UNI 5739	Screw TE M12 L=30 tf UNI 5739
74	01.0.207	Vite TE M12 L=45 pf UNI 5737	Screw TE M12 L=45 pf UNI 5737
75	01.0.301	Vite TE M16 L=30 tf UNI 5739	Screw TE M16 L=30 tf UNI 5739
76	01.1.151	Vite TE M14x1,5 L=30 tf UNI 5740	Screw TE M14x1,5 L=30 tf UNI 5740
77	01.1.152	Vite TE M14x1,5 L=35 tf UNI 5740	Screw TE M14x1,5 L=35 tf UNI 5740
78	01.1.166	Vite TE M14x1,5 L=40 pf UNI 5738	Screw M14x1,5 L=40 pf UNI 5738
79	01.0.252	Vite TE M14 L=30 tf UNI 5739	Screw M14 L=30 tf UNI 5739
80	01.0.101	Vite TE M8 L=16 tf UNI 5739	Screw M8 L=16 tf UNI 5739
81	01.1.237	Vite TE M16x1,5 L=100 pf UNI 5738 Z	Screw M16x1,5 L=100 pf UNI 5738 Z
82	01.1.228	Vite TE M16x1,5 L=50 pf UNI 5738 Z	Screw M16x1,5 L=50 pf UNI 5738 Z
83	05.2.106	Spina el. pesante d10 L=40 UNI6873	Split pin d10 L=40 UNI6873
84	26.01.34	Distanziale ingranaggio superiore	Spacer for top gear
85	02.3.004	Dado autobloc M16x1,5 h=18 UNI 7473	Selflocking nut M16x1,5 h=18 UNI 7473
86	02.3.005	Dado autobloc M18x1,5 h=21 UNI 7473	Selflocking nut M18x1,5 h=21 UNI 7473
87	02.4.002	Dado metalbloc M10 h=9	Metalbloc nut M10 h=9
88	02.5.003	Dado metalbloc M14x1,5 h=12	Metalbloc nut M14x1,5 h=12
89	04.0.005	Grower serie pesante d 14	Grower d 14
90	04.1.005	Rosetta d 16 17x35x3 comune cat.C	Washer d 16 17x35x3 cat.C
91	05.3.004	Copiglia d 4 L=30 UNI 1336	Split pin d 4 L=30 UNI 1336
93	05.3.402	Spina a scatto d 10 art.104	Release pin d 10 art.104
94	03.1.010	Ghiera autobloc. GUK M50x1,5 h=12,7	Selflocking GUK nut M50x1,5 h=12,7

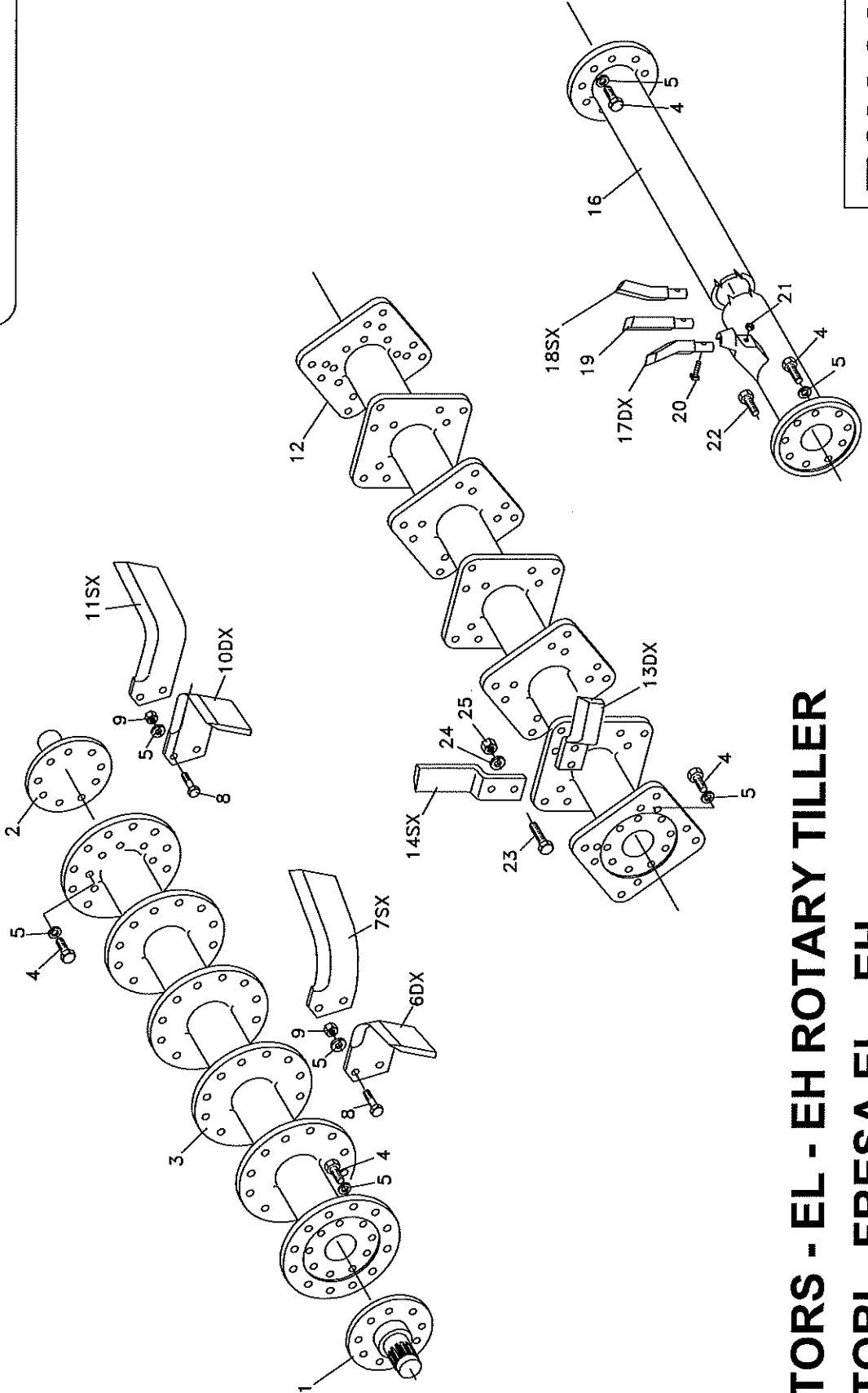
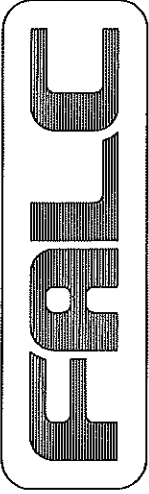

TAV.824

ROTORS - EL - EH ROTARY TILLER
ROTORI - FRESA EL - EH

Falc	Tavola Ricambi Parts Book	Fresa E Larga - EH EL - EH rotary tiller
pag.1	n. 824 05/2013	Rotori Rotors

Pos. Fig.	Codice Item #	Descrizione Description	
1	26.00.05	Mozzo rotore lato trasmissione	Rotor hub transmission side
2	26.00.84	Mozzo rotore lato opposto trasmissione	Rotor hub opposite transmission
3	26.21.26 26.21.27 26.61.57	Rotore fresa zappe 2500 EL Rotore fresa zappe 3000 EL Rotore fresa zappe 1800 EH	Hoes rotor 2500 EL Hoes rotor 3000 EL Hoes rotor 1800 EH
4	01.1.189	Vite TE M14x1,5 L=30 tf – UNI 5740 - classe 10.9 (ex cod. 26.00.01 - Vite TE M14x1,5 L=33 pf classe 10.9)	Screw TE M14x1,5 L=30 tf – UNI 5740 - class 10.9 (item # 26.00.01 - Screw TE M14x1,5 L=33 pf class 10.9)
5	04.0.005	Grower serie pesante d 14	Grower d 14
6	303	Zappa curva dx	Rh hoe
7	302	Zappa curva sx	Lh hoe
8	01.1.166	Vite TE M14x1,5 L=40 pf UNI 5738 classe 8.8	Screw TE M14x1,5 L=40 pf UNI 5738 class 8.8
9	02.1.002	Dado esagonale M14x1,5 h=14 UNI 5587	Hexagonal nut M14x1,5 h=14 UNI 5587
10	10.07.04	Zappa a squadro dx	Rh square hoe
11	10.07.05	Zappa a squadro sx	Lh square hoe
12	26.21.67 26.21.68 26.61.72	Rotore terraking tipo 2 – 2500 EL Rotore terraking tipo 2 – 3000 EL Rotore terraking tipo 2 – 1800 EH	Terraking rotor type 2 -2500EL Terraking rotor type 2 -3000EL Terraking rotor type 2 -1800EH
13	10.40.48	Coltello dx terraking tipo 2	Rh terraking blade type 2
14	10.40.49	Coltello sx terraking tipo 2	Lh terraking blade type 2
16	26.21.63 26.21.64 26.61.60 26.21.65 26.21.66 26.61.73	Rotore rotoking 2500 EL – passo I=60 Rotore rotoking 3000 EL – passo I=60 Rotore rotoking 1800 EH – passo I=60 Rotore rotoking 2500 EL – passo I=50 Rotore rotoking 3000 EL – passo I=50 Rotore rotoking 1800 EH – passo I=50	Rotoking rotor 2500 EL – pitch I=60 Rotoking rotor 3000 EL – pitch I=60 Rotoking rotor 1800 EH – pitch I=60 Rotoking rotor 2500 EL – pitch I=50 Rotoking rotor 3000 EL – pitch I=50 Rotoking rotor 1800 EL – pitch I=50
17	24.01.95	Dente rotoking piegato dx	Rh rotoking tine
18	24.01.96	Dente rotoking piegato sx	Lh rotoking tine
19	24.01.31	Dente rotoking	Rotoking tine
20	26.40.02	Vite testa rettangolare fissaggio dente M10 L=60 pf	Screw for rotoking tine M10 L=60
21	02.2.002	Dado autobloccante M10 h=12,3 UNI 7473	Selflocking nut M10 h=12,3 UNI 7473
22	01.1.158	Vite TE M14x1,5 L=75 pf UNI 5738	Screw TE M14x1,5 L=75 pf UNI 5738
23	24.50.70	Vite TE M16x1,5 L=44 pf classe 10.9	Screw TE M16x1,5 L=44 pf class 10.9
24	04.0.006	Grower serie pesante d 16	Grower d 16
25	02.5.004	Dado metalbloc M16x1,5 h=14	Metalbloc nut M16x1,5 h=14

FALC

TAV.813

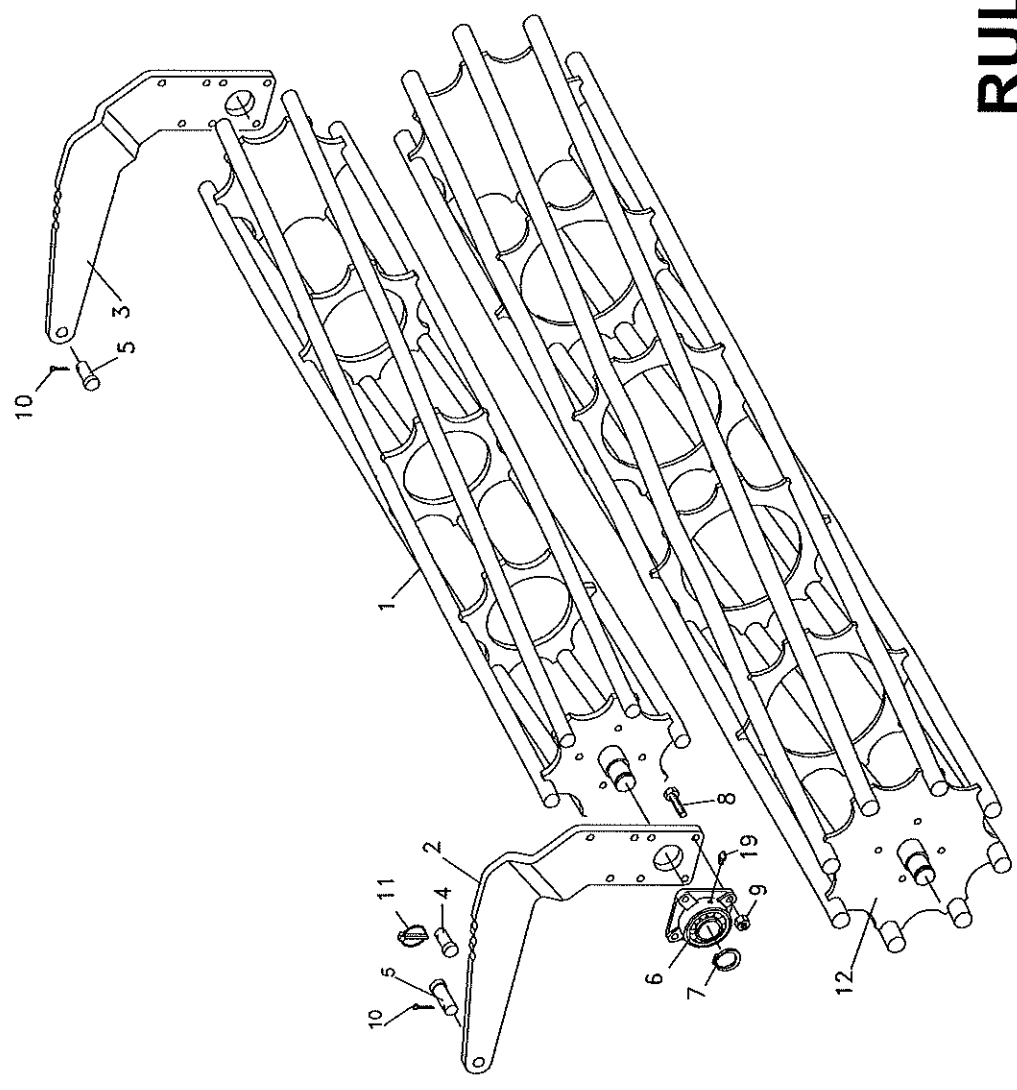

**RULLI POSTERIORI
FRESA EL**

Falc	Tavola Ricambi Parts Book	Fresa EL EL rotary tiller
pag.1	n. 813 02/2018	Rulli posteriori Rear rollers

Pos. Fig.	Codice Item #	Descrizione Description	
1	26.21.46 26.21.47	EL 2500 Rullo a gabbia d 350/6 EL 3000 Rullo a gabbia d 350/6	EL 2500 Cage roller d 350/6 EL 3000 Cage roller d 350/6
2	26.21.39	Braccio rullo dx lato trasmissione	Rh roller arm transmission side
3	26.21.40	Braccio rullo sx lato opposto trasmissione	Lh roller arm opposite transmission
4	51.70.29	Perno regolazione braccio rullo	Pin for roller adjustment
5	25.08.54	Perno cerniera braccio rullo	Pin for roller arm
6	06.4.003	Cuscinetto UCF 209	Bearing UCF 209
7	05.0.013	Seeger per esterni d 45 s=1,75 UNI 7435	Snap ring d 45 s=1,75 UNI 7435
8	01.0.256	Vite TE M14 L=50 pf UNI 5737	Screw TE M14 L=50 pf UNI 5737
9	02.4.004	Dado metalbloc M14 h=12	Metalbloc nut M14 h=12
10	05.3.010	Copiglia d 5 L=30 UNI 1336	Split pin d 5 art.99
11	05.3.401	Spina a scatto d 5 art.99	Release pin d 5 art.99
12	26.21.48 26.21.49	EL 2500 Rullo a gabbia d 450/8 EL 3000 Rullo a gabbia d 450/8	EL 2500 Cage roller d 450/8 EL 3000 Cage roller d 450/8
19	09.2.501	Ingrassatore dritto a spillo M 6	Greaser M 6

TAV.864

RULLI FRESA EL CON
RASCHIATORI REGOLABILI

RULLO PACKER Ø550

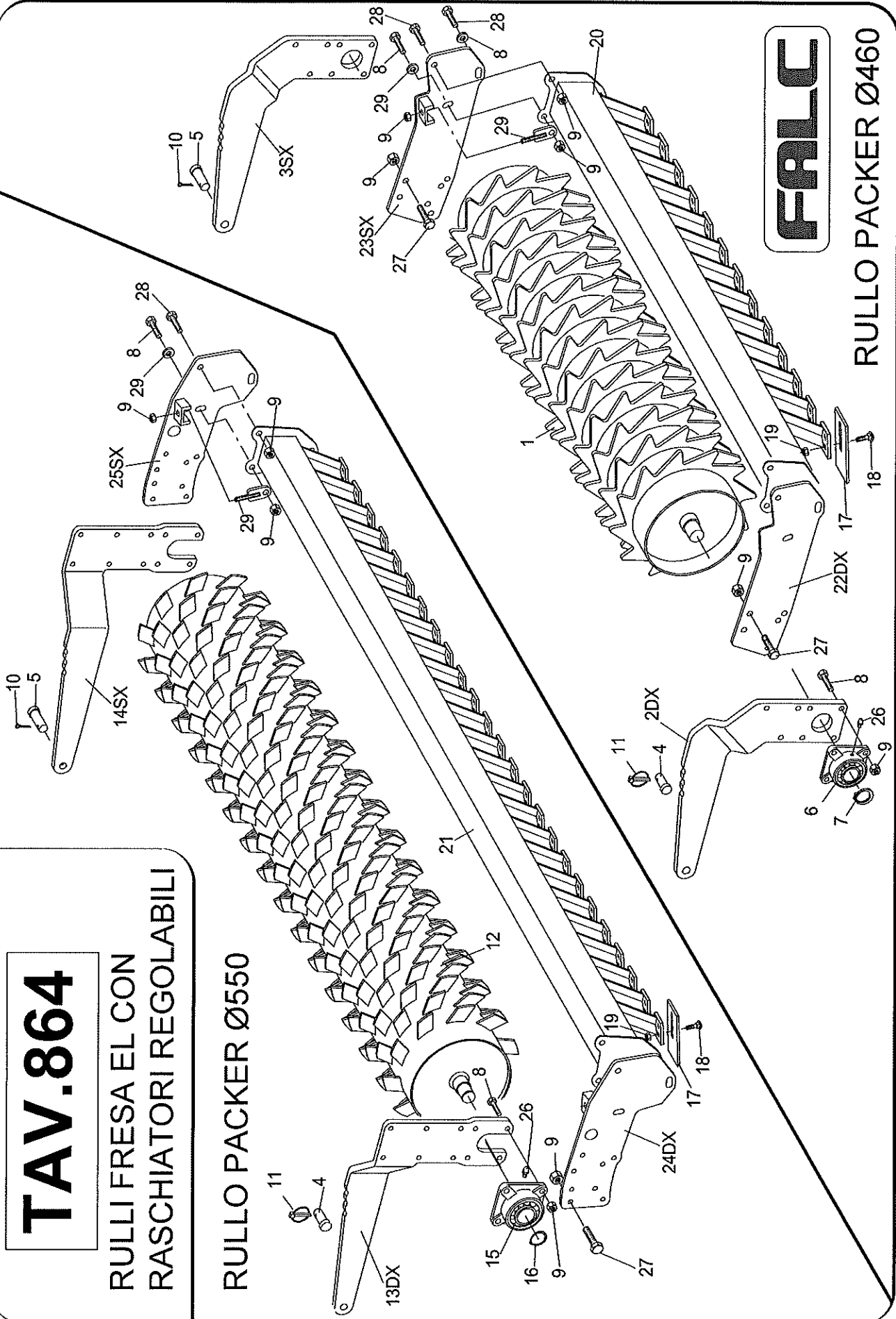

FALC

RULLO PACKER Ø460

Falc	Tavola Ricambi Parts Book	Fresa EL EL rotary tiller
pag.1	n. 864 02/2018	Rulli packer con raschiatori regolabili Rear rollers with adjustable scrapers

Pos. Fig.	Codice Item #	Descrizione Description	
1	26.21.56 26.21.57	EL 2500 Rullo packer 460 EL 3000 Rullo packer 460	EL 2500 Packer roller 460 EL 3000 Packer roller 460
2	26.21.39	Braccio packer 460 dx lato trasmissione	Rh packer 460 arm transmission side
3	26.21.40	Braccio packer 460 sx lato opposto trasmissione	Lh packer 460 arm opposite transmission
4	51.70.29	Perno regolazione braccio rullo	Pin for roller adjustment
5	25.08.54	Perno cerniera braccio rullo	Pin for roller arm
6	06.4.003	Cuscinetto UCF 209	Bearing UCF 209
7	05.0.013	Seeger per esterni d 45 s=1,75 UNI 7435	Snap ring d 45 s=1,75 UNI 7435
8	01.0.256	Vite TE M14 L=50 pf UNI 5737	Screw TE M14 L=50 pf UNI 5737
9	02.4.004	Dado metalbloc M14 h=12	Metalbloc nut M14 h=12
10	05.3.010	Copiglia d 5 L=30 UNI 1336	Split pin d 5 art.99
11	05.3.401	Spina a scatto d 5 art.99	Release pin d 5 art.99
12	26.21.58 69.40.89	EL 2500 Rullo packer d 550 EL 3000 Rullo packer d 550	EL 2500 Packer roller d 550 EL 3000 Packer roller d 550
13	26.21.36	Braccio packer 550 dx lato trasmissione	Rh packer 550 arm transmission side
14	26.21.38	Braccio packer 550 sx lato opposto trasmissione	Lh packer 550 arm opposite transmission
15	06.4.004	Cuscinetto UCF 210	Bearing UCF 210
16	05.0.031	Seeger per esterni d 50 s=2 UNI 7435	Snap ring d 50 s=2 UNI 7435
17	54.30.01	Raschiatore rullo packer (piatto 90x3 L=140)	Packer roller scraper (90x3 L=140)
18	01.4.001	Vite TTQST M10 L=25 UNI 5732	Screw TTQST M10 L=25 UNI 5732
19	02.2.002	Dado autobloccante M10 h=12,3 UNI 7473	Selflocking nut M10 h=12,3 UNI 7473
20	26.31.10	EL 2500 Barra portaraschiatori regolabile packer 460	EL 2500 Adjustable scraper holder barpacker 460
	26.31.11	EL 3000 Barra portaraschiatori regolabile packer 460	EL 3000 Adjustable scraper holder barpacker 460
21	26.31.12	EL 2500 Barra portaraschiatori regolabile packer 550	EL 2500 Adjustable scraper holder bar packer 550
	26.31.13	EL 3000 Barra portaraschiatori regolabile packer 550	EL 3000 Adjustable scraper holder barpacker 550
22	25.13.53	Packer 460 Flangia regolabile DX per telaio portaraschiatori	Packer 460 Rh adjustable flange for frame scraper holder
23	25.13.54	Packer 460 Flangia regolabile SX per telaio portaraschiatori	Packer 460 Lh adjustable flange for frame scraper holder
24	54.21.44	Packer 550 Flangia regolabile DX per telaio portaraschiatori	Packer 550 Rh adjustable flange for frame scraper holder
25	54.21.45	Packer 550 Flangia regolabile SX per telaio portaraschiatori	Packer 550 Rh adjustable flange for frame scraper holder
26	09.2.501	Ingrassatore dritto a spillo M 6	Greaser M 6
27	01.0.254	Vite TE M14 L=40 tf UNI 5739	Screw TE M14 L=40 tf UNI 5739
28	01.0.253	Vite TE M14 L=35 tf UNI 5739	Screw TE M14 L=40 tf UNI 5739
29	54.21.28	Tirante raschiatori regolabili	Tie rod for adjustable scrapers

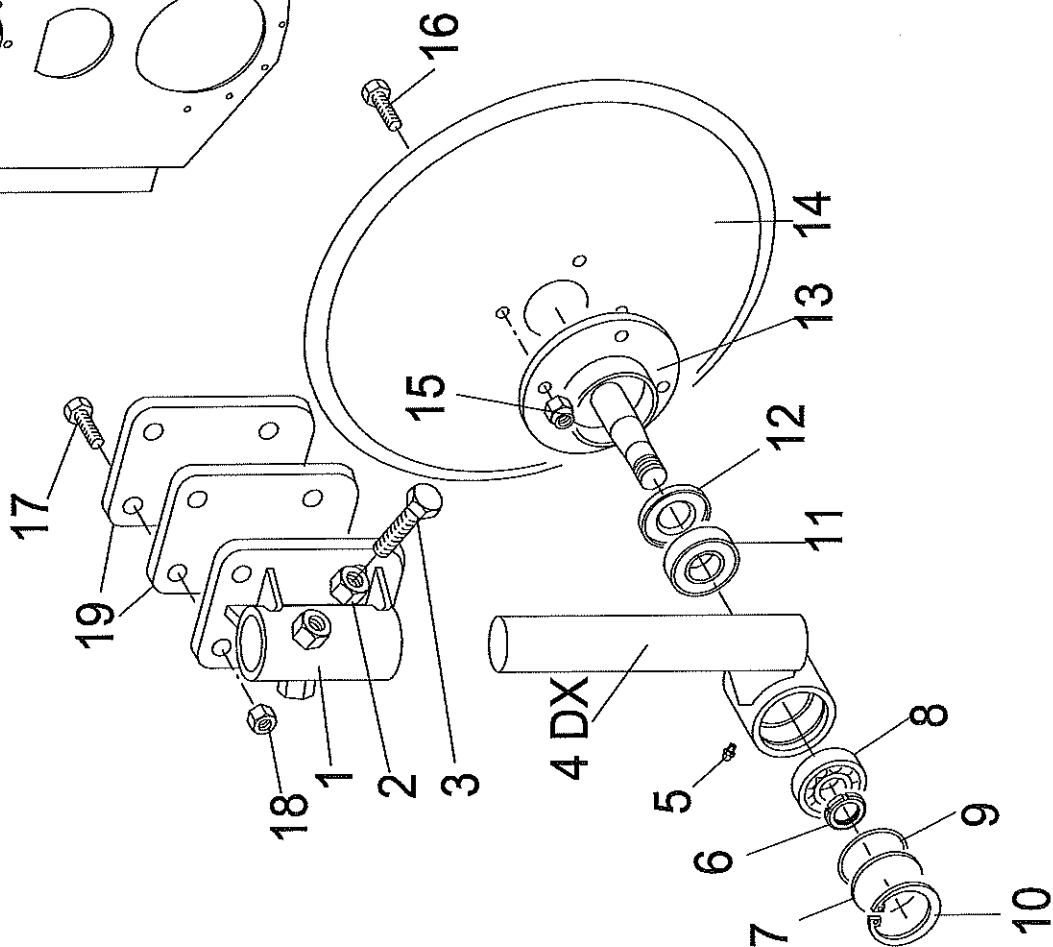
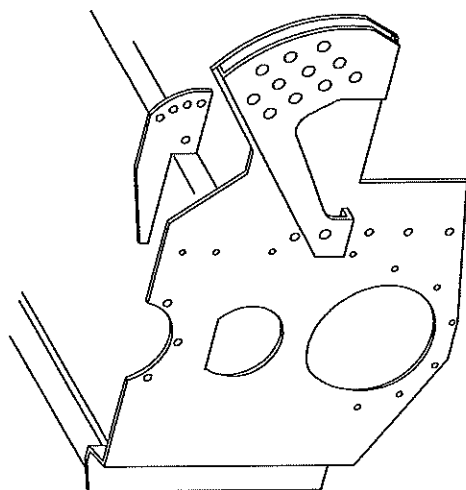
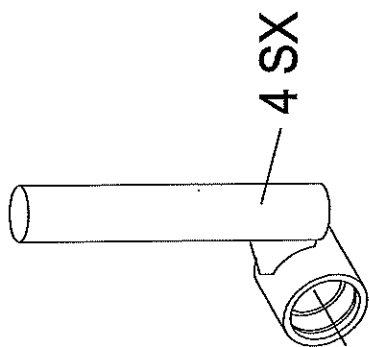

DISCO ANTERIORE

TAV. 806

FALC

Falc	Tavola Ricambi Parts Book	Frese 2014 Rotary Tillers 2014
pag.1	n. 806 03/2014	Disco anteriore Front disc

Pos. Fig.	Codice Item #	Descrizione Description
----------------------	--------------------------	------------------------------------

	811.36	Coppia Dischi Anteriori (DX + SX) (Questo codice comprende anche n.2 supporti pos.1 e gli spessori pos.19)	Pair of Front Discs (RH + LH) (This item includes also 2 x supports fig. 1 and the shims fig. 19)
1	25.12.57	Attacco disco	Disc linkage
2	02.0.005	Dado M16 h=16 UNI 5587	Nut M16 h=16 UNI 5587
3	01.0.342	Vite TE M16 l=50 tf UNI 5739	Screw TE M16 l=50 tf UNI 5739
4	10.08.86 10.08.87	Supporto disco DX Supporto disco SX	RH disc support LH disc support
5	09.2.504	Ingrassatore dritto a spillo M10	Greaser M10
6	03.1.001	Ghiera autobloccante GUP M25x1,5 h=14	Selflocking GUP nut M25x1,5 h=14
7	26.50.02	Coperchietto disco anteriore	Front disc cap
8	06.1.005	Cuscinetto a rulli conici 30305	Taper roller bearing 30305
9	07.1.007	Guarnizione OR 3256	Gasket OR 3256
10	05.1.002	Seeger per interni d 70 s=2,5 UNI 7437	Snap ring d 70 s=2,5 UNI 7437
11	06.1.008	Cuscinetto a rulli conici 32206	Taper roller bearing 32206
12	07.0.003	Paraolio 42x62x14 COMBI	Oil seal 42x62x14 COMBI
13	26.60.74	Complessivo mozzo disco	Disc hub
14	26.60.72	Disco anteriore	Front disc
15	02.5.002	Dado metalbloc M12x1,25 h=11	Metalbloc nut M12x1,25 h=11
16	01.1.101	Vite TE M12x1,25 L=25 tf UNI 5740	Screw TE M12x1,25 L=25 tf UNI 5740
17	01.0.305	Vite TE M16 L=60 pf UNI 5737	Screw TE M16 L=60 pf UNI 5737
18	02.4.005	Dado metalbloc M16 h=14	Metalbloc nut M16 h=14
19	25.12.55	Flangia spessore s=12	Flange s=12
20			
21			
22			

SPECIAL for SOLEX

For rotary tillers

EL 3000

RH case cod.26.21.71
LH case cod.26.21.72

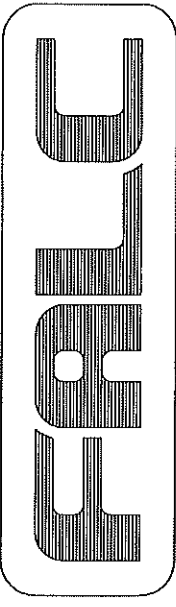

TAV.855

