

via Proventa n.41 - Faenza (Ra) - ITALY -
Tel. 0546 29050
Fax 0546 663986

CATALOGO RICAMBI

Modello: **ALCE 2300-2500**

Matricola: **TIPO USA**

Rivenditore / Dealer / Händler / Concessionnaire

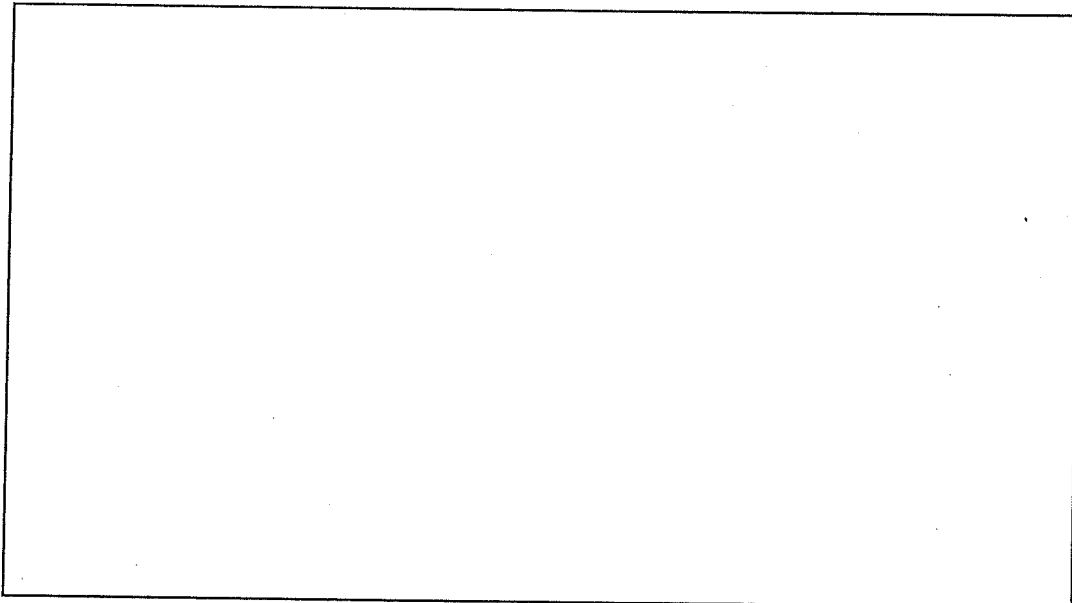

TAV. 342 - MOLTIPLICATORE TL 311 D - ALCE 1600 - 1950 - 2300 - 2500 FALC

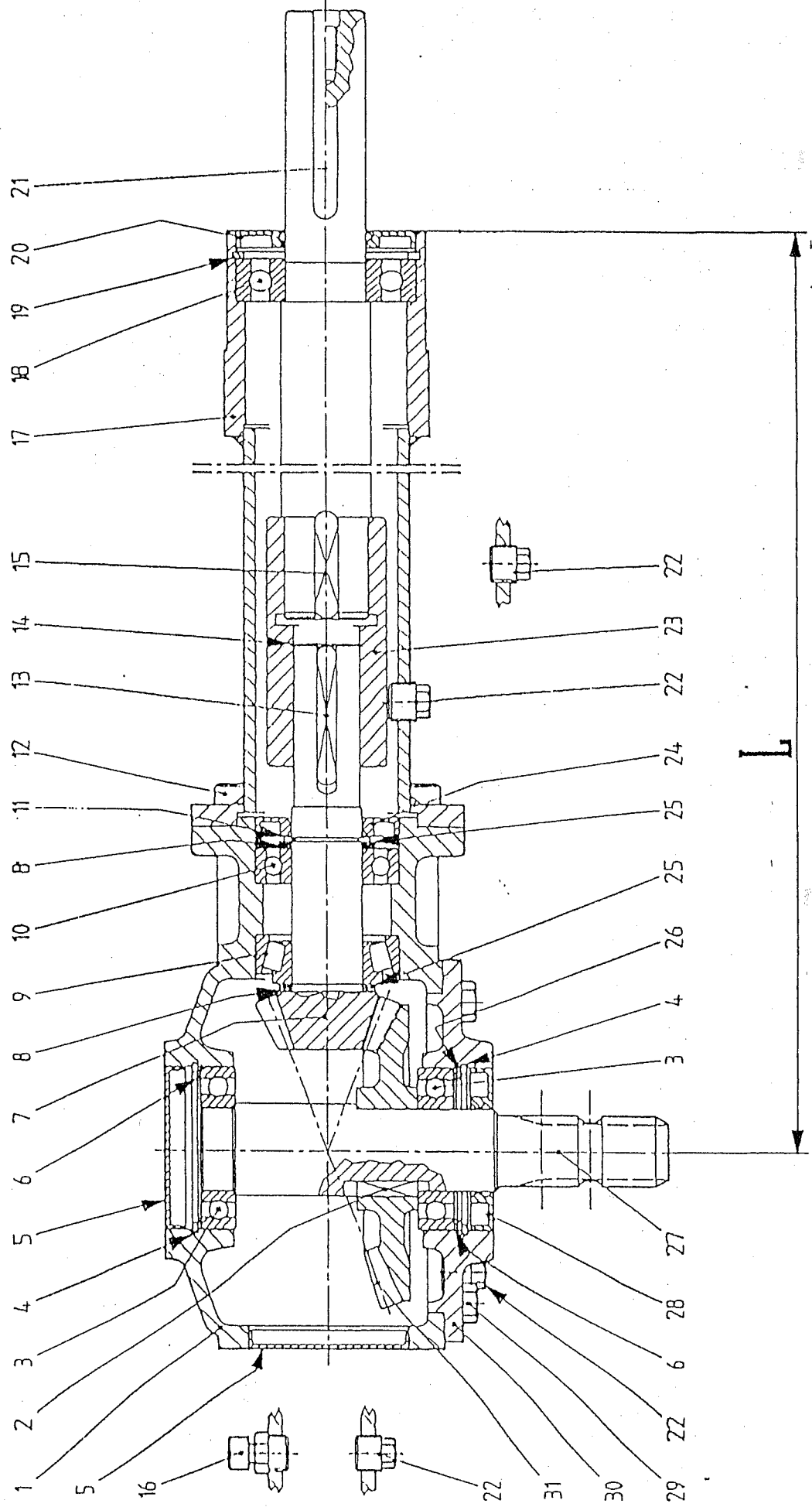

Tav. 342 07 96

Molt.TL 311D - Alce 1600-1950-2300-2500

Pos.	Codice	Denominazione
1	0.311.0300.00	scatola
2	8.4.1.01141	linguetta temprata B 12x8x30 UNI 6604
3	06.0.032	cuscinetto a sfere 6208
4	05.1.012	seeger per interni d 80 s=2,5 UNI 7437
5	8.7.0.00790	cappello di chiusura 80x10
6	0.267.7500.00	spessore di registro 69x79,9
7	0.304.5014.00	albero - pignone z=11 m=5,35
8	0.259.7513.00	spessore di registro 48,0x35,3x1,3
9	06.1.009	cuscinetto a rulli conici 32207
10	06.0.014	cuscinetto a sfere 6207
11	05.0.009	seeger per esterni d 35 s=1,5 UNI 7435
12	01.2.204	vite TCEI M12 L=30 tf UNI 5931
13	8.4.1.01689	linguetta temprata A 10x8x65 UNI 6604
14	05.1.014	seeger per interni d 33 s=1,2 UNI 7437
15	8.4.1.01630	linguetta temprata A 12x8x50 UNI 6604
16	8.6.7.00161	tappo sfiato anticondensa 3/8" gas
17	2.312.1313.00	prolunga L=810 alce 1600
	2.312.1304.00	prolunga L=1060 alce 1950-2300
	2.312.1312.00	prolunga L=1140 alce 2500
18	06.0.020	cuscinetto a sfere 6308
19	05.1.003	seeger per interni d 90 s=3 UNI 7437
20	07.0.068	paraolio 40x90x8/7 con parapolvere
21	0.312.3745.00	albero liscio L=810 alce 1600
	0.312.3747.00	albero liscio L=1060 alce 1950
		albero liscio L=1060 alce 2300
	0.312.3717.00	albero liscio L=1140 alce 2500
22	8.6.6.00201	tappo conico con esagono esterno 3/8" gas
23	0.312.7000.00	boccola
24	07.0.029	paraolio 35x72x10
25	0.259.7500.00	spessore di registro 35,3x48,0
26	0.267.7510.00	spessore di registro 69,0x79,7x1,0
27	0.304.3000.00	albero
28	07.0.069	paraolio 40x80x12 con parapolvere
29	01.0.153	vite TE M10 L=25 tf UNI 5739
30	0.311.1300.00	coperchio aperto
31	0.304.6200.00	corona z=28 m=5,35

TAV. 81 TRINCIA ALCE 1600-1950-2300-2500 -2700 - Ruota sterzante

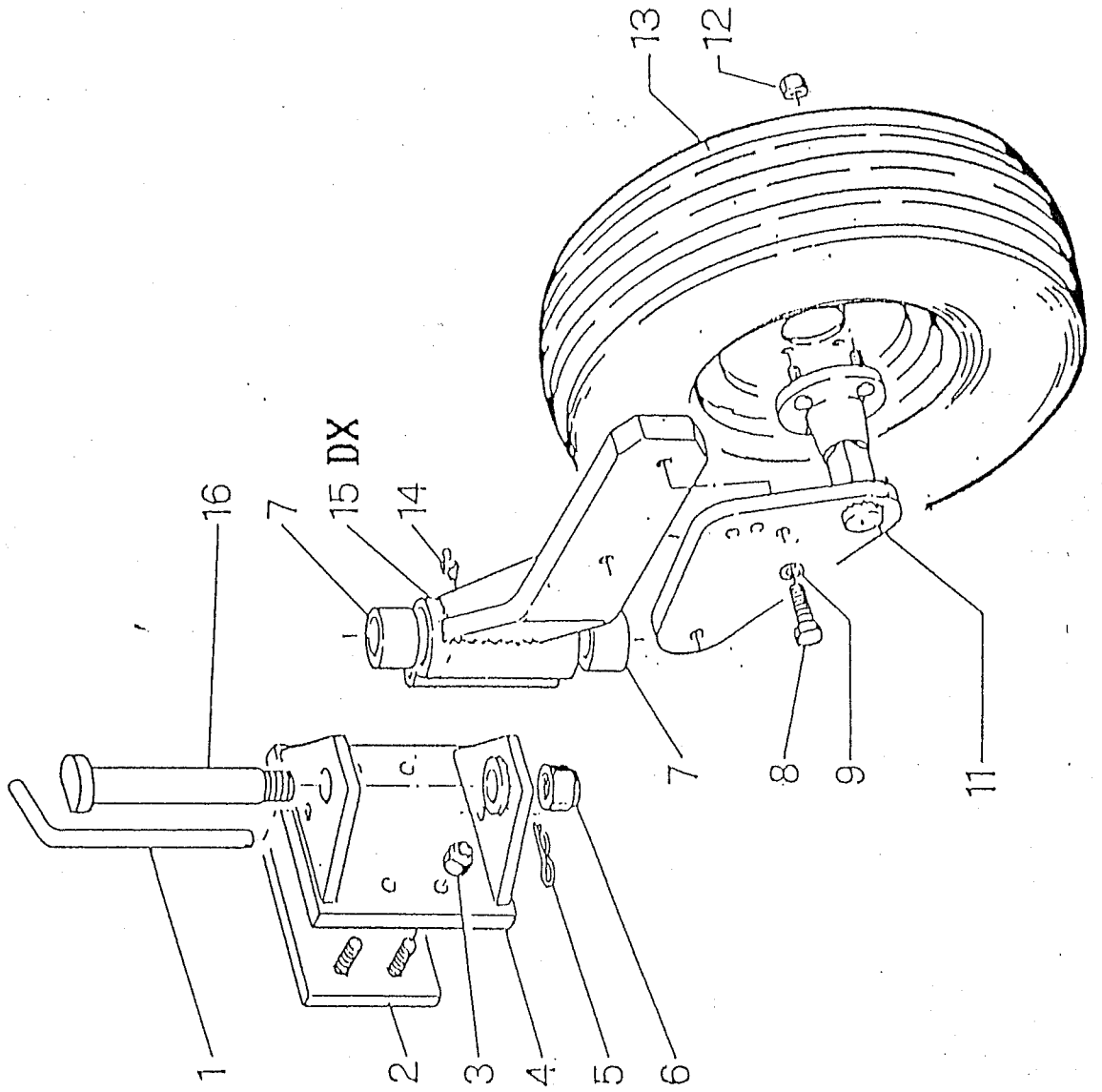

FRALC

Tav. 81 09 95

TRINCIA ALCE Ruota sterzante

Pos.	Codice	Denominazione
1	43.00.82	spina bloccaggio ruota sterzante
2	43.00.52	piastra di fissaggio attacco ruota
3	02.0.005	dado autobloccante M16 h=18 UNI 7473
4	43.00.72A	attacco snodo ruota sterzante
5	05.3.202	copiglia a molla d 4 L=76 art.114
6	02.3.504	dado autobloccante M30x2 h=24,5 UNI 7474
7	3007/1B	boccola autolubrificante
8	01.0.318	vite TE M16 L=45 tf UNI 5739 zincata Alce 1600-1950-2300
	01.0.404	vite TE M20 L=45 tf UNI 5739 zincata Alce 2500-2700
9	04.0.006	grower serie pesante d=16
	04.0.008	grower serie pesante d=20
11	43.01.94	flangia dx con mozzo ruota Alce 1600-1950-2300
	43.07.73	flangia sx con mozzo ruota Alce 1600-1950-2300
	49.03.03	flangia dx con mozzo ruota Alce 2500-2700
	49.03.04	flangia sx con mozzo ruota Alce 2500-2700
12	02.6.601	dado esagonale M12x1,5 con calotta h=14,8 Alce1600-1950-2300
	02.6.602	dado esagonale M16x1,5 con calotta h=18 Alce 2500-2700
13	10.1.014	ruota 135/80/14 - 4 fori Alce 1600-1950-2300
	10.1.010	ruota 8.00-14 RI - 5 fori Alce 2500-2700
	10.1.013	ruota 8.00-15 RI - 5 fori Alce 2500-2700
14	09.2.503	ingrassatore dritto a spillo m10
15	43.00.76	snodo ruota sterzante dx Alce 1600-1950-2300
	43.00.77	snodo ruota sterzante sx Alce 1600-1950-2300
	41.01.54	snodo ruota sterzante Alce 2500-2700
16	43.00.71	perno snodo ruota sterzante

FALC

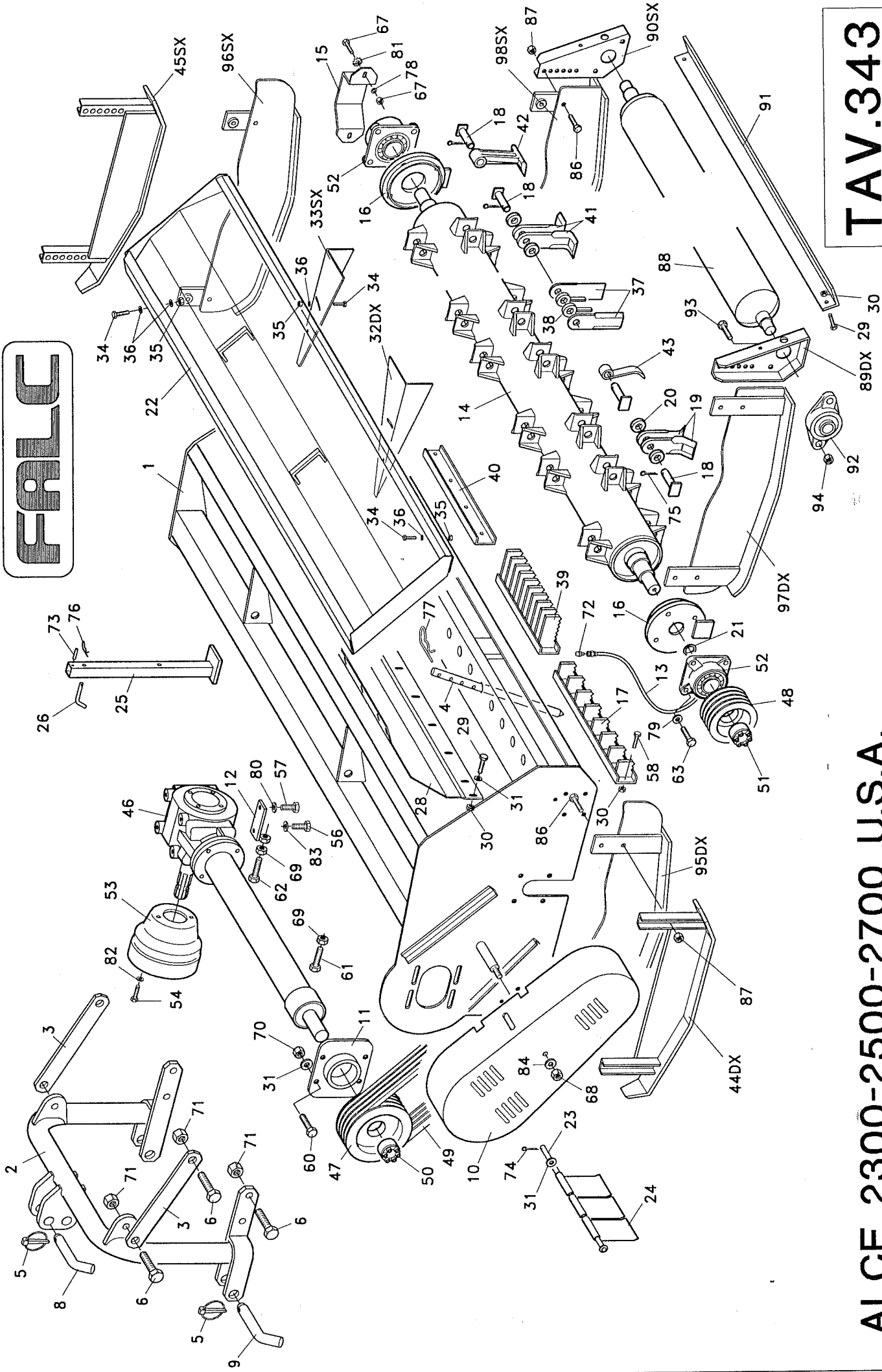

TAV.343

ALCE 2300-2500-2700 U.S.A.

Tav. 343 07 96

Alce 2300 - 2500 - 2700 U.S.A.

Pos.	Codice	Denominazione
1	68.00.02	complessivo telaio alce 2300 U.S.A.
	68.00.03	complessivo telaio alce 2500 U.S.A.
	68.00.04	complessivo telaio alce 2700 U.S.A.
2	68.00.05	attacco a 3 punti alce U.S.A.
3	68.00.06	piatto tirante attacco a 3 punti alce U.S.A.
4	43.02.92	dente rastrello
5	05.3.402	spina a scatto d 10 L=58 art. 104
6	01.1.254	vite TE M18x1,5 L=60 pf UNI 5738
8	36.03.58	spina superiore II categoria
9	25.02.66	spina attacco 3° punto inferiore
10	43.04.60	carter copricinghie
11	43.09.63	complessivo regolazione cinghie TL311-TL312
12	43.04.90	attacco scatola parte mobile TL 311 alce 2300-2500
	43.06.88	attacco scatola parte mobile TL 312 alce 2700
13	49.03.52	prolunga ingrassatore
14	43.05.62	rotore alce 2300
	43.07.83	rotore alce 2500
	43.08.82	rotore alce 2700
15	43.08.59	protezione cuscinetto UCF 209 - 210
16	43.05.95	flangia supporto UCF 210
17	43.08.34	controcoltello per coltelli tipo 01 L=2275 alce 2300
	41.09.46	controcoltello per coltelli tipo 01 L=2455 alce 2500
	43.08.79	controcoltello per coltelli tipo 01 L=2635 alce 2700
18	42.03.35	perno porta coltello
19	43.01.51	coltello tipo 01
20	43.00.65	distanziale coltelli tipo 01 - 05
21	42.01.90	rasamento regolazione rotore D=60 ; d=50,1 ; s=1
	42.01.92	rasamento regolazione rotore D=60 ; d=50,1 ; s=2
	42.01.91	rasamento regolazione rotore D=60 ; d=50,1 ; s=1,5
22	43.05.91	complessivo carter fisso alce 2300
	43.07.80	complessivo carter fisso alce 2500
	43.08.75	complessivo carter fisso alce 2700
23	49.04.95	perno protezioni anteriori alce 2300
	49.04.94	perno protezioni anteriori alce 2500
	49.04.93	perno protezioni anteriori alce 2700
24	41.07.22	protezioni anteriori L=90
	41.00.87	protezioni anteriori L=139
25	43.03.99	piede di appoggio
26	43.04.91	spina piede di appoggio
28	43.08.18	lamiera di usura telaio alce 2300 L=2265 ; s=2,5
	43.08.19	lamiera di usura telaio alce 2500 L=2445 ; s=2,5
	43.08.83	lamiera di usura telaio alce 2700 L=2625 ; s=2,5
29	01.1.101	vite TE M12x1,25 L=25 tf UNI 5740
30	02.5.002	dado metabloc M12x1,25 h=11
31	04.1.005	rosetta comune cat.C d 16 (17x35x3)
32	43.05.45	aletta direzionale dx con asola
33	43.05.47	aletta direzionale sx con asola
34	01.0.154	vite TE M10 L=25 tf zincata UNI 5739
35	02.2.002	dado autobloccante M10 h=12,3 UNI 7473
36	04.1.233	rosetta UNI 6593 cat.C d 10 (11x30x2,5) zincata
37	43.00.83	coltello tipo 02 dritto
38	43.01.44	distanziale coltello tipo 02
39	43.08.39	controcoltello per coltelli tipo 02 L=2275 alce 2300
	43.08.40	controcoltello per coltelli tipo 02 L=2455 alce 2500

Tav. 343 07 96			Alce 2300 - 2500 - 2700 U.S.A.
Pos.	Codice	Denominazione	
39	43.08.80	controcoltello per coltelli tipo 02 L=2635 alce 2700	
40	43.05.88	controcoltello liscio L=2275 alce 2300	
	41.09.26	controcoltello liscio L=2455 alce 2500	
	41.04.52	controcoltello liscio L=2635 alce 2700	
41	43.07.66	coltello tipo 05	
42	43.02.51	martello stampato	
43	43.08.53	coltello di ventilazione	
44	43.00.39	slitta dx	
45	43.00.40	slitta sx	
46	90.2.050	moltiplicatore TL311 L=1060 pto 540 g/min alce 2300	
	90.2.037	moltiplicatore TL311 L=1140 pto 540 g/min alce 2500	
	90.2.040	moltiplicatore TL312 L=1350 pto 1000 g/min alce 2700 di serie	
	90.2.047	moltiplicatore TL312 L=1350 pto 540 g/min alce 2700 a richiesta	
47	08.2.007	puleggia SPB 280/4 VIBIK (foro d=80) alce 2300-2500	
	08.2.018	puleggia SPB 250/4 VIBIK (foro d=80) alce 2700	
48	08.2.013	puleggia SPB 180/4 VIBIK (foro d=80) alce 2300-2500	
	08.2.028	puleggia SPB 212/4 VIBIK (foro d=80) alce 2700	
49	08.1.004	cinghia SPB 1750	
50	08.3.004	calettatore VK 156 (40 X 80)	
51	08.3.005	calettatore VK 156 (45 X 80)	
52	06.4.004	supporto flangiato con cuscinetto UCF 210	
53	10.0.501	protezione pto in plastica	
54	01.0.126	vite TE M 8 L=14 tf zincata UNI 5739	
56	01.0.204	vite TE M12 L=30 tf UNI 5739 alce 2300-2500	
	01.0.301	vite TE M16 L=30 tf UNI 5739 alce 2700	
57	01.0.205	vite TE M12 L=35 tf UNI 5739 alce 2300-2500	
	01.0.302	vite TE M16 L=35 tf UNI 5739 alce 2700	
58	01.1.102	vite TE M12x1,25 L=30 tf UNI 5740	
60	01.0.303	vite TE M16 L=40 tf UNI 5739	
61	01.0.309	vite TE M16 L=100 tf UNI 5739	
62	01.0.310	vite TE M16 L=110 tf UNI 5739	
63	01.1.204	vite TE M16x1,5 L=45 tf UNI 5740	
64	01.1.252	vite TE M18x1,5 L=50 tf UNI 5740	
67	01.4.003	vite TTQS M12 L=35 UNI 5732 con dado esagonale	
68	02.2.005	dado autobloccante M16 h=18 UNI 7473	
69	02.0.005	dado esagonale alto M16 h=16 UNI 5587	
70	02.4.005	dado metalbloc M16 h=14	
71	02.5.006	dado metalbloc M18x1,5 h=17	
72	09.2.501	ingrassatore dritto a spillo M 6	
73	05.2.102	spina elastica tipo pesante d 8 L=50 UNI 6873	
74	05.3.004	copiglia d 4 L=30 UNI 1336	
75	05.3.012	copiglia d 5 L=40 UNI 1336	
76	05.3.204	copiglia a molla d 3 L=61 art.112	
77	05.3.203	copiglia a molla d 5 L=100 art.116	
78	04.0.004	grower serie pesante d 12	
79	04.0.006	grower serie pesante d 16	
80	04.1.207	rosetta UNI 6592 cat.A d 12 (13x24x2,5) alce 2300-2500	
81	04.1.202	rosetta UNI 6592 cat.A d 16 (17x30x3)	
82	04.1.226	rosetta UNI 6593 cat.C d 8 (9x24x2) zincata	
83	04.1.232	rosetta UNI 6593 cat.C d 12 (14x36x3) alce 2300-2500	
	04.1.005	rosetta comune cat.C d 16 (17x35x3) alce 2700	
84	04.1.227	rosetta UNI 6593 cat.C d 16 (18x48x4)	
86	01.1.153	vite TE M14x1,5 L=40 tf UNI 5740	
87	02.5.003	dado metalbloc M14x1,5 h=12	

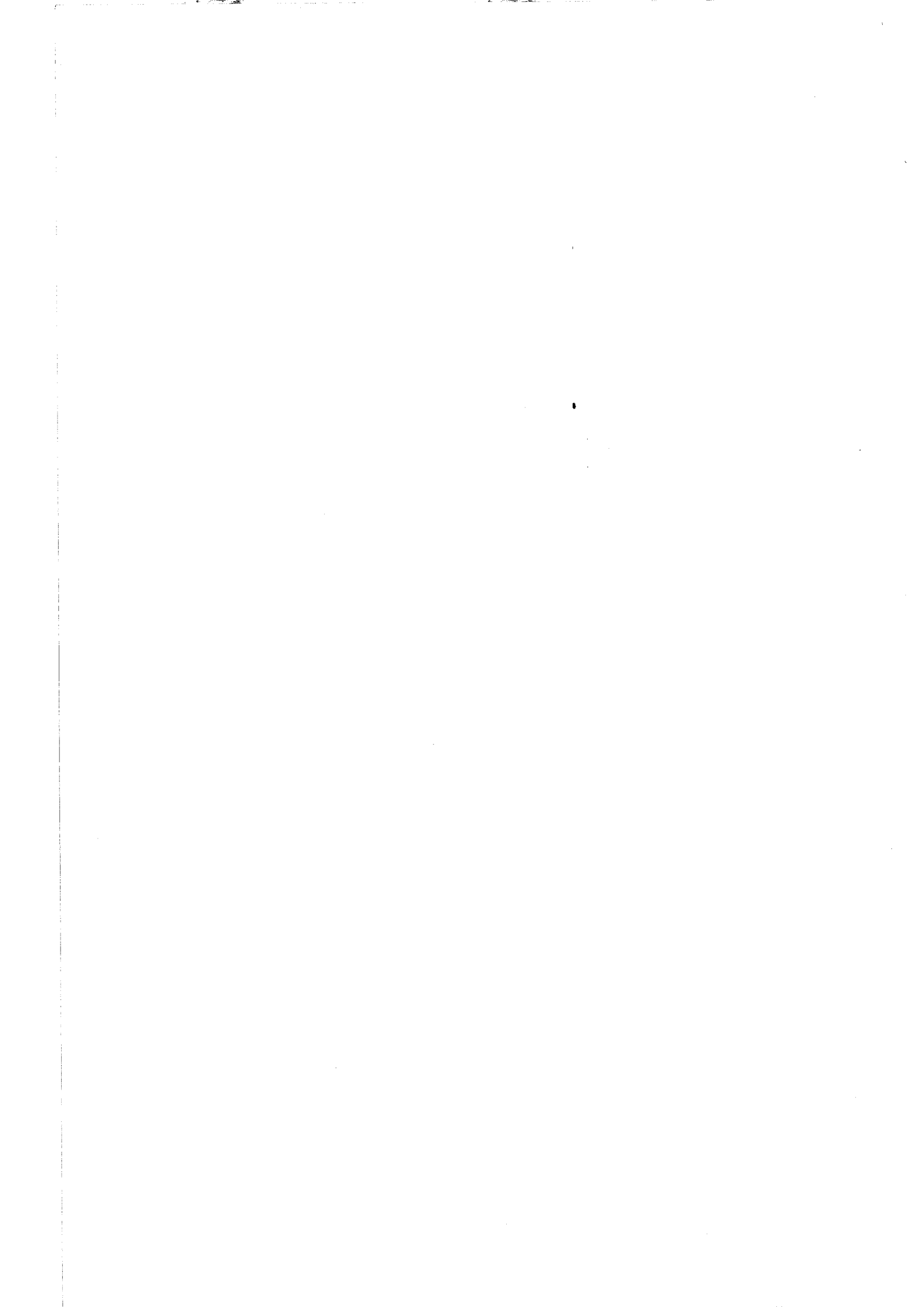

OPERATING INSTRUCTIONS

(Inglese) (cod. 2011 11/94)

1. GENERAL INFORMATION AND CODING DATA

1.1. Manufacturer

FALC s.r.l.

- via Proventa n. 41 FAENZA (RAVENNA) ITALY
- tel. 0546 / 29050
- fax 0546 / 663986
- telex 550866 ZAMA I

1.2. C.E.

1.3. Series:

- ALCE SHREDDER
- SUPER ALCE SHREDDER
- SUPER ALCE AVANT SHREDDER
- TEX SHREDDER
- SAX SHREDDER
- COBRA SPECIAL SHREDDER
- ZENIT SHREDDER

1.4. INSTRUCTIONS ATTACHED TO THE MODELS :

1.5. SERIAL NUMBER :

N.B.:

THIS INSTRUCTION MANUAL MUST BE SUPPLIED WITH EACH UNIT OF THE ABOVE MENTIONED SERIES.

THE MACHINE OPERATOR IS OBLIGED TO READ IT IN ALL ITS PARTS IN ORDER TO UNDERSTAND THE MACHINE'S CORRECT OPERATION.

SAFETY NOTES AND NOTES OF PARTICULAR IMPORTANCE ARE HIGHLIGHTED IN BOLD

2. CONDITIONS OF USE

FALC shredders are built to be coupled to an ideal tractor provided with a 3-point hitch and a Cardan shaft transmission. The Alce, Super Alce, Super Alce Avant, Tex, Sax and Cobra Special shredder series, are used to shred the remains after maize, wheat, Soya bean, cotton, sunflower, artichokes, tobacco harvests, etc., to allow a better formation of the humus necessary for the soil fertility, for the elimination of parasites and to achieve the optimal condition that restores the land for further cultivation. The Sax and Cobra Special shredder series are also used to shred grasses and pruning remains in fruit orchards and vineyards.

Every other use of the shredders is to be considered illegal and prohibited by the manufacturer.

To prevent toppling risks, the tractor to be linked to the shredder must be chosen taking into account the weight of the apparatus (kg) and of the distance of the centre line of the pins from the 3rd point from the centre of gravity of the shredding machine itself (Xg) (see point 4.3.2.). The tractors must moreover be chosen with a power to suit the shredder's size. The tractor's power values recommended by FALC are the following:

Model	Hp	Kw
• Alce 1250	35-70	26-52
• Alce 1600-1950-2300-2500	50-80	37-59
• Alce 2700-3200	70-120	52-88
• Super Alce 2500	60-120	44-88
• Super Alce 2700-3200-3200DT	70-140	52-103
• Super Alce 4000DT/M-4200DT/2 4700DT/2-4800DT/M	100-160	74-118
• Super Alce 6400DT/2	120-180	88-133
• Tex	50-100	37-74
• Sax	50-90	37-66
• Cobra Special 1350-1500	20-50	15-37
• Cobra Special 1800-2100	40-50	30-37

IT IS ABSOLUTELY FORBIDDEN TO ALLOW PERSONS, ANIMALS OR THINGS TO CLIMB OR BE TRANSPORTED ON THE SHREDDERS OF THE ALCE, SUPER ALCE, SUPER ALCE AVANT, TEX, SAX AND COBRA SPECIAL SERIES.

2.1. USE WITH THE REAR LID OPEN.

The Alce, Super Alce, Super Alce Avant series, for particular needs of the user, provides for the removal of the rear lid thus obtaining a distribution of the shredded material up to about 20 m from the shredder itself. (**fig.5**). Working in this particular situation requires some precautions on behalf of the operator even during the preparation phase of the shredder. The operator must act as follows:

- a) (If the machine is on) Completely stop the shredder and switch the tractor off. Wait for 60 - 120 secs, until the rotor is completely still.
- b) Unscrew the relative rear lid fixing bolts with the appropriate keys.
- c) In the Alce series, remove the lid.

- d) In the Super Alce series, place the lid in the new position and fix it with the relative bolts.
- e) If it is deemed necessary, mount the guide flaps in their positions.
- f) **Carefully check against the possibility that propelling material might be cast towards persons, animals or objects where this could cause damage (e.g. trees of a nearby farm, agricultural sheds, various parked vehicles, etc.). The minimum distance required between the shredder in operation and the nearest persons, animals or things, must be at least 50 m.**
- g) After the operator has carried out all these procedures, he can again climb onto the tractor and switch it on.
- h) **During operation with the rear lid open, the operator must ensure that the conditions mentioned in point (f) are constantly adhered to. The operator, must further ensure that the minimum distance between the shredder and any passage place, namely a street, a trail, etc., is at least 50 m.**
- i) **Even if only one of the above mentioned conditions is not adhered to, the operator is obliged to stop the shredder and switch the tractor off.**
- j) **It is further prohibited for the operator to leave the tractor's driver's position without having previously stopped the shredder and waited until the rotating parts of the same have come to a complete standstill (see point 3).**

2.2. SAX - TEX : FRONT USE

The Sax series (with 3rd mobile point) and Tex shredders are also predisposed to be connected to the front of the tractor.

SAX : The Sax series is provided with the lower double 3-point hitch as basic supply. In order to have the front coupling, the upper hitch must be slipped out of its housing (see **fig.17 pos. A**) and be reassembled on the opposite side (see **fig.18 pos.B**) taking care to precisely fix the reference dowels with the appropriate split pins.

TEX : To achieve a front coupling, it is necessary to carry out the following operations: (see **fig.16**)

- a) unscrew the bolts in **pos.B** with the appropriate keys
- b) dismantle the bracing in **pos.A**
- c) position the bracing **pos.A** in correspondence of the relative holes on the rear part of the machine (**pos.C**)
- d) fix the bracing in the new configuration by means of the relative bolts.
- e) dismantle the lower hitches of the 3rd point (**pos.E**) through the appropriate bolts
- f) reassemble the lower hitches on the rear pipe (**pos.F**) taking great care to fix them properly

N.B.: It is possible to mount the front as well as the rear hitch on the machine simultaneously. In this case, no operation is to be carried out on the 3rd point for frontal use.

Both the Sax and the Tex series are provided with overdrives having a through Power Take-off. **Rotation** of the overdrive becomes necessary if, when working with the shredder in front of the tractor, the rotation direction of the Power Take-off is inverted with respect to the usual.

To decide whether it is necessary to carry out the rotation of the overdrive, it is recommended to always verify the rotation direction of the Power Take-off.

To rotate the overdrive by 180°, the following operations must be carried out (see **fig.19**):

- a) dismantle the belts' safety guard (**pos.1**)
- b) loosen the bolts **pos.2-3**

- c) reduce the belts' tension by unscrewing the adjustment bolts **pos.4-5**
- d) slip the belts out of the pulley's races
- e) completely unscrew the bolt **pos.5** and remove the bolts **pos.3**
- f) completely unscrew the bolts **pos.6**
- g) move the box support **pos.7**
- h) rotate the overdrive by 180°
- i) reassemble support pos.7 on the overdrive by means of bolts **pos.6**
- j) insert bolts **pos.3** and the adjustment bolt **pos.5**
- k) position the belts in the pulley's races
- l) tension up the belts once more by screwing in bolts **pos.4-5**
- m) having reached the correct tension on the belts, tighten bolts **pos.2-3** (The correct tension of the belts is achieved when, by pushing on the central point between the pulleys, the belt yields to measure 10 mm from the straight line)
- n) tighten the adjustment screws **pos.4-5** with the appropriate nuts and conternuts
- o) mount the belts' safety guard **pos.1** and fix it tightly with the relative nut.

2.3. SUPPORTED VERSION - TRAILED VERSION

All the shredders are predisposed as supported machines, that is, the 3rd point of the machine is rigidly connected to the tractor's arms. In this case, the rear wheels of the Alce and Super Alce series, must absolutely be left oscillating during operation. The pin which is used to block the wheel in transport conditions must be removed and positioned in the relative housing provided on the machine. If the shredder is supplied in the trailed version, that is, with front drawbar, the rear wheels in the Alce and Super Alce series, must be blocked with the relative dowel in a perpendicular position to the frame of the machine itself.

3. CONDITIONS FOR THE OPERATOR

- 3.1. During the use of the shredder, the operator must remain on the tractor in the driver's position. **The operator cannot leave the driver's position on the tractor if he hasn't disengaged the power take-off from the tractor itself and has not waited until the moving parts of the shredder (rotor, etc.) are completely stationary.** The stop time of the moving parts of the various shredder models varies from a minimum of 30 secs to a maximum of 120 secs.
- 3.2. In normal conditions, that is, with the rear lid closed, the operator must ensure that when starting up the shredder and during its operation, there are no persons within a radius of 20 m around the machine. **The operator must immediately stop the tractor as well as the shredder if one or more persons enter within a 20 m radius around the machine.**
- 3.3. The operator must not activate the hydraulic lift of the tractor without having first disengaged the tractor's power take-off **Before lifting the shredding machine from the ground using the tractor's hydraulic lift, the operator must ensure that the power take-off is disengaged.**

4. INSTRUCTIONS TO CARRY OUT THE FOLLOWING OPERATIONS WITHOUT ANY RISK

4.1. SETTING UP THE SHREDDER

4.1.1. Connection of the Falc shredder to the tractor:

All Falc shredders can be mounted onto any type of tractor provided it is supplied with a 3-point universal hitch. **During the connecting phase, the tractor must be positioned on level ground, with the engine off and the handbrake on. It is forbidden to all persons to stay on the tractor until the connection phase is fully carried out.** The following, are necessary precautions for a correct connection of the Falc shredders to the tractor:

- a) **(fig.1)** Verify that the supporting leg (A) allows the machine to take up a perfectly horizontal position with respect to the ground.
- b) **(fig.2)** Provide for the connection of the 3rd point of the shredder with the tractor arms by means of the relative dowels. Block these with the split pins supplied.
- c) **(fig.3)** Connect the tractor's power take-off and that of the shredder's transmission box with the protected Cardan joint, taking care not to exceed a 30° offset. (this condition must be respected in every use situation of the shredder). Furthermore, ensure that the Cardan shaft has locked onto the 2 power take-offs.
- d) **(fig.3)** When mounting the Cardan shaft check that the two parts of the same are coupled for at least 1/3 of the length of the Cardan shaft itself in the most offset position. After having carried out these steps, the operator can again climb onto the tractor and activate the hydraulic lift just enough to render the support leg (A) free to be completely lifted and locked with the pin (B).
- f) **ATTENTION** : For the standard series machines the maximum revolutions of the P.T.O. can be:
 - 550 for the Alce, Sax, Cobra Special series.
 - 1000 for the Alce 2700-3200, Super Alce, Super Alce Avant, Tex series.

4.1.2. Disconnection of the shredder from the tractor:

During the disconnection phase, the tractor must be positioned on level ground with the engine off and the handbrake on. It is forbidden to all persons to stay on the tractor until the disconnection operation has been fully carried out. The following, are necessary precautions for a correct disconnection of the Falc shredders from the tractor:

- a) Stop the tractor on level ground, activate the handbrake, turn the engine off and disconnect the power take-off.
- b) Wait for about 120 secs until all the moving parts of the shredder stop.
- c) Climb off the tractor and position the shredder's foot so that the machine is in a plane position.
- d) Ease the shredder on the ground activating the tractor's hydraulic lift.
- e) Disconnect the shredder from the 3-point hitch of the tractor first by sliding out the split pins that block the dowels and then by removing the pins themselves.
- f) Disconnect the Cardan joint from the tractor's power take-off and place it in the appropriate shredder support.
- g) Climb onto the tractor again and move it forward to completely free the tractor's arms from the 3rd point of the shredder.

4.2. USE OF THE SHREDDER

4.2.1. After having correctly connected the shredder to the tractor, the operator can start to work, remembering to respect the conditions mentioned in point 3 (point 2 if working with the lid open).

4.2.2. The tractor's advancement speed is independent from the shredder; it is up to the operator to judge and determine the best machine output depending on some factors, namely the tractor's power, height of the remains to be shredded, adjustment of the working height, etc..

4.3 TRANSPORT

4.3.1. During operation, the shredders of the Alce and Super Alce series rest on the wheels at the rear and are kept lifted by the tractor's hydraulic hitches' arms in the front (see **fig.2** and **fig.7/B**). Alternatively to the rear wheels, 2 side slides can be mounted, or a rear roller for the Alce 1600-1950-2300-2500-2700 series. The shredders of the Tex, Sax series with 3rd fixed point and Cobra Special rest on the roller at the rear and are kept lifted by the tractor's hydraulic hitches' arms in the front. Alternatively to the roller, on specific request, the Tex series can be supplied with a pair of tyre wheels. The Sax series shredders with 3rd mobile point rest on the roller at the rear and on 2 steel wheels in front (the 3rd point hence only performs the function of trailing the machine). In the Super Alce Avant series, the front part has the possibility of mounting swivelling wheels; the rear part rests on the 3-point hitch which in this case, naturally, is in front of the tractor (**fig.20**).

4.3.2. For the transport in non-operational conditions, the shredders are completely carried by the tractor. Dimension (Xg) represents the distance of the machine's centre of gravity from the centre line of the pins of the 3rd point (see **fig.2**). The weights are the following:

Model	Wheight (kg)	Xg (mm)
• Alce 1250	425	695
• Alce 1600	630	695
• Alce 1950	760	695
• Alce 2300	845	725
• Alce 2500	930	725
• Alce 2700	1050	725
• Alce 3200	1245	795
• Super Alce 2500	1135	815
• Super Alce 2700	1145	815
• Super Alce 3200	1450	815
• Super Alce 3200DT	1480	965
• Super Alce 4200DT	1960	780
• Super Alce 4700DT	2200	780
• Super Alce 4000DT/M	1950	850
• Super Alce 4800DT/M	2230	850
• Tex 2300	660	510
• Tex 2700	740	510
• Sax 1600	700	625

• Sax 1800	750	625
• Sax 2100	780	625
• Sax 1600-P	530	610
• Sax 1800-P	580	610
• Sax 2100-P	610	610
• Cobra Special 1350-F	265	470
• Cobra Special 1500-F	285	470
• Cobra Special 1800-F	310	470
• Cobra Special 2100-F	345	470
• Cobra Special 1350-P	305	700
• Cobra Special 1500-P	325	700
• Cobra Special 1800-P	365	700
• Cobra Special 2100-P	405	700

4.3.3. An easy-to-use and easy-to-install trailer and drawbar are available to transport (not on public roads) the Alce 3200 shredder and the Super Alce series. The machine series mentioned above, are predisposed with a number of holes on the sides into which the trailer and drawbar bases can be bolted. In working conditions the machine takes up a configuration similar to that shown on **fig.12**. If the 2 trailer wheels and the relative axle bar are deemed cumbersome, they can be dismantled during work. In transport conditions the machine takes up a configuration similar to that shown on **fig.13**. **The operator must ensure that the trailer and drawbar are always blocked with the appropriate pins, both in operating and transport conditions.**

4.3.4. When it is necessary to move the machine for loading, unloading or storage purposes, always make use of equipment to suit the machine weight (see 4.3.3.) and utilise the grips strategically positioned on the shredders.

4.4. ASSEMBLING AND DISMANTLING

4.4.1. Assembling and dismantling the pulleys

The pulleys are fixed on the relative shafts by means of a coupling similar to that shown on **fig.10**.

a) To dismantle the pulleys adhere to the following steps:

- Loosen the bolts (A) with the relative key
- Remove "x" no. of bolts (A) and insert them into the threaded holes (B) tightening in a uniform manner
- After a few turns of the bolts the pulley can easily be slipped out from the shaft

b) To assemble the pulleys adhere to the following steps

- Insert the coupling in the pulley's hole
- Connect it all to the shaft ensuring that the pulley is in the right position
- Tighten in a uniform manner the bolts (A) with the relative key
- **ATTENTION** : Tightening moment = 40 N/m (4,1 kg/m)

4.4.2. It can happen, for transport purposes that as a result of their size, it may be necessary to dismantle the side guards present on the Alce, Super Alce, Tex, Sax and Cobra Special series shredders. In this case the guards will be placed on the machines in a very evident manner, on which they should be reassembled; it will be

the consignee's responsibility to provide for their positioning. In order to correctly position the side guards simply consult the spares table applicable to the specific type of shredder. The guards are supplied complete with the nuts and bolts necessary for their fixing.

4.5. ADJUSTMENT

4.5.1. Adjustment of the working height

Before using the shredder it is necessary to take particular care in adjusting the height and the working position.

- a) (fig.9) The working height adjustment is carried out by moving the connection flanges of the wheels, of the slides and of the roller by one or more holes.
- b) The working height adjustment is correct when the cutters or the hammers skim the ground without actually touching it. If the rotating movements touch the ground due to an incorrect adjustment, the result will be a greater power consumption by the tractor and a faster wear rate of the same rotating movements.
- c) (fig.7/B) The machine must always be in a horizontal position with respect to the ground. (fig.7/A shows an incorrect adjustment of the working height)

4.5.2. Positioning the machine with respect to the tractor

The positioning operation must always be carried out with a stopped tractor and with the power take-off disengaged.

- a) **Alce 1600-1950-2700-3200; Super Alce 2500-3200-4200-4700-4800, Super Alce Avant, Sax USA** : These machines have a standard basic single and fixed position with respect to the tractor.
- b) **Alce 2300-2500- (fig.11)** : Two machine positions are available with respect to the tractor. The desired positioning is achieved by bolting the 3rd point arms respectively on supports (A) or on supports (B) provided on the shredder. The choice of one of the two positions depends exclusively on the operator's specific requirements. The standard series machines are produced with the 3rd point positioned in supports (A). On specific request, also the Alce 1600-1950 series can be predisposed with double positioning with respect to the tractor.
- c) **Super Alce 4000**: Two positions are available with respect to the tractor thanks to the predisposal of the machine with a double series of 3rd point hitches
- d) **Tex, Sax** (with fixed 3rd point): It is possible to position the machine with respect to the tractor by adjusting the three clips which make up the machine's 3rd point (see fig.14-15). Each clip is fixed to the machine's frame by means of four bolts. The standard series machine is supplied with the clips in a central position, that is, the axis of the overdrive shaft coincides with that of the 3rd point.
- e) **Sax, Cobra Special, Tex with hydraulic movement**: the machine is provided with an hydraulic cylinder, connected to the tractor's hydraulic circuit plant, which allows the operator to adjust the shredder's position directly from the driver's seat. Before starting up the hydraulic movement operation, the operator must check that there are no persons, animals or objects in the machine's working range. The hydraulic movement operation can be carried out only with a still tractor and with the power take-off disengaged. **It is severely prohibited to activate the hydraulic movement of the machine with the tractor in motion and with the power take-off engaged.**
- f) **Sax, Cobra Special with manual movement**: The machine's configuration is the same as that with hydraulic movement. In place of the cylinder is a rod with some reference

holes which is used to set the machine in the desired position. At the end of the movement operation it is compulsory to block the machine by means of the relative reference rod. **It is absolutely prohibited to manually move the machine with the tractor in motion and with the power take-off engaged.**

- g) Sax (with 3rd point fixed) special U.S.A. type:** these machines have a single and fixed position with respect to the tractor.

4.6. MAINTENANCE AND REPAIRS

Before approaching the machine to carry out any maintenance or repairs, it is compulsory to take some precautions:

- a)** Stop the tractor on level ground, activate the handbrake, turn the engine off and disengage the power take-off.
- b)** Wait for 120 secs until all moving parts of the shredder have stopped.
- c)** Climb off the tractor and position the shredder's foot so that the machine is level.
- d)** Rest the shredder on the ground by activating the tractor's hydraulic lift.
- e)** Disconnect the shredder from the 3-point hitch of the tractor.

After having carried out these operations the operator can approach the shredder in order to carry out maintenance and repairs

IT IS ABSOLUTELY PROHIBITED TO CARRY OUT MAINTENANCE AND REPAIR OPERATIONS IF THE SHREDDER IS CONNECTED TO THE TRACTOR. In case of specific maintenance or repair where it is necessary to lift the machine from the ground or turn it about, it is indispensable to use suitable equipment built for such purposes. It is always recommended to consult the area sales assistance or mechanical workshops ideally equipped.

The machines' weights are reported in point 4.3.2. of this instruction manual.

4.6.1. Maintenance

Even though all the shredders are delivered well greased and lubricated, hereafter is a list of rules which must strictly be adhered to, so as to obtain better results.

a) After the first hour of operation

- Check that all bolts and screws are correctly tightened.

b) Daily

- Check the oil level in the transmission box.
- Lubricate the Cardan joint (see the specific Instruction manual relative to the Cardan joint)

ATTENTION: the Cardan joint is in general supplied by FALC and is suitable for the effective power required for the tractor-shredder link-up. In case of replacement always use a Cardan joint with characteristics not inferior to those of the original Cardan shaft.

c) Every 8 hours of work (fig.8)

- Clean and grease the rotor supports (A) through the grease nipples (B)
- Grease with moderation feeding a little grease at a time.

d) Every 8 working hours (fig.8)

- Check the belts' tension so as to prevent premature wear of the belts themselves and the pulleys.

- The correct tension of the belts is achieved when, by pushing on the central point between the pulleys, the belt yields to measure a maximum of 10 mm from the straight line)
- e) Every 300 working hours**
 - Change the oil in the transmission box.
 - On delivery the transmission box is lubricated with Mobil Gear 634 SAE 140 oil.
- f)** If vibrations should be noted on the shredder, check for breakage or excessive wear of the cutters or of the hammers. If necessary immediately provide for a partial or total replacement of these, taking utmost care to maintain the balance of the rotor, that is, by replacing the broken cutters (hammers) and those diametrically opposite the broken ones.
- g)** Further check if the cutters are covered with residues or encrustation on the hammers or on the rotor. If this verifies, provide for immediate cleaning.
- h)** Prior to a period of inactivity, it is recommended to accurately clean the machine from remains accumulated during operation. During the period of inactivity, it is recommended to protect it from atmospheric agents and in case it is provided with tyre wheels, keep the same lifted from the ground.

4.6.2. Possible causes of inconveniences and relative interventions.

4.6.2.1. If the shredder vibrates in an evident manner

CAUSE:

- a)** Breakage of one or more cutters (hammers) which causes the rotor to lose its balance.
- b)** The bearings of the rotor's supports are worn.
- c)** Remains and encrustations are visible on the cutters (hammers) and/or the rotor.

INTERVENTIONS:

- a)** Replacement of the broken cutters (hammers) and of those diametrically opposite the broken ones.
- b)** Replacement of the supports.
- c)** Cleaning of the cutters (hammers), cleaning of the rotor.

4.6.2.2. If the rotor rotates at a speed lower than specified

CAUSE:

- a)** The belts have become loose.
- b)** Excessive wear of the belts and pulleys.

INTERVENTIONS:

- a)** Reset the correct tension of the belts.
- b)** Replace any worn parts.

4.6.2.3. An excessive wear of the cutters (hammers) is noted.

CAUSE:

- a)** The cutters (hammers) touch the ground during operation.

INTERVENTIONS:

- a)** Reset the machine's correct height from the ground.

4.6.3. Replacement of the belts.

Carry out the following operations to replace the belts:

- a) Remove the belts' safety guard
- b) In shredders with simple transmission loosen the 4 bolts that fix the shaft which sustains the pulley (**fig.19 pos.2**)
- c) In shredders with double transmission loosen the 8 bolts that fix the two supports of the upper transmission shaft
- d) In the series with simple transmission loosen the adjustment bolts located on the extremity of the overdrive extension and nearby the overdrive itself (for the Tex and Sax series see **fig.19 pos.4** and **pos.3**) In this manner, a movement of the pulley is obtained and consequently the tension of the belts is reduced.
- e) In the series with double transmission loosen the adjustment bolts located on the extremity of the upper transmission shaft. In this manner a movement of the pulley is obtained and consequently the tension of the belts is reduced.
- f) Slide the belts from their respective pulley's races and replace them with new ones. Carefully check that the new belts are the same as the old ones, both as regards the length as well as the type. FALC s.r.l. installs toothed belts type SPB on standard series machines.
- g) To place the belts in tension again, reset the adjustment bolts previously loosened. **The bolts must be adjusted in such a way that the upper pulley remains parallel and on the same plane as the lower pulley. If the upper pulley is in an incorrect position with respect to the lower one, the belts do not transmit the right power and will hence have a shorter life.**
- h) Check the tension of the belts (see point 4.6.1.b)
- i) Tighten the fixing bolts previously loosened (see points b-c)
- j) Remount the belts' safety guard.

4.6.4. Tires' pressure

Check periodically that the tires' pressure is = 3 atm.

FIG. 1

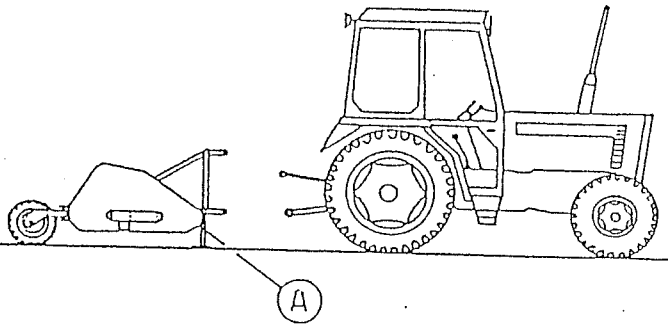

FIG. 2

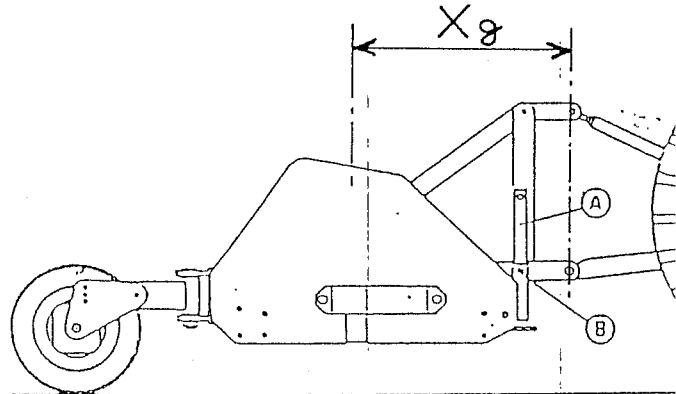

FIG. 3

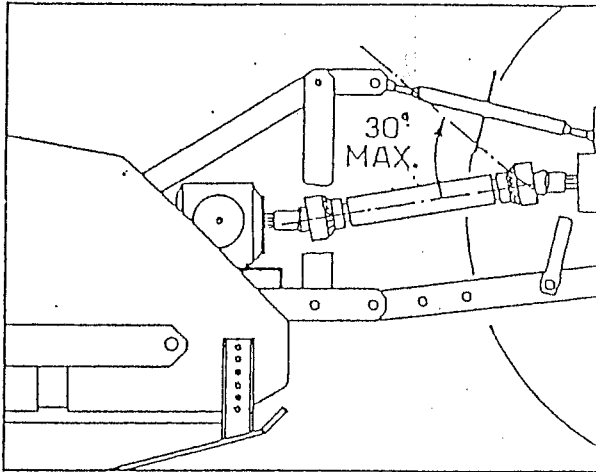

FIG. 4

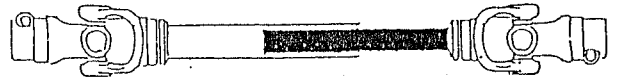

FIG. 5

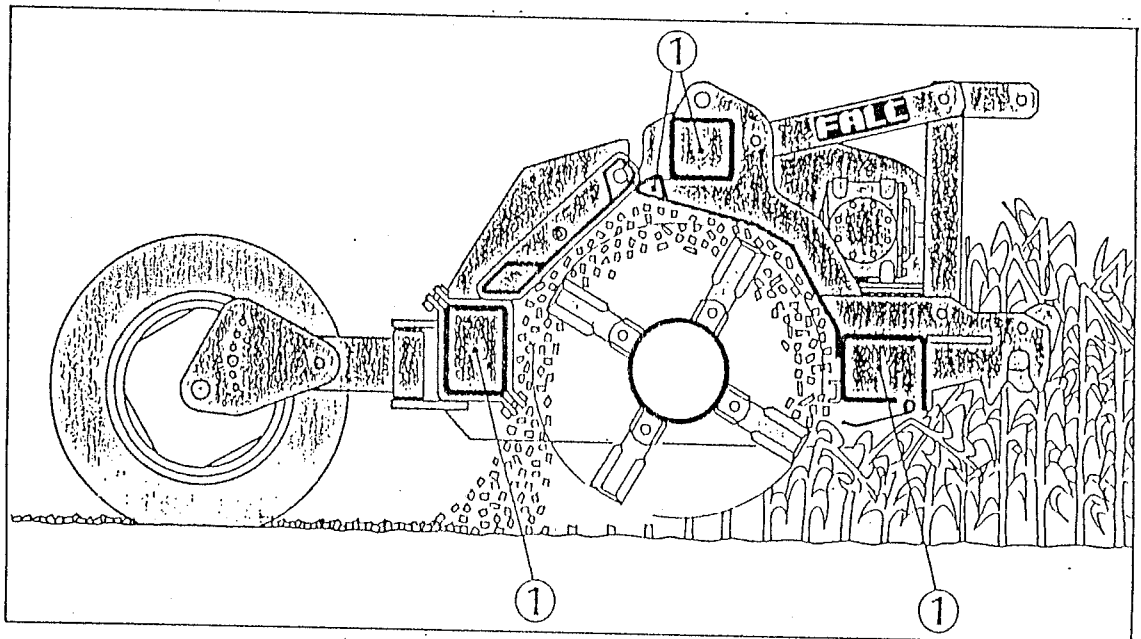

FIG. 6

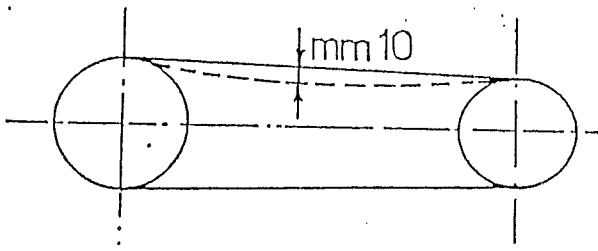

FIG. 7/A

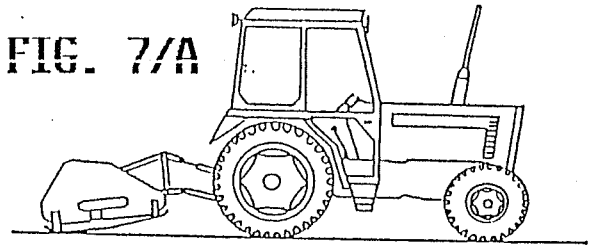

FIG. 7/B

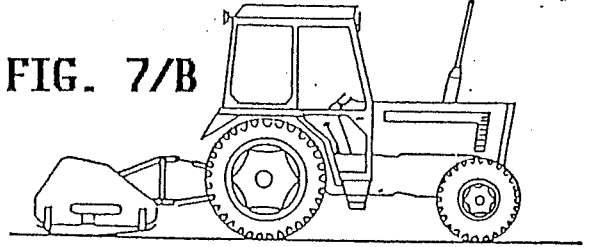

FIG. 8

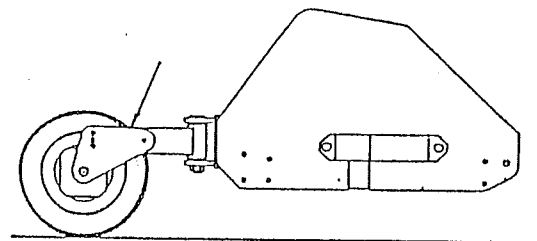
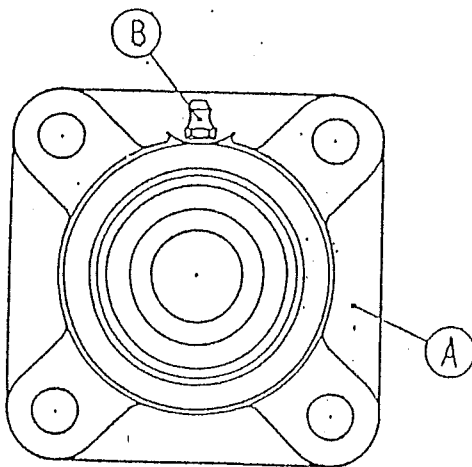

FIG. 9

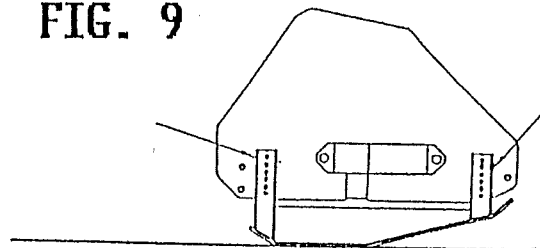

FIG. 10

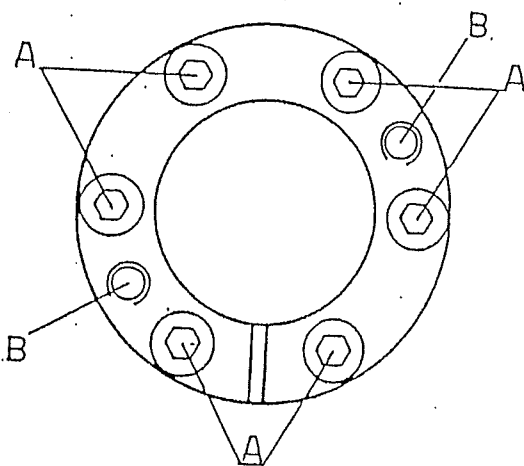

FIG. 11

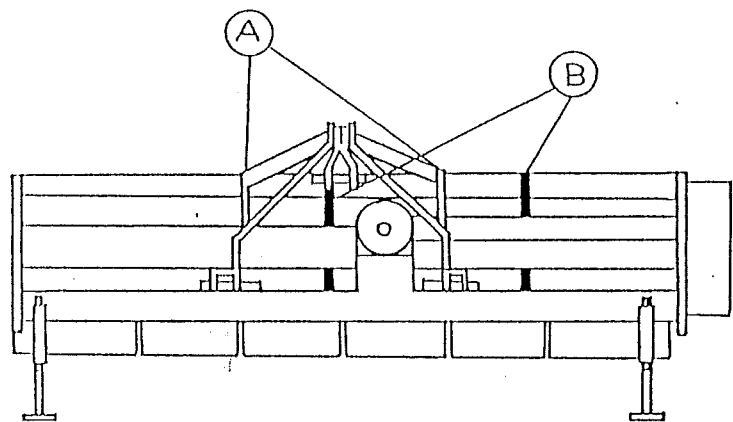

FIG. 12

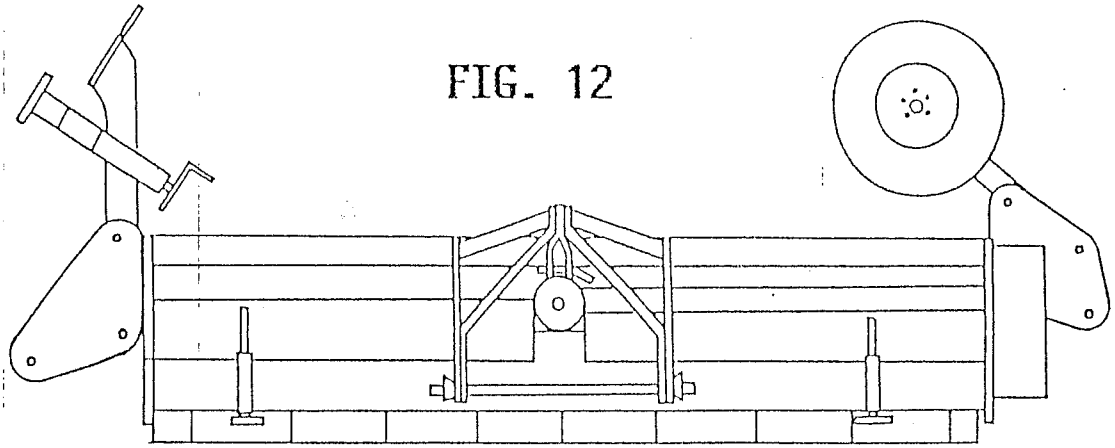

FIG. 13

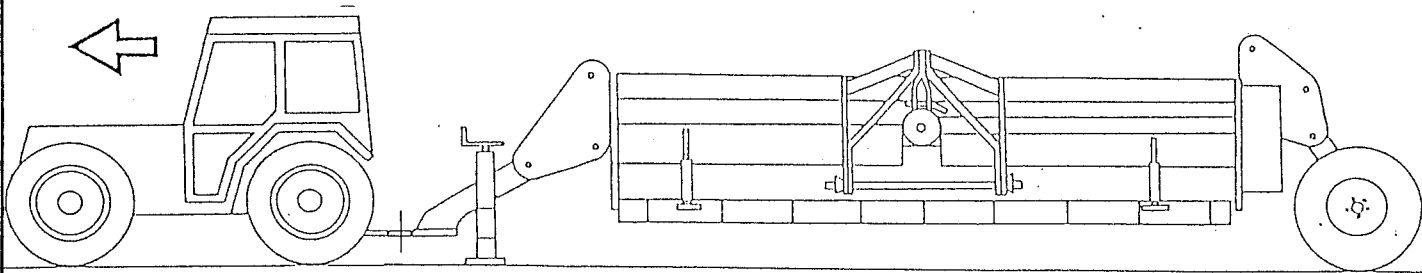

FIG. 14

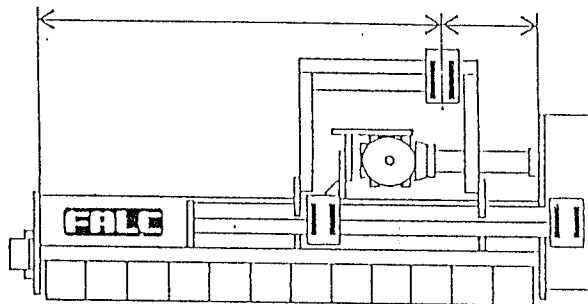

FIG. 15

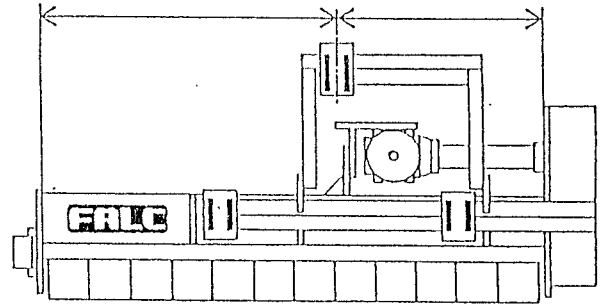

FIG. 16

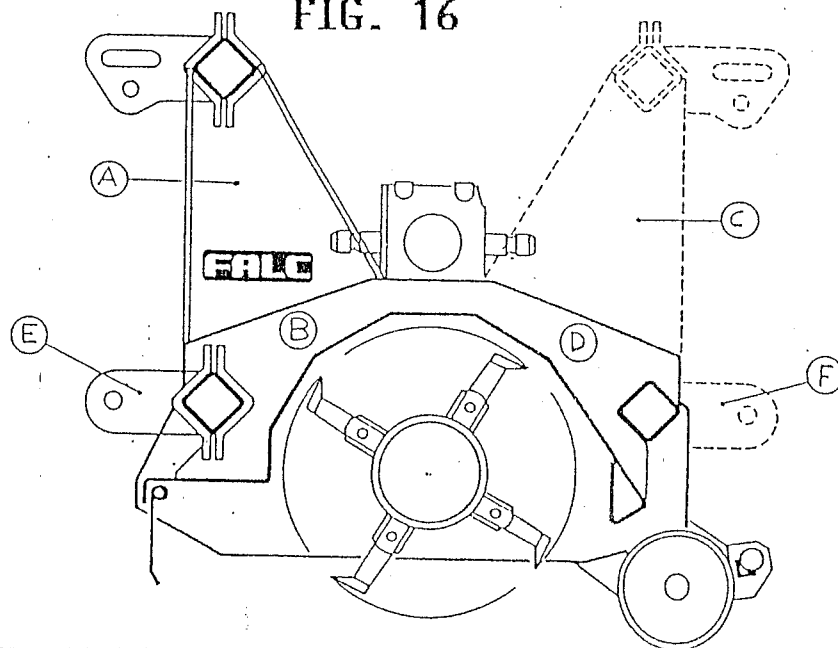

FIG. 17

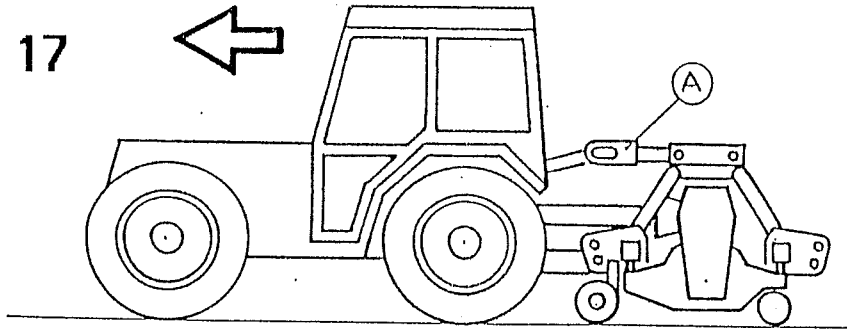

FIG. 18

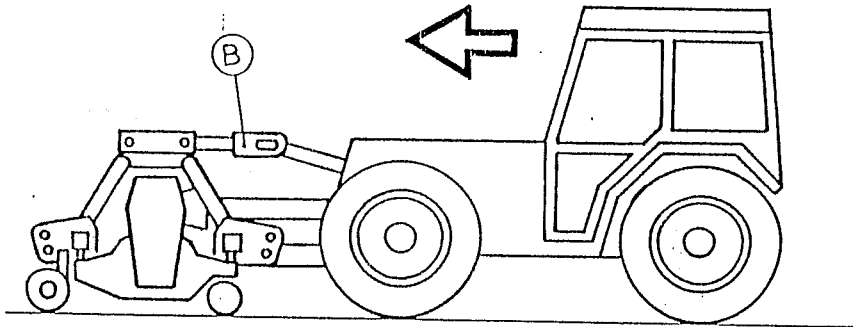

FIG. 19

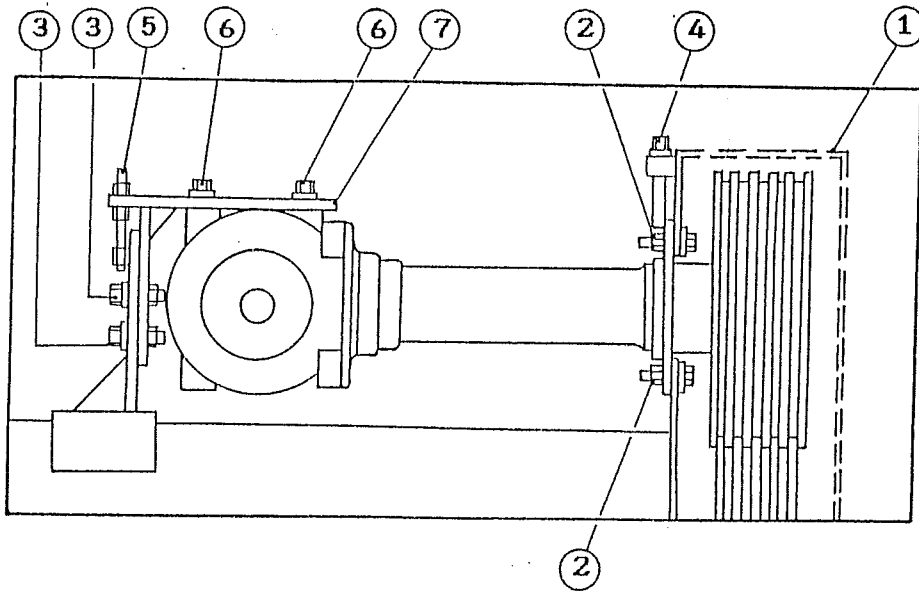
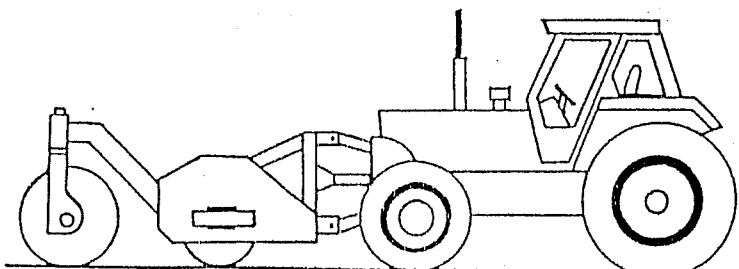

FIG. 20



5. WARRANTY

- 5.1.** Warranty period is fixed at 6 months from delivery. The company commits itself to replace parts which might present material or construction defects, in the least time possible. Labour time necessary for the replacement is excluded from the warranty. Transport and/or dispatch expenses are also excluded from the warranty.
- 5.2.** The buyer loses the warranty right if the faults are derived from force majeure, from an incorrect use of the machine or from any wrong action on behalf of the buyer, his employees or third parties. Repairs, replacements and modifications carried out or made to carry out by the buyer without the manufacturing company's authorisation are included among these actions. An incorrect use of the machine is the result of absence of adherence to the operating instructions listed in this manual.
- 5.3** Parts which due to their nature or function are subject to inevitable wear and tear or strain, are excluded from the warranty.
- 5.4** Bearings and oil seals are excluded from the warranty.
- 5.5** The Cardan shaft is excluded from the warranty
- 5.6** The following rules are applicable to the parts for which warranty is intended:
- a) the part to be replaced must be returned to the company on request of the new part.
 - b) the spare parts will always be invoiced on dispatch.
 - c) only the examination of the part on behalf of the manufacturing company's technicians could give the right to recognition of the warranty and hence a right to the credit.

6. RULES TO OBSERVE IN ORDERING SPARE PARTS CORRECTLY

To obtain a speedy dispatch of spare parts orders, it is necessary to specify:

- a) Machine type, Model, Serial Number.
(e.g. SHREDDER ALCE 3200 S.N. XXXXX)
- b) Spare parts table number where the part in question is located, Identification Number, Part code.
(e.g. Table no. YY, Detail no. JJ, Code KKKKKK)
- c) Exact name of the detail.
- d) Quantity of pieces requested.
- e) Dispatch instructions.
(by rail, parcel post, courier, etc.)
- f) **The minimum delivery time of the requested parts is 3 days from receipt of order**

7) SAFETY PICTOGRAMS

All the safety pictograms applied to Falc's machines, are based on norms ISO 11/684.

The adhesive labels adopted are 168 x 88 mm and are divided in two equal parts.

The left part contains within the triangular danger symbol the graphic description of the symbol itself.

e.g. Attention - Danger of flying objects.

The right part shows how to avoid the risk.

e.g. Maintain a safety distance.

Together, these 2 graphics synthesise the full message which is intended to be transmitted to all those which for various reasons are in direct contact or nearby a Falc-produced machine.

(see enclosure C of the norm)

The graphical message is hence directed to the machine operators as well as all those that enter within the working radius of the machine.

The operator is obliged to carefully read the machine's instruction manual in order to understand its correct operation and to have a comprehensive explanation of the safety pictograms

The complete list of all the pictograms which are applied to Falc-produced machines is reported hereafter with the relative explanation on the side.

Label no.1

ATTENTION : Read the instruction manual before using the machine.

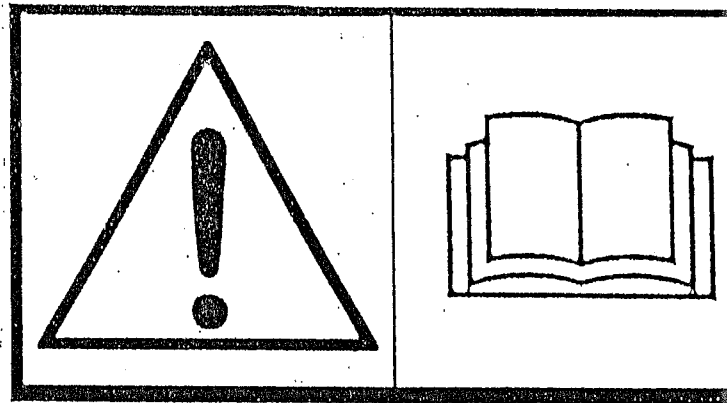

FALC FAENZA (RA) - ITALY - TEL. 0546/29050 - FAX 0546/550866

Label no.2

ATTENTION : Danger of hand and fingers collision with movements in alternate rotation.

Keep the safety distance.

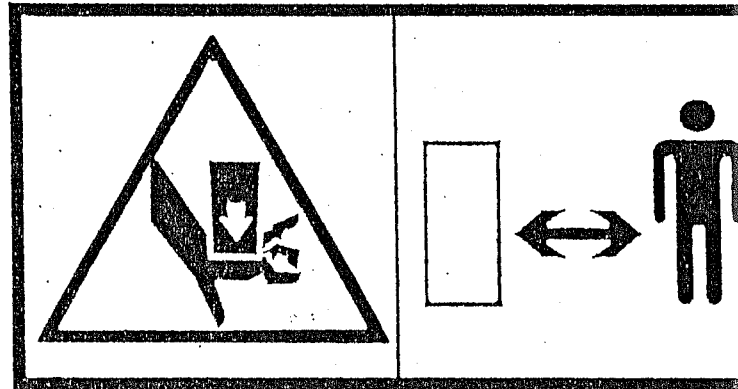

FALC FAENZA (RA) - ITALY - TEL. 0546/29050 - FAX 0546/550866

Label no3

ATTENTION : Danger of foot collision with movements in alternate rotation.

Keep the safety distance.

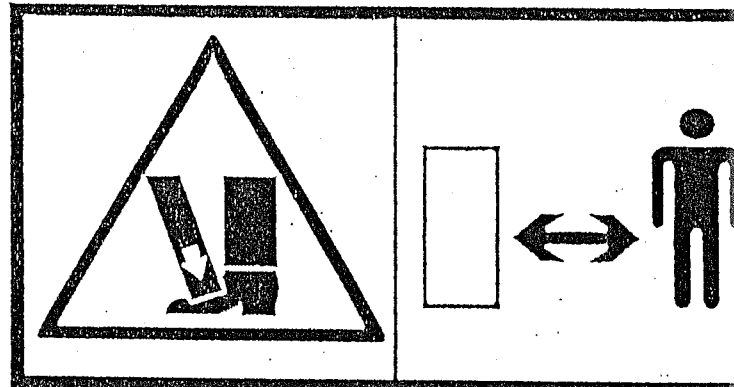

FALC FAENZA (RA) - ITALY - TEL. 0546/29050 - FAX 0546/550866

Label no.4

ATTENTION : Danger for feet due to rotating cutters with horizontal rotating axis.

Keep the safety distance.

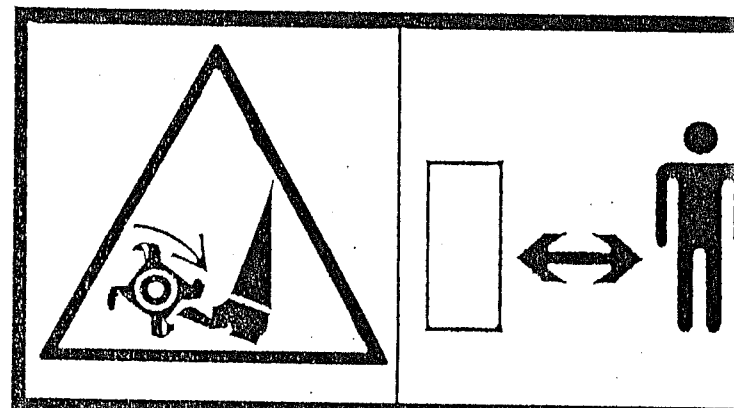

FALC FAENZA (RA) - ITALY - TEL. 0546/29050 - FAX 0546/550866

Label no.5

ATTENTION : Danger due to machine component that can be lifted from the ground.

Keep the safety distance.

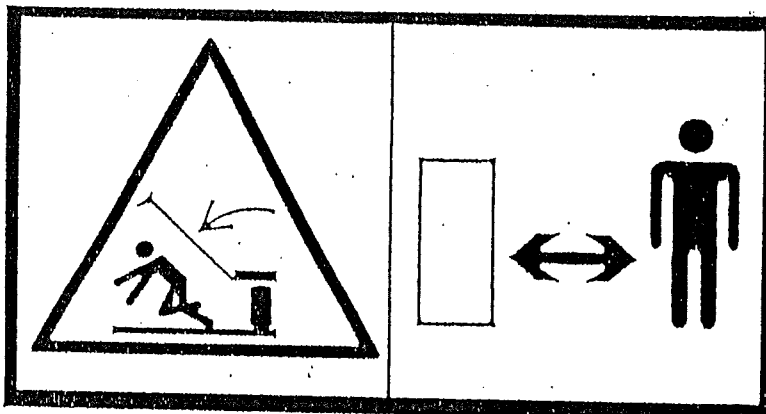

FALC FAENZA (RA) - ITALY - TEL. 0546/29050 - FAX 0546/550866

5

Label no.6

ATTENTION : Danger of cutting due to moving parts.

Wait until all moving components are completely still before approaching the machine.

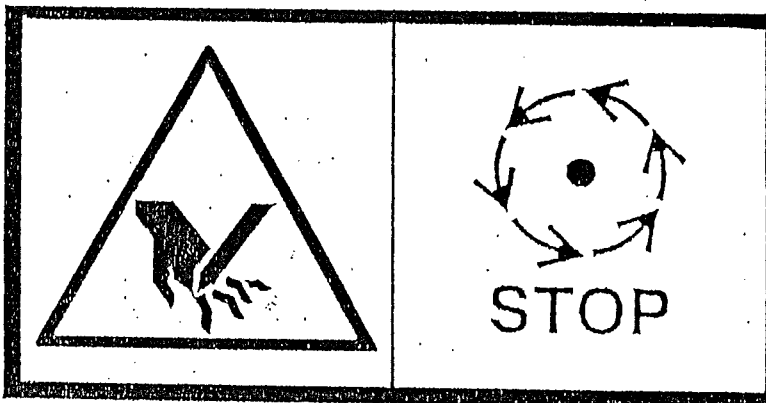

FALC FAENZA (RA) - ITALY - TEL. 0546/29050 - FAX 0546/550866

6

Label no.7

ATTENTION : Danger due to flying objects.

Keep the safety distance.

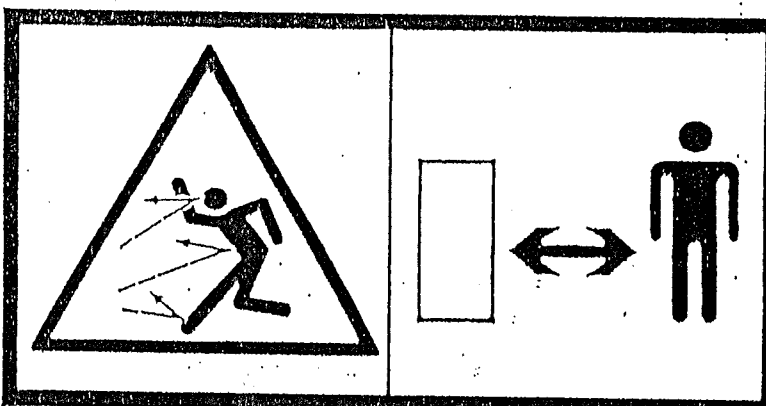

FALC FAENZA (RA) - ITALY - TEL. 0546/29050 - FAX 0546/550866

7

Label no.8

ATTENTION : Danger due to hot surfaces.

Keep the safety distance.

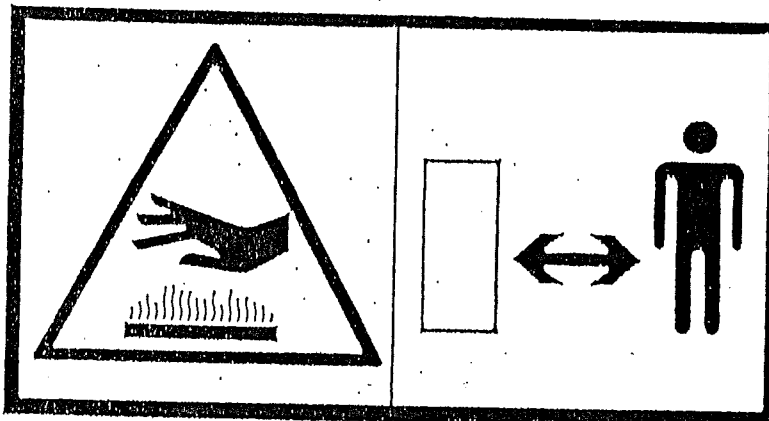

FALC FAENZA (RA) - ITALY - TEL. 0546/29050 - FAX 0546/550866

8

Label no.9

ATTENTION : Danger of hand and finger cutting.
Keep the safety distance.

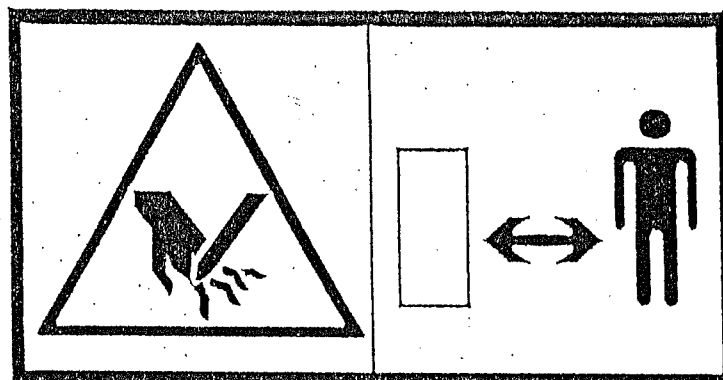

Label no.10

ATTENTION : Danger of feet cutting.
Maintain the safety distance.

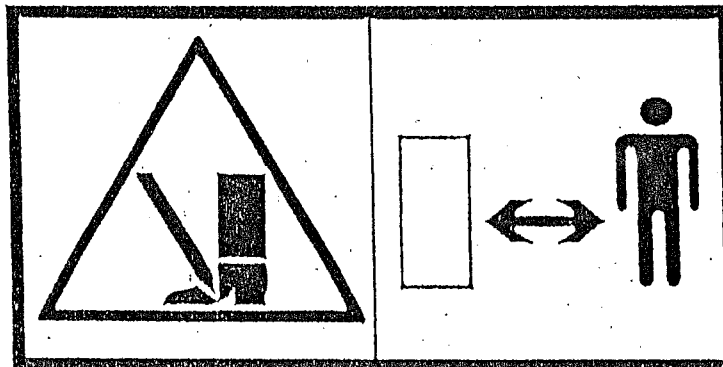

Label no.11

ATTENTION : Danger of rotating movements.
Do not open or remove the safety guards of the rotating shafts while the machine is in operation.

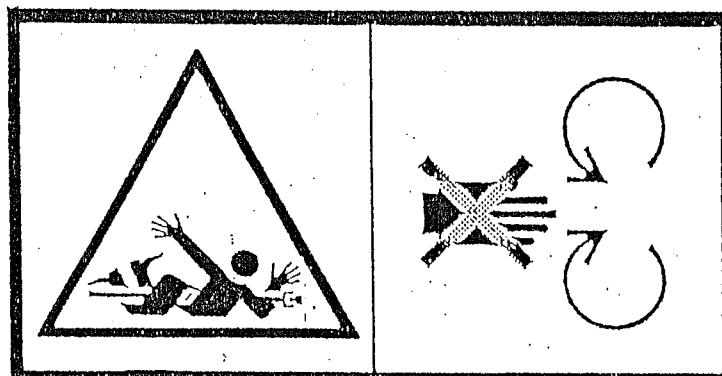

Label no.12

ATTENTION : Danger due to loads lifted from the ground.
Keep the safety distance.

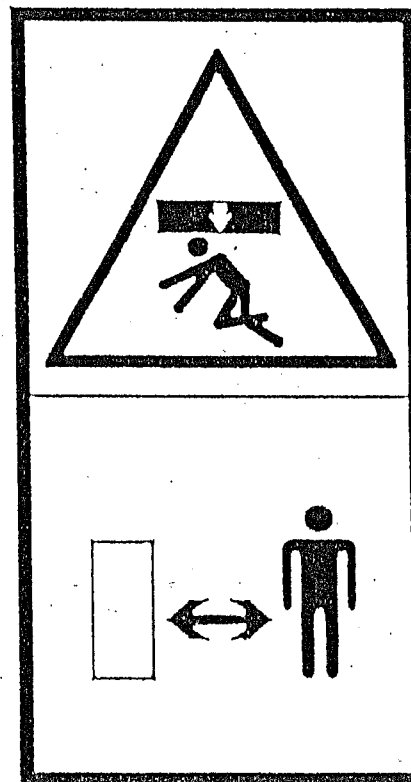

8. NOISE AND VIBRATIONS

- 8.1. Noise:** from various tests effected on the different models, the highest result of the LAeq (equivalent acoustic level) value has been of 85 dBA @ 800 r.p.m. of the Power Take-off on the Super Alce model provided with single rotor.
- 8.2. Vibrations:** No vibration values have been detected within the tractor's cabin.

IF ANY PART OF THIS INSTRUCTION MANUAL SHOULD RESULT INSUFFICIENTLY CLEAR, WE ASK YOU TO KINDLY CONTACT YOUR CLOSEST AUTHORISED DEALER OR CONTACT US DIRECTLY AT OUR TECHNICAL AND COMMERCIAL DEPARTMENTS.

INDEX

- 1. General information**
- 2. Conditions of use**
 - 2.1. Use with the rear lid open.
 - 2.2. Front use
 - 2.3. Supported Version - Trailed Version
- 3. Conditions for the operator**
- 4. Instructions to carry out the following operations without any risk**
 - 4.1. Setting up the shredder
 - 4.2. Use of the shredder
 - 4.3 Transport
 - 4.4. Assembling and dismantling
 - 4.5. Adjustment
 - 4.6. Maintenance and repairs
- 5. Warranty**
- 6. Rules to observe in ordering spare parts correctly**
- 7. Safety pictograms**
- 8. Noise and vibrations**

This handbook or any part of it cannot be reproduced, copied or published without prior written authorization of FALC.

FALC reserves the right to modify the here described specifications at any time without committing itself to update this handbook every time.

