



*Doing Our Best to Provide You the Best*

AP20005, Rev 14  
01/16

---

**LIL'THUMPER  
Piston Pump**

---

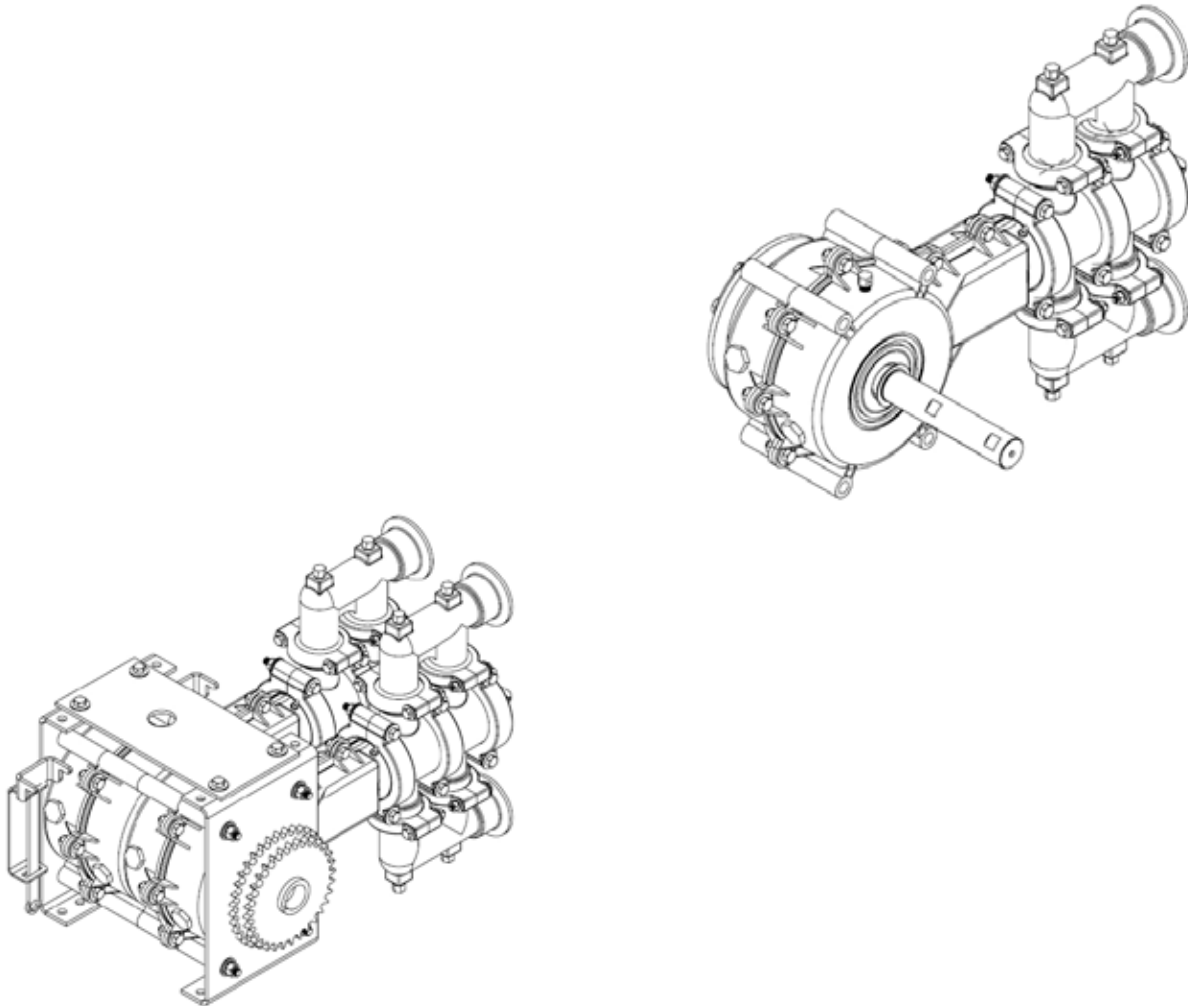

**OPERATOR MANUAL**

Thank you for purchasing a Demco Lil' Thumper pump. We feel you have made a wise choice and hope you are completely satisfied with your new pump. If you have any questions regarding the applications of certain solutions or chemicals, contact your chemical supplier and follow chemical manufacturer recommendations as well as all licensing and use restrictions or regulations.

## WARRANTY POLICY, OPERATOR MANUALS & REGISTRATION

Go online to [www.demco-products.com](http://www.demco-products.com) to review Demco warranty policies, operator manuals and register your Demco product.



**WARNING:** TO AVOID PERSONAL INJURY OR PROPERTY DAMAGE, OBSERVE FOLLOWING INSTRUCTIONS:

**Chemicals are dangerous. Know exactly what you're going to do and what is going to happen before attempting to work with these products. Improper selection or use can injure people, animals, plants and soil.**

**Always wear protective clothing such as coveralls, goggles and gloves when working with chemicals or sprayer.**

**Be sure to dispose of all unused chemicals or solutions in a proper and ecologically sound manner.**

## Return Procedures for Chemical Pumps or Related Items

All pumps or related items must be flushed of any chemical (ref. OSHA Section 0910.1200 (d)(e)(f)(g)(h) and hazardous chemicals must be labeled before being shipped to or carried into Demco for service or warranty consideration. Demco reserves the right to request a Material Safety Data Sheet from the Purchaser for any pump or related items Demco deems necessary. Demco reserves the right to "disposition as scrap" pumps or related items returned which contain unknown substances, or to charge for any and all costs incurred for chemical testing and proper disposal of components containing unknown substances. Demco request this in order to protect Demco personnel and the environment from the hazards of handling unknown substances.

## GENERAL INFORMATION

1. Unless otherwise specified, high-strength (grade5) (3 radial-line head markings) hex head bolts are used throughout assembly of this sprayer.
2. Whenever terms "**LEFT**" and "**RIGHT**" are used in this manual it means from a position behind sprayer and facing forward.
3. When placing a parts order, refer to this manual for proper part numbers and place order by **PART NO., DESCRIPTION, and COLOR.**

## Table of Contents

General information .....	2
Bolt Torque.....	3
Mounting the Pump and Lubrication Requirements .....	4
Rate Adjustment and Start-up Procedure .....	5
Suggested Plumbing .....	6
Single and Double Piston Parts Breakdown .....	7
Single and Double Piston Pump Parts List.....	8
Manual Clutch Parts Breakdown and Parts List .....	9
Piston Wiper Replacement .....	10 &11
Stackpack Replacement.....	12
Determining Sprocket Ratios For Piston Pumps .....	13
Routine Maintenance and Maintenance Record .....	14
Trouble Shooting and Pump Storage.....	15
Pump and Sprayer Checklist .....	16

# BOLT TORQUE

## TORQUE DATA FOR STANDARD NUTS, BOLTS, AND CAPSCREWS.

Tighten all bolts to torques specified in chart unless otherwise noted. Check tightness of bolts periodically, using bolt chart as guide. Replace hardware with same grade bolt.

NOTE: Unless otherwise specified, high-strength Grade 5 hex bolts are used throughout assembly of equipment.



### Torque Specifications

**Bolt Torque for Standard bolts \***

"A"	GRADE 2		GRADE 5		GRADE 8	
	lb-ft	(N.m)	lb-ft	(N.m)	lb-ft	(N.m)
1/4"	6	(8)	9	(12)	12	(16)
5/16"	10	(13)	18	(25)	25	(35)
3/8"	20	(27)	30	(40)	45	(60)
7/16"	30	(40)	50	(70)	80	(110)
1/2"	45	(60)	75	(100)	115	(155)
9/16"	70	(95)	115	(155)	165	(220)
5/8"	95	(130)	150	(200)	225	(300)
3/4"	165	(225)	290	(390)	400	(540)
7/8"	170	(230)	420	(570)	650	(880)
1"	225	(300)	630	(850)	970	(1310)

**Bolt Torque for Metric bolts \***

"A"	CLASS 8.8		CLASS 9.8		CLASS 10.9	
	lb-ft	(N.m)	lb-ft	(N.m)	lb-ft	(N.m)
6	9	(13)	10	(14)	13	(17)
7	15	(21)	18	(24)	21	(29)
8	23	(31)	25	(34)	31	(42)
10	45	(61)	50	(68)	61	(83)
12	78	(106)	88	(118)	106	(144)
14	125	(169)	140	(189)	170	(230)
16	194	(263)	216	(293)	263	(357)
18	268	(363)	--	--	364	(493)
20	378	(513)	--	--	515	(689)
22	516	(699)	--	--	702	(952)
24	654	(886)	--	--	890	(1206)

Torque figures indicated are valid for non-greased or non-oiled threads and heads unless otherwise specified. Therefore, do not grease or oil bolts or capscrews unless otherwise specified in this manual. When using locking elements, increase torque values by 5%.

\* GRADE or CLASS value for bolts and capscrews are identified by their head markings.

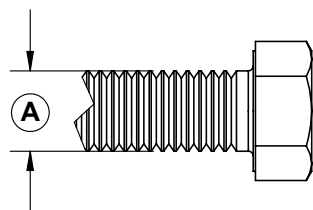

**GRADE-2**

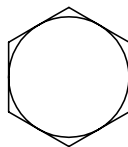

**GRADE-5**

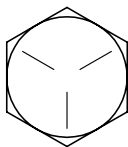

**GRADE-8**

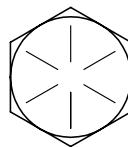

**CLASS 8.8**

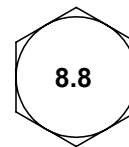

**CLASS 9.8**

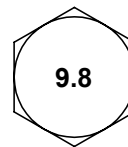

**CLASS 10.9**

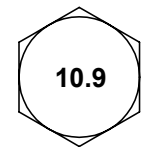

## SUGGESTED GROUND DRIVE MOUNTING

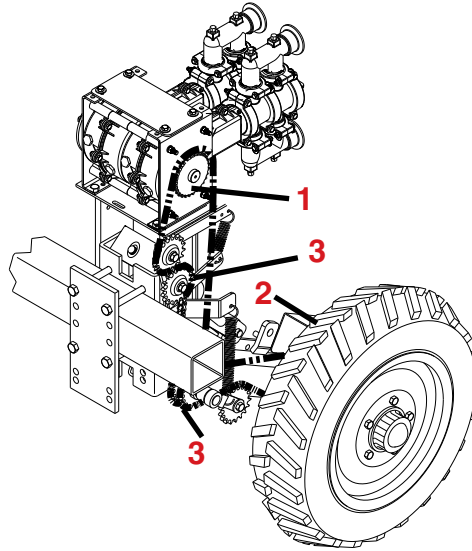

## MOUNTING THE PISTON PUMP

The Lil' Thumper pump should be mounted firmly to the implement so the pump is in a horizontal position when operating (as shown above). The drive sprocket (#1) on the pump and the ground wheel drive sprocket (#2) must be in line to prevent chain jumping and undue wear. There must be a spring loaded chain idler (#3) installed on the non-driven side of the chain. **The pump should be mounted as low as possible in relation to the tanks to facilitate priming.** The chain should be long enough so when the chain idler is loosened the chain can be slipped off the drive wheel sprocket when traveling to and from the field. **Damage may occur to the pump with chain on at speed of over 10 mph.**

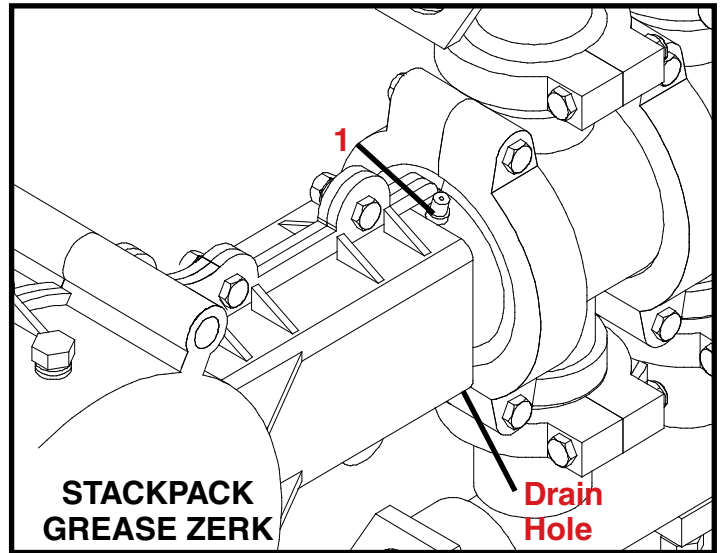
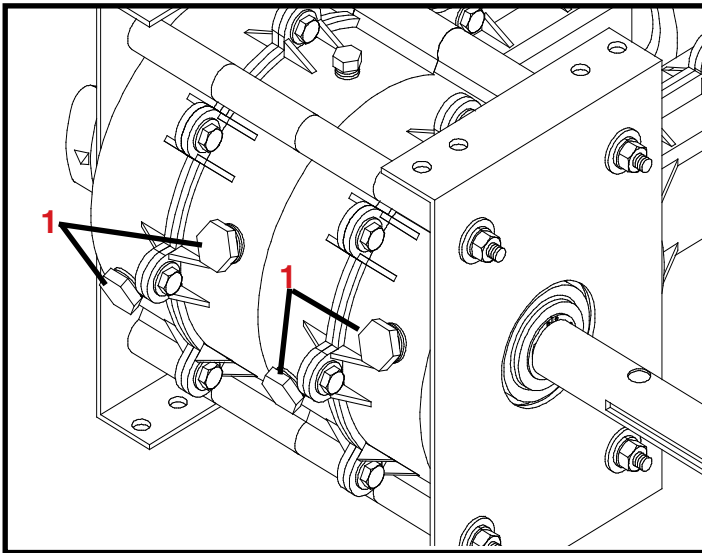

## LUBRICATION REQUIREMENTS

**Before using the pump, check the oil.** Remove the two 1/2" nylon filler plugs on PP1 and four 1/2" nylon filler plugs on PP2 (#1). Fill **each** drive case through the upper fill hole with a good quality 30 weight oil, non-detergent preferred if needed. Add oil until the oil level is even with the bottom edge of the lower fill hole (2/3 quart per drive case - approx. 21-1/2 oz.). A funnel with a hose on the neck (similar to the type used to fill automatic transmissions) will make this operation easier. Replace and tighten all fill plugs. Check the oil level at the start of each day of use and change oil seasonally.

The stackpack gland areas (located in the front of the necks of the pump) must be filled with a good quality grease. Cover the small drain hole at the bottom of the front of the pump neck **tightly** with your finger. Pump grease into the zerk fitting (#1) at the top of the pump neck until the pressure pushes the grease past your finger. Make sure zerks in both necks are sufficiently greased on the PP2. This puts grease around all stackpack surfaces and increases the life of the stackpack considerably. Repeat this procedure every six hours of use thereafter. Keep the holes at the bottom of the necks clear of dirt and other obstructions so that any fluid leaking past the front stackpack can drain out before it has a chance to enter the drive case.

**Grease these zerks and the zerks in the clutch castings at least once for each day of use.**

## RATE ADJUSTMENT

Application rate for the Lil' Thumper is determined by using the slide chart included with the pump. Complete instructions are on the back of the slide chart. Pump output is determined by the drive wheel loaded radius, sprocket ratios, and pump adjustment disc setting.

### TO SET THE PUMP APPLICATION RATE:

NOTE: Adjustment is made when drive chain is connected to drive wheel.

1. Loosen the two bolts holding the plated cast iron pointer (#1) to the adjustment disc (#2).
2. Insert one finger of the special adjusting wrench (#3) into the round hole in the numbered adjustment disc as shown. Turn the adjustment disc clockwise or counter clockwise to the desired setting. Pointer bolts need to be moved to center hole for minimum or maximum settings.
3. Retighten the two bolts holding the pointer to the adjustment disc.

Remember that the slide chart is based on spraying water. Because of variable factors such as differing solution weights, wheel slippage, etc. **ACTUAL FIELD CALIBRATION SHOULD BE DONE** to insure the desired rate being applied. Refer to the back of the slide chart for an example of proper tip selection. **NOTE: Remove the drive chain from the ground drive wheel when traveling to and from the field to prevent possible loss or damage to the chain.**

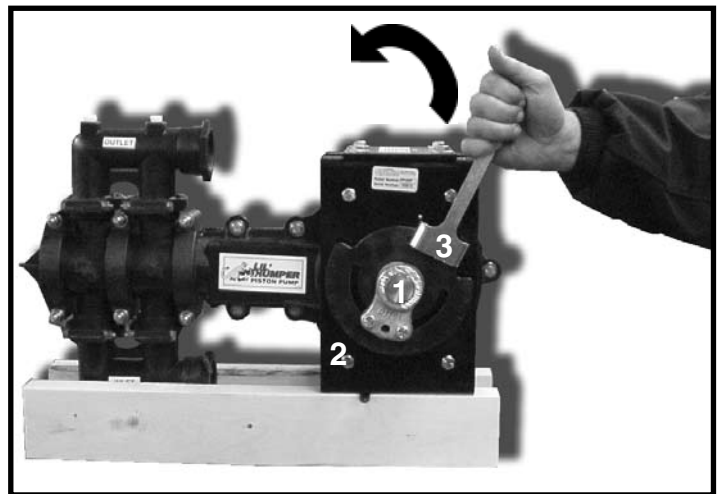
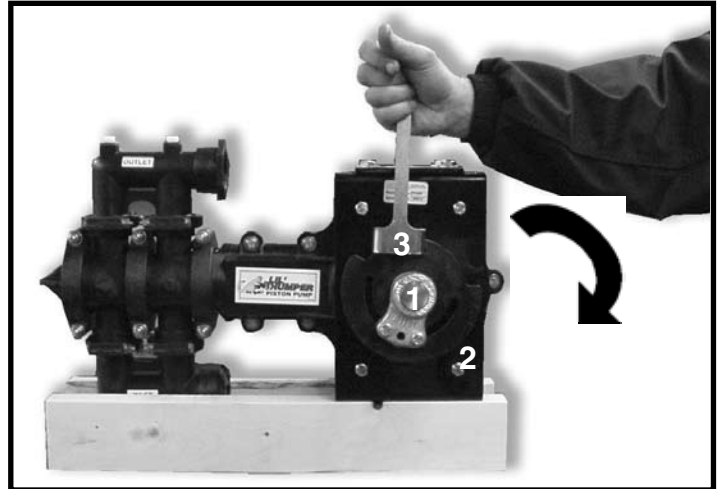

## START-UP PROCEDURE

Check the oil level as described in the "LUBRICATION" section of this manual. Fill tank 1/2 full of water to get loaded radius. Open the tank outlet valve and any other valves which would restrict the flow of liquid to, or from, the pump. Remove one of the plugs from the bottom of the inlet manifolds to see if the fluid is up that far and to remove any air locks. Put the plug back in when all the air escapes. The pump should prime itself after pulling the implement a few feet with the clutch engaged. **Important: The pump must not run more than 50 feet without fluid in it. If the pump fails to prime after trying the above procedure, remove the inlet manifold plugs to see if there is fluid to the inlet manifolds. If difficulty persists, refer to the "TROUBLE SHOOTING" section of this manual.**

If pump does not prime, it may be necessary to set the rate adjusting pointer to maximum and remove two spray nozzles (to prevent a high pressure build-up). Drive forward until the pump primes and begins pumping, replace the two spray nozzles, reset the pump, and check for any leaks resulting from loose fittings, hoses, etc. After all checks have been made, add chemical and water to fill the tank.

**Optimum Operating Pressure 20-40 PSI.**

**NOTICE!!!**

**This PUMP is SHIPPED  
WITH OIL**

**FILL EACH PUMP CAVITY WITH 2/3 QT. SAE-30  
NON-DETERGENT OIL or fill until oil comes out  
the check plug. On a Double Piston Pump (PP2),  
fill both sides of housing (requires 1-1/3 qt.).**

Rev 1

AP21002

## SUGGESTED PLUMBING FOR PISTON PUMP

NOTE: Thread sealant should be applied to all threaded fittings before assembly.

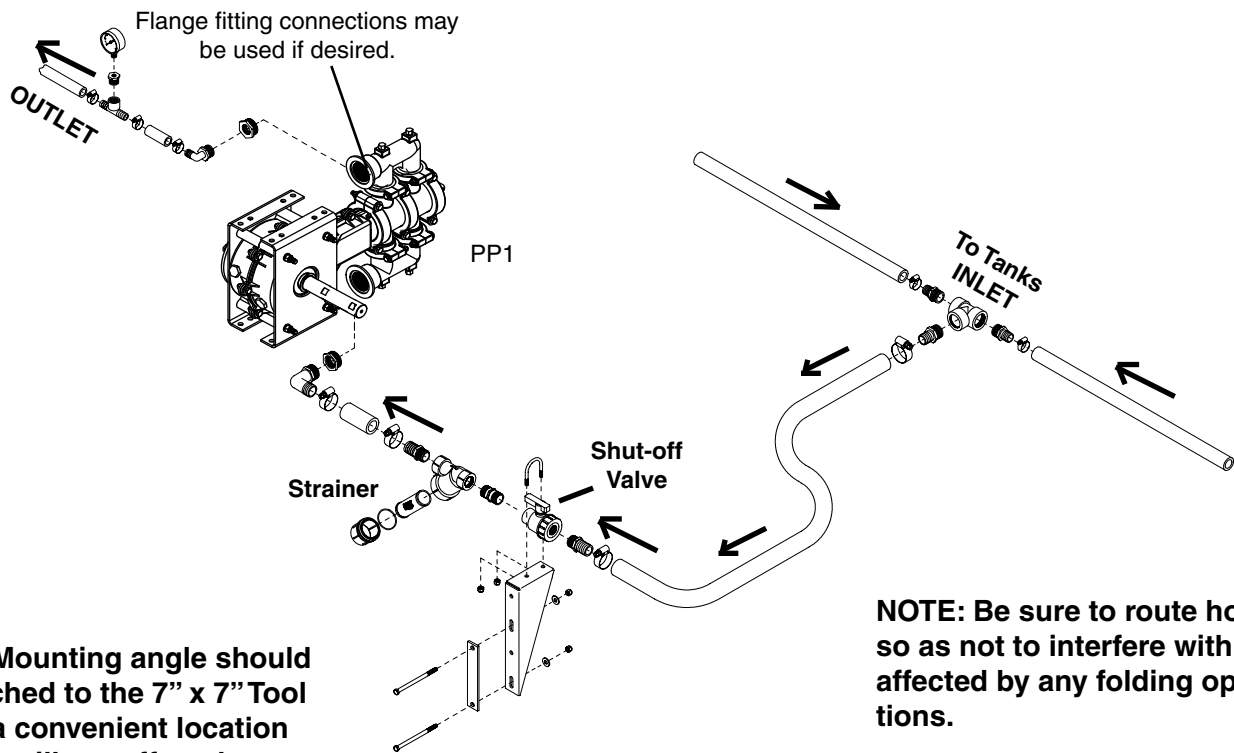

**Caution: To prevent personal injury, observe the following precaution.**

**DO NOT install a shut-off valve in the discharge line as it may be left shut and cause extensive damage to the pump and hoses.**

### SUCTION AND DISCHARGE LINES

The suction and discharge lines must be large enough for the flow required. For high volume the hose to the inlet manifolds must be no less than 1-1/2" diameter reinforced hose on the PP1 and 2" diameter reinforced hose on the PP2. The suction line should be as short as possible and free from any bends that might cause an air trap. In-line filters or strainers must be cleaned frequently and they must be large enough not to restrict flow as this may affect output accuracy.

**Do not plumb filters, strainers or manifolds directly to the pump manifolds as the extra weight puts undue stress on the pump manifolds. These items should be mounted to the implement frame and plumbed to the pump using a suitable length of hose. It is also strongly recommended to have a pressure gauge plumbed into the discharge line.**

Spray pressure can be approximated by selecting the proper size tips for the speed traveled and volume required (refer to the slide chart provided with your pump). **PRESSURE MUST NOT EXCEED 100 PSI. PUMP SPEED MUST NOT EXCEED 210 RPM. OPTIMUM OPERATING PRESSURE IS 20-40 PSI.**

Use of a check valve in each discharge is recommended.



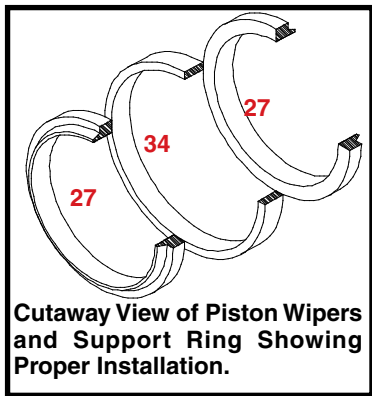
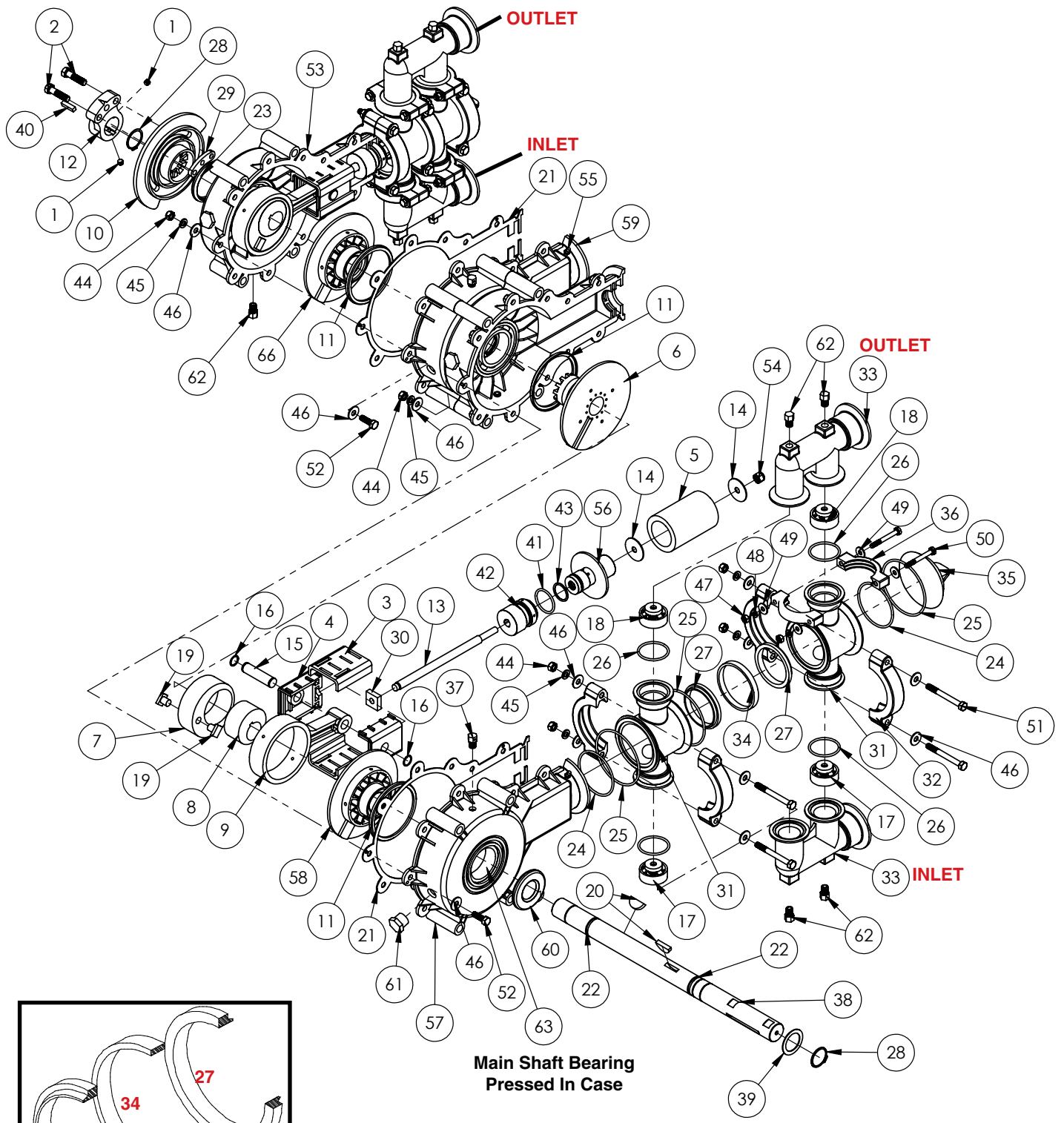

Main Shaft Bearing Pressed In Case

## PISTON PUMP PARTS LIST

REF. NO.	PART NO.	QTY.		DESCRIPTION
		PP1	PP2	
1.	00087	2	2	5/16"-18UNC x 5/16" Socket Set Screw
2.	00914	2	2	3/8"-16UNC x 1-1/2" Hex Bolt
3.	01166	2	4	Pump Connecting Slide Cover
4.	01167	2	4	Pump Connecting Slide
5.	01168	1	2	UHMW Piston
6.	01169	1	2	Drive Hub, adjustment side
7.	01171	1	2	Large Eccentric
8.	01172	1	2	Small Eccentric
9.	01173	1	2	Connecting Rod
10.	01176	1	1	Adjustment Disc
11.	01177	2	4	Drive Hub Thrust Bearing
12.	01191-95	1	1	Adjustment Pointer
13.	01265	1	2	Piston Rod
14.	01313	2	4	SS Piston Thrust Washer
15.	01317	1	2	Wrist Pin
16.	01318	2	4	Wrist Pin Snap Ring
17.	01320	2	4	Intake Manifold Check Valve (Blue)
18.	01321	2	4	Exhaust Manifold Check Valve (Red)
19.	01390	2	4	Drive Hub Adjusting Pin
20.	01391	1	2	1/4" x 1-1/8" Woodruff Key
21.	01426	1	2	Drive Case Gasket
22.	01516	2	2	Main Shaft O-Ring
23.	01517	1	1	Drive Hub Oil Seal (Adjustment Side)
24.	01520	2	4	Cylinder Housing Small O-Ring
25.	01521	3	6	Cylinder Housing Large O-Ring
26.	01522	4	8	Check Valve O-Ring
27.	01524	2	4	Piston Wiper
28.	01528	2	2	Main Shaft Snap Ring
29.	01529-95	1	1	Adjustment Pointer Locking Plate
30.	01530	1	2	Piston Rod Retaining Block
31.	01534	2	4	Cylinder Housing
32.	01535	6	12	Large Clamp
33.	01536	2	4	Intake/Exhaust Manifold
34.	01537	1	2	Piston Wiper Support Ring
35.	01538	1	2	End Cap
36.	01539	8	16	Small Clamp
37.	01597	1	2	1/4" NPT Nylon Breather Plug
38.	01596	1	-	1-1/4" O.D. Main Shaft for PP1

REF. NO.	PART NO.	QTY.		DESCRIPTION
		PP1	PP2	
38.	01599	-	1	1-1/4" O.D. Main Shaft for PP2
39.	01979	2	1	1-1/4" I.D. 18 Ga. Machine Bushing
40.	01989	1	1	1/4" x 1/4" x 1" Key
41.	12489	1	2	Piston Rod Guide Bushing O-Ring
42.	01992	1	2	Piston Rod Guide Bushing
43.	01993	1	2	Rear Stackpack Retainer O-Ring
44.	01996	17	34	5/16"-18UNC Stainless Steel Hex Nut
45.	01997	17	34	5/16" Stainless Steel Lockwasher
46.	01998	34	68	5/16" Stainless Steel Flatwasher
47.	02000	8	16	1/4"-20UNC Stainless Steel Hex Nut
48.	02001	8	16	1/4" Stainless Steel Lockwasher
49.	02002	16	32	1/4" Stainless Steel Flatwasher
50.	02004	8	16	1/4"-20UNC x 2-1/4" SS Hex Head Bolt
51.	02005	6	12	5/16"-18UNC x 3" SS Hex Head Bolt
52.	02006	11	22	5/16"-18UNC x 1" SS Hex Head Bolt
53.	02200	1	1	Half Drive Case
54.	04632	1	2	3/8"-16UNC Stainless Steel Locknut
55.	04642	1	2	Grease Zerk
56.	5136	1	2	Stackpack Sub-Assembly
57.	11924	1	1	Half drive Case (Clutch side)
58.	11926	1	1	Drive Hub, Clutch Side
59.	11927	-	1	Center Drive Case
60.	11929	1	1	Drive Hub Oil Seal (Clutch side)
61.	F1200	2	4	1/2" NPT Nylon Plug
62.	F1400	5	10	1/4" NPT Nylon Plug
63.	02501	2	2	Main Shaft Bearing (pressed in case)
64.	01582	1	1	Pump Rate Chart
65.	11521-95	1	1	Pump Adjusting Tool
-	11474-30	-	1	Tool Storage Bracket
66.	01174	-	1	Connector Drive Hub
<b>5224</b>		<b>1</b>	<b>2</b>	<b>Seal Replacement Kit</b>
24.	01520	2	4	Cylinder Housing Small O-Ring
25.	01521	3	6	Cylinder Housing Large O-Ring
26.	01522	4	8	Check Valve O-Ring
27.	01524	2	4	Piston Wiper
43.	01993	1	2	Rear Stackpack Retainer O-Ring

Please order replacement parts by PART NO. and DESCRIPTION.

**NOTE:** The Intake Manifold Check Valves (blue) have weaker springs than the Exhaust Manifold Check Valves (red).

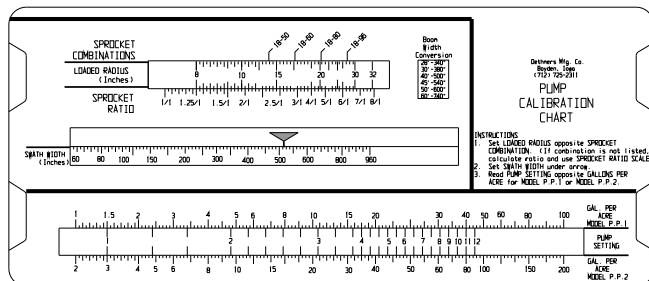

64

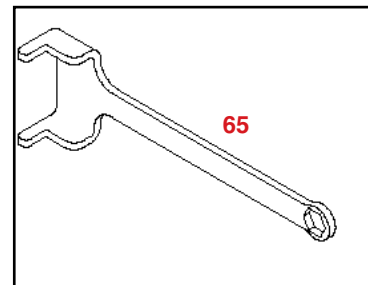

65



# MANUAL CLUTCH PARTS BREAKDOWN

**NOTE: Clutch Throw out Yoke must be positioned as shown, with block "A" facing the pump.**

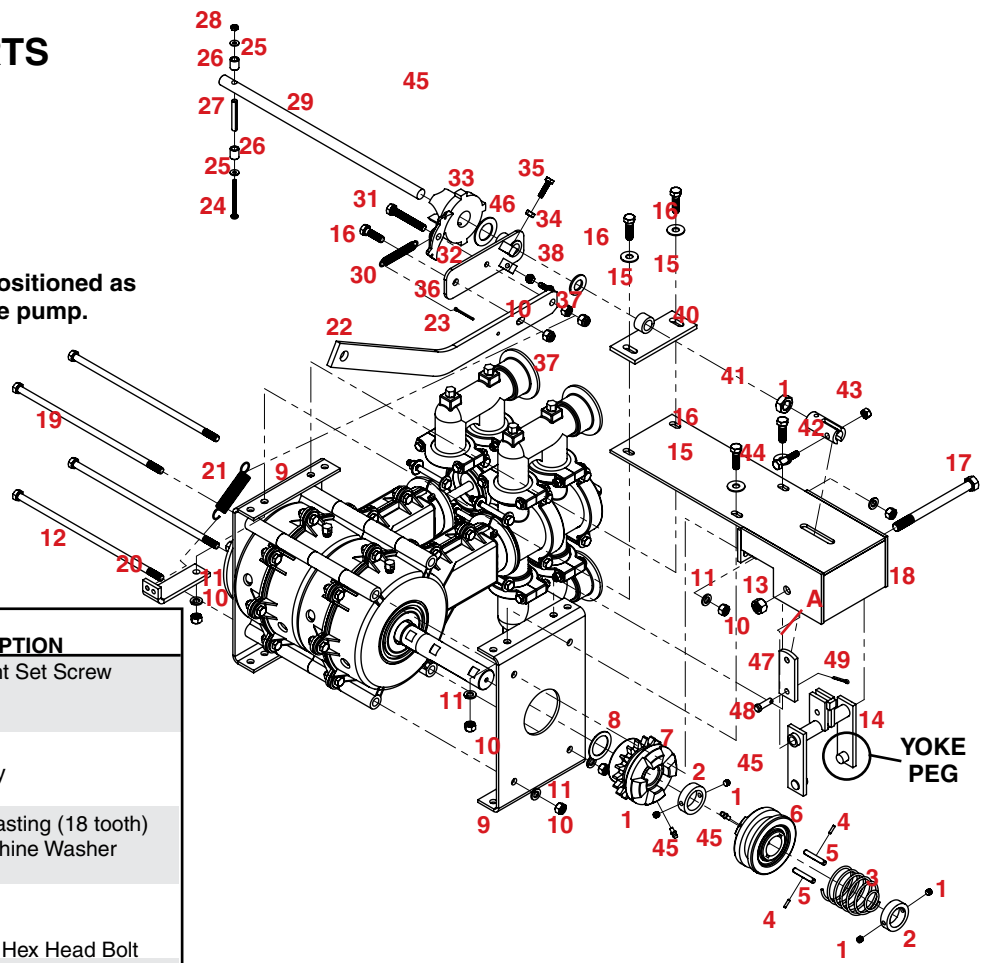

REF. NO.	PART NO.	QTY.		DESCRIPTION
		PP1	PP2	
1.	00087	5	5	5/16" x 5/16" Cup Point Set Screw
2.	01598-95	2	2	1-1/4" I.D. Lock Collar
3.	01193	1	1	Clutch Spring
4.	01976	2	2	1/8" x 1/2" Roll Pin
5.	01549	2	2	1/4" x 1/4" x 1-5/8" Key
6.	01184 1 1/4-30	1	1	1-1/4" I.D. Clutch Yoke
7.	01183 1 1/4-30	1	1	1-1/4" I.D. Sprocket Casting (18 tooth)
8.	01979	1	1	1-1/4" I.D. 18 Ga. Machine Washer
9.	01498-30	2	2	Pump Side Plate
10.	00061	9	9	3/8"-16UNC Hex Nut
11.	00060	8	8	3/8" Lockwasher
12.	02056	-	2	3/8"-16UNC x 11-1/2" Hex Head Bolt
12.	00613	2	-	3/8"-16UNC x 6" Hex Head Bolt Gr. 5
13.	00173	1	1	1/2"-13UNC Locknut
14.	01576-30	1	1	Clutch Throw Out Yoke
15.	00059	4	4	3/8" Flatwasher
16.	00523	5	5	3/8"-16UNC x 1.25" Hex Head Bolt Gr. 5
17.	00349	1	1	1/2"-13UNC x 6" Hex Head Bolt Gr. 5
18.	01525-30	1	-	Piston Pump Top Bracket
18.	01526-30	-	1	Piston Pump Top Bracket
19.	02057	-	2	3/8"-16UNC x 12" Hex Head Bolt
19.	04219	2	-	3/8"-16UNC x 6-1/2" Hex Head Bolt Gr. 5
20.	01527-30	1	1	Throw Out Arm Return Spring Bracket
21.	01547	1	1	Throw Out Arm Return Spring
22.	01211-30	1	1	Throw Out Arm Extension Handle
23.	01982	1	1	3/32" x 1-1/4" Cotter Key
24.	01983	1	1	#10 x 2-1/2" Round Head Stove Bolt
25.	07490	2	2	3/16" Flatwasher
26.	01212-95	2	2	Throw Out Roller
27.	01985	1	1	5/16" x 2" Roll Pin
28.	01986	1	1	#10 Nut
29.	01214-95	1	-	Throw Out Shaft
29.	01565-95	-	1	Throw Out Shaft
30.	01548	1	1	Throw Out Pawl Spring
31.	01987	1	1	3/8"-16UNC x 2-1/2" Full Thread Hex Head Bolt
32.	01185	1	1	Throw Out Pawl
33.	01186-30	1	1	Throw Out Pawl Ratchet Casting
34.	00062	2	2	1/4"-20UNC Hex Nut
35.	04055	2	2	1/4"-20UNC x 1" Hex Head bolt
36.	01213-30	1	1	Throw Out Arm Plate
37.	02592	2	2	3/8"-16UNC Nylon Insert Locknut
38.	00496	1	1	5/8" Machine Washer
39.	00914	1	1	3/8"-16UNC x 1-1/2" Hex Head Bolt Gr.5
40.	01216-30	1	1	Throw Out Arm Bracket
41.	00489	1	1	5/8"-11UNC Jam Nut
42.	01215-95	1	1	Clutch Throw Out Shaft Yoke Connector
43.	02802	1	1	5/16"-18UNC Nylon Insert Locknut
44.	00372	1	1	5/16"-18UNC x 1-1/2" Hex Bolt Gr. 5
45.	05023	4	4	3/16" Grease Zerk
46.	05587	1	1	1.00" X 14GA Machine Washer
47.	01575-30	1	1	Top Pivot Yoke Link
48.	02528	1	1	Clevis Pin
49.	00009	1	1	1/8" Cotter Pin

## ADJUSTMENT INSTRUCTIONS

Bolt the throw out arm bracket (#40) and arm assembly (pre-assembled at factory) to the top of the pump using two 3/8" bolts. The 1-1/2" long bolt should be used to attach the return spring bracket (#20). Connect the return spring (#21) and remove any remaining shipping tape from the assembly. Loosen set screw (#1) in clutch throw out shaft connector (#42). Turn connector, **not the shaft**, until holes align for the 5/16" x 1-1/2" bolt (#44) to pass through connector and Yoke (#14). Lock connector in place by tightening jam nut (#41). Grease the zerk in the throw out ratchet casting (#33) before using the pump and as needed thereafter. An occasional drop of oil to the other moving parts of the clutch will prevent unnecessary wear. Check to make sure the clutch completely disengages. The sprocket casting should turn freely. The handle should return to engage the next cog in the throw out ratchet casting when the clutch is tripped.

**Important:** Make sure the clutch throw out yoke pegs fit loosely in the groove in the clutch yoke casting when the clutch is engaged.

Attach the pull rope to the eye in the throw out handle to permit operation of clutch from the tractor cab. To change the direction of pull for the clutch handle, simply remove the handle and install it in the opposite position. Then re-hook the throw out pawl spring in the other hole in the throw out pawl and move the spring return bracket to the other side of the handle assembly and re-hook the return spring. Make sure the pawl works freely on the side of the throw out arm plate.

## PISTON WIPER REPLACEMENT

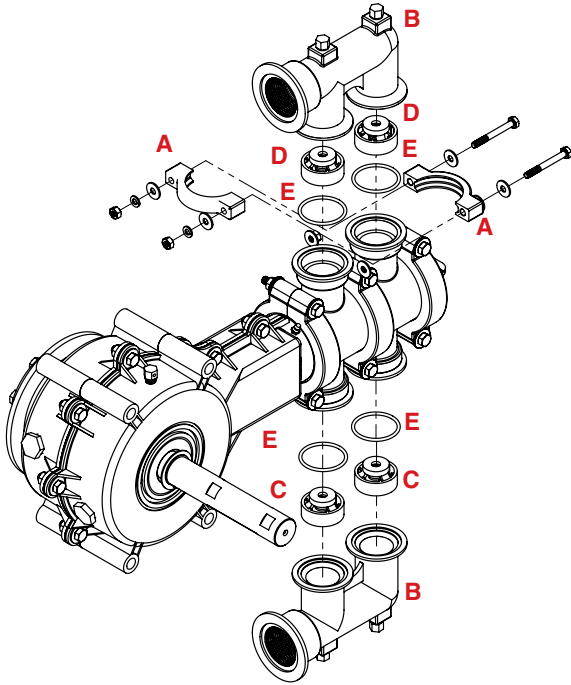

1. Remove small manifold clamps (A), top and bottom, then remove the inlet and outlet manifolds (B). This exposes the valves, inlet valves on bottom (blue) (C), and outlet valves on top (red) (D). Remove valve o-rings (E) making sure valves are clear of matter and in proper working condition.

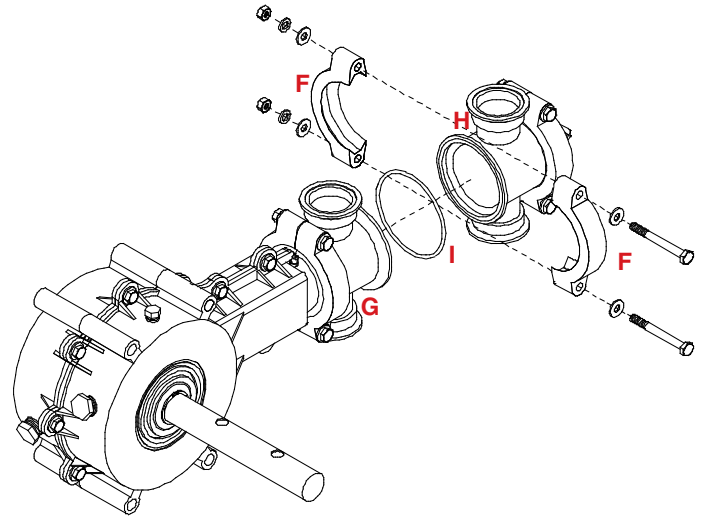

2. Remove center large cylinder housing clamp (F). Separate cylinder housings (G&H) and remove front housing (H) and o-ring (I).

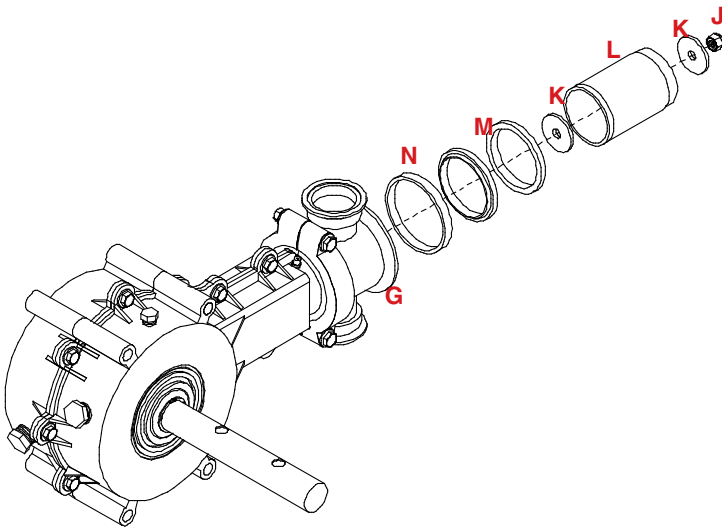

3. Remove stainless steel piston nut (J), and thrust washer (K). Pull out the piston (L), and wipers (M) to examine. Locate the piston wiper support ring (N) lodged in one of the cylinder housings (G&H). If deep scratches or grooves are worn into the surface of the wipers or piston they should be replaced at this time.

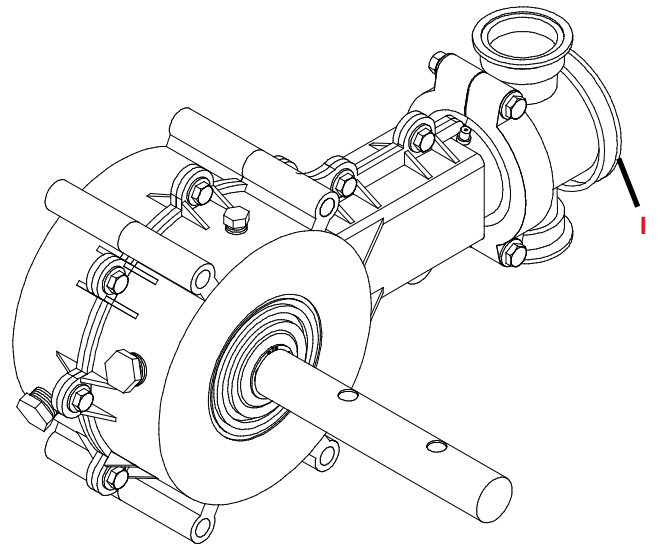

4. **To reassemble:** Place large o-ring (I) over the flare on the cylinder housing already assembled to the drive case. Silicone can be used around the sealing areas for extra sealing.

## PISTON WIPER REPLACEMENT

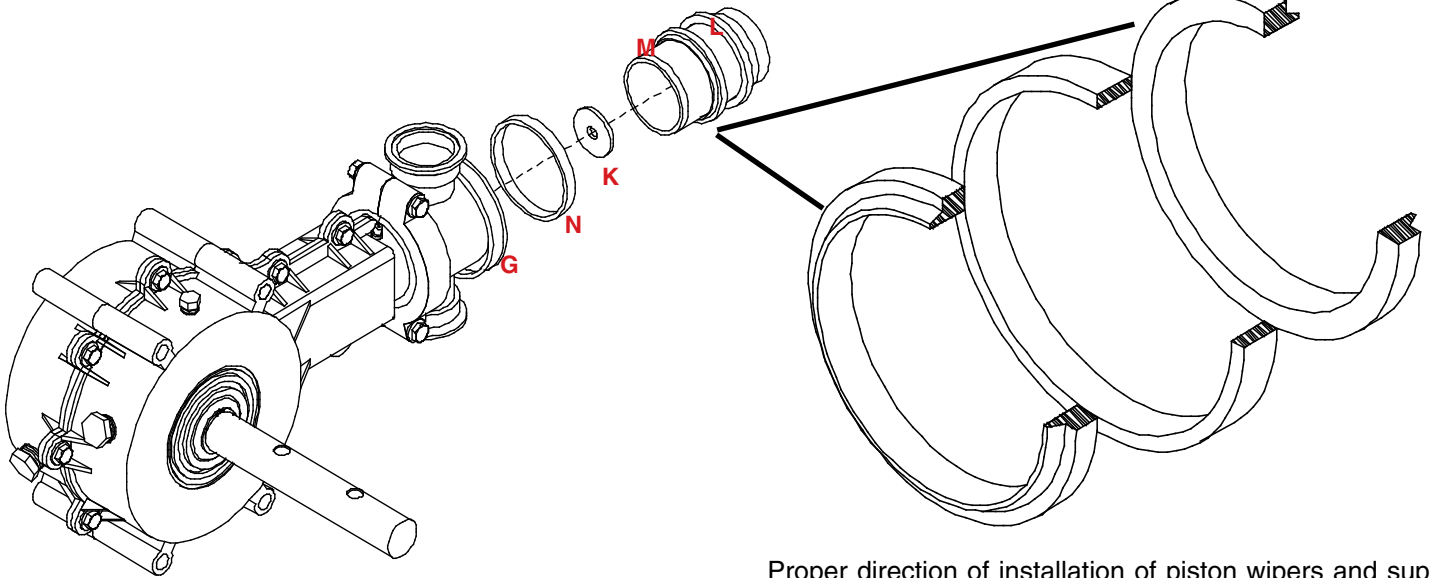

Proper direction of installation of piston wipers and support ring over piston.

5. Insert the wiper support ring (N) into cylinder housing assembled to the drive case (G). Place wipers (M) on the piston (L) one from each end, with the flat side inward. Place inner thrust washer (K) on piston rod and insert the piston (L) and wipers (M).

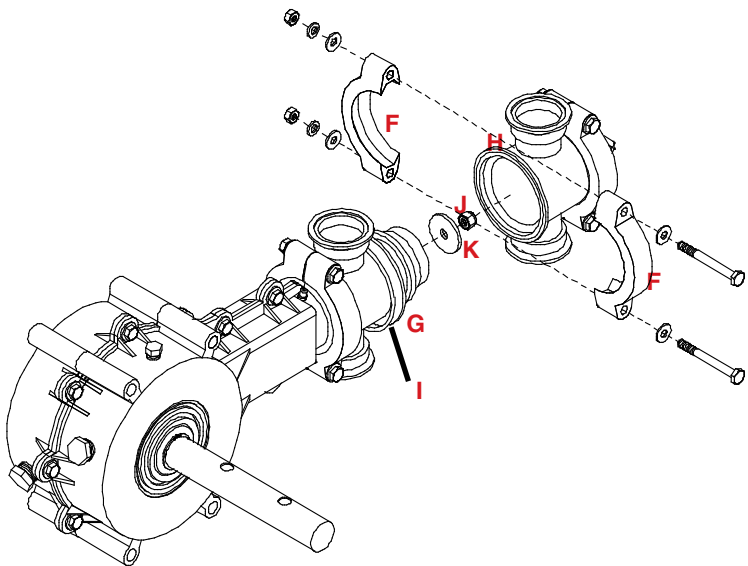

6. Insert the thrust washer (K) and 3/8" stainless steel nylon insert locknut (J) and tighten piston. Place the two cylinder housings (G&H) together and roll the large o-ring (I) over the flare and into the groove. Secure with large cylinder clamp (F) and bolts. **Do Not Tighten Clamps.**

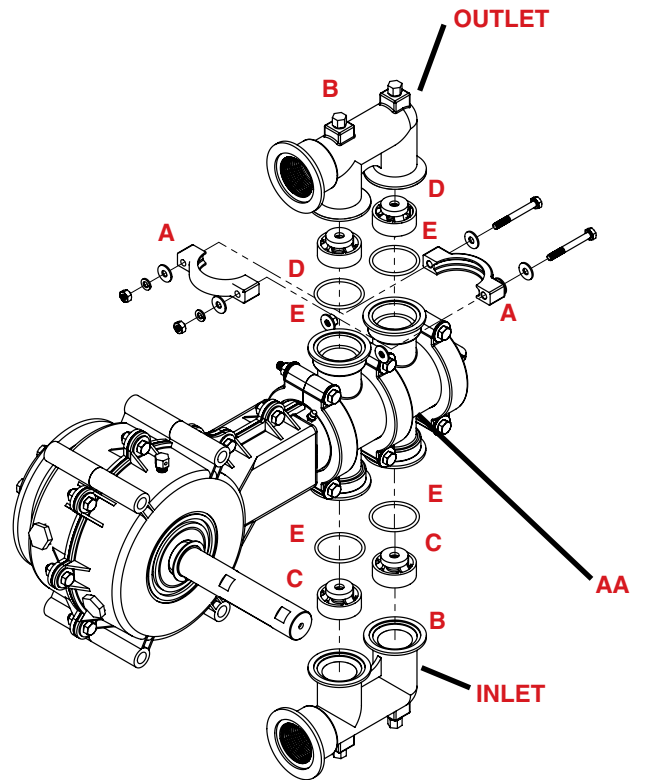

7. Replace the red valves (D) and o-rings (E) on the top side, in an upward direction, and replace outlet manifold (B), clamps (A) and bolts. **Do Not Tighten Clamps.**
8. Replace the blue valves (C) and o-rings (E) on bottom side, in an upward direction, and replace inlet manifold (B), clamps (A) and bolts. **Do Not Tighten Clamps.**
9. Tighten large center clamp (AA) first to draw cylinder housings together, then tighten all remaining large and small clamps.

## STACKPACK REPLACEMENT

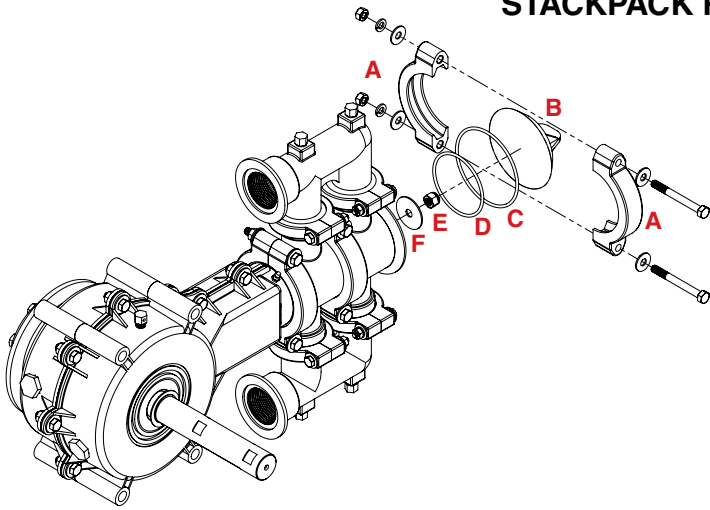

1. Remove large cylinder clamp (A), end cap (B), large o-ring (C) and small o-ring (D). After this has been done remove stainless steel piston nut (E) and thrust washer (F).

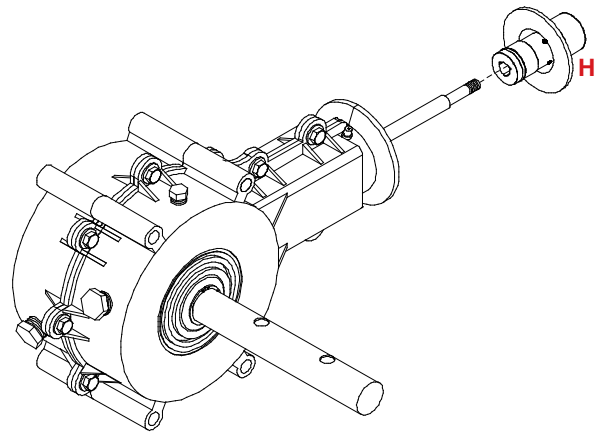

3. Pull and twist off stackpack retainer assembly (H).

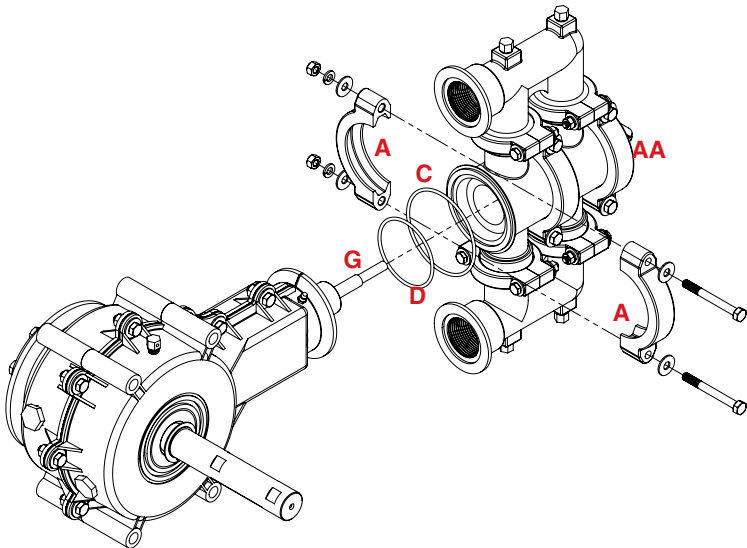

2. Remove large clamp (A). Proceed by pulling the Piston, Large O-ring (C), Small O-ring (D), and the cylinder housing assembly (AA) off of the piston rod (G) **at the same time**. If this is not done simultaneously the cylinder housing assembly will have to be disassembled to properly install wipers & support ring over the piston. Refer to the **Piston Wiper Replacement** section on pages 12 & 13.

4. Oil stackpack and O-ring. Insert stackpack retainer assembly into pump by sliding it over the piston rod.
5. Place large o-ring over the flare on drive case, then slightly stretch small o-ring. This will help hold it in the lip of the rear cylinder housing. Place the first thrust washer on piston rod, then slide the cylinder housings into position with the piston still lodged in the piston wipers. Roll the large o-ring over the flare and into the groove. Secure with large cylinder clamp (A). Insert and tighten the thrust washer and 3/8" stainless steel nylon insert locknut.
6. Place large o-ring over the flare on the front cylinder housing then slightly stretch small o-ring. This will help hold it in the lip of the cylinder housing. Replace end cap and roll the large o-ring over the flare and into the groove. Secure with large cylinder clamp (A).

## DETERMINING SPROCKET RATIOS FOR PISTON PUMPS

It may be difficult in some cases to determine the ratio of the drive for the pump system. The main determining factor is always the size of the driven sprocket in relation to the drive sprocket. Always divide the drive (powered) sprocket size by the driven sprocket (see examples below).

1. Determine the size (no. of teeth) of the Drive Wheel Sprocket and the Driven Sprocket.
2. Divide the number of teeth of the Drive Sprocket by the number of teeth of the Driven Sprocket to determine the Sprocket Ratio.

**EXAMPLE:** 50 tooth drive sprocket divided by 18 tooth driven sprocket = 2.77 sprocket ratio.

### For Jack Shaft Driven Pumps

1. Multiply the number of teeth on all Drive Sprockets together.
2. Multiply the number of teeth on all Driven Sprockets together.
3. Divide Drive Sprocket total by Driven Sprocket total which equals the Sprocket Ratio.

**EXAMPLE:** (see Diagram)

(A) Drive Sprockets 50 x 28=1400

(B) Driven Sprockets 24 x 18=432

(C) 1440/432=3.24

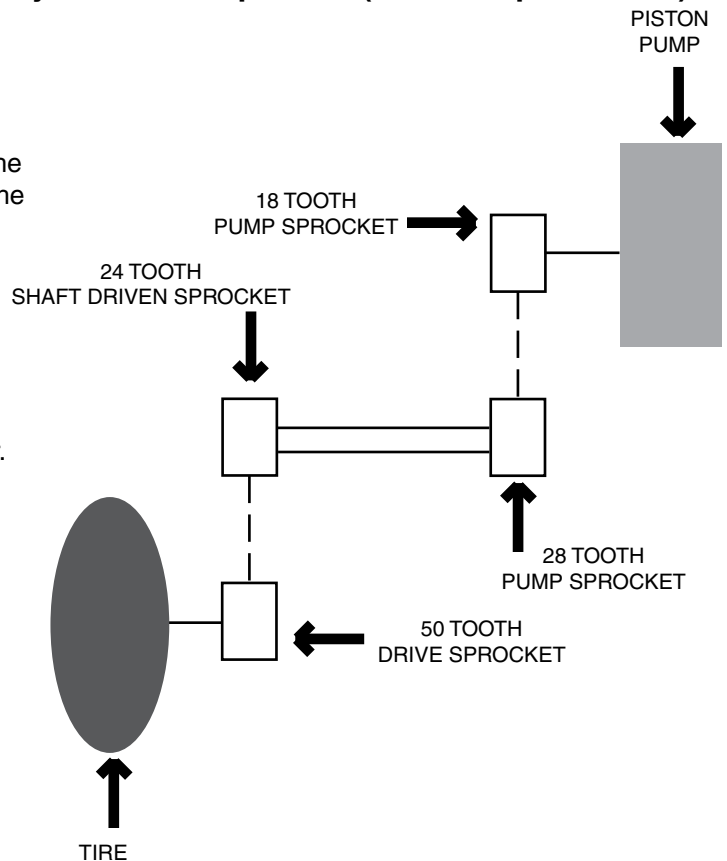

**NOTE:** On units with press wheels, the radius of the drive wheel can be considered as the number of teeth of the large sprocket and the radius of the press wheel can be considered as the number of teeth on the driven sprocket. EXAMPLE: If a planter has a drive wheel with a radius of 17" and the wheel that presses against it has a radius of 6.5", we can simply divide the drive wheel radius (17") by the press wheel radius (6.5"). This gives a ratio of 2.615 to 1. For every revolution of the ground wheel, the press wheel turns 2.615. Generally, in this case, a sprocket is mounted on the press wheel. This sprocket would turn 2.615 revolutions for every 1 of the ground wheel, and the ratios can be figured as described in the first paragraph.

### LOADED RADIUS CHART

TIRE SIZE	LOADED RADIUS
T590L	12.4"
T9.5L	13.6"
T11L	13.5"
T12.5L	15.5"
T13.6	26.5"
T16.9	23.2"
T18.4	25.4"

**Loaded Radius** = Measurement from surface of the ground to the center of the hub.

The above chart is to be used as a guideline only. Figures are based upon a sprayer with 1/2 tank of water. Size of tank, weight of solution, soil condition etc. may alter these numbers. Check your **Loaded Radius** with a tape measure. THIS IS VERY IMPORTANT.



# ROUTINE MAINTENANCE

Your Lil' Thumper is designed to require only occasional light maintenance. Attention to the following procedures will significantly prolong the useful life of your pump.

1. Make a habit of carefully checking all nuts, bolts, fittings, plugs, hoses and hose clamps daily to see that they are secure.
  
2. Check drive chain alignment. If uneven sprocket wear occurs, loosen the pump mounting bracket and move pump and bracket accordingly. Keep the drive chain lubricated with a good quality chain lubricant.
  
3. Keep the external surfaces of the pump clean. Dirt and grease can cling to the pump in a heavy layer and may cause an unnecessary heat build-up which can shorten the life of your pump. A high pressure spray washer is recommended to remove dirt and chemicals from the pump and clutch assemblies after each use. Cover the vent hole in the 1/4" breather plugs (located in the top of the drive cases) so water does not enter the drive cases. Uncover the breather plugs when washing is done.

4. Change the oil in the drive case of your pump annually. This is done by removing the 1/2" fill plugs and the 1/4" drain plugs and draining the oil. When all the oil has drained out, replace the 1/4" drain plugs and fill the drive cases to the bottom of the check plug hole with a good quality non-detergent 30 weight oil as described in the "LUBRICATION" section of this manual.

5. If chemical or water is found in the oil, the stackpack glands may be leaking. Refer to the "PARTS BREAKDOWN" section of this manual to replace these parts or see your dealer for service assistance.

**If replacement parts are required, order by part number and description to insure prompt shipment.**

6. Check the weep hole at the bottom front of the pump neck. Any solution leaking there means that the front stackpack is worn and should be replaced. Keep the airway in the drive case breather plug clean. Remove the plug to clean. This will keep dirt from falling into the drive case.

<b>MAINTENANCE SCHEDULE</b>	<b>6 HRS</b>	<b>DAILY</b>	<b>*AS NEEDED</b>	<b>50 HRS</b>	<b>ANNUALLY</b>
<b>NUTS, BOLTS, CLAMPS, FITTINGS &amp; HOSES</b>		●			
<b>DRIVE CHAIN ALIGNMENT</b>			●		
<b>CLEAN EXTERNAL SURFACES</b>		●			
<b>CHANGE OIL</b>				●	●
<b>GREASE CLUTCH</b>		●			
<b>GREASE STACKPACKS</b>	●				
<b>CHECK OIL LEVEL</b>		●			
<b>REPLACE SEALS, ETC.</b>			●		●
<b>LUBRICATE CHAIN</b>			●		

\* Refer to specific information listed in maintenance, lubrication and other sections of this manual.

## MAINTENANCE RECORD

<u>DATE</u>	<u>TYPE OF MAINTENANCE</u>	<u>DATE</u>	<u>TYPE OF MAINTENANCE</u>



## TROUBLE SHOOTING FOR PISTON PUMP

PROBLEM	PROBABLE CAUSE	SOLUTION
Pump will not prime	Valves fouled	Clean valves
	Piston wipers worn	Replace Wipers
	Strainer plugged	Clean strainer
	Sucking air in suction line	Repair line
	Air lock in suction line	Reroute suction line
	Worn piston	Replace piston
Pump puts out too little	Valves fouled	Clean valves
	Piston wipers worn	Replace wipers
	Strainer plugged	Clean Strainer
	Sucking air in suction line	Repair line
	Air lock in suction line	Reroute suction line
	Worn piston	Replace piston
	Broken valve spring	Replace valve
	Improper rate setting	Check calibration
Pump puts out too much	Improper setting	Check calibration
Chemical leaks through after pump has stopped	Broken valve spring	Replace valve
	Valves fouled	Clean valves
Solution leaking from weep hole at bottom front of pump neck	Stackpack glands worn	Replace stackpacks
	Piston rod could be worn	Replace rod
Pump leaks oil	Oil seal or O-ring worn	Replace seals
	Too much oil in drive case	Lower oil level
	Torn gasket	Replace gasket

## PISTON PUMP STORAGE

**Short term storage - overnight** - in steady or rising temperatures: No special precautions are necessary. **DO NOT DRAIN OR ADMIT AIR!**

**In Falling Temperatures** - Shut off valve between tank and pump. Remove the inlet and outlet hoses and inlet manifold plugs. Using a long thin rod, drain the inlet valve by pumping the rod up and down into each of the inlet manifold plug holes until the chemical mixture in the valve bodies and cylinder runs out (about two cups of fluid). **Note: Catch all draining chemicals and return to tank.** Loosen the pump from the mounting and tip on end to completely drain the outlet manifolds. Remount the pump. Replace and tighten the manifold plugs and check oil level in pump.

**Seasonal storage** - Disassemble pump and clean all internal parts individually. Replace any worn parts such as piston, piston wipers, stackpacks, piston rod, etc. After washing all internal parts with soap and water, coat all parts with motor oil. Reassemble and fill pump with RV antifreeze. Make sure the valves are installed correctly with the BLUE valves in the inlet manifold and the RED valves in the outlet manifold. Refer to the PARTS BREAKDOWN section of this manual for proper valve placement. Close and seal all openings.

**NOTE:** The main factors in the pump affecting output are the piston, wipers and the valves. It may be advisable to keep a spare set of wipers on hand and make sure your dealer has pistons and valves on hand or readily available. This is to prevent delays during the season in case the pump is run dry and premature wear is experienced.

# EQUIPMENT CHECKLIST:

Downtime caused by field breakdowns is costly and time consuming. Many breakdowns can be eliminated by periodic equipment maintenance. By spending time reviewing this checklist before seasonal spraying application time and following proper after-season care, you can save time and money later.



## **WARNING:** To Prevent Serious Injury Or Death

- Keep hands, feet, and loose clothing away from rotating parts.
- Wear protective clothing recommended by your chemical and fertilizer manufacturer when working with chemicals.

### Check Before Going To The Field :

#### 1. NOZZLES

Check tip for excessive wear by checking for grooves in or near tip opening. Check nozzle spacing by starting at center and working outwards. Check boom for proper height.

#### 2. HOSES

Check all hoses for worn or soft spots. Be sure all hose clamps are tightened and hoses are not kinked or pinched. Check for leakage in any lines.

#### 3. TANK

Remove and clean agitator orifices. Check orifices for excessive wear by checking for grooves in or near orifice opening. Inspect fitting and grommets to insure they are in good condition.

#### 4. CONTROLS

Check for leakage, plugging, or wear on all valves, fittings, etc. Clean off any build up of foreign material.

#### 5. PUMP

Check to be sure pump turns freely.

#### 6. FRAME

Be sure all bolts are tightened.

#### 7. REPLACEMENT PARTS

Replace all worn or damaged parts.

### After Season Care:

**NOTE:** It is important to wear proper safety equipment when cleaning the sprayer. See your chemical or fertilizer package for this information.

1. After spraying chemicals, run water mixed with cleaners through tank, pump and all hose hookups. If wettable powder dries out in the system, it is very difficult to put back into suspension and can cause malfunction, damage or injury.
2. When cleaned, tank should have all openings closed or covered to keep dirt from entering.
3. Pump should be flushed with soluble oil and pump ports plugged to keep out moisture and air.
4. Disassemble tips and rinse with water or cleaning solution. (Appropriate for chemical sprayed).
5. Clean tip opening with a wooden toothpick. Never use wire or hard object that could distort opening.
6. Dispose of all unused chemicals or solutions in a proper and ecologically sound manner.
6. Water rinse and dry tips before storing.

---

**NOTE:** DEMCO does not and will not make any recommendations concerning application of various chemicals or solutions. These recommendations relate to either amount or procedure of materials applied. If you have any questions regarding application of certain chemicals or solutions, contact your chemical supplier and follow chemical manufacturer recommendations.

# DEMCO

4010 320th St., Boyden, IA. 51234

Phone: (712) 725-2311

Fax: (712) 725-2380

Toll Free: 1-800-54DEMCO (1-800-543-3626)

**Demco warranty policies, operator manuals, and product registration  
can be found online:**

**[www.demco-products.com](http://www.demco-products.com)**

