

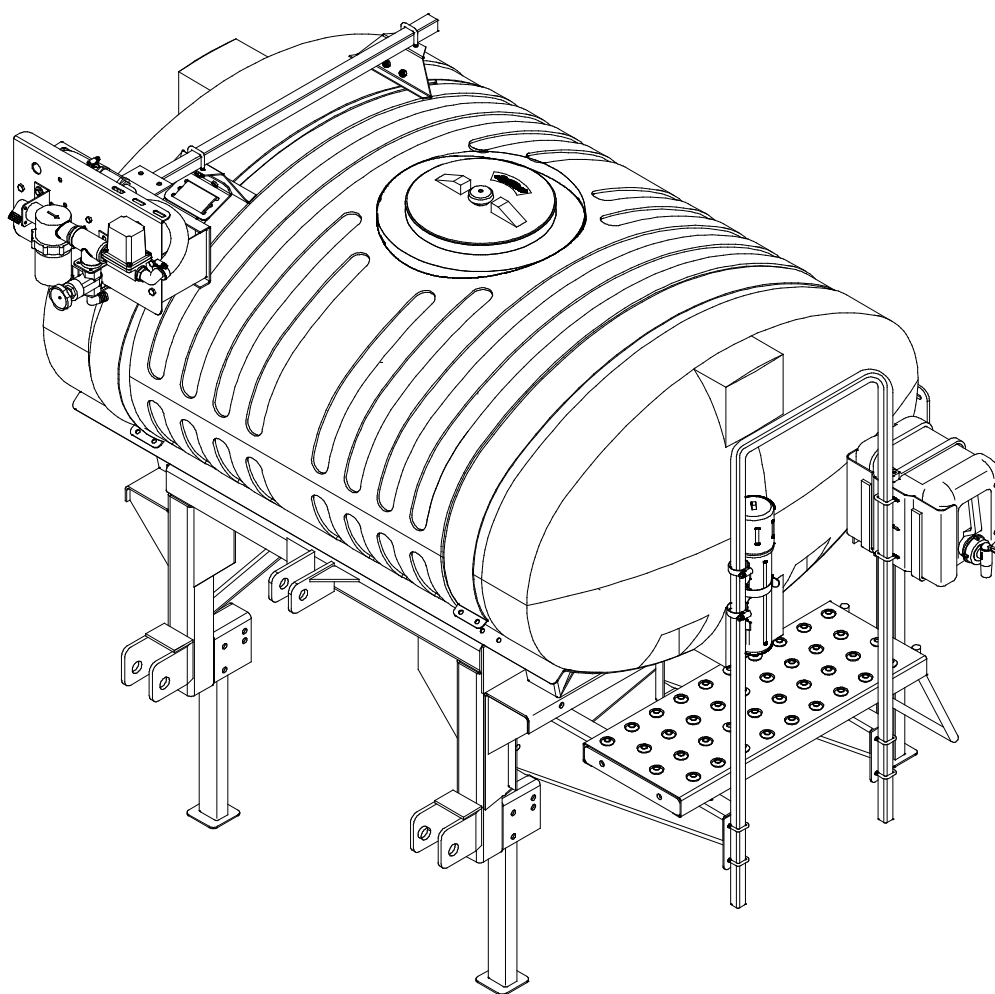

Demco

RMLE

Rear Mounted Sprayer



ASSEMBLY
CALIBRATION
OPERATION
REPLACEMENT PARTS

READ *complete manual CAREFULLY*
BEFORE attempting operation.

Doing Our Best to Provide You the Best

OPERATORS MANUAL

Thank you for purchasing a Demco sprayer. We feel you have made a wise choice and hope you are completely satisfied with your new sprayer. If you have any questions regarding the applications of certain solutions or chemicals, contact your chemical supplier and follow chemical manufacturer recommendations as well as all licensing and use restrictions or regulations.



WARNING: TO AVOID PERSONAL INJURY OR PROPERTY DAMAGE, OBSERVE FOLLOWING INSTRUCTIONS:

Chemicals are dangerous. Know exactly what you're going to do and what is going to happen before attempting to work with these products. Improper selection or use can injure people, animals, plants and soil.

Always wear protective clothing such as coveralls, goggles and gloves when working with chemicals or sprayer.

Be sure to dispose of all unused chemicals or solutions in a proper and ecologically sound manner.

GENERAL INFORMATION

1. Unless otherwise specified, high-strength (grade 5) (3 radial-line head markings) hex head bolts are used throughout assembly of this sprayer. proper part numbers and place order by **PART NO., DESCRIPTION, and COLOR.**
2. Whenever terms “**LEFT**” and “**RIGHT**” are used in this manual it means from a position behind sprayer and facing forward.
3. When placing a parts order, refer to this manual for

Table of Contents

General information	2
Warranty Registration	3-4
Safety Information	5-11
Bolt Torque.....	12
Tank And Tank Skid Mounting	13
Legs, Platform, Step, Mounting	14
Handrail, Manual Canister, Fresh Water Tank, and Boom Carrier Mounting Parts Breakdown	14
Foam Marker (DFM60) Mounting Bracket Parts Breakdown and List	15
RMLE Rear Mount Tank Bracket Parts Breakdown and Assembly.....	16-17
Panel Mount (Strap Method) Parts Breakdown and Installation Instructions.....	18
Polyester Bands for Demco Tanks	19
DB and DFBII Boom Mounting Brackets(9416004) Parts Breakdown and List	20
Ground Storage Stands for X-Fold Parts Breakdown and Assembly Instructions	21
Category II and Category III Parts Breakdown and List	22
Single Section Plumbing Kit (9470004) Parts Breakdown and List.....	22
3 Section Plumbing Kit (9470005) Parts Breakdown and List	23
Sprayer Checklist.....	24



Warranty Registration

4010 320th Street • Box 189 • Boyden, Iowa 51234
Toll Free 800-54DEMCO (800-543-3626) • FAX 800-845-6420
www.demco-products.com

Ag	<input type="radio"/>
RV	<input type="radio"/>
Rental	<input type="radio"/>
Brakes	<input type="radio"/>
Marine	<input type="radio"/>

	Very Satisfied	Satisfied	Dissatisfied	Very Dissatisfied
How satisfied are you with our product?	<input type="radio"/>	<input type="radio"/>	<input type="radio"/>	<input type="radio"/>
How satisfied are you with the dealership/distributor sales staff? Dealer/Distributor Name _____ City _____ State _____	<input type="radio"/>	<input type="radio"/>	<input type="radio"/>	<input type="radio"/>
How satisfied are you with the company sales staff?	<input type="radio"/>	<input type="radio"/>	<input type="radio"/>	<input type="radio"/>
How satisfied are you with the delivery?	<input type="radio"/>	<input type="radio"/>	<input type="radio"/>	<input type="radio"/>
Did you have any contact with a Demco Representative? If YES , how satisfied were you?	YES <input type="radio"/>	NO <input type="radio"/>	<input type="radio"/>	<input type="radio"/>
I would recommend this product to my family and friends.	YES	NO		
Would you purchase again from DEMCO?	YES	NO		
Since taking delivery, have you been contacted by the dealer?	YES	NO		
Did you have any problems with this DEMCO product? If YES , are you satisfied with the company's resolution of your problem?	YES <input type="radio"/>	NO <input type="radio"/>	<input type="radio"/>	<input type="radio"/>

Please list the specific source of information prompting this purchase.

After purchasing this product, do you see any needed product improvement? _____ If yes, what improvement? _____

What other products would you like to see DEMCO offer? _____

Comments _____

Owner's Name: _____ Mailing Address: _____

City: _____ State: _____ Zip Code: _____

Model#: _____

Serial #: _____

Purchase Date: _____

Owner's Signature: _____

Please return to DEMCO By FAX or tri-folding this form to the backside, it is pre-addressed.

Postage

*Demco
4010 320th Street, Box 189
Boyden, Iowa 51234*

SAFETY

TAKE NOTE! THIS SAFETY ALERT SYMBOL FOUND THROUGHOUT THIS MANUAL IS USED TO CALL YOUR ATTENTION TO INSTRUCTIONS INVOLVING YOUR PERSONAL SAFETY AND SAFETY OF OTHERS. FAILURE TO FOLLOW THESE INSTRUCTIONS CAN RESULT IN INJURY OR DEATH.



THIS SYMBOL MEANS

ATTENTION

BECOME ALERT

YOUR SAFETY IS INVOLVED!

SIGNAL WORDS

Note use of the following signal words **DANGER**, **WARNING**, and **CAUTION** with safety messages. Appropriate signal word for each has been selected using the following guidelines:

DANGER:

Indicates an imminently hazardous situation that, if not avoided, will result in serious injury or death. This signal word is to be limited to the most extreme situations typically for machine components which, for functional purposes, cannot be guarded.

WARNING:

Indicates a potentially hazardous situation that, if not avoided, could result in serious injury or death, and includes hazards that are exposed when guards are removed. It may also be used to alert against unsafe practices.

CAUTION:

Indicates a potentially hazardous situation that, if not avoided, may result in minor or moderate injury. It may also be used to alert against unsafe

If you have questions not answered in this manual, require additional copies, or if your manual is damaged, please contact your dealer or Demco, P.O. Box 189, 4010 320th Street, Boyden, IA 51234

ph: (712) 725-2311 Toll Free: 1-800-543-3626 Fax: (712) 725-2380

<http://www.demco-products.com>



SAFETY...YOU CAN LIVE WITH IT



EQUIPMENT SAFETY GUIDELINES

Every year many accidents occur which could have been avoided by a few seconds of thought and a more careful approach to handling equipment. You, the operator, can avoid many accidents by observing the following precautions in this section. To avoid personal injury, study the following precautions and insist those working with you, or you yourself, follow them.

In order to provide a better view, certain illustrations in this manual may show an assembly with a safety shield removed. However, equipment should never be operated in this condition. Keep all shields in place. If shield removal becomes necessary for repairs, replace shield prior to use.

Replace any caution, warning, danger or instruction safety decal that is not readable or is missing. Location of such decals is indicated in this booklet.

Do not attempt to operate this sprayer under the influence of alcohol or drugs.

Review safety instructions with all users.

Operator should be a responsible adult. **DO NOT ALLOW PERSONS TO OPERATE OR ASSEMBLE THIS UNIT UNTIL THEY HAVE DEVELOPED A THOROUGH UNDERSTANDING OF SAFETY PRECAUTIONS AND HOW IT WORKS.**

To prevent injury or death, use a tractor equipped with a roll over protective system (ROPS). Do not paint over, remove, or deface any safety signs or warning decals on your sprayer. Observe all safety signs and practice instructions on them.

Never exceed limits of a piece of machinery. If its ability to do a job, or to do so safely is in question-**DON'T TRY IT.**



LIGHTING AND MARKING

It is the responsibility of customer to know lighting and marking requirements of local highway authorities and to install and maintain sprayer to provide compliance with regulations. Add extra lights when transporting at night or during periods of limited visibility.



SAFETY SIGN LOCATIONS

Types of safety sign and locations on equipment are shown in illustration below. Good safety requires that you familiarize yourself with various safety signs, type of warning, and area or particular function related to that area, that requires your SAFETY AWARENESS.

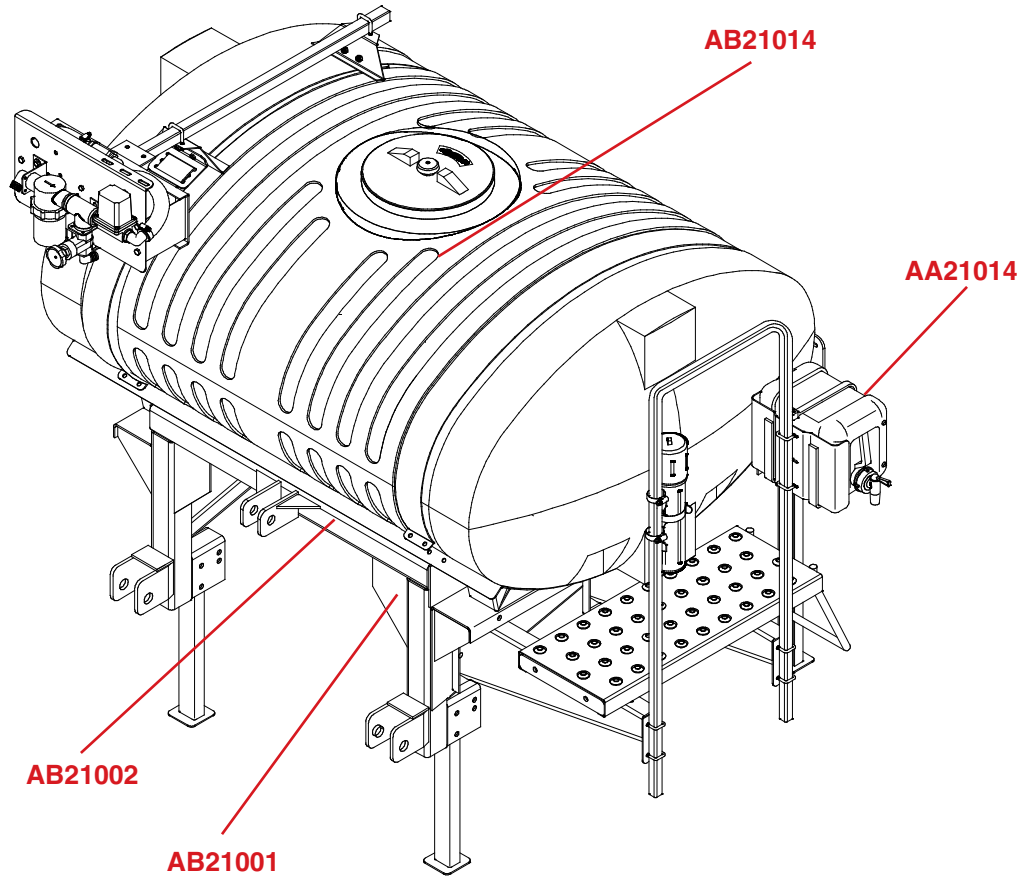

AB21002



AA21014



AB21001

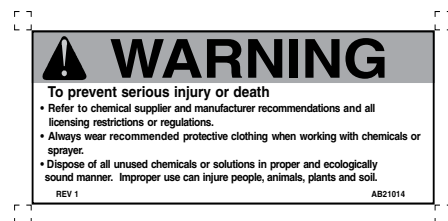

AB21014



SAFETY SIGN CARE

- Keep safety signs clean and legible at all times.
- Replace safety signs that are missing or have become illegible.
- Replacement parts that displayed a safety sign should also display current sign.
- Safety signs are available from your distributor, dealer parts department, or factory.

How to install safety signs:

- Be sure that installation area is clean and dry.
- Decide on exact position before you remove backing paper.
- Remove smallest portion of split backing paper.
- Align decal over specified area and carefully press small portion with exposed sticky backing in place.
- Slowly peel back remaining paper and carefully smooth decal into place.
- Air pockets can be pierced with a pin and smoothed out using piece of backing paper.



BEFORE OPERATION:

- Carefully study and understand this manual.
- Do not wear loose-fitting clothing which may catch in moving parts.
- Always wear protective clothing and substantial shoes.
- It is recommended that suitable protective hearing and eye protection be worn.
- The operator may come in contact with certain materials which may require specific safety equipment relative to handling of such materials. (Examples: extremely dusty, molds, fungus, bulk fertilizers, etc.)
- Give sprayer a visual inspection for any loose bolts, worn parts, or cracked welds, and make necessary repairs. Follow maintenance safety instructions included in this manual.
- Be sure there are no tools lying on or in equipment
- Do not use sprayer until you are sure that area is clear, especially around children and animals.
- Don't hurry learning process or take sprayer for granted. Ease into it and become familiar with your new equipment.
- Practice operation of your equipment and its attachments. Completely familiarize yourself and other operators with its operation before using.
- Use a tractor equipped with Roll Over Protection System (ROPS) and fasten your seat belt prior to starting engine.
- Manufacturer does not recommend usage of a tractor with ROPS removed.



- Move tractor wheels to widest recommended settings to increase stability.
- Do not allow anyone to stand between tongue or hitch and towing vehicle when backing up to sprayer.

DURING OPERATION

- Beware of bystanders, **PARTICULARLY CHILDREN!** Always look around to make sure that it is safe to start engine of towing vehicle or move sprayer. This is particularly important with higher noise levels and quiet cabs, as you may not hear people shouting.
- **NO PASSENGERS ALLOWED-** Do not carry passengers anywhere on or in the tractor or sprayer.
- Keep hands and clothing clear of moving parts.
- Do not clean, lubricate, or adjust your sprayer while it is moving.
- When halting operation, even periodically, set tractor or towing vehicles brakes, disengage PTO, shut off engine, and **remove ignition key**.
- Be especially observant of operating area and terrain- watch for holes, rocks, or other hidden hazards. Always inspect area prior to operation.
 - DO NOT operate near edge of drop-offs or banks.
 - DO NOT operate on steep slopes as overturn may result.
 - Operate up and down (not across) intermediate slopes. Avoid sudden starts and stops.
- Pick the most level possible route when transporting across fields. Avoid edges of ditches, gullies, and steep hillsides.
- Be extra careful when working on inclines.
- Periodically clear sprayer of brush, twigs, or other materials to prevent buildup of dry combustible materials.
- Maneuver tractor or towing vehicle at safe speeds.
- Avoid overhead wires. Contact with overhead lines could cause serious injury or death.
- Avoid loose gravel, rocks, and holes; they can be dangerous for sprayer operation or movement.
- Allow for unit length when making turns.
- Do not walk or work under raised components or attachments unless securely supported.
- Keep all bystanders, pets, and livestock clear of work area.
- Never stand alongside of unit with engine running or attempt to start engine and/or operate machine while standing alongside of unit.
- Never leave running equipment attachments unattended.
- As a precaution, always recheck hardware on equipment following every 100 hours of operation. Correct all problems. Follow maintenance safety procedures.



FOLLOWING OPERATION

- Following operation, or when unhitching, stop tractor or towing vehicle, set brakes, disengage PTO and all power drives, shut off engine and **remove ignition key**.
- Store unit in an area away from human activity.
- Do not park equipment where it will be exposed to livestock for long periods of time. Damage and livestock injury could result.
- Do not permit children to play on or around stored unit.
- Make sure all parked machines are on a hard, level surface and engage all safety devices.



HIGHWAY AND TRANSPORT OPERATIONS

- **SAFETY CHAINS:** If equipment is going to be transported on a public highway, Always follow state and local regulations regarding safety chains and auxiliary lighting. Be sure to check with local law enforcement agencies for your own particular regulations. If required safety chains should be obtained and installed. Only safety chains (not elastic or nylon/plastic tow straps) should be used to retain connection between towing and towed machines in event of separation of primary attaching system. Use a high strength, appropriately sized hitch pin with a mechanical retainer and attach safety chains. Criss cross chains under tongue and secure to draw bar cage, mounting loops, or bumper frame.
- Adopt safe driving practices:
 - Keep brake pedals latched together at all times. **NEVER USE INDEPENDENT BRAKING WITH MACHINE IN TOW, LOSS OF CONTROL AND/OR UPSET OF UNIT CAN RESULT.**
 - Always drive at a safe speed relative to local conditions and ensure that your speed is low enough for an emergency stop. Keep speed to a minimum.
 - Reduce speed prior to turns to avoid risk of overturning.
 - Always keep tractor or towing vehicle in gear to provide engine braking when going downhill. Do not coast.
 - Do not drink and drive!
- Comply with state and local laws governing highway safety and movement of farm machinery.
- Use approved accessory lighting flags and necessary warning devices to protect operators of other vehicles on highway during transport. Various safety lights and devices are available from your dealer.
- Use of flashing amber lights is acceptable in most localities. However, some localities prohibit their use. Local laws should be checked for all highway lighting and marking requirements.
- When driving a tractor and sprayer under 20 mph (40 kph) day or night, use flashing amber warning lights and a slow moving vehicle (SMV) identification emblem.
- Plan your route to avoid heavy traffic.
- Be a safe and courteous driver. Always yield to oncoming traffic in all situations, including narrow bridges, intersections, etc.
- Be observant of bridge loading ratings. Do not cross bridges rated lower than gross weight at which you are operating.
- Watch for obstructions overhead and side to side while transporting.
- Always operate equipment in a position to provide maximum visibility at all times. Make allowances for increased length and weight of sprayer when making turns, stopping, etc.



REMEMBER

Your best assurance against accidents is a careful and responsible operator. If there is any portion of this manual or function you do not understand, contact your local authorized dealer or manufacturer.



PERFORMING MAINTENANCE

- Good maintenance is your responsibility. Poor maintenance is an invitation to trouble.
- Make sure there is plenty of ventilation. Never operate engine of towing vehicle in a closed building. Exhaust fumes may cause asphyxiation.
- Before working on this machine, stop towing vehicle, set brakes, disengage PTO and all power drives, shut off engine and **remove ignition key**.
- Be certain all moving parts and attachments have come to a complete stop before attempting to perform maintenance.
- Always use a safety support and block wheels. Never use a jack to support machine.
- Always use proper tools or equipment for job at hand.
- Use extreme caution when making adjustments.
- Follow torque chart on page 10 in this manual when tightening bolts and nuts.
- Never use your hands to locate a hydraulic leak on attachments. Use a small piece of cardboard or wood. Hydraulic fluid escaping under pressure can penetrate skin.
- Openings in skin and minor cuts are susceptible to infection from hydraulic fluid.
Without immediate medical treatment, serious infection and reactions can occur.
- When disconnecting hydraulic lines, shut off hydraulic supply and relieve all hydraulic pressure.
- Replace **all shields** and **guards** after servicing and before moving.
- After servicing, be sure all tools, parts and service equipment are removed.
- Do not allow grease or oil to build up on any step or platform.
- When replacing bolts refer to owners manual.
- Refer to bolt torque chart on page 12 for head identification marking.
- Where replacement parts are necessary for periodic maintenance and servicing, genuine factory replacement parts must be used to restore your equipment to original specifications. Manufacturer will not claim responsibility for use of unapproved parts or accessories and other damages as a result of their use.
- If equipment has been altered in any way from original design, manufacturer does not accept any liability for injury or warranty.
- A fire extinguisher and first aid kit should be kept readily accessible while performing maintenance on this sprayer.

BOLT TORQUE

TORQUE DATA FOR STANDARD NUTS, BOLTS, AND CAPSCREWS.

Tighten all bolts to torques specified in chart unless otherwise noted. Check tightness of bolts periodically, using bolt chart as guide. Replace hardware with same grade bolt.

NOTE: Unless otherwise specified, high-strength Grade 5 hex bolts are used throughout assembly of equipment.



Torque Specifications

Bolt Torque for Standard bolts *

"A"	GRADE 2		GRADE 5		GRADE 8	
	lb-ft	(N.m)	lb-ft	(N.m)	lb-ft	(N.m)
1/4"	6	(8)	9	(12)	12	(16)
5/16"	10	(13)	18	(25)	25	(35)
3/8"	20	(27)	30	(40)	45	(60)
7/16"	30	(40)	50	(70)	80	(110)
1/2"	45	(60)	75	(100)	115	(155)
9/16"	70	(95)	115	(155)	165	(220)
5/8"	95	(130)	150	(200)	225	(300)
3/4"	165	(225)	290	(390)	400	(540)
7/8"	170	(230)	420	(570)	650	(880)
1"	225	(300)	630	(850)	970	(1310)

Bolt Torque for Metric bolts *

"A"	CLASS 8.8		CLASS 9.8		CLASS 10.9	
	lb-ft	(N.m)	lb-ft	(N.m)	lb-ft	(N.m)
6	9	(13)	10	(14)	13	(17)
7	15	(21)	18	(24)	21	(29)
8	23	(31)	25	(34)	31	(42)
10	45	(61)	50	(68)	61	(83)
12	78	(106)	88	(118)	106	(144)
14	125	(169)	140	(189)	170	(230)
16	194	(263)	216	(293)	263	(357)
18	268	(363)	--	--	364	(493)
20	378	(513)	--	--	515	(689)
22	516	(699)	--	--	702	(952)
24	654	(886)	--	--	890	(1206)

Torque figures indicated are valid for non-greased or non-oiled threads and heads unless otherwise specified. Therefore, do not grease or oil bolts or capscrews unless otherwise specified in this manual. When using locking elements, increase torque values by 5%.

* GRADE or CLASS value for bolts and capscrews are identified by their head markings.

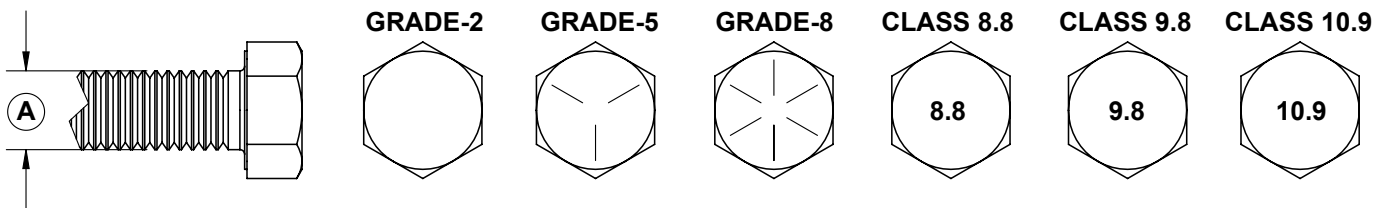

TANK AND TANK SKID MOUNTING

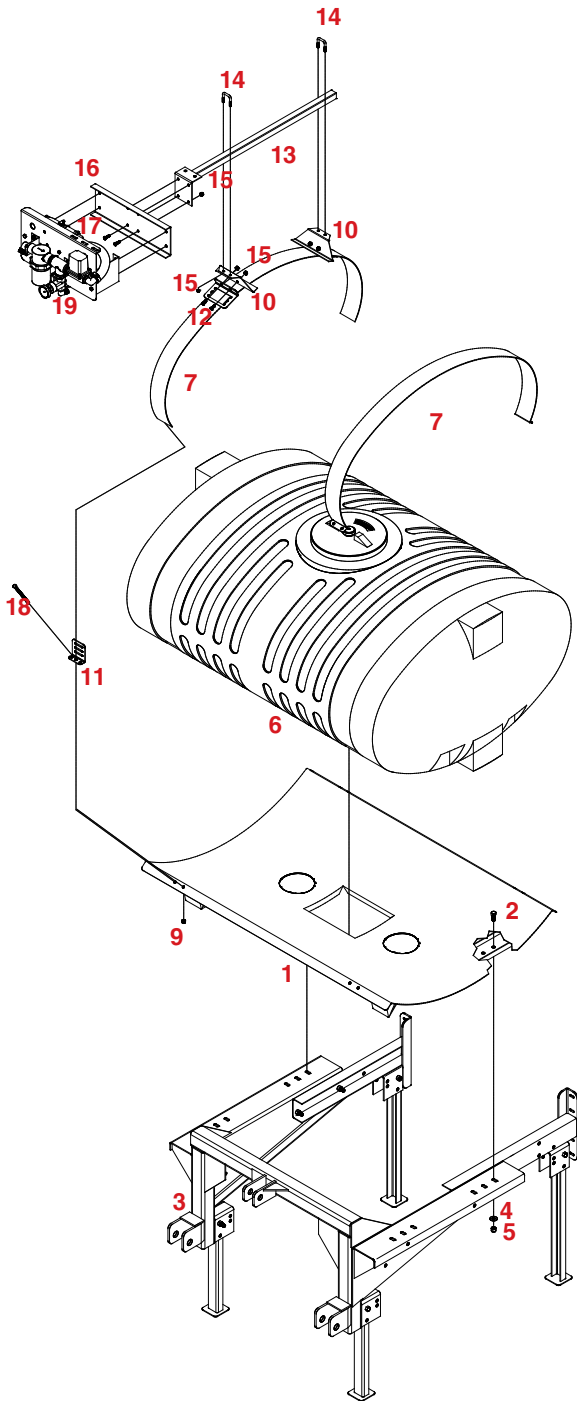

ASSEMBLY

1. Begin by fastening the tank skid (#1) to the mainframe (#3) using 1/2" x 1-1/4" hex head bolts (#2), 1/2" flatwashers (#4), and 1/2" locknuts (#5).
2. Fasten mounting plates (#10), and strap anchors (#11) to tank strap (#7) using 5/16" x 3/4" bolts (#12), and 5/16" locknuts (#15). Refer to page 2 for strap and strap anchor routing.
3. Place tank (#6) onto the tank skid (#1). Using tank straps (#7) fasten tank to skid with 3/8" x 6" hex head bolts (#18), and 3/8" locknuts (#9).
4. Fasten panel mount stem (#13) to the mounting plates (#10) using 5/16" sq. u-bolts (#14), and 5/16" locknuts (#15). Used when 3 section boom control is ordered.
5. Fasten panel mount plate (#16) to panel mount stem (#13) using 5/16" x 1" hex head bolts (#17), and 5/16" locknuts (#15).
6. Mount the control panel (#19) to the mounting plate (#16) using bolts included with control panel mounting package. REFER TO CONTROL PANEL MANUAL FOR PARTS BREAKDOWN AND INSTRUCTIONS.

NOTE: Do not let any agricultural chemical stand in the applicator tank when not in use. Chemicals left standing in equipment that is not in use, shorten the life of the tanks, pumps, hoses, etc. The longer the chemical stands, the more water evaporates and the stronger the chemical solution becomes.

LEGS, PLATFORM AND STEP MOUNTING

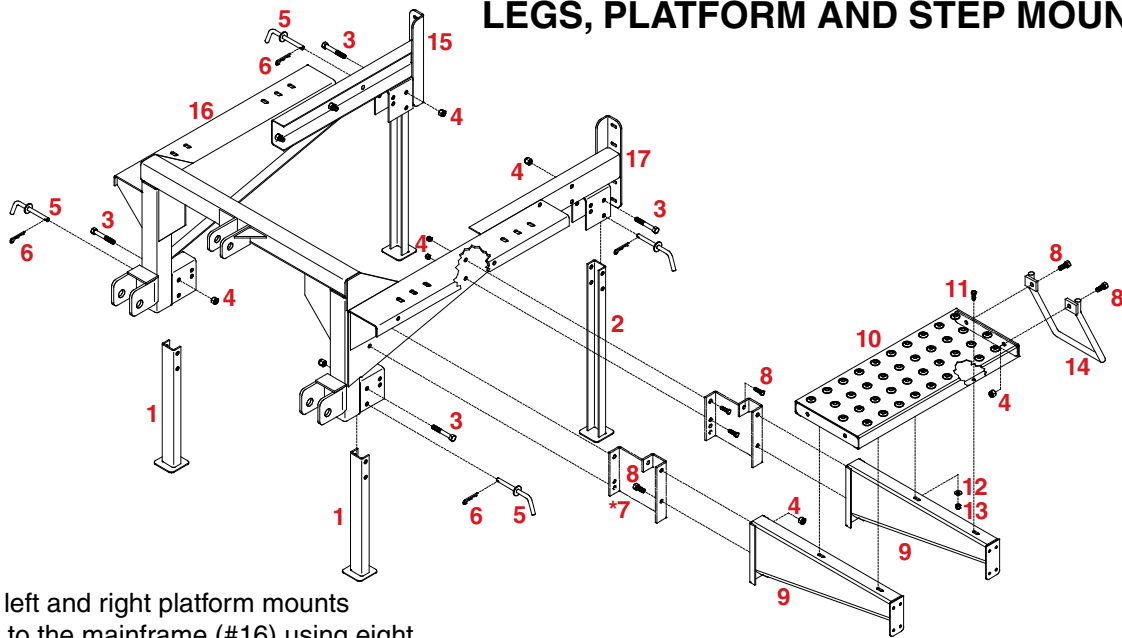

1. Fasten the left and right platform mounts (#15 & 17) to the mainframe (#16) using eight 1/2" x 1-1/4" Hex head bolts, and eight 1/2" locknuts.
2. Attach the front legs (#1) to the mainframe using 1/2" x 3-1/2" hex head bolts (#3) and 1/2" Locknuts (#4). Lock legs in lowered position using pin (#5) and hairpin (#6).
3. Attach the rear legs (#2) to the right and left platform mounts using 1/2" x 3-1/2" hex head bolts (#3) and 1/2" Locknuts (#4). Lock legs in lowered position using pin (#5) and hairpin (#6).
4. Attach platform brackets (#9) to the mainframe using 1/2" x 1-1/4" hex head bolts (#8) and 1/2" locknuts (#4). **NOTE: Extension brackets (*#7) are used on RMLE units only.**
5. Fasten platform (#10) to the platform brackets (#9) using 3/8" x 1-1/4" hex head bolts (#11), 3/8" flatwashers, and 3/8" locknuts (#13).
6. Attach step (#14) to the platform (#10) using 1/2" x 1-1/4" hex head bolts (#8), and 1/2" locknuts (#4).

HANDRAIL, MANUAL HOLDER, FRESH WATER TANK AND BOOM CARRIER

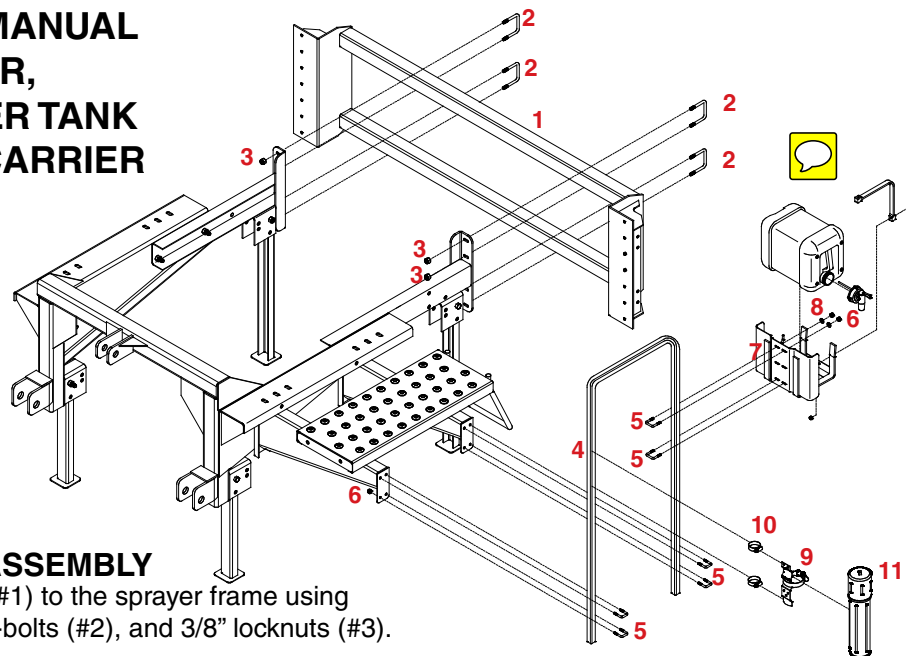

ASSEMBLY

1. Fasten boom carrier (#1) to the sprayer frame using 3/8" x 2-1/2" square u-bolts (#2), and 3/8" locknuts (#3).
2. Fasten handrail (#4) to the platform mounting brackets using 1/4" x 1" square u-bolts (#5), and 1/4" locknuts (#6).
3. Fasten canister bracket (#9) to the handrail (#4) using two 1" hose clamps (#10). Attach the manual canister (#11) to the canister bracket(#9).
4. Fasten fresh water tank bracket (#7) to the handrail tube (#4), using 1/4" x 1" square u-bolts (#5), 1/4" flatwasher (#8), and 1/4" locknuts (#6).

PARTS LIST

1.	03644-10	1	Boom Carrier
2.	01887	4	3/8"-16 UNC x 2-1/2" x 3-1/2" Sq. U-bolt
3.	02592	8	3/8"-16 UNC Nylon Insert Locknut

Please order replacement parts by **PART NO.** and **DESCRIPTION**

OPTIONAL REAR MOUNT EXTENSION BRACKET FOR FOAM MARKER (DFM 60)

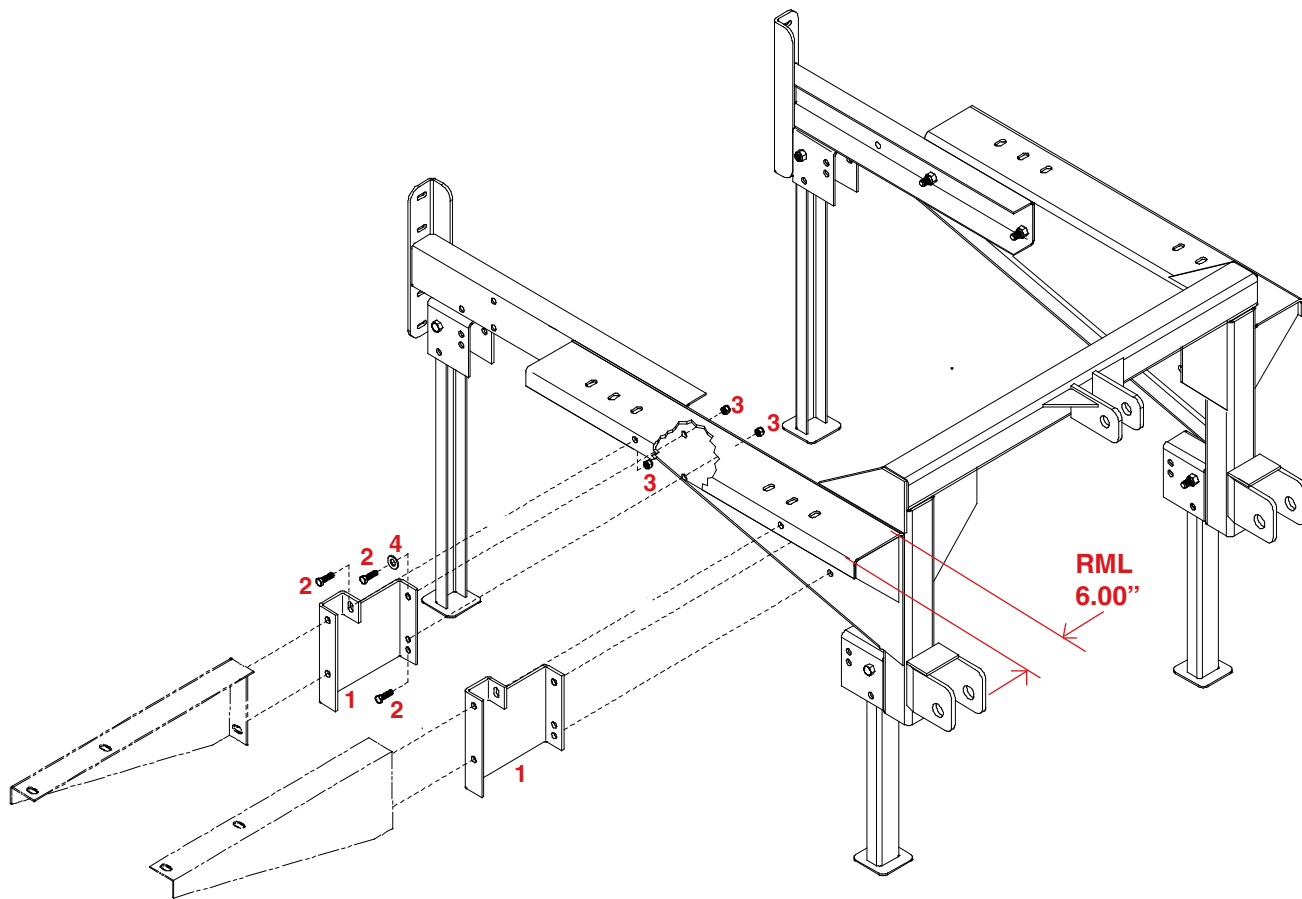

ASSEMBLY

1. Begin by bolting on the Extension Bracket (#1) using six 1/2" x 1-1/4" hex head bolts (#3) and nylon insert locknuts (#4).
2. Continue assembly with step 1 of DFM60 Foam Marker owners manual.

PARTS LIST

REF. NO.	PART NO.	QTY.	DESCRIPTION
1.	03746-10	2	Extension Bracket
2.	00967	6	1/2" x 1-1/4" Hex Head Bolts (Gr.5)
3.	02178	6	1/2" Nylon Insert Locknut
4.	00085	2	1/2" Flat Washer

Please order replacement parts by **PART NO.** and **DESCRIPTION.**

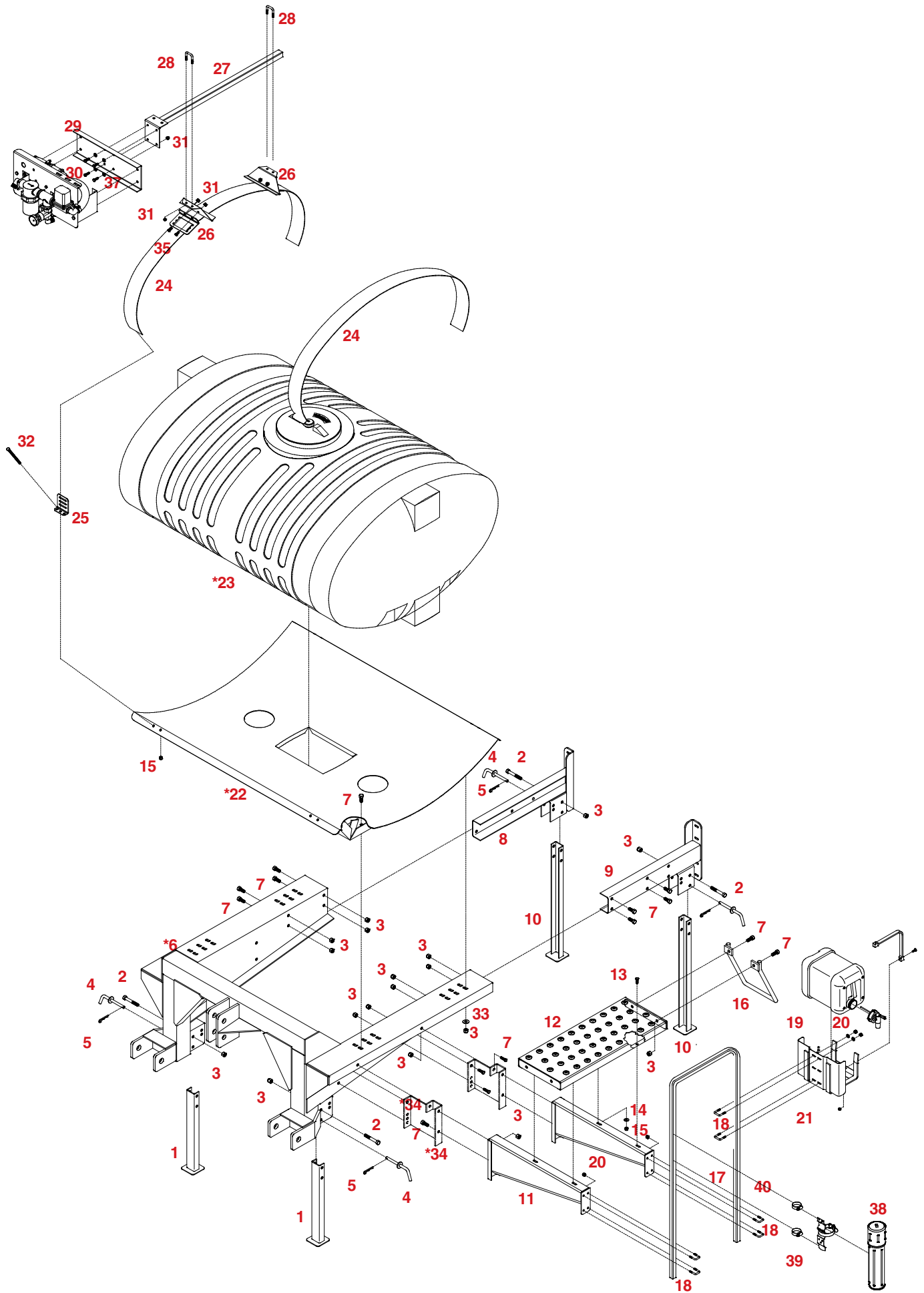

RMLE PARTS LIST

REF. NO.	PART NO.	QTY.	DESCRIPTION
1.	05387-10	2	Front Legs
2.	01897	4	1/2"-13 UNC x 3-1/2" Hex Hd. Bolt Gr.5
3.	02178	20	1/2"-13 UNC Nylon Insert Locknut
4.	01718-95	4	Pin
5.	00182	4	Hairpin
6.	05381-10	1	Mainframe (RMLE)
7.	00967	16	1/2"-13 UNC x 1-1/4" Hex Head Bolt Gr.5
8.	05396-10	1	Right Platform Mount
9.	05386-10	1	Left Platform Mount
10.	05388-10	2	Rear Leg
11.	07744-10	2	Platform Mounting Bracket
12.	07745-10	1	Platform Step
13.	00523	4	3/8"-16 UNC x 1-1/4" Hex Head Bolt Gr.5
14.	00059	4	3/8" Flatwasher
15.	02178	4	3/8"-16 UNC Nylon Insert Locknut
16.	00164-10	1	Step
17.	07746-10	1	Hand Rail
18.	04822	4	1/4"-20 UNC x 1" x 1-1/2" Sq. U-bolt
19.	00214	4	1/4" Flatwasher
20.	02772	18	1/4"-20 UNC Nylon Insert Locknut
21.	05615-30	1	Freshwater Tank Bracket
22.	02882-10	1	Tank Skid (400 gal. Elliptical (RMLE))
-	02130-10	1	Tank Skid (500 gal. Elliptical (RMLE))
23.	PE400 RA	1	400 gal. Elliptical Tank (RMLE)
-	PE500 RA	1	500 gal. Elliptical Tank (RMLE)
24.	**03728	2	4" Tank Strap
25.	05784-95	6	Large Strap Anchor (4")
26.	03712-10	2	Mounting Bracket for Elliptical Tank Panel Stem
27.	05391-10	1	Panel Mount Stem
28.	00909	2	5/16"-18 UNC x 1-1/4" Sq. U-bolt
29.	04936-30	1	Panel Mount Plate (included with plumbing kit)
30.	02990	4	5/16"-18 UNC x 1" Hex Head Bolt (not included)
31.	02802	8	5/16"-18 UNC Nylon Insert Locknut
32.	02157	8	3/8"-16 UNC x 6" Full Thread Hex Head Bolt Gr.5
33.	00085	4	1/2" Flatwasher
34.	03746-10	2	Platform Extension Bracket (used on RMLE only)
35.	01263	4	5/16"-18 UNC x 3/4" Hex Head Bolt
37.	00004	4	5/16 Flat Washer
38.	10241	1	Owners Manual Canister
39.	10242	1	Canister Bracket
40.	B16H	2	1" Hose Clamp
--	AB21002	1	Replacement Warning Store Empty Decal
--	AB21001	1	Replacement Warning Do Not Ride or Stand Decal
--	AA21027	2	Replacement "Demco" Decal
--	AA21014	1	Replacement Fresh Water Decal
--	AB21014	1	Replacement Warning Wear Protective Clothing Decal
--	AA21002	2	Replacement "Boyden, Iowa" Decal

Please order replacement parts by **PART NO.** and **DESCRIPTION.**

****Straps are sold per foot. See Page 19 for proper strap length.**

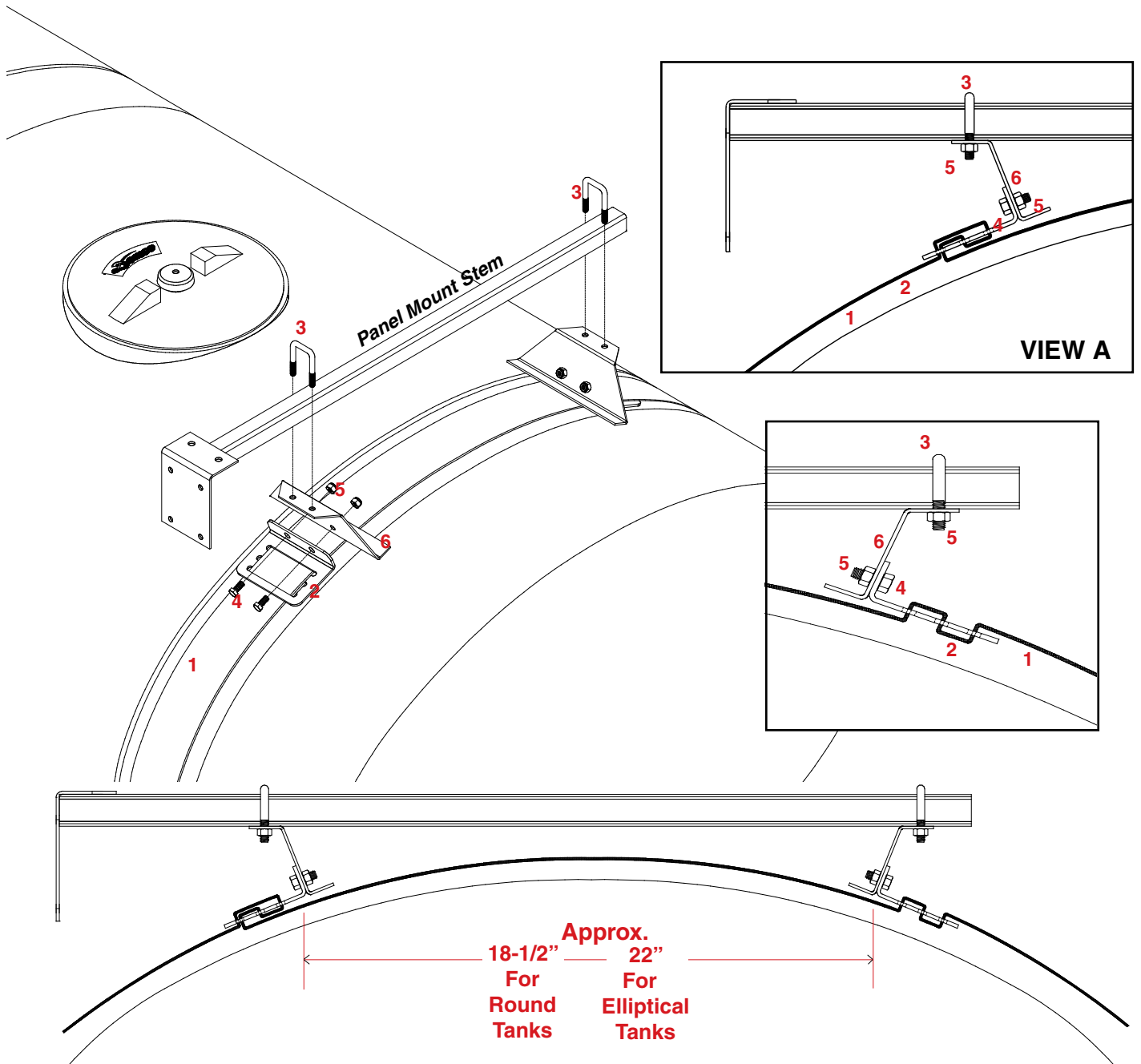

INSTALLATION

1. Locate the center of the strap (#1) by folding it in half. Mark the strap approximately, 11" for elliptical tanks and 9-1/4" for round tanks, from both sides of center. This is where the 90° bend angle of the anchors (#2) will be located. Weave strap through one anchor using method shown in, note the direction of the anchors, and mount the other anchor as shown in.
2. Place strap and anchors over band area on tank. Locate the anchor shown in towards the side of the tank where the panel will be mounted. Install anchors on the strap ends as shown on opposite side of this sheet.
3. Attach the panel mounts (#6) to the anchors (#2) using four 5/16" x 3/4" bolts (#4) and locknuts (#5), as shown. Attach the panel mount stem to strap mounts (#6) using two 5/16" x 1-1/4" square u-bolts (#3) and locknuts.

REF. NO.	PART NO.	QTY.	DESCRIPTION
1.	-	2	Polyester Strap
	05367	-	1-3/4"-Black Strap
	03728	-	4"-Black Strap
2.	-	2	Strap Anchor
	05785-95	2	Small Strap Anchor (1-3/4")
	05784-95	2	Large Strap Anchor (4")
3.	00909	2	5/16"-18 UNC x1-1/4" Square U-bolt
4.	01263	4	5/16"-18 UNC x 3/4" Hex Head Bolt
5.	02802	8	5/16"-18 UNC Nylon Insert Locknut
6.	03712-10	2	Mounting Plate for Elliptical Tank
-	03713-10	2	Mounting Plate for Round Tank

Please order replacement parts by **PART NO.** and **DESCRIPTION.**

Polyester Tank Bands for Demco Tanks

Attaching Hardware for Strap Bands

REF. NO.	PART NO.	QTY.	DESCRIPTION
1.	-	2	Polyester Strap
	05367	-	1-3/4"-Black Strap (Sold per foot)
	03728	-	4"-Black Strap (Sold per foot)
2.	-	2	Strap Anchor
	05785-95	2	Small Strap Anchor (1-3/4")
	05784-95	2	Large Strap Anchor (4")
3.	04352	2	5/16"-18 UNC x 4" Full Thread Bolt
-	02802	2	5/16"-18 UNC Nylon Insert Locknut
3.	01885	2	3/8"-16 UNC x 5" Full Thread Bolt
3.	02157	2	3/8"-16 UNC x 6" Full Thread Bolt
-	02592	2	3/8"-16 UNC Nylon Insert Locknut

INSTALLATION

To replace the old style steel tank bands with new polyester straps, remove the steel bands and use the bolts that secured them to attach the new straps.

Weave the straps (#1) through the Strap Anchors (#2) as shown in *Allow a minimum of 2" overlap past the anchor on the tank side of strap.

VIEW A

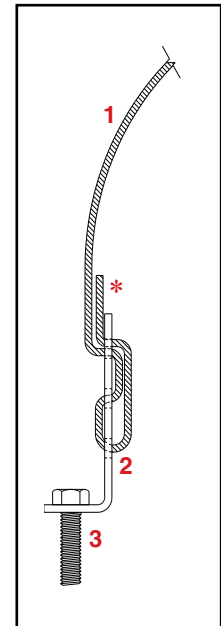

Please order replacement parts by PART NO. and DESCRIPTION.

NOTE: Be sure to center the straps and make final adjustments before tightening them down with the bolts.

NOTE: Be sure to check the straps periodically to ensure they are tight.

STRAP		PART NO.	LENGTH INCHES USED PER BAND	TANKS
WIDTH	COLOR			
1-3/4"	Black	*05367	50"	Planter Tanks P25 23, P55 23, P85 24, P110 24
			64"	Planter Tanks P110 30, P150 30
			56"	150-250 gallon Cutaway tanks (Short side one per tank)
			74"	150-250 gallon Cutaway tanks (Tall side one per tank)
			60"	200 gallon P200 32
			86"	200 gallon elliptical PE200R
			50"	Lawn & Garden Line tanks P55 23, P85 24
			64"	110, 150 gallon Rear Mount tanks P110 30, P150 30
			86"	300 gallon PE300R, P300 38
			4"	Black
112"	400 & 500 gallon PE400R, PE500R , 750 gallon PE750DA			
94"	500 & 600 gallon PE500A, PE600A & S48, PS548A (saddles)			
108"	TMC 500 gallon SKD"48"			
126"	750 gallon PE750A , 1000 gallon PE1000DA			
130"	1000 & 1600 gallon elliptical tank P1000A and PS-1016E (skid)			
126"	60" dia. round tanks SKD"60" (skid)			
150"	72" dia. round tanks SKD"72" (skid)			

* Strap only sold by the Linear Foot

Locate tank, locate inches of material needed per band, multiply that length by the number of bands needed
 _____ = number of linear feet needed
 divide by 12

Please order replacement polyester strap material by PART NO., DESCRIPTION and by the LINEAR FOOT. Specify the tank to be fit and material will be cut to length before shipment.

DB AND DFBII BOOM MOUNTING BRACKET KIT (9416004)

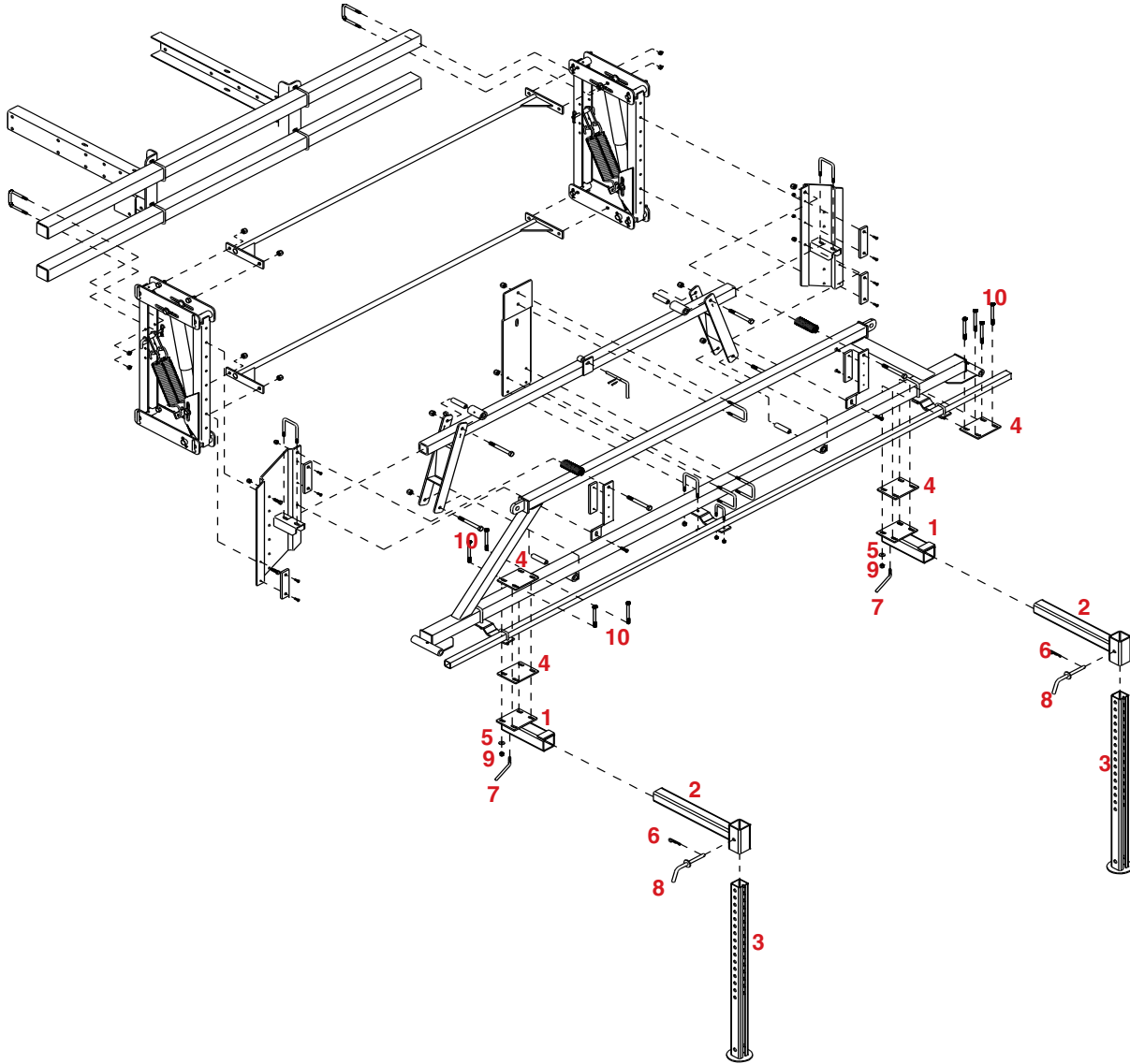

DB AND DFBII GROUND STAND PARTS LIST

REF. NO.	PART NO.	QTY.	DESCRIPTION
1.	07650-30	2	Ground Stand Receiver Tube
2.	07651-30	2	Ground Stand Insert Tube
3.	07735-30	2	Adjustable Leg
4.	07653-30	4	Back-up Plate
5.	00059	16	3/8" Flat Washer
6.	00182	4	Hair pin
7.	01404-95	2	Locking Handle
8.	01718-95	4	Locking Pin
9.	02592	12	3/8" Nylon Insert Locknut
10.	02769	8	3/8" x 4" Hex Head Bolt(Gr.5)

Please order replacement parts by PART NO. and DESCRIPTION.

GROUND STORAGE STANDS FOR X-FOLD MOUNTING

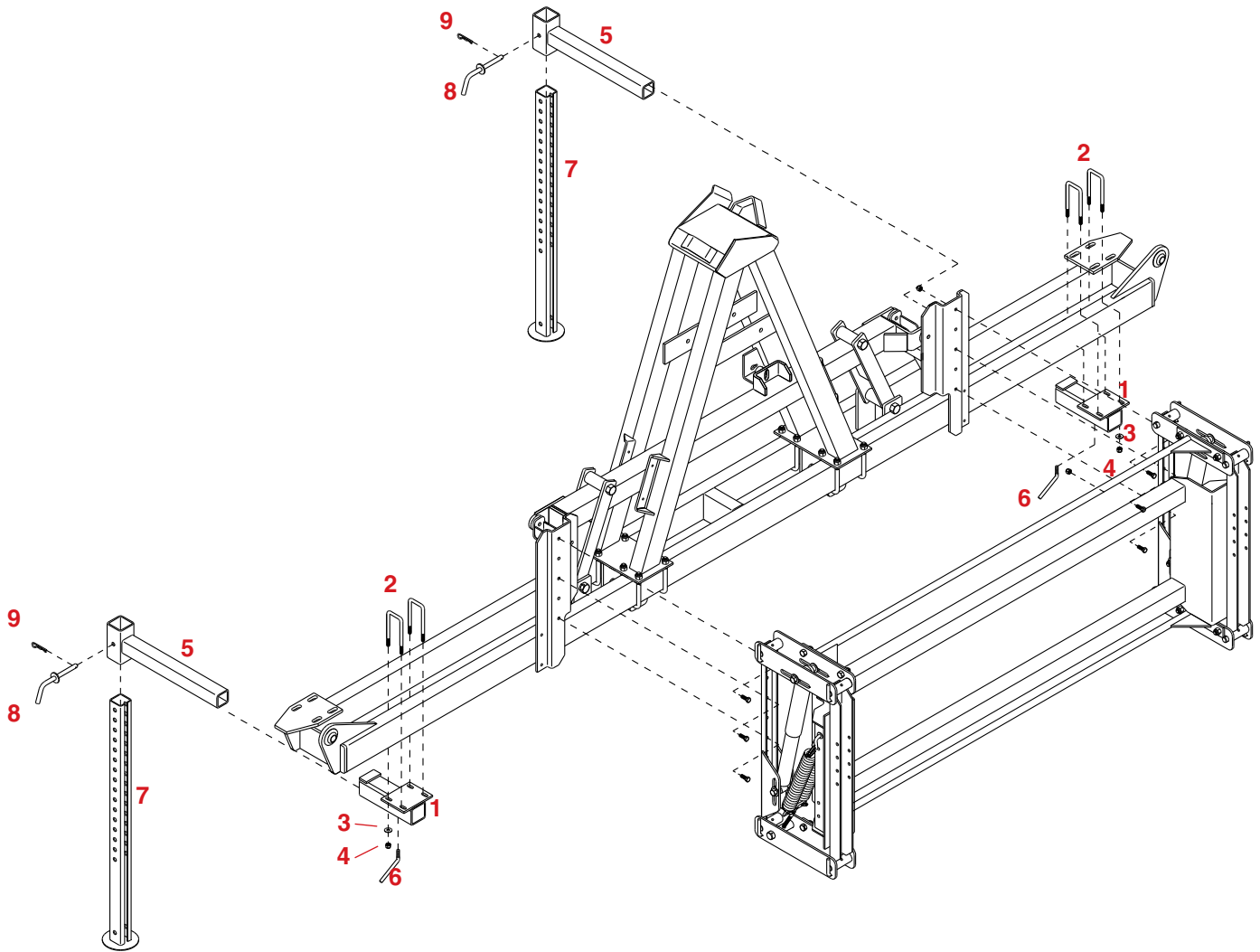

STORAGE STANDS ASSEMBLY INSTRUCTIONS

The Flotation Boom Mount and 3-Point Mount must be assembled before proceeding.

1. Mount the Rear Leg Receiver Tube (#1) to the bottom of the Center Tube Assembly using two 3/8" Square U-Bolts (#2), four 3/8" Flatwashers (#3) and four 3/8" Locknuts (#4).
2. Insert the Rear Insert Tube (#5) and secure using a 3/8" Locking Bolt (#6)
3. Insert the Adjustable Legs (#7) and secure using a Locking Pin (#8) and Hair Pin (#9)

Repeat on other side.

9488011 PARTS LIST

1.	07650-30	2	Rear Leg Receiver Tube
2.	05583	4	3/8"-16 UNC x 2-1/8" x 4-7/8" Square U-bolt
3.	00059	8	3/8" Flatwasher
4.	02592	12	3/8"-16 UNC Nylon Insert Locknut
5.	07651-30	2	Rear Insert Tube
6.	01404-95	2	Locking Bolt
7.	07735-30	4	Adjustable Leg
8.	01718-95	4	Lock Pin
9.	00182	4	.125 Hair Pin

Please order replacement parts by PART NO. and DESCRIPTION.

TWO AND THREE POINT HITCH INSTRUCTIONS

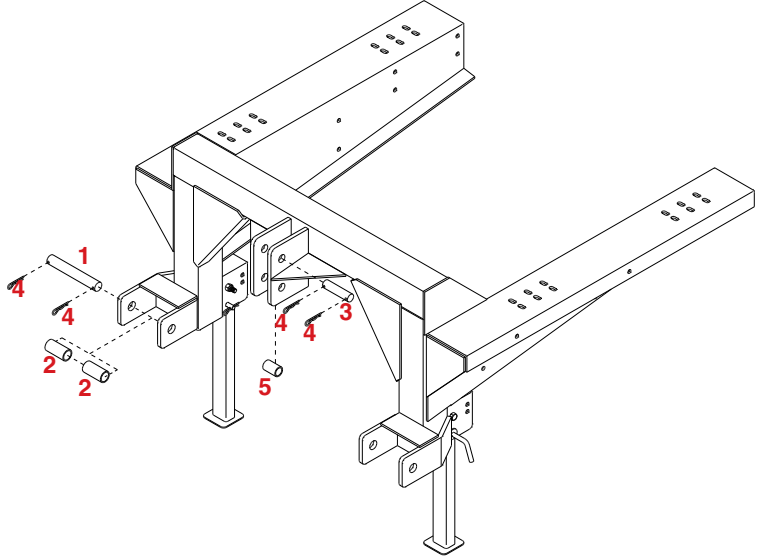
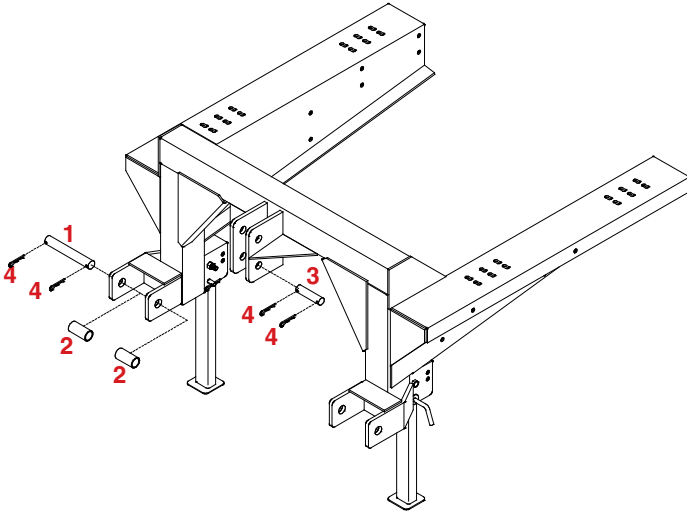

CATEGORY II HITCH MODEL RMSE PARTS LIST

REF. NO.	PART NO.	QTY.	DESCRIPTION
1.	05382-95	2	1-1/8" x 7-3/4" Pin
2.	00328-95	4	1-7/16 "O.D x 1-3/16" I.D x 3" lg. Bushing
3.	00332-95	1	1" Dia. x 4" Pin
4.	00006	6	3/16" Hairpin

Please order replacement parts by **PART NO.** and **DESCRIPTION.**

CATEGORY III HITCH MODEL RMLE PARTS LIST

REF. NO.	PART NO.	QTY.	DESCRIPTION
1.	05382-95	2	1-1/8" x 7-3/4" Pin
2.	00328-95	4	1-7/16 "O.D x 1-3/16" I.D x 3" lg. Bushing
3.	00332-95	1	1" Dia. x 4" Pin
4.	00006	6	3/16" Hairpin
5.	05383-95	1	1-1/4" O.D x 1" I.D x 1-15/16" Bushing

Please order replacement parts by **PART NO.** and **DESCRIPTION.**

Plumbing Kit for Front/Rear Mounts 9470004 - Single Section Control

See Control Panel Owners Manual for Hook-Up & Operation

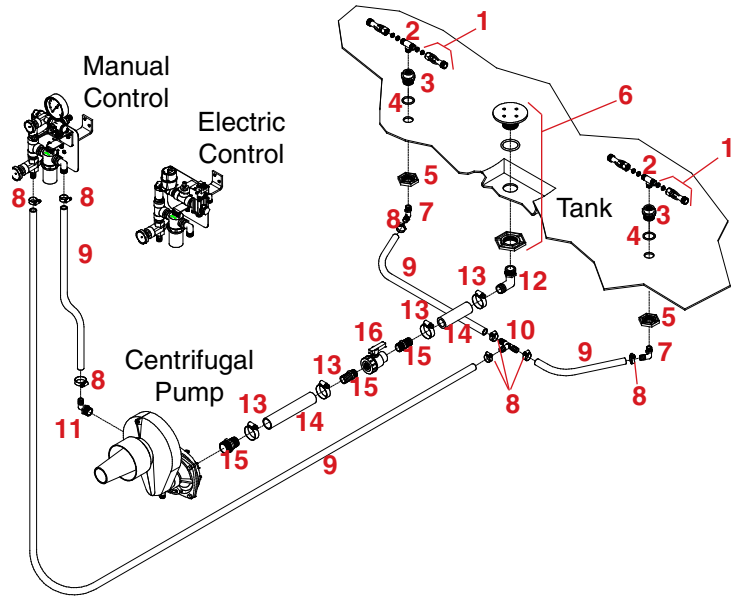

PLUMBING PARTS LISTS

REF. NO.	PART NO.	QTY.	DESCRIPTION
-	D3371P	2	Agitation Assembly
1.	*5044 1	2	Jet Agitation Wand Assembly
2.	*R1212	1	Jet Agitation Tee Fitting
3.	*P012D	1	Jet Agitation Fitting
4.	*5077V	1	Jet Agitation O-Ring
5.	N5P	1	Jet Agitation Nut
6.	P114PAV	1	1-1/4" Anti-Vortex Tank Outlet Assembly
7.	BEL1234	2	1/2" MPT x 3/4" Elbow Fitting (GFP)

* These items sold as complete part only (D3371P).

8.	B12H	8	3/4" SS Gear Clamp
9.	340RB	-	3/4" I.D. Rubber Hose
10.	T34	1	3/4" Tee
11.	BEL1034	1	1" MPT x 3/4" Hose Barb Elbow Fitting (GFP)
12.	BEL114	3	1-1/4" MPT x 1-1/4" Hose Barb Elbow Fitting(GFP)
13.	B24H	10	1-1/4" SS Gear Clamp
14.	1140RB	-	1-1/4" I.D. Rubber Hose
15.	BA114	4	1-1/4" MPT x 1-1/4" Hose Barb Fitting (GFP)
16.	UV125FP	2	1-1/4" Nylon Ball Valve

Please order replacement parts by **PART NO.** and **DESCRIPTION.**

Plumbing Kit for Front/Rear Mounts

9470005 - 3 Section Control

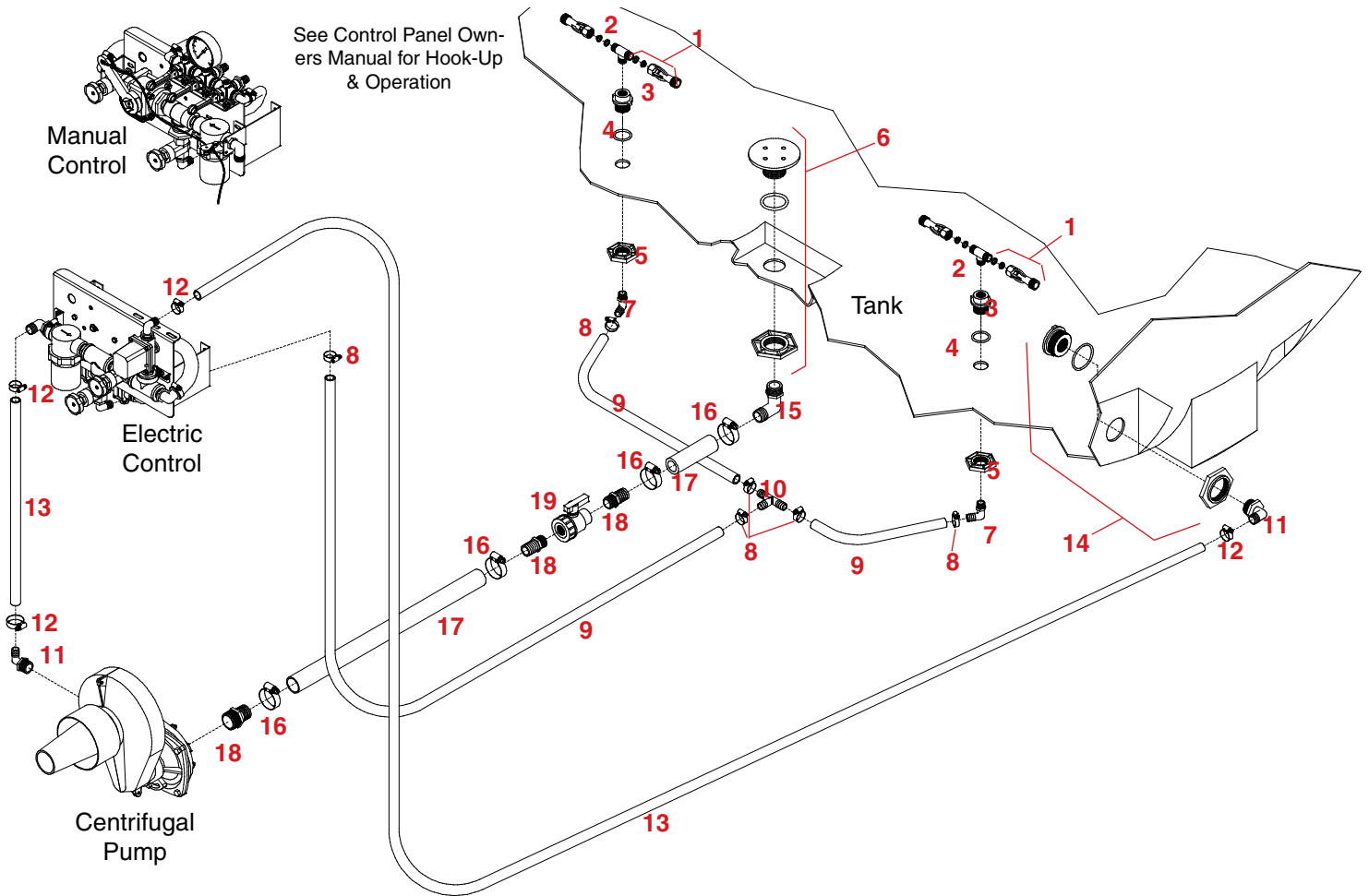

See Control Panel Owners Manual for Hook-Up & Operation

PLUMBING PARTS LISTS

REF. NO.	PART NO.	QTY.	DESCRIPTION
-	D3371P	2	Agitation Assembly
1.	*5044 1	2	Jet Agitation Wand Assembly
2.	*R1212	1	Jet Agitation Tee Fitting
3.	*P012D	1	Jet Agitation Fitting
4.	*5077V	1	Jet Agitation Viton O-Ring
5.	*N5P	1	Jet Agitation Nut
6.	P114PAV	1	1-1/4" Anti-Vortex Tank Outlet Assembly
7.	EL1234	2	1/2" MPT x 3/4" Elbow Fitting (GFP)
8.	B12H	8	3/4" SS Gear Clamp
9.	340RB	-	3/4" I.D. Rubber Hose
10.	T34	1	3/4" Tee
11.	BEL114 1	1	1-1/4" MPT x 1" Hose Barb Elbow Fitting (GFP)
12.	B16 H	4	1" SS Gear Clamp
13.	1010RB	-	1" I.D. Rubber Hose
14.	P100	1	1" Tank Fitting Assembly
15.	BEL114	3	1-1/4" MPT x 1-1/4" Hose Barb Elbow Fitting GFP)
16.	B24H	10	1-1/4" SS Gear Clamp
17.	1140RB	-	1-1/4" I.D. Rubber Hose
18.	BA114	4	1-1/4" MPT x 1-1/4" Hose Barb Fitting (GFP)
19.	UV125FP	2	1-1/4" Nylon Ball Valve

Please order replacement parts by **PART NO.** and **DESCRIPTION.**
 * These items sold as complete unit only (D3371P).

SPRAYER CHECKLIST:

Downtime caused by field breakdowns is costly and time consuming. Many breakdowns can be eliminated by periodic equipment maintenance. By spending time reviewing this checklist before seasonal spraying application time and following proper after-season care, you can save time and money later.



WARNING: To Prevent Serious Injury Or Death

- Keep hands, feet, and loose clothing away from rotating parts.
- Wear protective clothing recommended by your chemical and fertilizer manufacturer when working with chemicals.

Check Before Going To The Field :

1. NOZZLES

Check tip for excessive wear by checking for grooves in or near tip opening. Check nozzle spacing by starting at center and working outwards. Check boom for proper height.

2. HOSES

Check all hoses for worn or soft spots. Be sure all hose clamps are tightened and hoses are not kinked or pinched. Check for leakage in any lines.

3. TANK

Remove and clean agitator orifices. Check orifices for excessive wear by checking for grooves in or near orifice opening. Inspect fitting and grommets to insure they are in good condition.

4. CONTROLS

Check for leakage, plugging, or wear on all valves, fittings, etc. Clean off any build up of foreign material.

5. PUMP

Check to be sure pump turns freely.

6. FRAME

Be sure all bolts are tightened.

7. REPLACEMENT PARTS

Replace all worn or damaged parts.

After Season Care:

NOTE: It is important to wear proper safety equipment when cleaning the sprayer. See your chemical or fertilizer package for this information.

1. After spraying chemicals, run water mixed with cleaners through tank, pump and all hose hookups. If wettable powder dries out in the system, it is very difficult to put back into suspension and can cause malfunction, damage or injury.
2. When cleaned, tank should have all openings closed or covered to keep dirt from entering.
3. Pump should be flushed with soluble oil and pump ports plugged to keep out moisture and air.
4. Disassemble tips and rinse with water or cleaning solution. (Appropriate for chemical sprayed).
5. Clean tip opening with a wooden toothpick. Never use wire or hard object that could distort opening.
6. Dispose of all unused chemicals or solutions in a proper and ecologically sound manner.
6. Water rinse and dry tips before storing.

NOTE: DEMCO does not and will not make any recommendations concerning application of various chemicals or solutions. These recommendations relate to either amount or procedure of materials applied. If you have any questions regarding application of certain chemicals or solutions, contact your chemical supplier and follow chemical manufacturer recommendations.



P.O. BOX 189
4010 320th St., BOYDEN, IA. 51234
PH: (712) 725-2311 or (712) 725-2302
FAX: (712) 725-2380
TOLL FREE: 1-800-54DEMCO (1-800-543-3626)
www.demco-products.com