

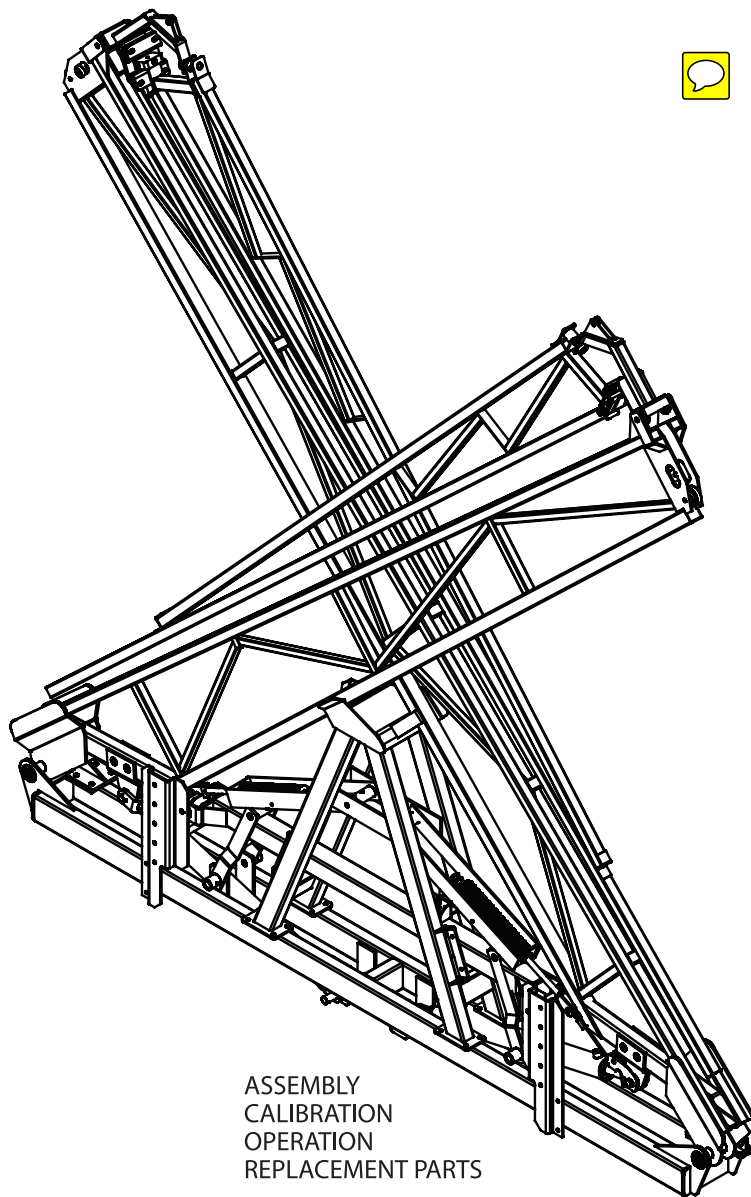

Demco

Hydraulic X-Fold

45' & 60' Boom



ASSEMBLY
CALIBRATION
OPERATION
REPLACEMENT PARTS

READ *complete manual CAREFULLY
BEFORE attempting operation.*

Doing Our Best to Provide You the Best

OPERATORS MANUAL

Thank you for purchasing a Demco sprayer boom. We feel you have made a wise choice and hope you are completely satisfied with your new sprayer boom. If you have any questions regarding the applications of certain solutions or chemicals, contact your chemical supplier and follow chemical manufacturer recommendations as well as all licensing and use restrictions or regulations.



WARNING: TO AVOID PERSONAL INJURY OR PROPERTY DAMAGE, OBSERVE FOLLOWING INSTRUCTIONS:

Chemicals are dangerous. Know exactly what you're going to do and what is going to happen before attempting to work with these products. Improper selection or use can injure people, animals, plants and soil.

Always wear protective clothing such as coveralls, goggles and gloves when working with chemicals or sprayer.

Be sure to dispose of all unused chemicals or solutions in a proper and ecologically sound manner.

GENERAL INFORMATION

1. Unless otherwise specified, high-strength (grade5) (3 radial-line head markings) hex head bolts are used throughout assembly of this sprayer.
2. Whenever terms “**LEFT**” and “**RIGHT**” are used in this manual it means from a position behind sprayer and facing forward.
3. When placing a parts order, refer to this manual for proper part numbers and place order by **PART NO., DESCRIPTION, and COLOR.**

Table of Contents

General information	2
Warranty Registration	3-4
Safety Pages	5-11
Safety Sign Locations.....	7
Bolt Torque.....	12
Center Section Parts Breakdown & Parts List	13
Center Section Assembly Instructions.....	14
3-Point Assembly Parts Breakdown, Parts List, & Assembly Instructions	15
Wing Assembly Instructions	16
Wing Parts Breakdown and Parts List.....	16-17
Trailer, Conquest, & Rear Mount Parts Breakdown, Parts List, & Assembly Instructions.....	18
Rear Mount Parts Breakdown, Parts List, & Assembly Instructions	19
Ground Storage Stands Parts Breakdown, Parts List, & Assembly Instructions	20
Auto Level Support Bar Kit Parts Breakdown ,Parts List and Assembly Instructions	21
Hydraulic Height Adjustment Parts Breakdown, Parts List, & Assembly Instructions.....	22
2 Cylinder Hydraulic's Parts Breakdown & Parts List	23
3 Cylinder Hydraulic's Parts Breakdown & Parts List	24
Control Box Parts Breakdown & Parts List.....	25
Wheel Tip Protector Parts Breakdown & Parts List	26
Tip Placement.....	26
Plumbing & Hose Routing	27
TeeJet 3-Way and TeeJet Single Nozzle Parts Breakdowns & Parts Lists	28
X-Fold Boom Operation Instructions	29
Sprayer Calibration Procedure	30
Sprayer Checklist.....	31



Warranty Registration

4010 320th Street • Box 189 • Boyden, Iowa 51234
Toll Free 800-54DEMCO (800-543-3626) • FAX 800-845-6420
www.demco-products.com

Ag	<input type="radio"/>
RV	<input type="radio"/>
Rental	<input type="radio"/>
Brakes	<input type="radio"/>
Marine	<input type="radio"/>

	Very Satisfied	Satisfied	Dissatisfied	Very Dissatisfied
How satisfied are you with our product?	<input type="radio"/>	<input type="radio"/>	<input type="radio"/>	<input type="radio"/>
How satisfied are you with the dealership/distributor sales staff? Dealer/Distributor Name _____ City _____ State _____	<input type="radio"/>	<input type="radio"/>	<input type="radio"/>	<input type="radio"/>
How satisfied are you with the company sales staff?	<input type="radio"/>	<input type="radio"/>	<input type="radio"/>	<input type="radio"/>
How satisfied are you with the delivery?	<input type="radio"/>	<input type="radio"/>	<input type="radio"/>	<input type="radio"/>
Did you have any contact with a Demco Representative? If YES , how satisfied were you?	YES <input type="radio"/>	NO <input type="radio"/>	<input type="radio"/>	<input type="radio"/>
I would recommend this product to my family and friends.	YES	NO		
Would you purchase again from DEMCO?	YES	NO		
Since taking delivery, have you been contacted by the dealer?	YES	NO		
Did you have any problems with this DEMCO product? If YES , are you satisfied with the company's resolution of your problem?	YES <input type="radio"/>	NO <input type="radio"/>	<input type="radio"/>	<input type="radio"/>

Please list the specific source of information prompting this purchase.

After purchasing this product, do you see any needed product improvement? _____ If yes, what improvement? _____

What other products would you like to see DEMCO offer? _____

Comments _____

Owner's Name: _____ Mailing Address: _____

City: _____ State: _____ Zip Code: _____

Model#: _____

Serial #: _____

Purchase Date: _____

Owner's Signature: _____

Please return to DEMCO By FAX or tri-folding this form to the backside, it is pre-addressed.

Postage

*Demco
4010 320th Street, Box 189
Boyden, Iowa 51234*

SAFETY

TAKE NOTE! THIS SAFETY ALERT SYMBOL FOUND THROUGHOUT THIS MANUAL IS USED TO CALL YOUR ATTENTION TO INSTRUCTIONS INVOLVING YOUR PERSONAL SAFETY AND THE SAFETY OF OTHERS. FAILURE TO FOLLOW THESE INSTRUCTIONS CAN RESULT IN INJURY OR DEATH.



THIS SYMBOL MEANS

-ATTENTION

-BECOME ALERT

-YOUR SAFETY IS INVOLVED!

SIGNAL WORDS

Note the use of the following signal words **DANGER**, **WARNING**, and **CAUTION** with the safety messages. The appropriate signal word for each has been selected using the following guidelines:

DANGER:

Indicates an imminently hazardous situation that, if not avoided, will result in death or serious injury. This signal word is to be limited to the most extreme situations typically for machine components which, for functional purposes, cannot be guarded.

WARNING:

Indicates a potentially hazardous situation that, if not avoided, could result in death or serious injury, and includes hazards that are exposed when guards are removed. It may also be used to alert against unsafe practices.

CAUTION:

Indicates a potentially hazardous situation that, if not avoided, may result in minor or moderate injury. It may also be used to alert against unsafe practices.

If you have questions not answered in this manual, require additional copies, or if your manual is damaged, please contact your dealer or DEMCO, P.O. Box 189, 4010 320th Street, Boyden, IA 51234
ph: (712) 725-2311 Toll Free: 1-800-543-3626 Fax: (712) 725-2380 www.demco-products.com



SAFETY...YOU CAN LIVE WITH IT



EQUIPMENT SAFETY GUIDELINES

Every year many accidents occur which could have been avoided by a few seconds of thought and a more careful approach to handling equipment. You, the operator, can avoid many accidents by observing the following precautions in this section. To avoid personal injury, study the following precautions and insist those working with you, or you yourself, follow them.

In order to provide a better view, certain illustrations in this manual may show an assembly with a safety shield removed. However, equipment should never be operated in this condition. Keep all shields in place. If shield removal becomes necessary for repairs, replace the shield prior to use.

Replace any caution, warning, danger or instruction safety decal that is not readable or is missing. Location of such decals is indicated in this booklet.

Do not attempt to operate this equipment under the influence of alcohol or drugs.

Review the safety instructions with all users annually.

Operator should be a responsible adult. **DO NOT ALLOW PERSONS TO OPERATE OR ASSEMBLE THIS UNIT UNTIL THEY HAVE DEVELOPED A THOROUGH UNDERSTANDING OF THE SAFETY PRECAUTIONS AND HOW IT WORKS.**

To prevent injury or death, use a tractor equipped with a roll over protective system (ROPS). Do not paint over, remove, or deface any safety signs or warning decals on your equipment. Observe all safety signs and practice the instructions on them.

Never exceed the limits of a piece of machinery. If it's ability to do a job, or to do so safely is in question-**DON'T TRY IT.**



LIGHTING AND MARKING

It is the responsibility of the customer to know the lighting and marking requirements of the local highway authorities and to install and maintain the equipment to provide compliance with the regulations. Add extra lights when transporting at night or during periods of limited visibility.

Lighting kits are available from your dealer or from the manufacturer.



SAFETY SIGN CARE

- Keep safety signs clean and legible at all times.
- Replace safety signs that are missing or have become illegible.
- Replaced parts that displayed a safety sign should also display the current sign.
- Safety signs are available from your distributor, dealer parts department, or the factory.

How to install safety signs:

- Be sure that the installation area is clean and dry.
- Decide on the exact position before you remove the backing paper.
- Remove the smallest portion of the split backing paper.
- Align the decal over the specified area and carefully press the small portion with the exposed sticky backing in place.
- Slowly peel back the remaining paper and carefully smooth the remaining portion of the decal into place.
- Small air pockets can be pierced with a pin and smoothed out using the piece of decal backing paper.



SAFETY SIGN LOCATIONS

Types of safety sign and locations on equipment are shown in illustration below. Good safety requires that you familiarize yourself with various safety signs, type of warning, and area or particular function related to that area, that requires your SAFETY AWARENESS.

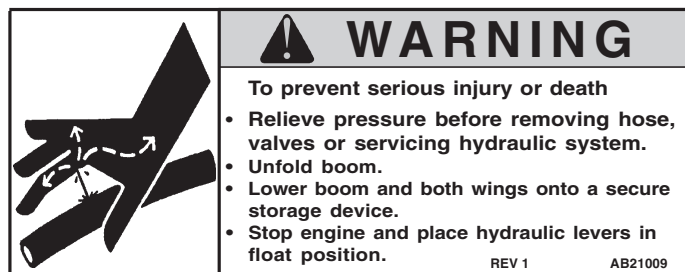
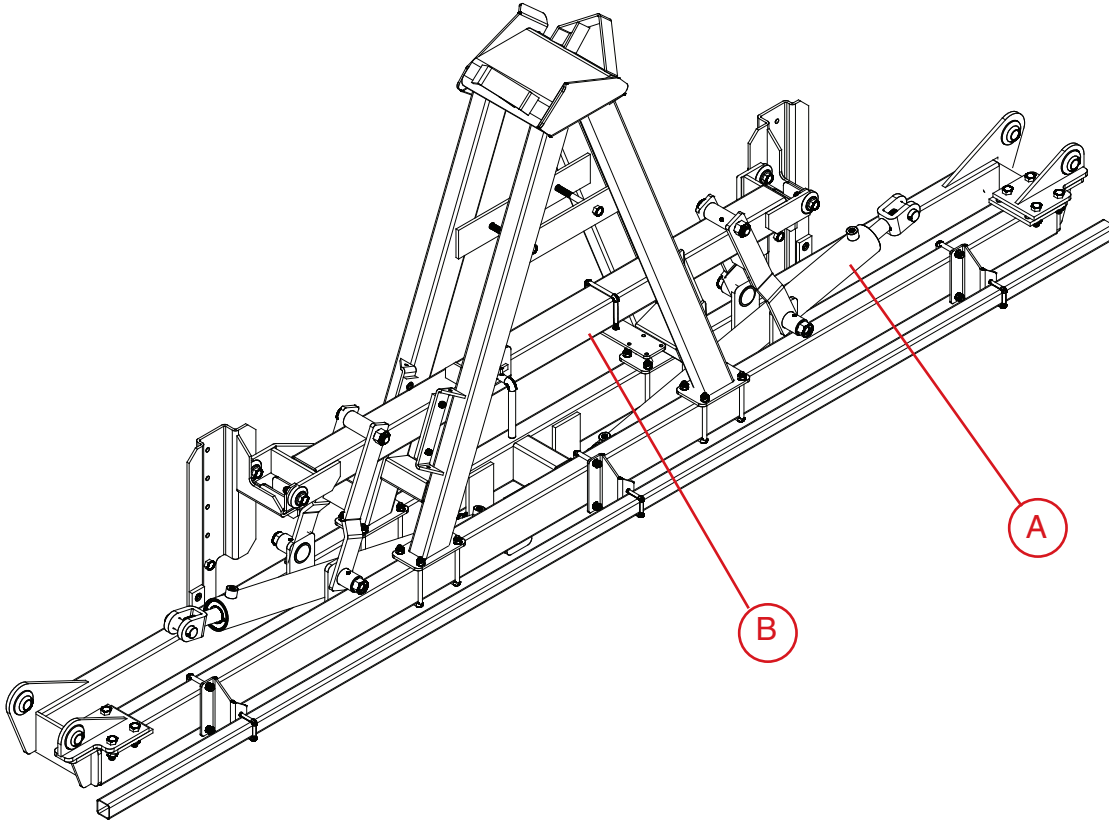

A. AB21009 Located on Wing Fold/Unfold Hydraulic Cylinder

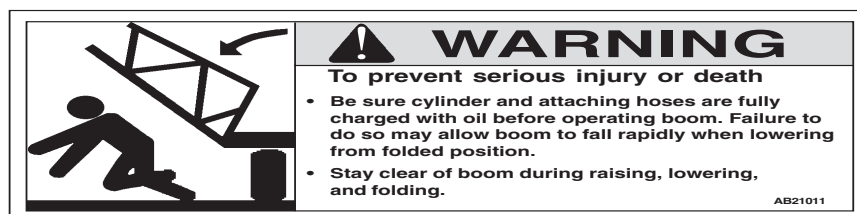

B. AB21011 Located on Auto-Level Mounting Tube Inside "A" Frame



BEFORE OPERATION:

- Carefully study and understand this manual.
- Do not wear loose-fitting clothing which may catch in moving parts.
- Always wear protective clothing and substantial shoes.
- It is recommended that suitable protective hearing and eye protection be worn.
- The operator may come in contact with certain materials which may require specific safety equipment relative to the handling of such materials. (Examples: extremely dusty, molds, fungus, bulk fertilizers, etc.)
- Keep wheel and lug nuts tightened to specified torque.
- Assure that agricultural implement tires are inflated evenly.
- Give the unit a visual inspection for any loose bolts, worn parts, or cracked welds, and make necessary repairs. Follow the maintenance safety instructions included in this manual.
- Be sure there are no tools lying on or in the equipment
- Do not use the unit until you are sure that the area is clear, especially around children and animals.
- Don't hurry the learning process or take the unit for granted. Ease into it and become familiar with your new equipment.
- Practice operation of your equipment and it's attachments. Completely familiarize yourself and other operators with it's operation before using.
- Make sure that the brakes are evenly adjusted (if equipped with brakes)
- Use a tractor equipped with Roll Over Protection System (ROPS) and fasten your seat belt prior to starting the engine.
- The manufacturer does not recommend usage of a tractor with the ROPS removed.
- Move the tractor wheels to the widest recommended settings to increase stability.
- Securely attach to towing unit. Use a high strength, appropriately sized hitch pin with a mechanical retainer and attach a safety chain.
- Do not allow anyone to stand between the tongue or hitch and the towing vehicle when backing up to the equipment.



DURING OPERATION

- **SAFETY CHAIN** - If equipment is going to be transported on a public highway, a safety chain should be obtained and installed. Always follow state and local regulations regarding safety chain and auxiliary lighting when towing farm equipment on a public highway. Be sure to check with local law enforcement agencies for your own particular regulations. Only a safety chain (not an elastic or nylon/plastic tow strap) should be used to retain the connection between the towing and towed machines in the event of separation of the primary attaching system.

- Install the safety chain by crossing the chains under the tongue and secure to the draw bar cage, hitch, or bumper frame.
- Beware of bystanders, **PARTICULARLY CHILDREN!** Always look around to make sure that it is safe to start the engine of the towing vehicle or move the unit. This is particularly important with higher noise levels and quiet cabs, as you may not hear people shouting.
- **NO PASSENGERS ALLOWED-** Do not carry passengers anywhere on or in the tractor or equipment.
- Keep hands and clothing clear of moving parts.
- Do not clean, lubricate, or adjust your equipment while it is moving.
- When halting operation, even periodically, set the tractor or towing vehicle brakes, disengage the PTO, shut off the engine, and **remove the ignition key.**
- Be especially observant of the operating area and terrain- watch for holes, rocks, or other hidden hazards. Always inspect the area prior to operation.
 - DO NOT operate near the edge of drop-offs or banks.
 - DO NOT operate on steep slopes as overturn may result.
 - Operate up and down (not across) intermediate slopes. Avoid sudden starts and stops.
- Pick the levellest possible route when transporting across fields. Avoid the edges of ditches, gullies, and steep hillsides.
- Be extra careful when working on inclines.
- Periodically clear the equipment of brush, twigs, or other materials to prevent buildup of dry combustible materials.
- Maneuver the tractor or towing vehicle at safe speeds.
- Avoid overhead wires or other obstacles. Contact with overhead lines could cause serious injury or death.
- Avoid loose fill, rocks, and holes; they can be dangerous for equipment operation or movement.
- Allow for unit length when making turns.
- Do not walk or work under raised components or attachments unless securely positioned and blocked.
- Keep all bystanders, pets, and livestock clear of the work area.
- Operate the towing vehicle from the operators seat only.
- Never stand alongside of unit with engine running or attempt to start engine and/or operate machine while standing alongside of unit.
- Never leave running equipment attachments unattended.
- As a precaution, always recheck the hardware on equipment following every 100 hours of operation. Correct all problems. Follow the maintenance safety procedures.



FOLLOWING OPERATION

- Following operation, or when unhitching, stop the tractor or towing vehicle, set the brakes, disengage the PTO and all power drives, shut off the engine and **remove the ignition keys**.
- Store the unit in an area away from human activity.
- Do not park equipment where it will be exposed to livestock for long periods of time. Damage and livestock injury could result.
- Do not permit children to play on or around the stored unit.
- Make sure all parked machines are on a hard, level surface and engage all safety devices.
- Wheel chocks may be needed to prevent unit from rolling.



HIGHWAY AND TRANSPORT OPERATIONS

- Adopt safe driving practices:
 - Keep the brake pedals latched together at all times. **NEVER USE INDEPENDENT BRAKING WITH MACHINE IN TOW, LOSS OF CONTROL AND/OR UPSET OF UNIT CAN RESULT.**
 - Always drive at a safe speed relative to local conditions and ensure that your speed is low enough for an emergency stop to be safe and secure. Keep speed to a minimum.
 - Reduce speed prior to turns to avoid the risk of overturning.
 - Always keep the tractor or towing vehicle in gear to provide engine braking when going downhill. Do not coast.
 - Do not drink and drive!
- Comply with state and local laws governing highway safety and movement of farm machinery on public roads.
- Use approved accessory lighting flags and necessary warning devices to protect operators of other vehicles on the highway during daylight and nighttime transport. Various safety lights and devices are available from your dealer.
- The use of flashing amber lights is acceptable in most localities. However, some localities prohibit their use. Local laws should be checked for all highway lighting and marking requirements.
- When driving the tractor and equipment on the road under 20 mph (40 kph) at night or during the day, use flashing amber warning lights and a slow moving vehicle (SMV) identification emblem.
- Plan your route to avoid heavy traffic.
- Be a safe and courteous driver. Always yield to oncoming traffic in all situations, including narrow bridges, intersections, etc.
- Be observant of bridge loading ratings. Do not cross bridges rated lower than the gross weight at which you are operating.

- Watch for obstructions overhead and to the side while transporting.
- Always operate equipment in a position to provide maximum visibility at all times. Make allowances for increased length and weight of the equipment when making turns, stopping the unit, etc.



PERFORMING MAINTENANCE

- Good maintenance is your responsibility. Poor maintenance is an invitation to trouble.
- Make sure there is plenty of ventilation. Never operate the engine of the towing vehicle in a closed building. The exhaust fumes may cause asphyxiation.
- Before working on this machine, stop the towing vehicle, set the brakes, disengage the PTO and all power drives, shut off the engine and **remove the ignition keys**.
- Be certain all moving parts and attachments have come to a complete stop before attempting to perform maintenance.
- **Always** use a safety support and block wheels. Never use a jack to support the machine.
- Always use the proper tools or equipment for the job at hand.
- Use extreme caution when making adjustments.
- Follow the torque chart in this manual when tightening bolts and nuts.
- Never use your hands to locate a hydraulic leak on attachments. Use a small piece of cardboard or wood. Hydraulic fluid escaping under pressure can penetrate the skin.
- When disconnecting hydraulic lines, shut off hydraulic supply and relieve all hydraulic pressure.
- Openings in the skin and minor cuts are susceptible to infection from hydraulic fluid. **Without immediate medical treatment, serious infection and reactions can occur.**
- Replace **all shields** and guards after servicing and before moving.
- After servicing, be sure all tools, parts and service equipment are removed.
- Do not allow grease or oil to build up on any step or platform.
- Never replace hex bolts with less than grade five bolts unless otherwise specified.
- Refer to bolt torque chart for head identification marking.
- Where replacement parts are necessary for periodic maintenance and servicing, genuine factory replacement parts must be used to restore your equipment to original specifications. The Manufacturer will not claim responsibility for use of unapproved parts and/or accessories and other damages as a result of their use.
- If equipment has been altered in any way from original design, the manufacturer does not accept any liability for injury or warranty.
- A fire extinguisher and first aid kit should be kept readily accessible while performing maintenance on this equipment.

BOLT TORQUE

TORQUE DATA FOR STANDARD NUTS, BOLTS, AND CAPSCREWS.

Tighten all bolts to torques specified in chart unless otherwise noted. Check tightness of bolts periodically, using bolt chart as guide. Replace hardware with same grade bolt.

NOTE: Unless otherwise specified, high-strength Grade 5 hex bolts are used throughout assembly of equipment.

Bolt Torque for Standard bolts *



Torque Specifications

"A"	GRADE 2		GRADE 5		GRADE 8	
	lb-ft	(N.m)	lb-ft	(N.m)	lb-ft	(N.m)
1/4"	6	(8)	9	(12)	12	(16)
5/16"	10	(13)	18	(25)	25	(35)
3/8"	20	(27)	30	(40)	45	(60)
7/16"	30	(40)	50	(70)	80	(110)
1/2"	45	(60)	75	(100)	115	(155)
9/16"	70	(95)	115	(155)	165	(220)
5/8"	95	(130)	150	(200)	225	(300)
3/4"	165	(225)	290	(390)	400	(540)
7/8"	170	(230)	420	(570)	650	(880)
1"	225	(300)	630	(850)	970	(1310)

Bolt Torque for Metric bolts *

"A"	CLASS 8.8		CLASS 9.8		CLASS 10.9	
	lb-ft	(N.m)	lb-ft	(N.m)	lb-ft	(N.m)
6	9	(13)	10	(14)	13	(17)
7	15	(21)	18	(24)	21	(29)
8	23	(31)	25	(34)	31	(42)
10	45	(61)	50	(68)	61	(83)
12	78	(106)	88	(118)	106	(144)
14	125	(169)	140	(189)	170	(230)
16	194	(263)	216	(293)	263	(357)
18	268	(363)	--	--	364	(493)
20	378	(513)	--	--	515	(689)
22	516	(699)	--	--	702	(952)
24	654	(886)	--	--	890	(1206)

Torque figures indicated are valid for non-greased or non-oiled threads and heads unless otherwise specified. Therefore, do not grease or oil bolts or capscrews unless otherwise specified in this manual. When using locking elements, increase torque values by 5%.

* GRADE or CLASS value for bolts and capscrews are identified by their head markings.

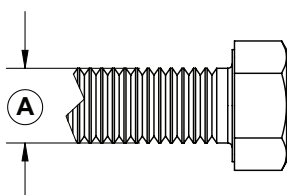

GRADE-2

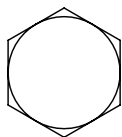

GRADE-5

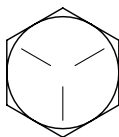

GRADE-8

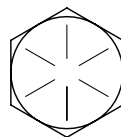

CLASS 8.8

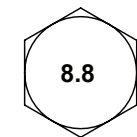

CLASS 9.8

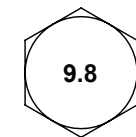

CLASS 10.9

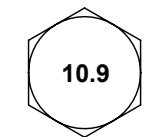

CENTER SECTION BREAKDOWN

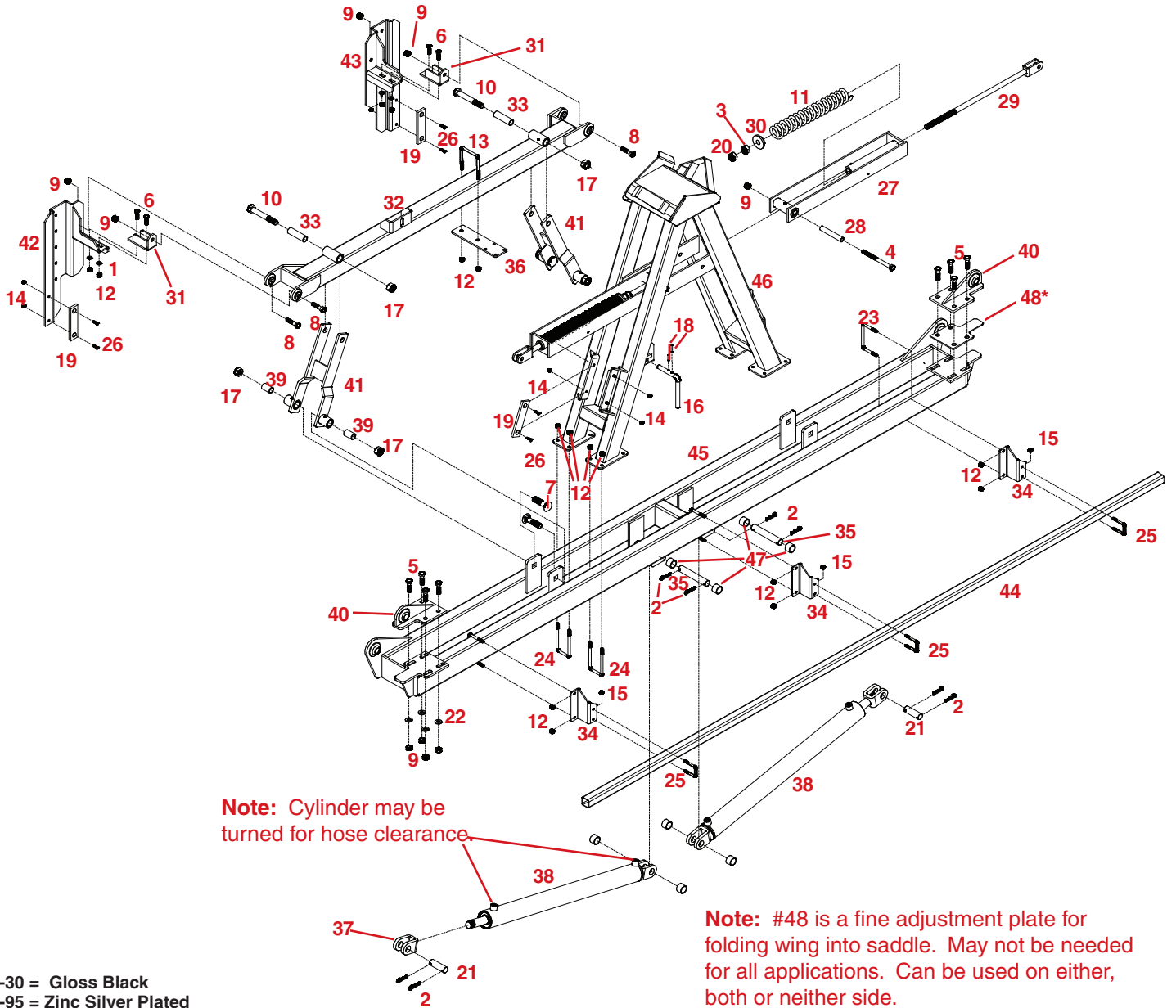

-30 = Gloss Black
-95 = Zinc Silver Plated

PARTS LIST

REF. NO.	PART NO.	QTY. REQD	DESCRIPTION
1.	00059	4	3/8" Flatwasher
2.	00116	8	Cotter Pin (5/32")
3.	00253	2	3/4"-10 UNC Hex Nut
4.	00349	2	1/2"-13 UNC x 6" Hex Head Bolt
5.	00482	8	1/2"-13 UNC x 1-3/4" Hex Head Bolt
6.	00523	4	3/8"-16 UNC x 1-1/4" Hex Head Bolt
7.	10675	4	3/4"-10 UNC x 3" Carriage Bolt
8.	01253	4	1/2"-13 UNC x 2" Hex Head Bolt
9.	02178	14	1/2"-13 UNC Nylon Insert Locknut
10.	02389	2	3/4"-10 UNC x 5" Hex Head Bolt
11.	02475-30	2	Compression Spring
12.	02592	28	3/8-16 UNC Nylon Insert Locknut
13.	02759	1	3/8"-16 UNC x 3" Square U-Bolt
14.	02772	12	1/4"-20 UNC Nylon Insert Locknut
15.	02802	6	5/16"-18 UNC Nylon Insert Locknut
16.	02951-95	1	Auto-Level Lock Pin
17.	02961	6	3/4"-10 UNC Nylon Insert Locknut
18.	03099	2	3/16" x 1" Roll Pin
19.	03324	6	Wear Strip
20.	03701	2	3/4"-10 UNC Hex Jam Nut
21.	03738-95	2	Upper Hydraulic Cylinder Pin (1" Dia. x 3" Long)
22.	04189	8	1/2" ID Machine Washer
23.	04494	3	3/8"-16 UNC x 3" x 4" Square U-Bolt
24.	05583	8	3/8"-16 UNC x 2-1/8" x 4-7/8" Square U-Bolt

REF. NO.	PART NO.	QTY. REQD	DESCRIPTION
25.	05678	3	5/16"-18 UNC x 1-1/2" x 2-1/4" Square U-Bolt
26.	05732	12	1/4"-20 UNC x 1" Slotted Flat Head Screw
27.	07566-30	2	Spring Housing
28.	07567-95	2	Spacer Bushing
29.	07568-30	2	Spring Shaft
30.	07569-95	2	Compression Spring Cap
31.	07573-30	2	Mounting Joint Bracket
32.	07574-30	1	Auto-Level Mounting Tube
33.	07575 -95	2	Upper Auto-Level Pivot Bushing
34.	07578-30	3	Center Tip Tube Mounting Plate
35.	07585-95	2	Lower Hydraulic Cylinder Pin (1" Dia. x 5-3/4" Long)
36.	09039-30	1	3-Way Valve Mounting Plate
37.	09741-30	2	Adjustable Cylinder Clevis End w/bolt
38.	10197-30	2	2-1/2" x 29-1/4" Hydraulic Cylinder (Clevis not included)
39.	10646-95	4	Lower Auto-Level Pivot Bushing
40.	10647-30	2	Adjustable Inner Joint Bracket
41.	10648-30	2	Auto-Level Swing Arms
42.	10649-30	1	Left Boom Mounting Bracket
43.	10650-30	1	Right Boom Mounting Bracket
44.	10652-30	1	Center Section Tip Mounting Tube
45.	10654-30	1	Boom Center Tube Assembly
46.	10655-30	1	Boom Rest "A" Frame
47.	10917-95	4	Lower Cylinder Pin Bushing
48.	10817-30	2	Fine adjustment shim plate

Please order replacement parts by **PART NO.** and **DESCRIPTION.**

CENTER SECTION ASSEMBLY INSTRUCTIONS

1. Support the Center Tube Assembly (#45) on two saw horses or other stable supports. Attach the Boom Rest "A" Frame (#46) using eight 3/8" Square U-Bolts (#24) and sixteen 3/8" Nylon Insert Locknuts (#12). The "A" Frame Assembly (#46) must be centered on Tube Assembly (#45).
2. Secure the Auto-Level Lock Pin (#16) to the "A" Frame Assembly (#46) using two 3/16" x 1 Roll Pins (#18). Stabilize the Auto-Level Mounting Tube (#32) by using the Lock Pin (#16).
3. Attach the Wear Strips (#19) to the "A" Frame Assembly using eight 1/4" x 1" Slotted Flat Head Screws (#26) and eight 1/4" Nylon Insert Locknuts (#14) (Do Not Over Tighten). Slide the Auto-Level Mounting Tube (#32) inside the "A" Frame Assembly (#46). The Mounting Tube (#32) must be tipped on its side during installation.
4. Attach the Swing Arms (#41) to the Tube Assembly (#45) using four Lower Pivot Bushings (#39), four 3/4" x 3" Carriage Bolts (#7) and four 3/4" Nylon Insert Locknuts (#17). Attach the Swing Arms (#41) to the Auto-Level Mounting Tube (#32) using two Upper Pivot Bushing (#33), two 3/4" x 5" Hex Head Bolts (#10) and two 3/4" Nylon Insert Locknuts (#17).
5. Slide the Compression Spring (#11) over the tubing on the Spring Housing (#27). Insert the Spring Shaft (#29) through the tubing on the Spring Housing and secure with one Compression Spring Cap (#30), one 3/4" Hex Nut (#3), and one 3/4" Jam Nut (#20). Repeat for other spring assembly. Tighten until 2" of thread is exposed.
6. Mount the spring assembly to the "A" Frame Assembly (#46) using one Spacer Bushing (#28), one 1/2" x 6" Hex Head Bolt (#4) and one 1/2" Nylon Insert Locknut (#9). Repeat for other spring assembly.
7. Attach the Wear Strips (#19) to the Left (#42) and Right (#43) Boom Mounting Brackets using four 1/4" x 1" Slotted Flat Head Screw (#26) and four 1/4" Nylon Insert Locknuts (#14). Mount the Joint Brackets (#31) to the Left (#42) and Right (#43) Boom Mounting Brackets using four 3/8" x 1-1/4" Hex Head Bolts (#6), four 3/8" Flatwashers (#1), and four 3/8" Nylon Insert Locknuts (#12). Do not tighten these bolts at this time.
8. Mount the Left and Right Boom Mounting Assemblies to the Auto-Level Mounting Tube (#32) using four 1/2" x 2" Hex Head Bolts (#8), and 1/2" Nylon Insert Locknuts (#9). Tighten the 3/8" bolts and nuts mounting the Joint Bracket at this time.
9. Mount the Adjustable Joint Bracket (#40) to Center Tube Assembly (#45) using eight 1/2" x 1-3/4" Hex Head Bolts (#5), eight 1/2" Machine washers (#22) and eight 1/2" Nylon Insert Locknuts (#9). Do not Tighten these bolts at this time.
10. Drain oil and install correct fittings in hydraulic cylinders and attach the Hydraulic Cylinders to the Center Tube Assembly (#45) using two Cylinder Pins (#35) and four Cotter Pins (#2).
11. Attach the Tip Tube Mounting Plates (#34) to the Center Tube Assembly (#45) using three 3/8" Square U-Bolts (#23) and six 3/8" Nylon Insert Locknuts (#12). Mount Tube Mounting Plate 12" from end. Mount the Tip Tube (#44) using three 5/16" Square U-Bolts (#25) and six 5/16" Nylon Insert Locknuts (#15).
12. **IF REQUIRED-** Attach 3-Way valve mounting plate (#36) to auto level mounting tube (#32) with 3/8" x 3" sq. U-bolt (#13). Attach 3-way control valve to plate (#36) with two 1/4" x 2" bolt, flat washer and lock nut (Valve stamped 2 should face the back of unit).

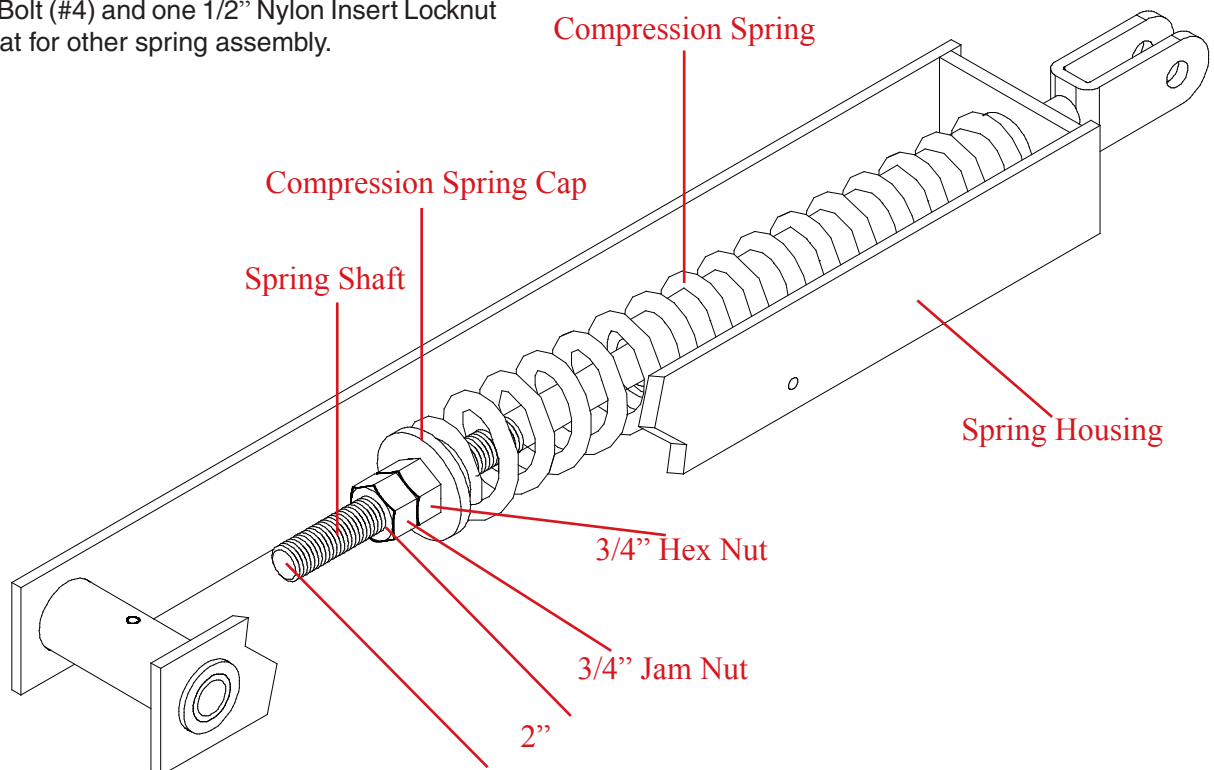

TRACTOR 3-POINT MOUNTING

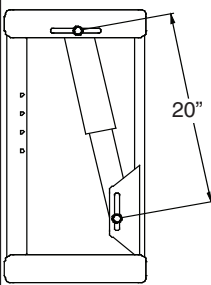
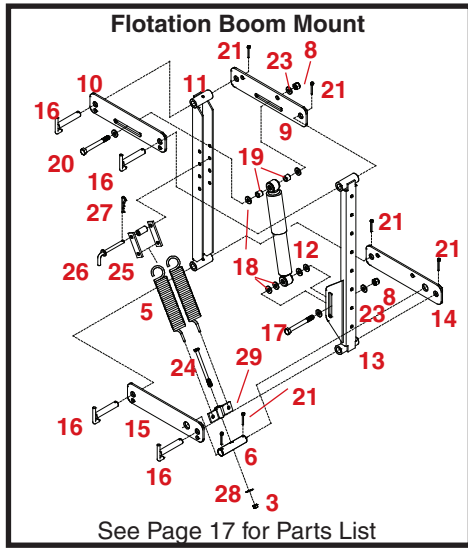
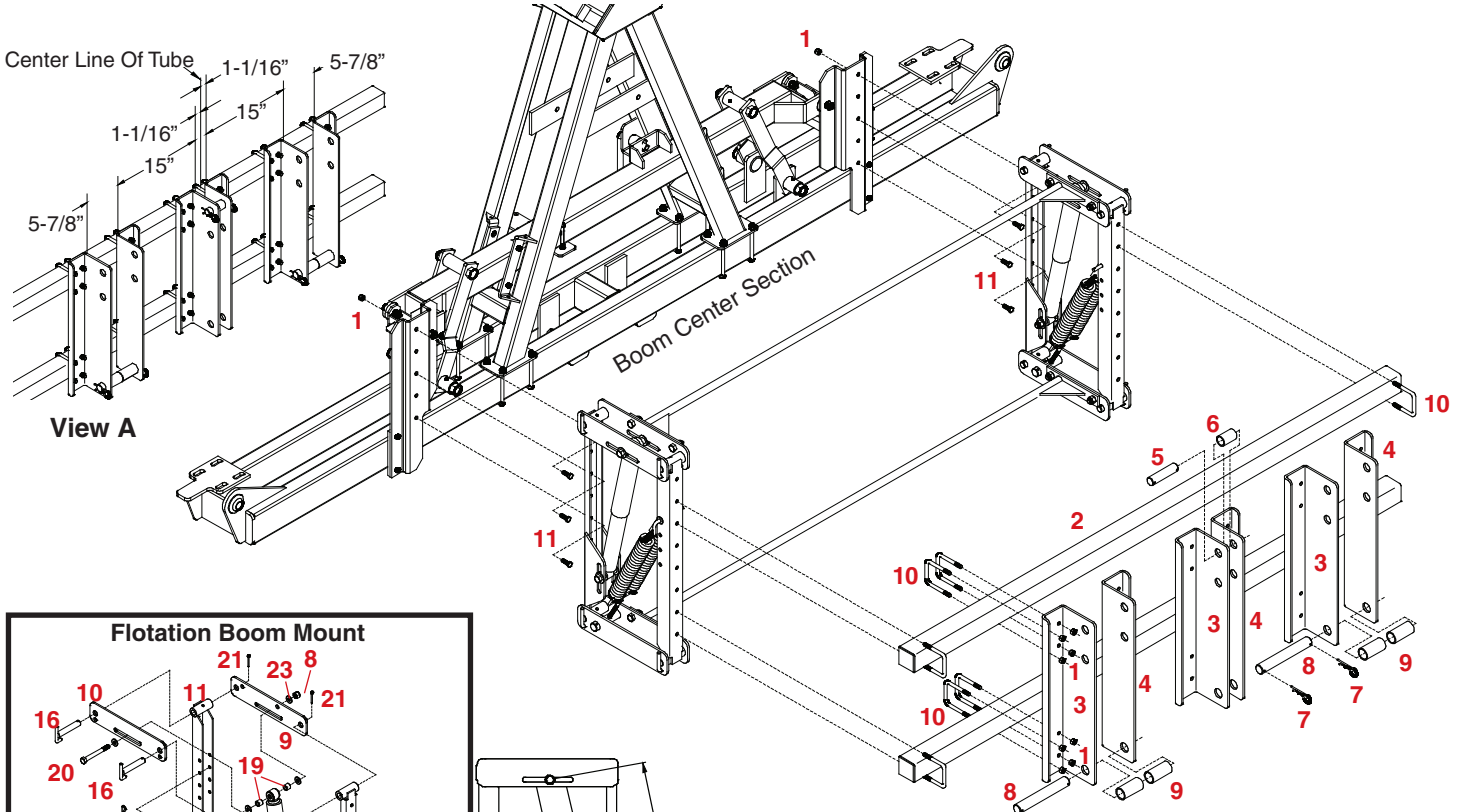

Please order replacement parts by
PART NO. and **DESCRIPTION**

3-POINT PARTS LIST

REF. NO.	PART NO.	QTY. REQD	DESCRIPTION
1.	02592	64	3/8" Nylon Insert Locknut
2.	09602-30	2	Boom Mounting Tube
3.	05676-30	3	Right Mounting Bracket
4.	05675-30	3	Left Mounting Bracket
5.	00332-95	1	1" dia. x 4" lg. Lift Pin
6.	05383-95	1	1-1/4" OD X 1" ID X 1-5/16"lg. bushing (Cat III only)
7.	11413	6	Hair Pin (#9)
8.	05382-95	2	1-1/8" dia. x 7-3/4" lg. Lift Pin
9.	00328-95	4	1-7/16" O.D x 1-3/16" I.D x 2-7/8" lg. Bushing
10.	01887	28	3/8" x 2-1/2" x 3-5/16" Square U-bolt
11.	00523	8	3/8"-16 UNC x 1-1/4" Hex Head Bolt

FLOTATION MOUNT INSTRUCTIONS

1. Begin by connecting the upper plate (#10) and upper torsion plate (#9) to the front carrier channel (#11) and the rear floating channel (#13) using the connecting pins (#16).
2. Use cotter pin (#21) to retain the connecting pins.
3. Bolt the shock absorber (#12) to the rear floating channel (#13) as shown using the 1/2" x 3-1/2" bolt (#17), six 1/2" flatwashers (#18) and 1/2" nylon insert locknuts (#8).
4. Fasten the shock absorber to the upper plates using the two shock spacers (#19), 1/2" x 4-1/2" bolt (#20), four 1/2" flatwashers (#18), and 1/2" hex locknut (#8).
5. Connect the lower plate (#15) and lower torsion plate (#14) to the front carrier channel (#11) and the rear channel (#13) using the connecting pins (#16). **NOTE: The lower plates are not both the same and must be installed as shown for left-hand assembly (opposite for right side).**
6. Slide the spring anchor pin (#6) through the hole in the lower plates (#14 & 15), using cotter pins (#21) to retain the spring anchor pin.
7. Connect mounting plates (#25) to the front carrier channel (#11) with pin (#26) and secure it with hair pin (#27).
8. Hook one end of the springs (#5) to the mounting plates (#25) and the other end through the tension bolt (#24) and insert it through the spring anchor pin (#6) and fasten with a 3/8" flatwasher and 3/8" locknut.

3-POINT ASSEMBLY INSTRUCTIONS

1. Assemble center section (page 6) before continuing. Then mount the assembled DBFT to the boom mounting brackets. Attach the boom carrier tubes (#2) with the 3/8" x 2-1/2" x 3-5/16" square U-bolts (#10) and 3/8" lock nuts (#1).
2. Fasten right and left lift brackets (#3) and (#4) to the boom carrier tubes (#2) with the 3/8" x 2-1/2" x 3-5/16" square U-bolts (#10) and 3/8" lock nuts (#1). **NOTE:** Position one set on each end and in the center of the boom mounting tubes (#2), do not tighten bolts at this time. See above **View A** for dimensions for mounting the brackets.
3. Connect the tractors center stabilizer arm to the center lift brackets by inserting lift pin (#5) through center lift bracket (#3), (Cat.II will require bushing (#6)), tractor center lift arm and center lift bracket (#4). Insert hair pin (#7) through both ends of lift pin (#5). Tighten all bolts for center lift brackets.
4. Adjust the outside lift arm brackets in or out to properly fit your tractor.
5. Connect tractor outside lift arms to the lift brackets by inserting lift pin (#8) through lift bracket (#3), bushing (#9), tractor lift arm and lift bracket (#4). Insert a hair pin (#7) through both ends of lift pin (#8). Tighten all bolts.

WING ASSEMBLY

ASSEMBLY

Center Section Assembly must be completed and secured to preferred vehicle before proceeding.

1. Attach the Inner Wing Assembly (#37) to the Adjustable Inner Joint Bracket and Center Section using a 7/8" x 9-1/2" Hex Head Bolt (#33) and 7/8" Locknut (#40). Position left wing assembly approximately 1" ahead of center and right wing assembly 1" behind center. Tighten bolts on inner joint bracket (final adjustment will need to be made when boom is folded).
2. String the Cable (#41) through the top tube of the Inner Wing (#37). Mount the Cable Sheave (#22) to the outer end of wing using a Stainless Steel Bushing (#26), 3/8" x 2-3/4" Hex Head Bolt (#11) and 3/8" Locknut (#14). **(Do Not Overtighten)**
3. Thread 1/2" jam nut (#7) onto 1/2" x 2" full thread bolt (#17) in end of inner wing (#37) (Final Adjustment To Be Made Later).
4. Mount the Outer Wing (#38) with the preassembled Breakaway (#31) to the Inner Wing (#37) using two 1/2" x 3" Carriage Bolts (#39) and 1/2" Locknuts (#12). Attach the Cable to the Breakaway Assembly using 1/2" x 1-1/2" Hex Head Bolt (#10) and 1/2" Locknut (#12). **(Do not overtighten)** Cable must be able to swivel).
7. Attach the Outer Wing Storage Bracket (#28) approximately 66" from outer end using two 1/4" x 2-1/4" Hex Head Bolts (#29) and 1/4" Locknuts (#16). Attach the Inner Wing Storage Bracket (#27) approximately 79" from outer hinge point using one 1/4" x 3/4 Hex Head Bolt (#8), one 1/4" Locknut (#16), two 5/16" Square U-Bolts (#21) and four 5/16" Locknuts (#43). These two storage brackets (#27 & #28) must fit together.
8. Install hydraulic hoses and fittings (see page 15). (Bleed air)
9. Extend the hydraulic cylinder to Inner Wing. Mount the Roller Brackets (#34) between Cylinder Clevis and Boom Lift Ear. Secure in place using Cylinder Pin (#21-Page 5) and Cotter

Pin (#2-Page 5)

10. Mount Cable Roller (#35) and Roller Bushing (#36) to Roller Brackets (#34) using one 7/16" x 1-3/4" Hex Head Bolt and one 7/16" Locknut. Be sure boom cable is guided through the bottom side of the roller (#35) before securing. **(Do Not Overtighten)**. Roller must be able to spin.
10. Secure other end of Cable (#41) to Spring Assembly on Center Section using a 1/2" x 2 Hex Head Bolt (#9) and 1/2" Locknut (#12).
11. Adjust the levelness of the outer wing by adjusting the 1/2" x 2 Full Threaded Hex Head Bolt (#17) and 1/2" Jam Nut (#7).
12. Fold wing into transport position loosen bolts on adjustable inner joint bracket for adjustment in storage bracket. Retighten bolts.
13. Install plastic caps (#18) in the ends of boom nozzle tubes. Repeat for opposite side.

Note: See Next page for Break Away Hinge Parts Identification

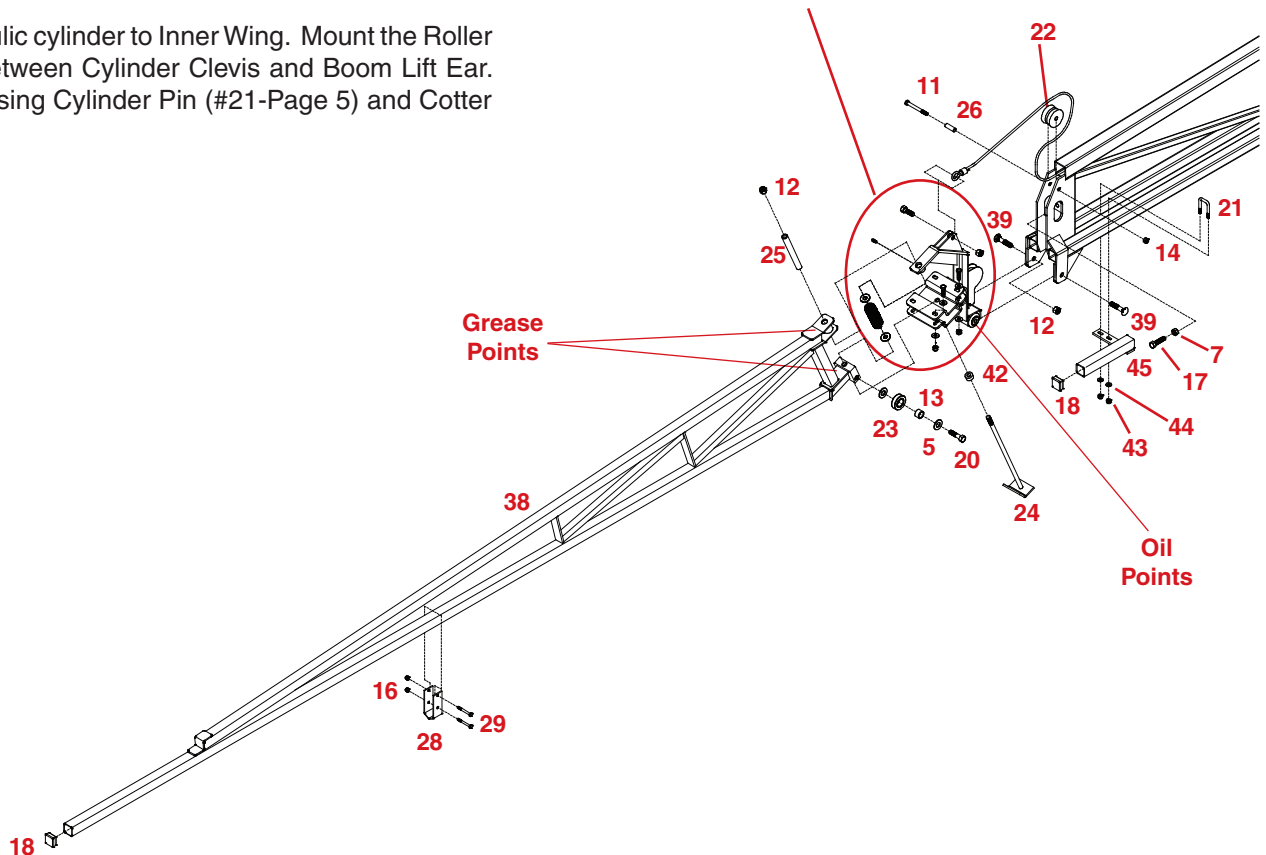

WING PARTS BREAKDOWN

BOOM WING PARTS LIST

REF. NO.	PART NO.	Qty. Reqd		DESCRIPTION
		60'	45'	
1.	00059	16	16	3/8" Flatwasher
2.	00085	4	4	1/2" Flatwasher
3.	00091	2	2	5/16"-18 UNC x 1/2" Square Head Set Screw
4.	00203	2	2	7/16"-14 UNC x 1-3/4" Hex Head Bolt
5.	00477	4	4	5/8" Flatwasher
6.	00523	8	8	3/8"-16 UNC x 1-1/4" Hex Bolt
7.	00640	2	2	1/2"-13 UNC Jam Nut
8.	01076	2	2	1/4"-20 UNC x 3/4" Hex Head Bolt
9.	01253	2	2	1/2"-13 UNC x 2" Hex Head Bolt
10.	01254	2	2	1/2"-13 UNC x 1-1/2" Hex Head Bolt

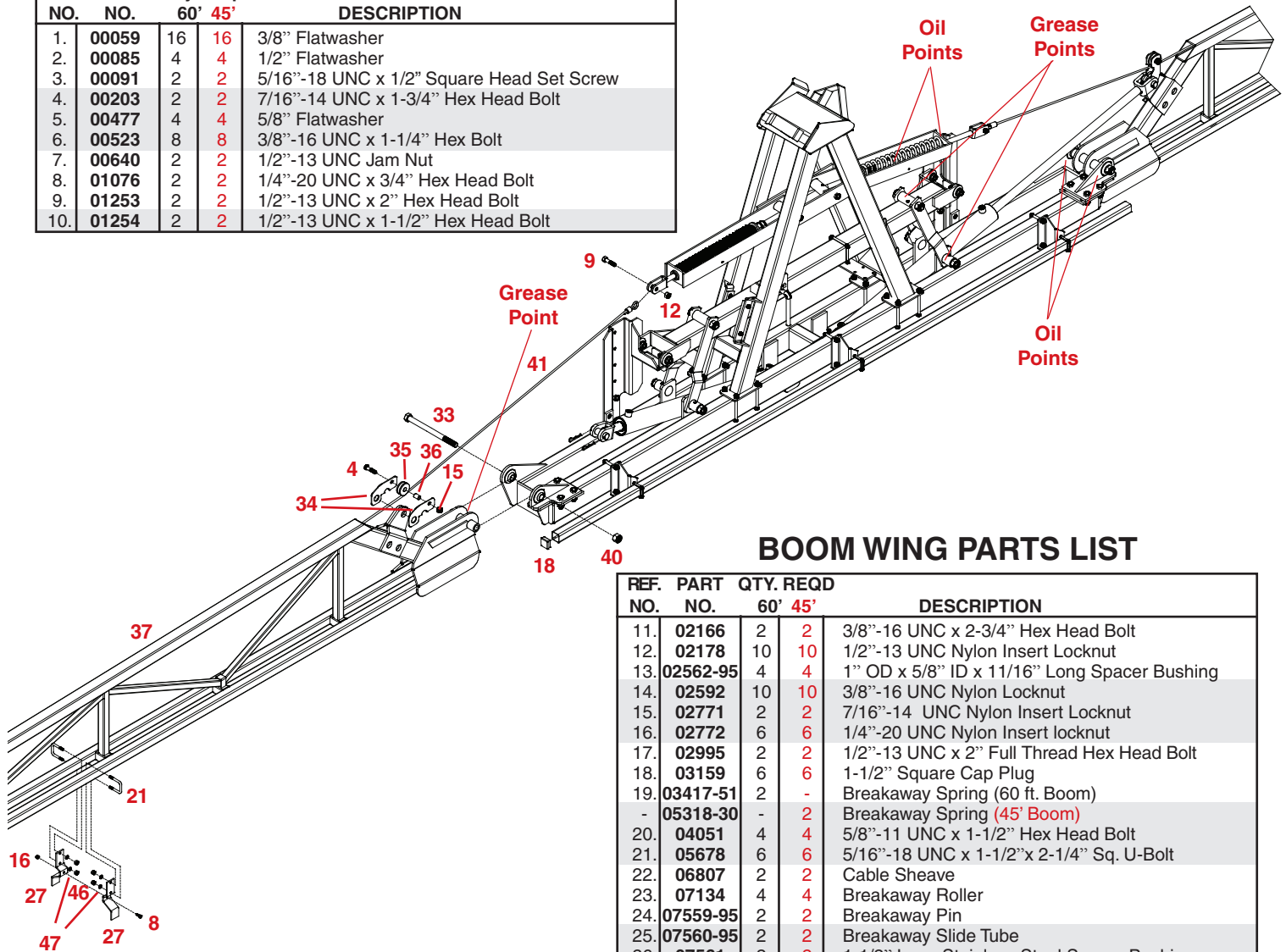

BOOM WING PARTS LIST

REF. NO.	PART NO.	QTY. REQD		DESCRIPTION
		60'	45'	
11.	02166	2	2	3/8"-16 UNC x 2-3/4" Hex Head Bolt
12.	02178	10	10	1/2"-13 UNC Nylon Insert Locknut
13.	02562-95	4	4	1" OD x 5/8" ID x 11/16" Long Spacer Bushing
14.	02592	10	10	3/8"-16 UNC Nylon Locknut
15.	02771	2	2	7/16"-14 UNC Nylon Insert Locknut
16.	02772	6	6	1/4"-20 UNC Nylon Insert locknut
17.	02995	2	2	1/2"-13 UNC x 2" Full Thread Hex Head Bolt
18.	03159	6	6	1-1/2" Square Cap Plug
19.	03417-51	-	-	Breakaway Spring (60 ft. Boom)
-	05318-30	-	-	Breakaway Spring (45' Boom)
20.	04051	4	4	5/8"-11 UNC x 1-1/2" Hex Head Bolt
21.	05678	6	6	5/16"-18 UNC x 1-1/2"x 2-1/4" Sq. U-Bolt
22.	06807	2	2	Cable Sheave
23.	07134	4	4	Breakaway Roller
24.	07559-95	2	2	Breakaway Pin
25.	07560-95	2	2	Breakaway Slide Tube
26.	07561	2	2	1-1/2" Long Stainless Steel Spacer Bushing
27.	07564-30	4	4	Inner Wing Boom Rest
28.	07565-30	2	2	Outer Wing Boom Rest
29.	07682	4	4	1/4"-20 UNC x 2-1/4" Hex Head Bolt
30.	07994-30	2	2	Breakaway Plate
31.	09336-30	2	2	Breakaway Hinge
33.	10645	2	2	7/8"-9 UNC x 9-1/2" Hex Head Bolt
34.	10651-30	4	4	Roller Mounting Bracket
35.	10653	2	2	Cable Roller
36.	10657	2	2	Roller Bushing 5/8" OD x 7/8" Long, SS
37.	10670-30	2	-	Inner Wing (60' ft. Boom)
-	10656-30	-	-	Inner Wing (45' Boom)
38.	10671-30	2	-	Outer Wing (60 ft. Boom)
-	09335-30	-	-	Outer Wing (45' Boom)
39.	10676	4	4	1/2"-13 UNC x 2-1/2" Carriage Bolt
40.	10678	2	2	7/8"-9 UNC Nylon Insert Locknut
41.	10685	2	-	187" Cable Assembly (60 ft. Boom)
-	09331	-	-	158-1/2" Cable Assembly (45' Boom)
42.	32CS	2	2	1" OD x 3/4" ID x 1-1/2" Long Spacer Bushing
43.	02802	12	12	5/16"-16 UNC Nylon Insert Locknut
44.	00004	4	4	5/16" Flatwasher
45.	07579-30	2	2	Offset Tip Bracket
46.	00007	8	8	5/16"-18 UNC Hex Nut
47.	00036	8	8	5/16" Lock Washer

BREAK AWAY HINGE

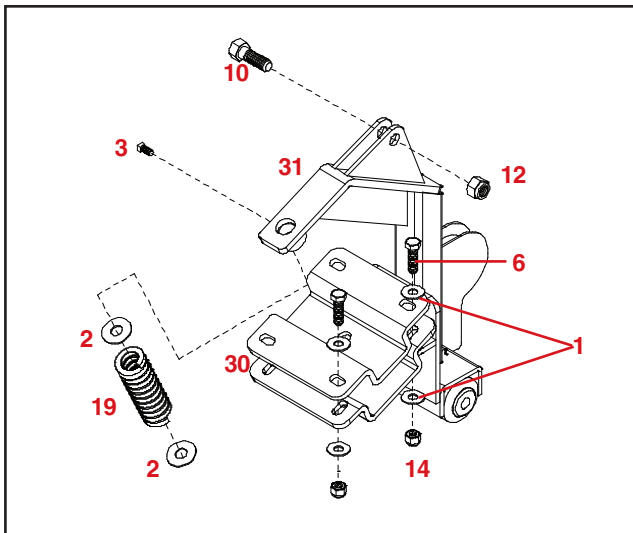

-30 = Gloss Black
 -95 = Zinc Silver Plated
 -51 = Pearl Gray

TRAILER, CONQUEST, & SIDEQUEST BOOM CARRIER ASSEMBLY

Standard sprayer frame, without Height Adjuster shown.

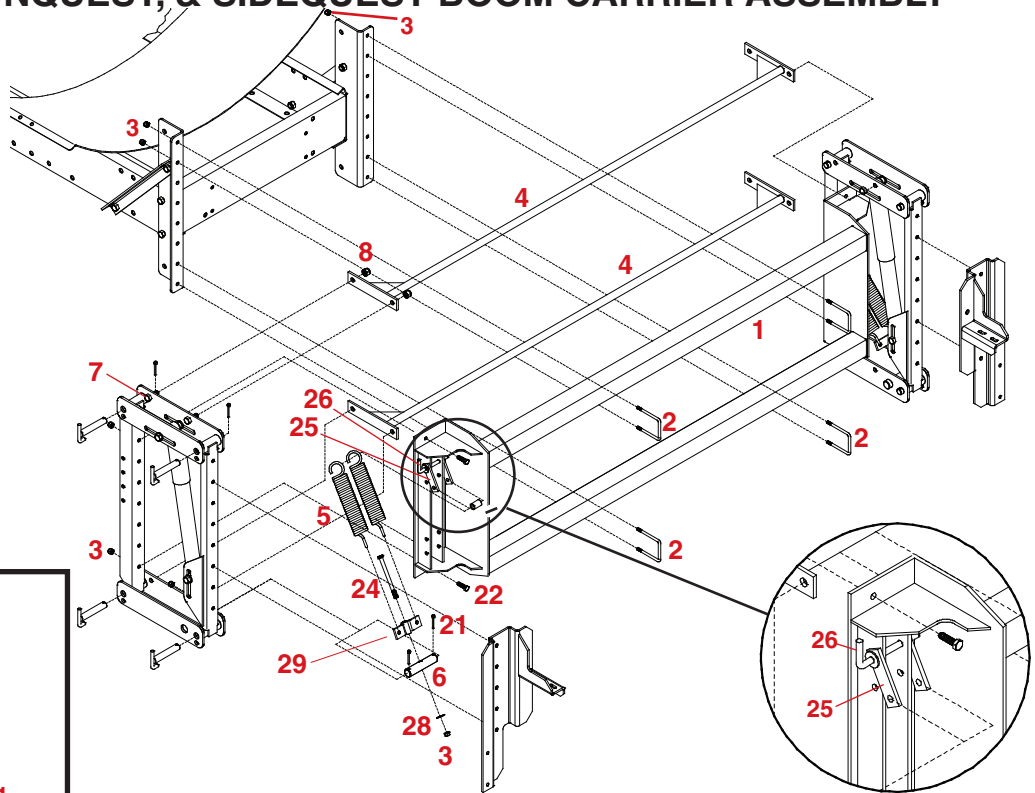
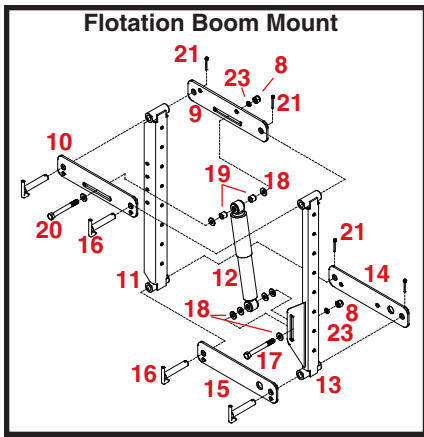
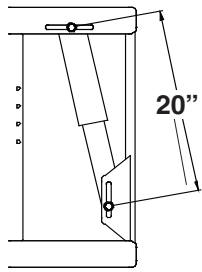

ASSEMBLY INSTRUCTIONS

1. Attach the Front Carrier Channel (#11) to each end of the Boom Carrier (#1), using eight 3/8" x 1-1/4" bolts (#22), eight 3/8" flat washers (#28) and eight 3/8" locknuts (#3). **Do Not Tighten.**
2. Begin by connecting the upper plate (#10) and upper torsion plate (#9) to the front carrier channel (#11) and the rear floating channel (#13) using the connecting pins (#16). Use cotter pin (#21) to retain the connecting pins.

NOTE: The upper plates are not both the same and must be installed as shown for left-hand assembly (opposite for right side).

3. Connect the lower plate (#15) and lower torsion plate (#14) to the front carrier channel (#11) and the rear channel (#13) using the connecting pins (#16). **NOTE: The lower plates are not both the same and must be installed as shown for left-hand assembly (opposite for right side).**
4. Slide the spring anchor pin (#6) through the hole in the lower plates (#14 & 15), using cotter pins (#21) to retain the spring anchor pin.
5. Hook one end of the springs (#5) to the mounting plates (#25) and the other end to the tension bolt plate (#29) using the tension bolt (#24) and insert it through the spring anchor pin (#6) and fasten with a 3/8" flatwasher and 3/8" locknut.
6. Connect spring mounting plates (#25) to the outside of front carrier channel (#11) with pin (#26) and secure it with hair pin.
7. Bolt the shock absorber (#12) to the rear floating channel (#13) as shown using the 1/2" x 3-1/2" bolt (#17), six 1/2" flatwashers (#18) and 1/2" nylon insert locknut (#8).
8. Fasten the shock absorber to the upper plates using the two shock spacers (#19), 1/2" x 4-1/2" bolt (#20), four 1/2" flatwashers (#18), and 1/2" hex locknut (#8).
9. Mount the Torsion Bars (#4) to the Flotation Boom Mounts on both sides, top and bottom using eight 1/2" x 1-1/4" (#7) bolts and eight 1/2" locknuts (#8) as shown.

10. Center flotation boom mount on boom carriers and tighten bolts.

PARTS LIST

REF. NO.	PART NO.	QTY. REQD	DESCRIPTION
1.	03844-?	1	Boom Carrier (?=10 Red, 20 Green)
2.	01887	4	3/8"-16 UNC x 2-1/2" U-bolt
3.	02592	12	3/8"-16 UNC Nylon Insert Locknut
4.	00201-30	2	Torsion Bars
5.	07838-51	4	Spring
6.	00198-95	2	Spring Anchor Pin
7.	00967	8	1/2"-13 UNC x 1-1/4" Hex Head Bolt (Gr 5)
8.	02178	12	1/2"-13 UNC Nylon Insert Locknut
9.	00187-30	2	Upper Parallel Torsion Plate
10.	00186-30	2	Upper Parallel Plate
11.	00188-30	2	Front Carrier Channel
12.	00192-30	2	Shock Absorber
13.	00189-30	2	Rear Floating Channel
14.	00197-30	2	Lower Parallel Torsion Plate
15.	00196-30	2	Lower Parallel Plate
16.	00190-95	8	Connecting Pin
17.	01897	2	1/2"-13 UNC x 3-1/2" Hex Head Bolt (Gr 5)
18.	00085	18	1/2" Flatwasher
19.	00193-95	4	Shock Spacers
20.	01338	2	1/2"-13 UNC x 4-1/2" Hex Head Bolt (Gr 5)
21.	00191	12	Cotter Pin
22.	00523	4	3/8"-16 UNC x 1-1/4" Hex Head Bolt (Gr 5)
23.	00084	4	1/2" Lockwasher
24.	00675	2	3/8"-16 UNC x 5" Hex Head Bolt (Gr.5)
25.	02967-95	4	Spring Mounting Plate
26.	00199-95	2	Pin
27.	00182	2	Small Hair Pin (not shown)
28.	00059	2	3/8" Flatwasher
29.	07836-95	2	Tension Bolt Plate

Please order replacement parts by PART NO. and DESCRIPTION.

REAR MOUNT MOUNTING PARTS BREAKDOWN

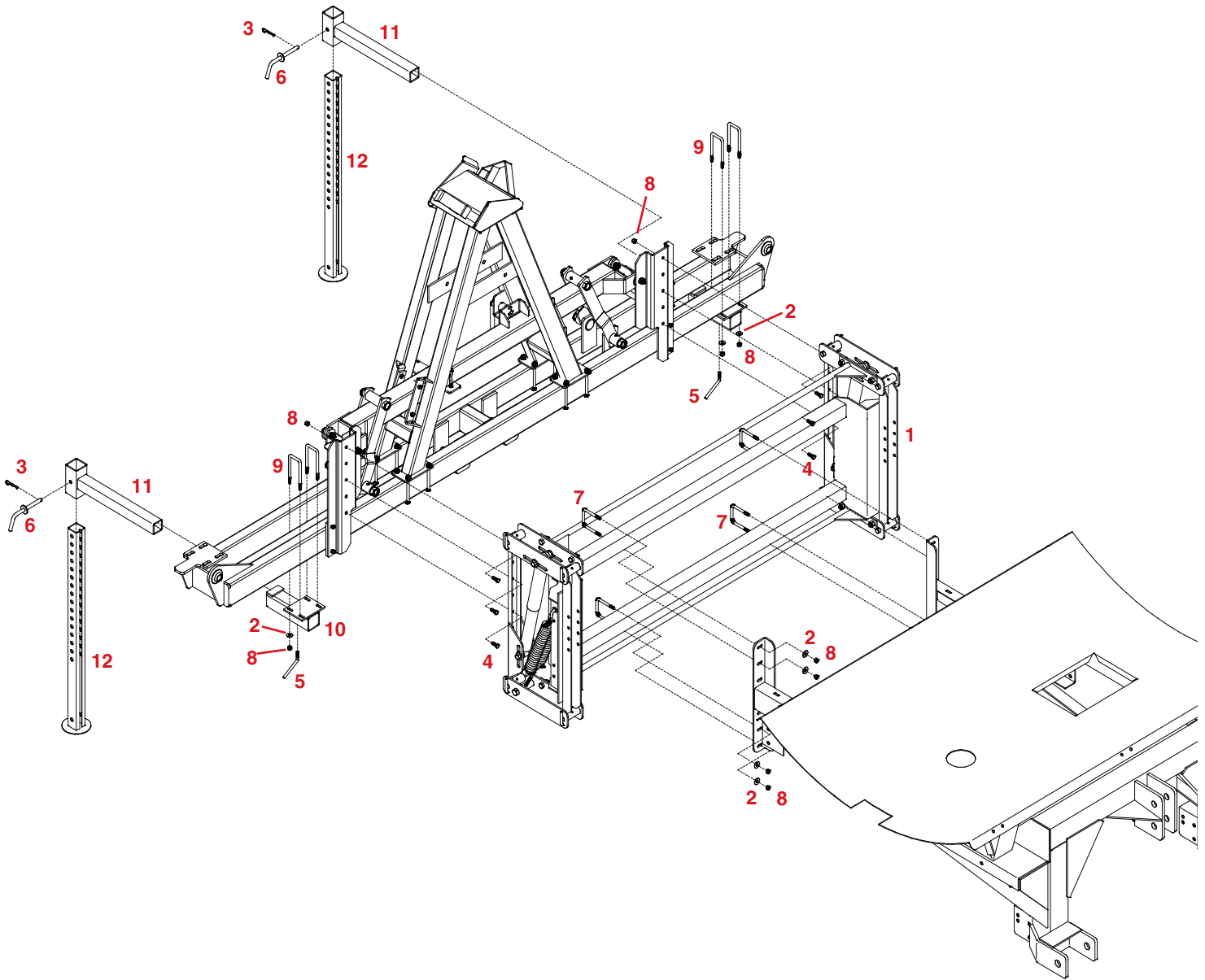

REAR MOUNT ASSEMBLY INSTRUCTIONS

1. Assemble the center section (page 6), Flotation boom mount (page 14), and the Rear Mount before continuing.
2. Mount the boom flotation/carrier assembly (#1) to the left and right boom mounting brackets with four 3/8" x 2-1/2" x 3-5/16" square U-bolts (#7), eight 3/8" flatwashers (#2) and eight 3/8" lock nuts (#8).
3. Mount the assembled boom center section to the assembled Boom Flotation Mount to the boom carrier tubes with eight 3/8" x 1-1/4" hex head bolts (#4) and eight 3/8" nylon insert locknuts (#8). **NOTE: The center section may need to be supported until the Safety Stands are mounted.**
4. Mount the safety stand assembly to the boom center section as shown.

REAR MOUNT PARTS LIST

REF. PART NO.	QTY. REQD	DESCRIPTION
1.	-	Boom Flotation/Carrier Assembly
2.	00059	16 3/8" Flatwasher
3.	00182	2 Hair Pin (#11)
4.	00523	8 3/8"-16 UNC x 1-1/4" Hex Head Bolt
5.	01404-95	2 Locking Handle
6.	01718-95	2 Lock Pin
7.	01887	4 3/8" x 2-1/2" x 3-5/16" Square U-bolt
8.	02592	24 3/8" Nylon Insert Locknut
9.	05583	4 3/8"-16 UNC x 2-1/8" x 4-7/8" Square U-Bolt
10.	07650-30	2 Receiver Tube
11.	07651-30	2 Rear Insert Tube
12.	07735-30	2 Adjustable Leg

Please order replacement parts by **PART NO.** and **DESCRIPTION**

GROUND STORAGE STAND FOR 3-POINT MOUNTING

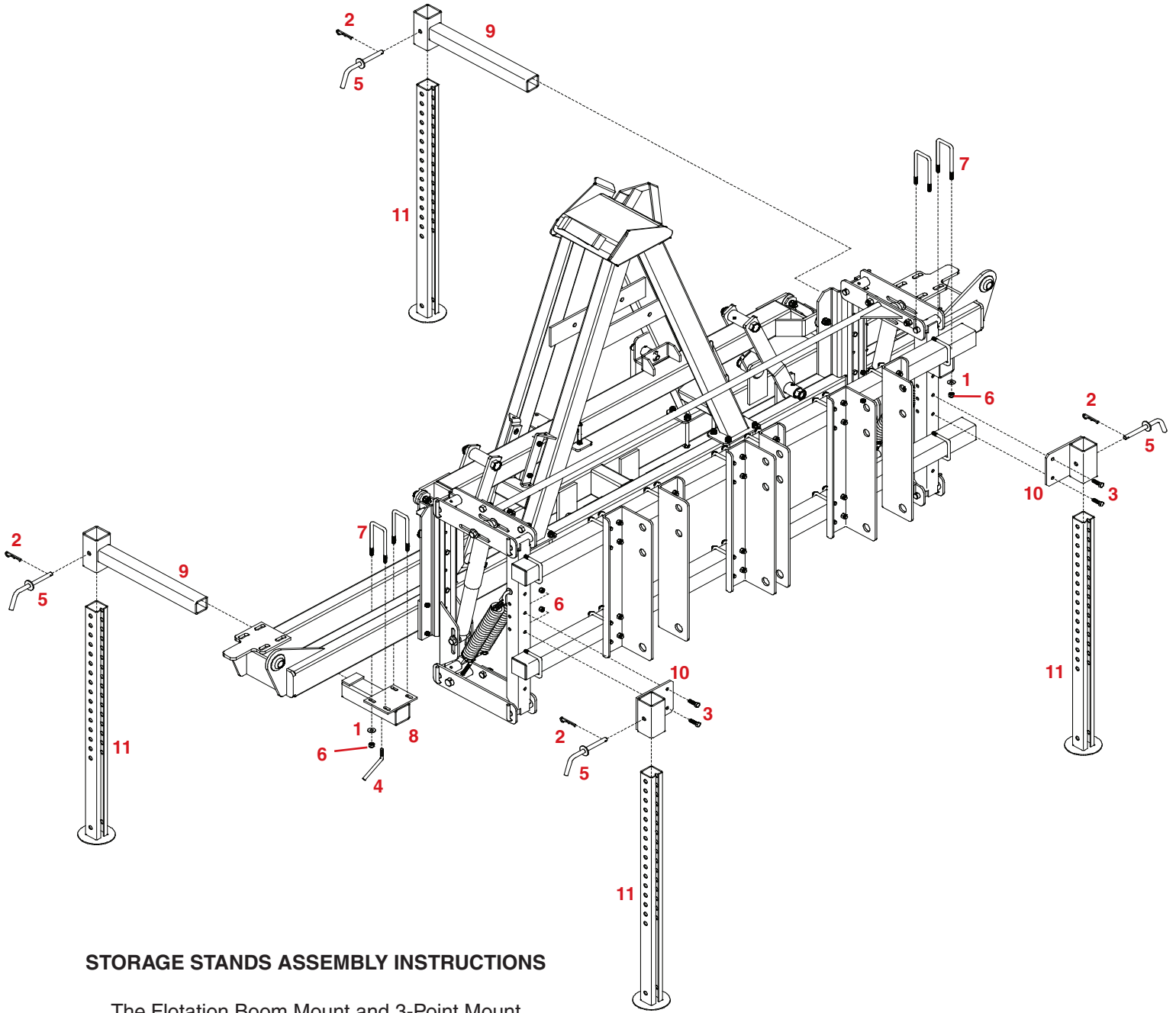

STORAGE STANDS ASSEMBLY INSTRUCTIONS

The Flotation Boom Mount and 3-Point Mount must be assembled before proceeding.

1. Mount the Rear Leg Receiver Tube (#8) to the bottom of the Center Tube Assembly using two 3/8" Square U-Bolts (#7), four 3/8" Flatwashers (#1) and four 3/8" Locknuts (#6).
2. Mount the Front Leg Receiver Tube (#10) to the DBFT Channels as shown. Note: These must be in the holes directly above the DTB3 mounting bolts. Use two 3/8" x 1-1/4" Hex Head Bolts (#3) and two 3/8" Locknuts (#6).
3. Insert the Rear Insert Tube (#9) and secure using a 3/8" Locking Bolt (#4)
4. Insert the Adjustable Legs (#11) and secure using a Locking Pin (#5) and Hair Pin (#2)

Repeat on other side.

3-POINT GROUND STORAGE PARTS LIST (9488011)

REF. NO.	PART NO.	QTY. REQD	DESCRIPTION
1.	00059	8	3/8" Flatwasher
2.	00182	4	Hair Pin (#11)
3.	00523	4	3/8"-16 UNC x 1-1/4" Hex Head Bolt
4.	01404-95	2	Locking Handle
5.	01718-95	4	Lock Pin
6.	02592	12	3/8"-16 UNC Nylon Insert Locknut
7.	05583	4	3/8"-16 UNC x 2-1/8" x 4-7/8" Square U-bolt
8.	07650-30	2	Rear Leg Receiver Tube
9.	07651-30	2	Rear Insert Tube
10.	07652-30	2	Front Leg Receiver Tube
11.	07735-30	4	Adjustable Leg

Please order replacement parts by PART NO. and DESCRIPTION.

AUTO-LEVEL SUPPORT BAR KIT

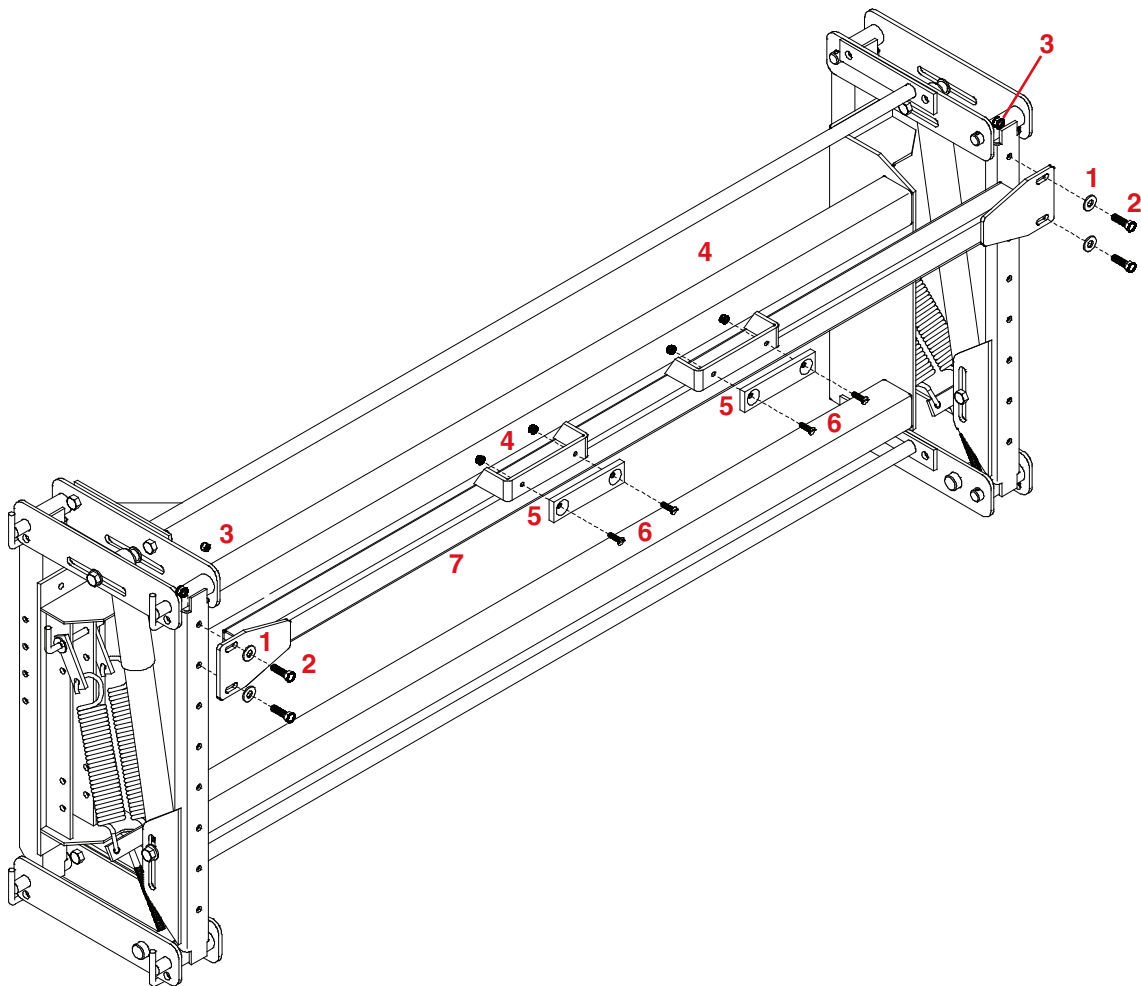

PARTS LIST

REF. NO.	PART NO.	QTY.	DESCRIPTION
1.	00059	4	3/8" Flatwasher
2.	00523	4	3/8"- UNC x 1 1/4 Hex Hd. Bolt Gr.5
3.	02592	4	3/8"- UNC Nylon Insert Locknut
4.	02772	4	1/4"- UNC Nylon Insert Locknut
5.	03324	2	Auto-level Wear Pad
6.	05732	4	1/4"- UNC x 1" Slotted Flat Hd. Bolt
7.	10025-30	1	Auto-level Support Bar

Please order replacement parts by **PART NO.** and **DESCRIPTION**

Instructions:

1. Mount the Auto-level Support Bar to the DBFT using the top two holes in the uprights as shown. Use four 3/8" bolts, four 3/8" flatwashers, and four 3/8" nylon insert nuts to attach it to the DBFT as shown. Make sure Auto-level Support Bar is positioned as shown, with the brackets on the bar facing up and to the back.

2. Attach the Auto-level Wear Pads to the Auto-level Support Bar. Use four 1/4" slotted flat head bolts and four 1/4" nylon insert locknuts. Attach the Auto-level Wear Pads as shown.

MOUNTING THE DBFT BOOM CARRIER WITH HYDRAULIC HEIGHT ADJUST

CAUTION: Do not operate height adjust until final adjustments have been made. Never stand on or near the boom during height adjust operation.

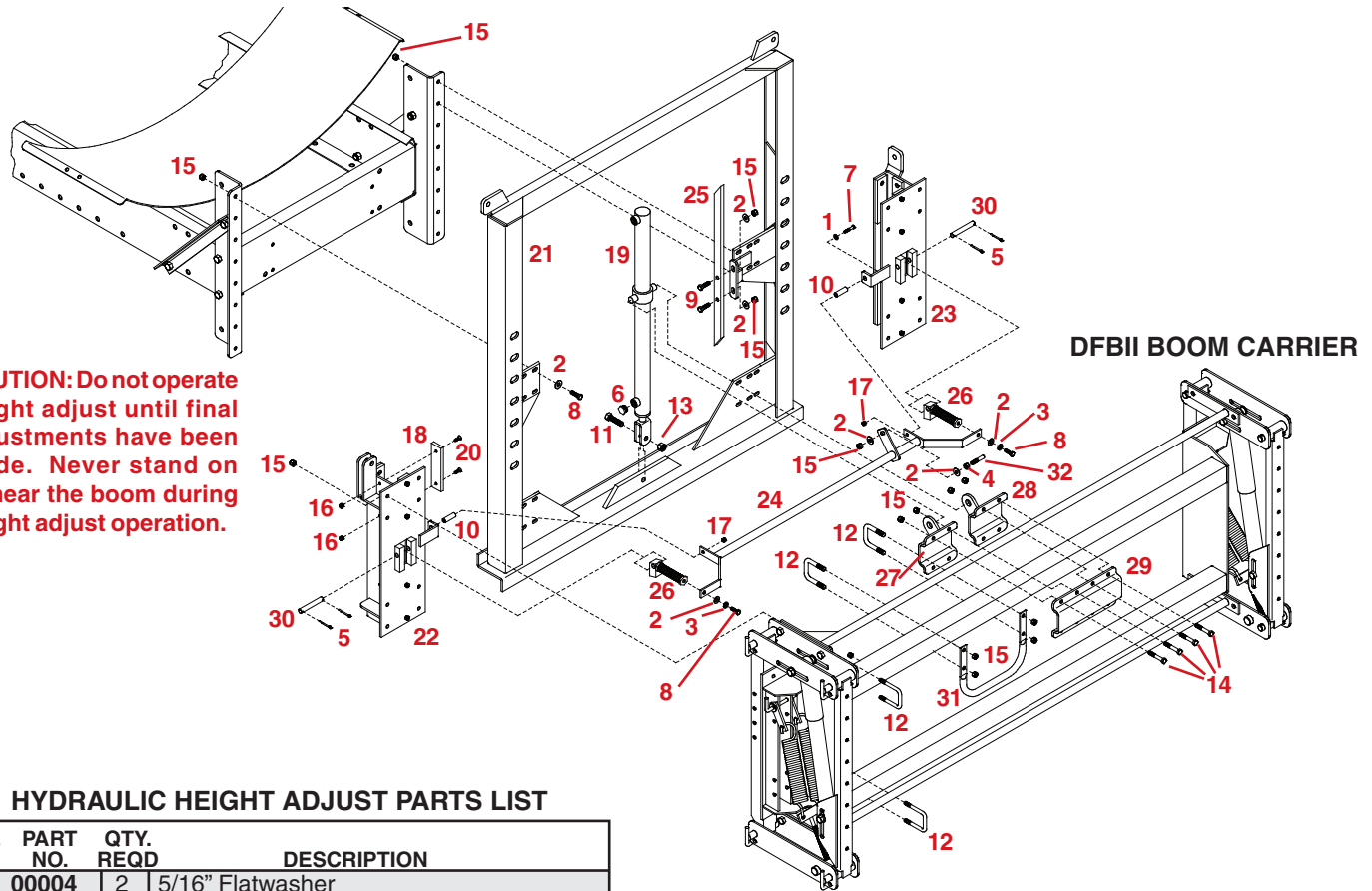

HYDRAULIC HEIGHT ADJUST PARTS LIST

REF. NO.	PART NO.	QTY. REQD	DESCRIPTION
1.	00004	2	5/16" Flatwasher
2.	00059	12	3/8" Flatwasher
3.	00060	2	3/8" Lock Washer
4.	00061	1	3/8"-16 UNC Hex Nut
5.	00185	4	Cotter Pin
6.	00288	1	Air Vent - Hydraulic Cylinder
7.	00372	2	5/16"-18 UNC x 1-1/2" Hex Head Bolt
8.	00523	10	3/8"-16 UNC x 1-1/4" Hex Head Bolt
9.	00914	2	3/8"-16 UNC x 1-1/2" Hex Head Bolt
10.	01212-95	2	Bushing 1/2" O.D. x 5/16" I.D. x 5/8" Lg.
11.	01253	1	1/2"-13 UNC x 2" Hex Head Bolt
12.	01887	6	3/8"-16 UNC x 2-1/2" Sq. U-bolt
13.	02178	1	1/2"-13 UNC Nylon Insert Locknut
14.	02494	8	3/8"-16 UNC x 2-1/4" Hex Head Bolt
15.	02592	31	3/8"-16 UNC Nylon Insert Locknut
16.	02772	24	1/4"-20 UNC Nylon Insert Locknut
17.	02802	2	5/16"-18 UNC Nylon Insert Locknut
18.	03324	12	UHMW Strip
19.	05600-30	1	Cylinder
20.	05732	24	1/4"-20 UNC x 1" Slotted Flat Head Screw
21.	07841-30	1	Frame
22.	07842-30	1	Left Slide Bracket
23.	07843-30	1	Right Slide Bracket
24.	07844-30	1	Latch Actuator
25.	07845-30	1	Slide Bar
26.	07846-30	2	Latch Assembly
27.	07848-30	1	Left Cylinder Mount
28.	07849-30	1	Right Cylinder Mount
29.	07850-30	1	Cylinder Mount Backup Plate
30.	07851-95	2	Latch Pin
31.	07852-30	1	Hose Keeper
32.	07854-95	1	Slide Guide Stud
-	5222	-	Cylinder Repair Kit

Please order replacement parts by **PART NO.** and **DESCRIPTION.**

ASSEMBLY INSTRUCTIONS

- Mount the height adjust frame (#21) to the boom mounting brackets on sprayer frame (not shown) using eight 3/8" x 1-1/4" bolts, eight 3/8" flatwashers, and eight 3/8" locknuts.
- Attach twelve UHMW plastic strips (#18) to the left and right slide brackets (#22 & #23) using twenty-four 1/4" x 1" slotted head screws (#20), and twenty-four 1/4" locknuts (#16). **Do Not Overtighten.**
- Install both latches (#26) onto slider brackets using pins (#30), and four cotter pins (#5). Slide left and right slider brackets (#22 & #23) onto the mainframe (#21). Slide each slider bracket up until latches fall into first slot (be sure both latches are in the same slot on each upright). C-clamp into position.
- Attach the latch actuator (#24) to the slider brackets using two 5/16" x 1-1/2" bolts (#7), two bushings (#10), two 5/16" flatwashers (#1), and two 5/16" locknuts (#17). Attach DFBII boom carrier to the slider brackets using eight 3/8" x 2-1/2" Sq. U-bolts (#12), and sixteen 3/8" locknuts (#15).
- Attach latch actuator (#24) to latches using two 3/8" x 1-1/4" bolts (#8), two lock washers (#3) and two 3/8" flatwashers (#2). Mount slide bar (#25), in high position, to frame (#21) using two 3/8" x 1-1/2" bolts (#9), two 3/8" flatwashers (#2), and two 3/8" locknuts (#15). Install slide guide stud (#32) to latch actuator (#24) using two flatwashers (#2), one 3/8" hex nut (#4), and one 3/8" locknut (#15) to back of slot. Mount the hose keeper (#31) to the upper tube of the DFBII boom carrier using two 3/8" x 2-1/2" Sq. U-bolts (#12), and four 3/8" locknuts (#15).
- Mount cylinder (#19) to the frame (#21) using 1/2" x 2" bolt (#11), and 1/2" locknut (#13). Attach cylinder to the DFBII boom carrier using left and right cylinder mounts (#27 & #28), and cylinder mount backup plate (#29), eight 3/8" x 2-1/4" bolts (#14), and eight 3/8" locknuts (#15). Mounts should be centered.
- Install air vent (#6) to bottom of cylinder with hole down to keep water out.

2 CYLINDER HYDRAULICS BREAKDOWN

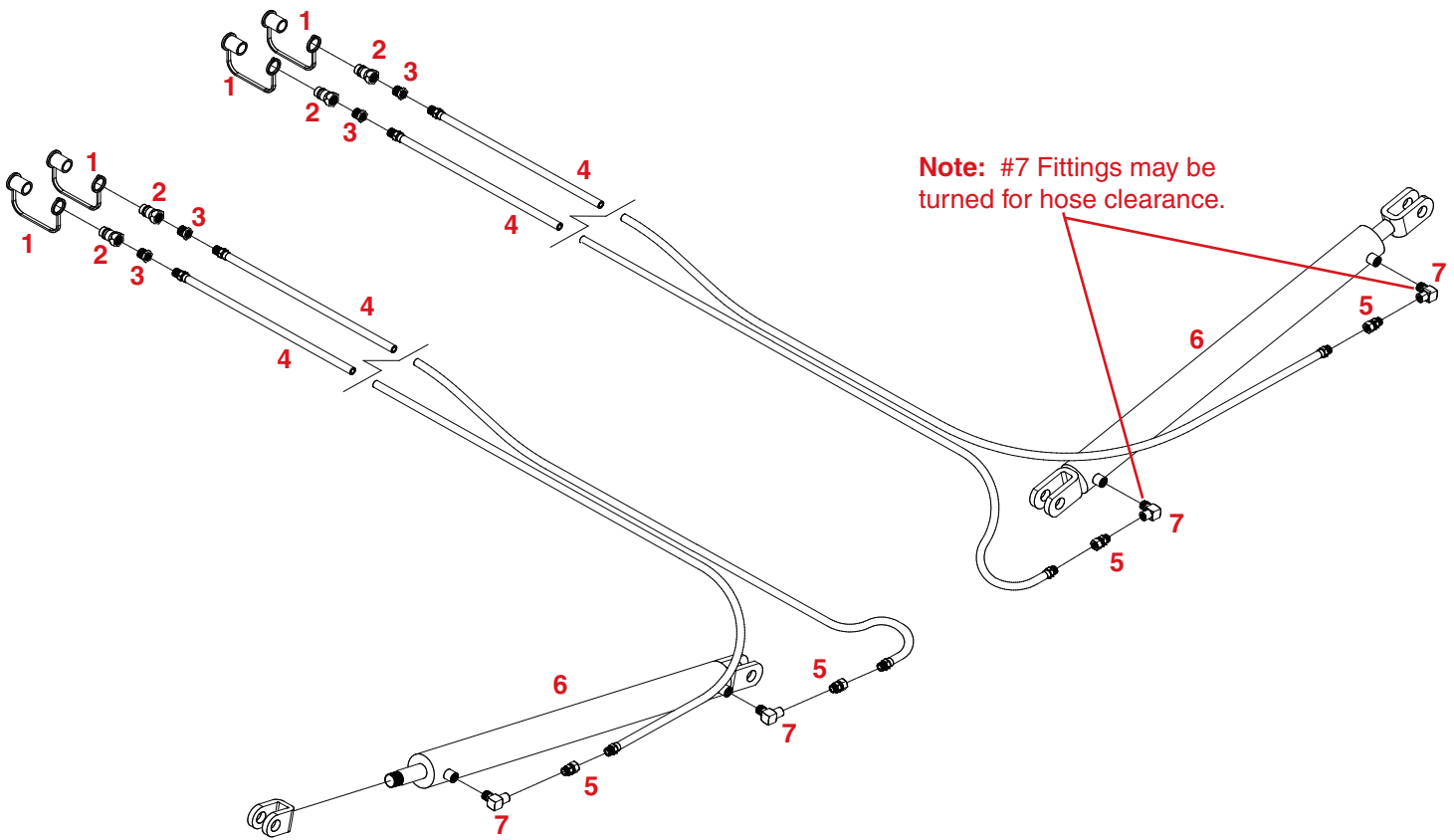

STANDARD HYDRAULICS PARTS LIST

REF NO.	PART NO.	QTY. REQD	DESCRIPTION
1.	05198	4	Rubber Female Cover for Hydraulic Coupler
2.	05197	4	Hydraulic Quick Coupler
3.	05831	4	.500 MPT x .375 FPT Reducer Bushing
4.	10750	4	1/4" x 142" Hyd. Hose with 3/8" MPT Ends
-	05841	4	1/4" x 264" Hyd. Hose with 3/8" MPT Ends
-	10547	4	1/4" x 384" Hyd. Hose with 3/8" MPT Ends
5.	05661	4	FTG, STR, 3/8" F/MPT .031 Orifice
6.	10197-30	2	2-1/2" x 29-1/4" Hydraulic Cylinder
-	5584	-	Cylinder Repair Kit for Cylinder #10197-30
-	03547	4	5/16"-18 x 2 1/4" UNC Hex Head Bolt (Gr 5)
-	02802	4	5/16"-18 UNC Nylon Insert Locknut
7.	05215	4	FTG, Elbow, 3/8" MPT x 3/8" FPT

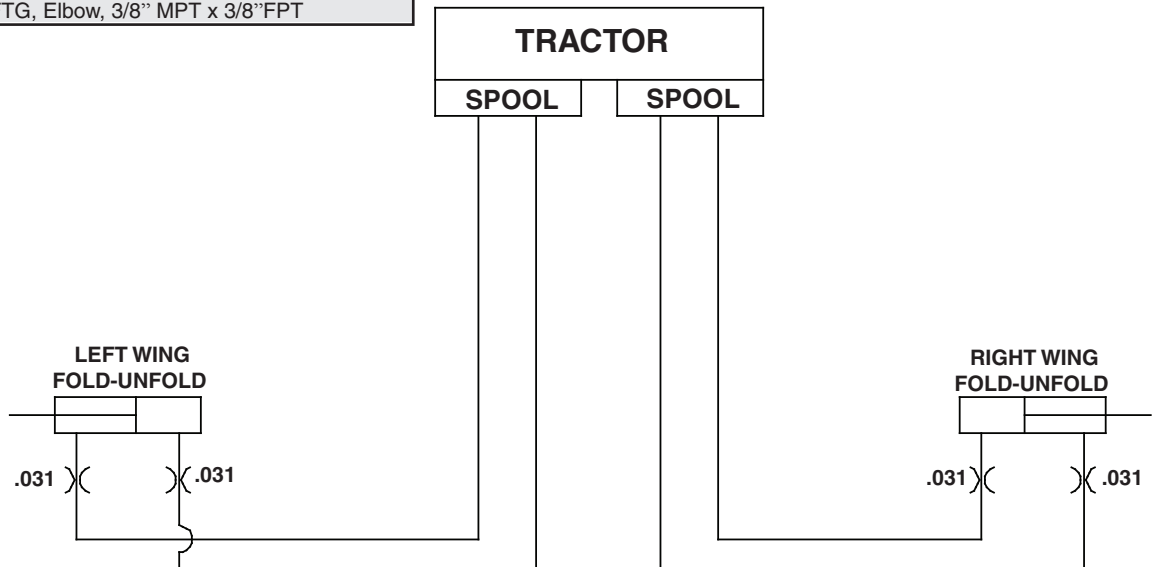
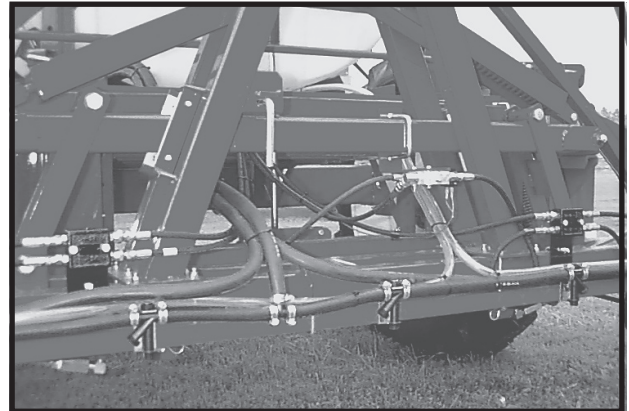

3 CYLINDER HYDRAULICS BREAKDOWN

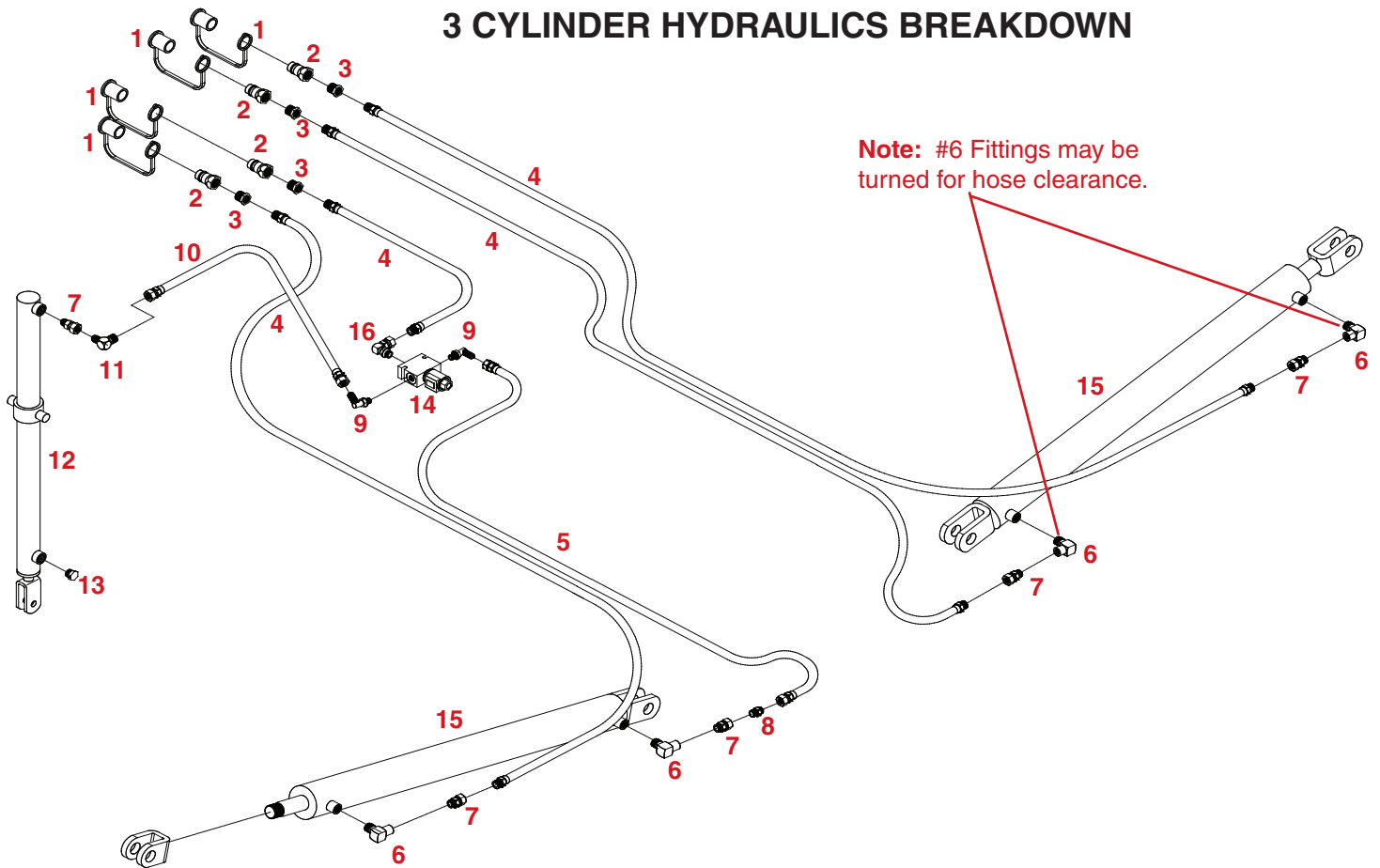

OPTIONAL HYDRAULICS PARTS LIST

REF NO.	PART NO.	QTY. REQD	DESCRIPTION
1.	05198	4	Rubber Female Cover for Hydraulic Coupler
2.	05197	4	Hydraulic Quick Coupler
3.	05831	4	.500 MPT x .375 FPT Reducer Bushing
4.	10750	4	1/4" x 142" Hyd. Hose with 3/8" MPT Ends
-	05841	4	1/4" x 264" Hyd. Hose with 3/8" MPT Ends
-	10547	4	1/4" x 384" Hyd. Hose with 3/8" MPT Ends
5.	05192	1	1/4" X 60" Hydraulic Hose
6.	05215	4	FTG, Elbow, 3/8" MPT x 3/8" FPT
7.	05661	5	FTG, STR, 3/8" F/MPT Swivel, .031 Orifice
8.	05195	1	FTG, STR, .563 M Tube x 3/8" MPT
9.	05829	2	FTG, Elbow, .563M TU x .563M Tu O-Ring
10.	05190	1	1/4" x 48" Hyd. Hose with 3/8" Female JIC ends
11.	05194	1	3/8" Male Tube - 1/4" Male Pipe Thread (90°)
12.	05600-30	1	Height Adjust Hydraulic Cylinder
13.	00288	1	Air Vent - Hydraulic Cylinder
14.	07201	1	3-Way 12 Volt DC Electric Valve
-	5584	-	Hydraulic Cylinder Repair Kit
15.	10197-30	2	2-1/2" x 29-1/4" Hydraulic Cylinder
16.	05828	1	(1) 9/16"-18 O-Ring - (2) 3/8" FPT Swivel Elbow

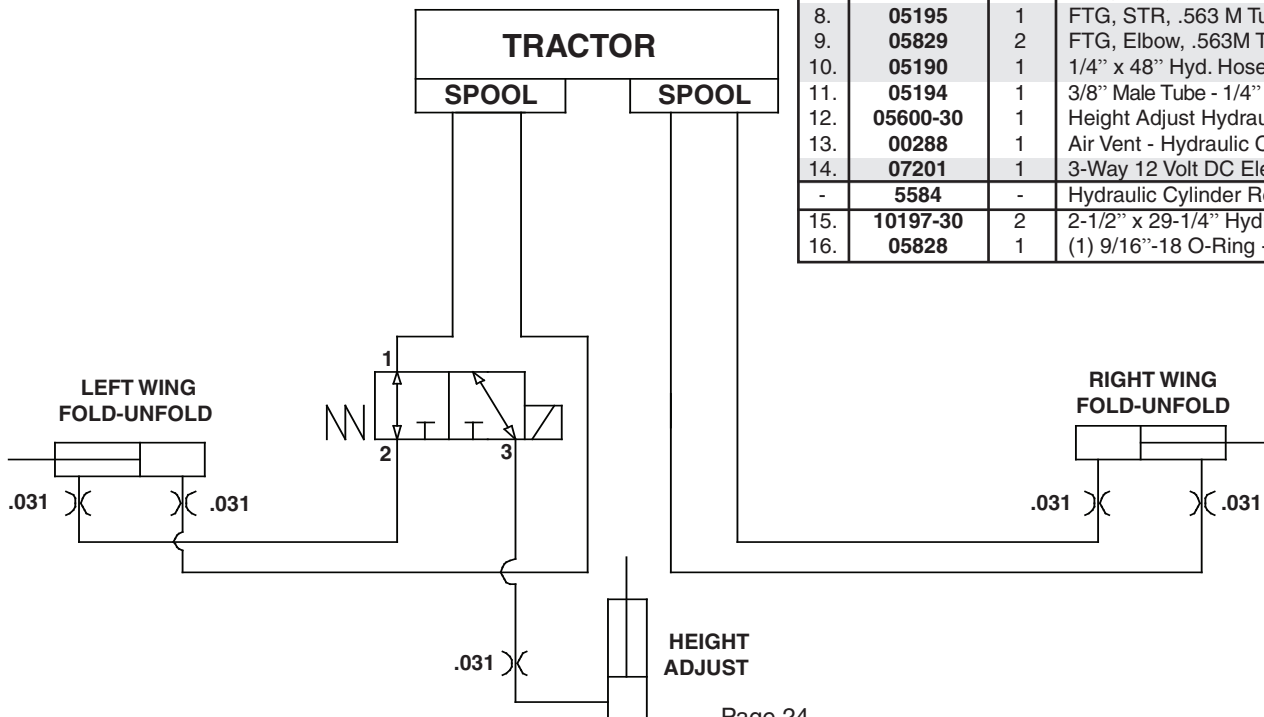

CONTROL BOX PARTS BREAKDOWN

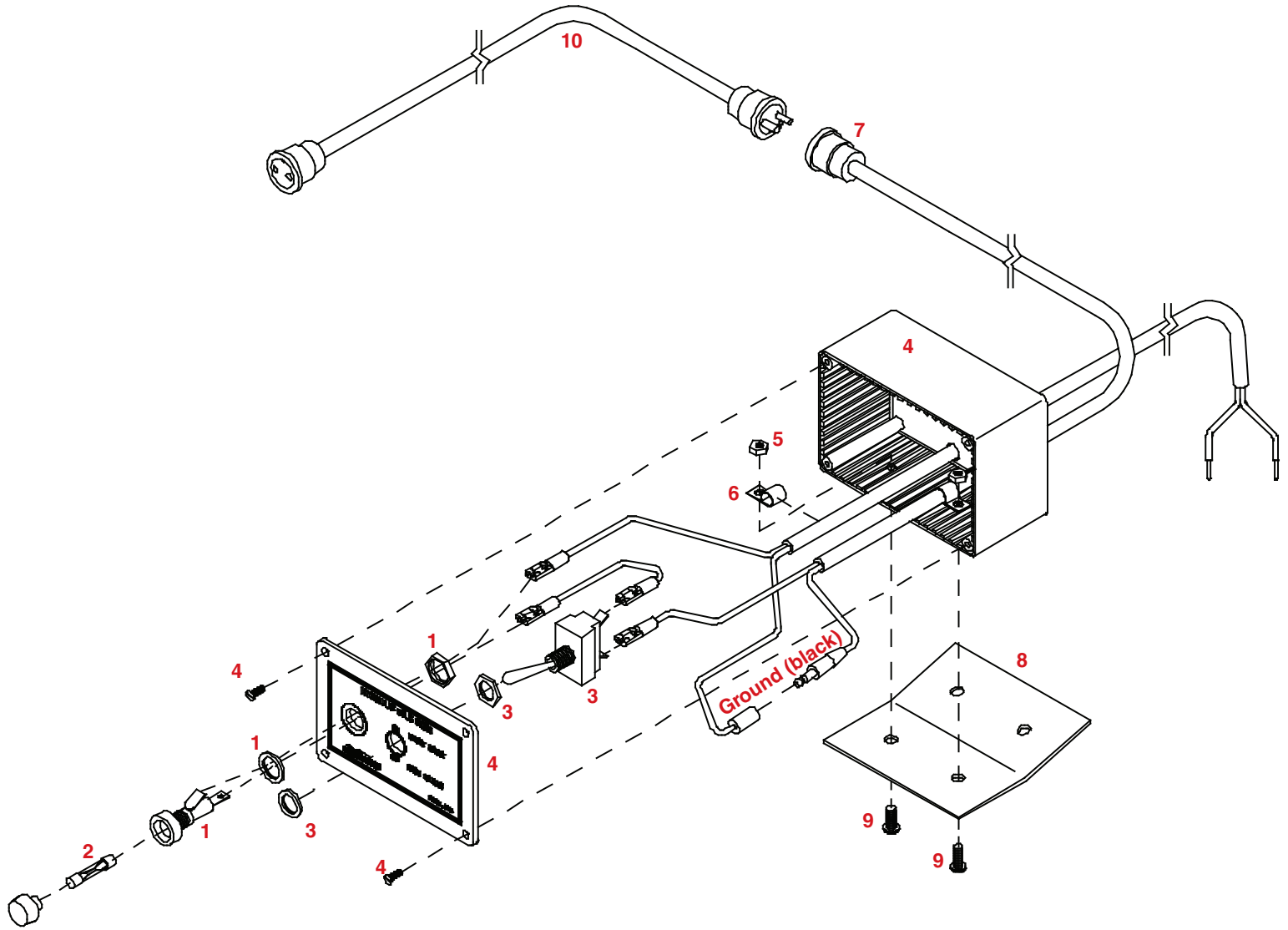

PARTS LIST

REF. NO.	PART NO.	QTY. REQD	DESCRIPTION
-	5395	-	Control Box Assembly
1.	01019	1	Fuse Holder with Locknut
2.	05480	1	15 AMP Fuse (1-1/4" long)
3.	01013	1	Switch with Locknuts
4.	05466	1	Control Box (includes Box, Face & Screws)
-	AB21008	1	Hydraulic Fold Boom Decal
5.	02205	2	#10-24 UNC Nylon Insert Locknut
6.	05491	2	Nylon Clamp #4
7.	05000	1	2 Pin Female Plug with Boot
8.	05492-95	1	Control Box Mounting Plate
9.	00568	2	#10-24 UNC x 1/2" long Machine Screw
10.	05851	1	2 Wire x 26' Extension Cable w/Plug Ends
*	01076	2	1/4"-20 UNC x 3/4" long Machine Screw
*	02772	2	1/4"-20 UNC Nylon Insert Locknut

* Used to mount control box to the tractor

Please order replacement parts by PART NO. and DESCRIPTION.

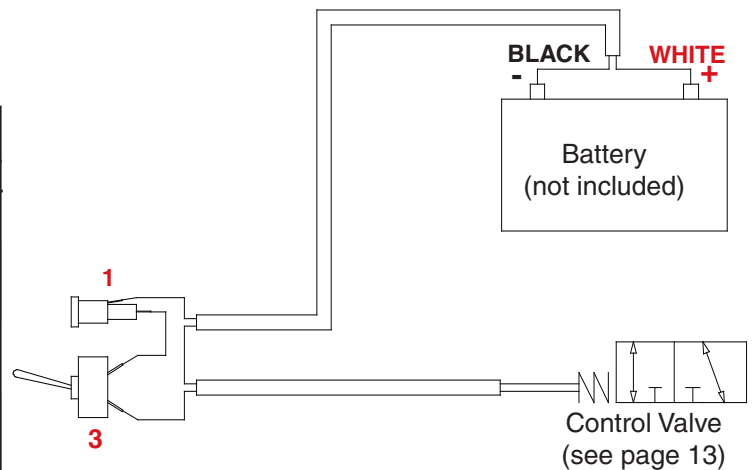

WHEEL TIP PROTECTOR

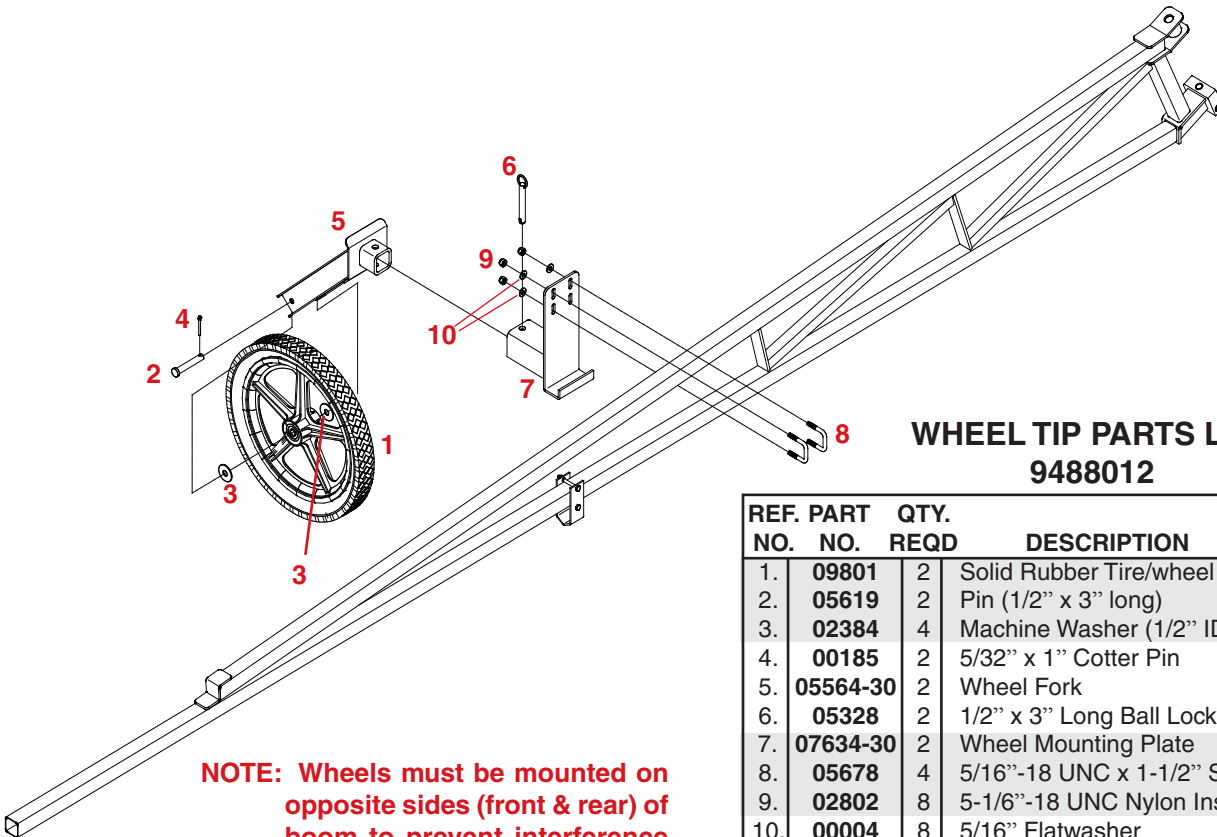

NOTE: Wheels must be mounted on opposite sides (front & rear) of boom to prevent interference during folding.

WHEEL TIP PARTS LIST 9488012

REF. NO.	PART NO.	QTY. REQD	DESCRIPTION
1.	09801	2	Solid Rubber Tire/wheel assy. 16" x 1.75"
2.	05619	2	Pin (1/2" x 3" long)
3.	02384	4	Machine Washer (1/2" ID x 14 GA.)
4.	00185	2	5/32" x 1" Cotter Pin
5.	05564-30	2	Wheel Fork
6.	05328	2	1/2" x 3" Long Ball Lock Hitch Pin
7.	07634-30	2	Wheel Mounting Plate
8.	05678	4	5/16"-18 UNC x 1-1/2" Square U-Bolt
9.	02802	8	5-1/6"-18 UNC Nylon Insert Locknut
10.	00004	8	5/16" Flatwasher

Please order replacement parts by PART NO. and DESCRIPTION.

TIP PLACEMENT

1. **Marking location of boom clamps:** Mark the clamp locations by starting at the center of the center boom section. From this mark, locate 20 inch spaces to both ends of the boom.

2. **Fasten preassembled boom lines:** Fasten the boom clamps on the boom using a stainless steel gear clamp.

NOTE: The 60 foot uses 37 spraying tips.
The 50 foot uses 31 spraying tips.
The 45 foot uses 27 spraying tips.

BASIC PLUMBING PARTS LIST

REF. NO.	PART NO.	DESCRIPTION
-	340RB	3/4" Rubber Hose
-	B12H	3/4" Gear Clamp
-	NHT11	Nylon Hose Ties

Please order replacement parts by PART NO. and DESCRIPTION.

BOOM PLUMBING & HOSE ROUTING

LEFT INNER HINGE

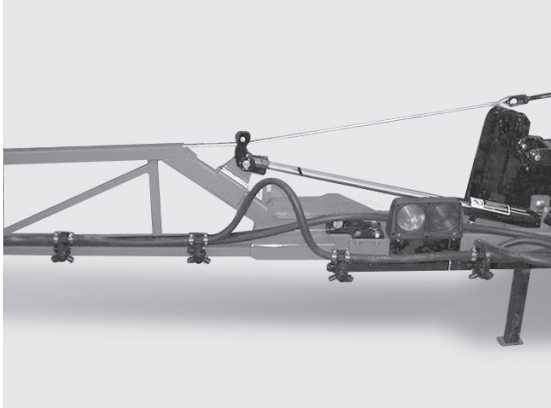

- Route the hose on the near side of the boom. Provide adequate slack for folding, just as the above picture shows.

LEFT OUTER HINGE

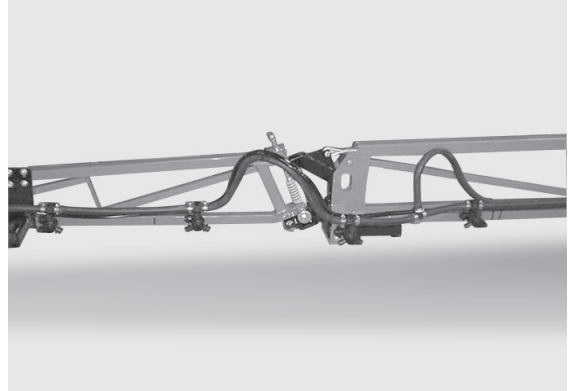

- Maintain correct spacing through out the boom. When encountering breakaway hinge, allow enough hose slack to allow for breakaway to swing fully.

RIGHT INNER HINGE

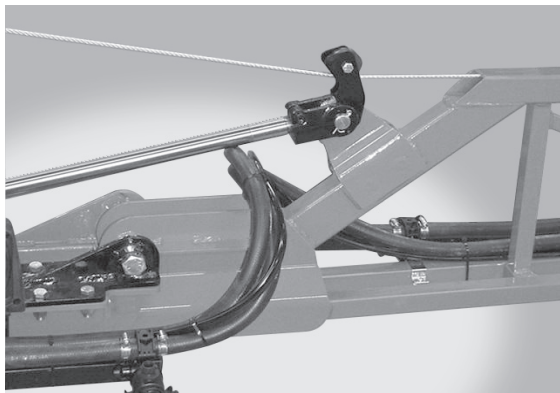

- Route the hose on the **far** side of the boom. Plumbing must be on far side of boom to prevent contact when folding. Provide enough slack for folding

RIGHT OUTER HINGE

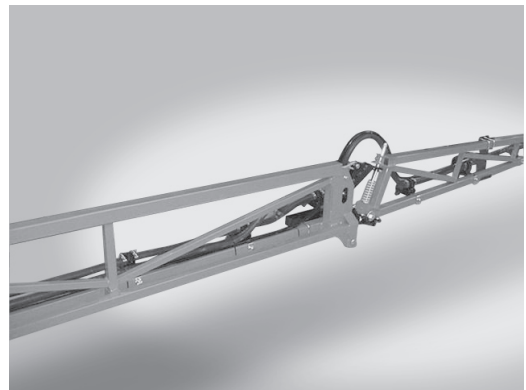

- Duplicate hose routing at this hinge just as was performed on the Left Outer Hinge. The only exception will be that hoses will be on the far side of boom. This prevents contact when folding.

TEEJET 3-WAY NOZZLES AND BOOM CLAMPS

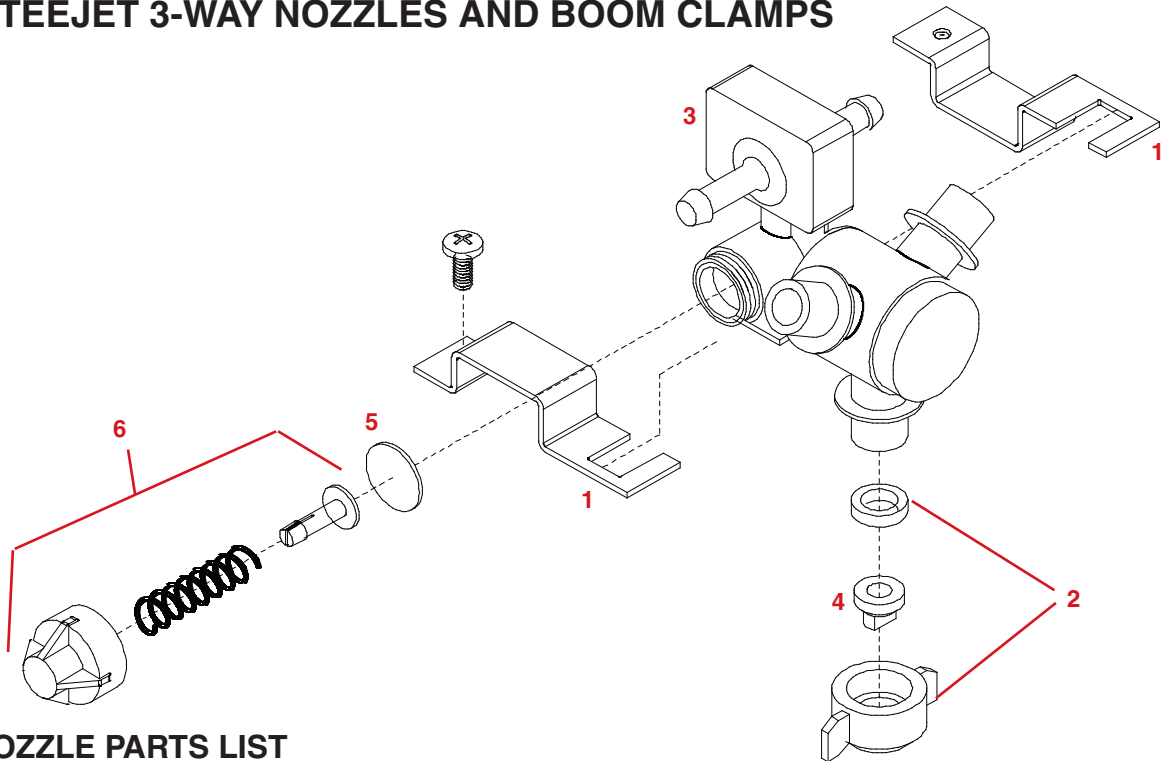

3/4" NOZZLE PARTS LIST

REF. NO.	PART NO.	DESCRIPTION
1.	10904-55	1-1/2" Sq. Boom Clamp (includes bolt)
2.	07787	Flat Fan Cap Red (includes EPDM Gasket)
-	07788	Flat Fan Cap Blue (includes EPDM Gasket)
-	07789	Flat Fan Cap Brown (includes EPDM Gasket)
3.	07782	3/4" TeeJet Nozzle Elbow
-	07783	3/4" TeeJet Nozzle Tee
4.	-----	Tip (specify tip size) (not included)
5.	21953VI	Diaphragm (viton)
6.	21950 10PP	End Cap Assembly

-55 = OFF WHITE

Please order replacement parts by PART NO. and DESCRIPTION.

TEEJET SINGLE NOZZLES AND BOOM CLAMPS

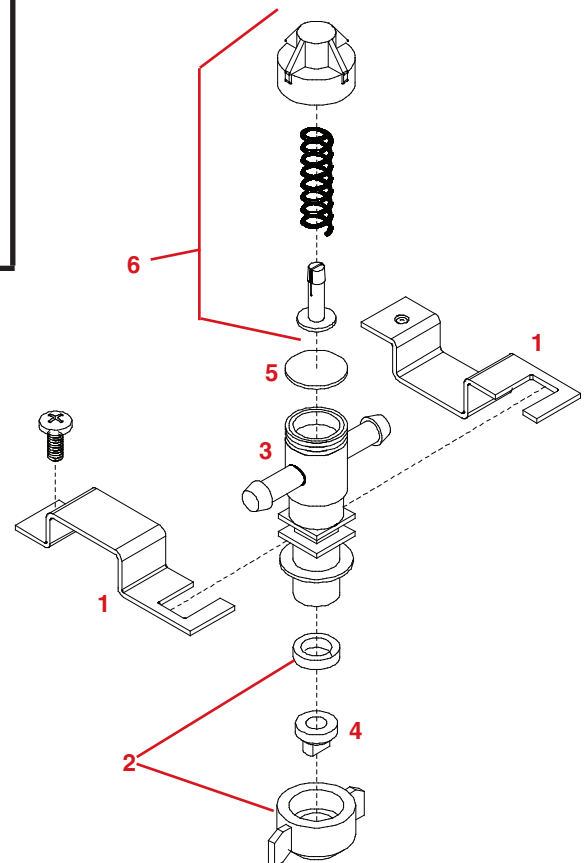

3/4" NOZZLE PARTS LIST

REF. NO.	PART NO.	DESCRIPTION
1.	10904-55	1-1/2" Sq. Boom Clamp (includes bolt)
2.	07787	Flat Fan Cap (includes EPDM Gasket)
3.	09147	3/4" TeeJet Nozzle Elbow
-	09148	3/4" TeeJet Nozzle Tee
4.	-----	Tip (specify tip size) (not included)
5.	21953VI	Diaphragm (viton)
6.	21950 10PP	End Cap Assembly

-55 = OFF WHITE

Please order replacement parts by PART NO. and DESCRIPTION.

X-FOLD BOOM OPERATING INSTRUCTIONS.

Initial Operation:

! WARNING: To avoid personal injury or property damage, observe the following instructions. Do not attempt to operate the boom until the hydraulic lines and cylinders are completely charged with hydraulic fluid. Failure to do so may cause erratic and unpredictable boom operation that may cause personal injury and physical damage to the boom. Also if the boom is equipped with a height adjust mechanism it should be latched securely. If the height adjust uses a hydraulic cylinder it is recommended to also bleed the system before operation as described below.

It is advisable to hook the cylinders up to a proper hydraulic supply and extend and retract them several times before connecting them to the boom. It is very important to remove any air from the hydraulic system before operating.

With the boom completely unfolded and supported on ground stands or sawhorses the hydraulics may be activated to collapse the cylinders and fold the boom. Initially it may be a good idea to try to bring up both wings at the same time to make sure the ride mechanism functions correctly before operating the wings individually. Make sure to collapse the cylinders, as an attempt to extend the cylinders will force the wings down and the outer wing may contact the ground or the entire wing may be lifted off the ground stands or sawhorses. Always attempt the initial folding and unfolding slowly and carefully as an incorrectly mounted bolt or hose may cause binding or allow the entire wing to drop. Also air in the lines will cause very erratic operation.

! WARNING: To avoid personal injury or property damage, observe the following instructions. Make sure whenever operating the boom that there is no one in the line of unfolding and that there are no electric lines or tree branches that will come in contact with the boom during folding or unfolding.

When doing this the first time it would be advisable to have another person standing safely behind the sprayer to ensure that none of the hoses or cables are interfering with the boom operation and that the boom is correctly folding.

After the boom has been folded into the storage cradles the first time, stop and take a moment to make sure all hoses are

routed correctly and that there are no interference problems. Examine the ride mechanism to make sure the springs are properly adjusted (see DBFT owners manual) and that there are no leaking hydraulic fittings or hoses. Make sure the cables track into the storage positions and the wings are secure in the storage positions.

To operate the boom from the folded position:

The boom is designed to be used primarily with both wings unfolded to the spraying position. Spraying with only one wing extended, could excessively twist the ride mechanism, causing damage to boom.

Activate the levers to extend the cylinders to unfold the boom. (If you have the system using only two ports on the tractor and a switch box in the cab for height adjust control, make sure this switch is in the normal (wing level/folding) position.)

! WARNING: To avoid personal injury or property damage, observe the following instructions. Always make sure the area is clear and no one will walk under the boom when it is unfolding and that there are no electric lines or tree branches that will interfere with the boom.

Unfold the wings until the boom is horizontal to the ground. The Demco boom is designed so the boom wings can be lowered below the horizontal level, if so desired, such as when spraying terraces or hilly terrain. Simply extend the cylinder further out until the boom is at the correct plane. It is always recommended to have the auto level lock pin locked out when spraying so if one wing of the boom encounters the ground it can pivot in the auto level area and not force the wing into the ground. The auto level lock pin should only be locked when folding or unfolding the boom or when spraying with only one wing extended.

Spray height should be adjusted after the boom is unfolded. After the correct height is set it is recommended that you make sure locking blocks are in their slots of the main frame. To adjust the boom height on the units with hydraulic height adjust with the switch box in the cab of the tractor, (units that use two sets of ports from the tractor) the switch in the cab must be switched on, to the height adjust position. Then actuate the corresponding hydraulic lever to raise or lower the boom to the correct position. Make sure the height adjust pins latch securely when you get to the desired spray height.

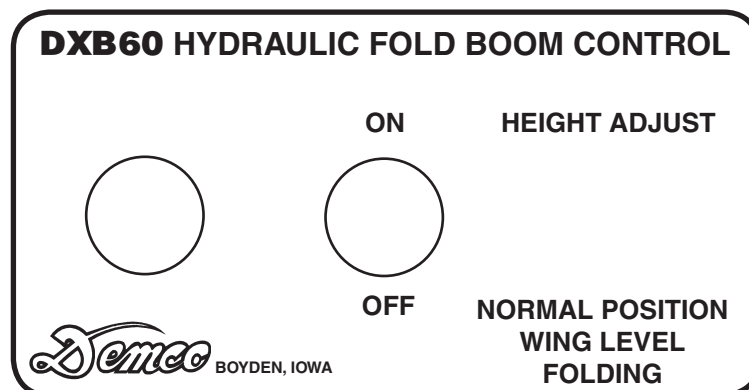

SPRAYER CALIBRATION PROCEDURES

NOTE: To avoid wind drift, use lower pressure and higher spray volume.

Guidelines For Sprayer Calibration

Calibrating the Sprayer

1. Mark off 660 feet (1/8 mile).
2. Fill the tank with water.
3. Set the sprayer to your desired operating pressure.
4. Turn the sprayer on and drive at the constant speed you will be spraying. Calibration on a road or unplowed field will give different results than on soft cultivated ground. Note tachometer reading so same speed can be maintained later.
5. Measure the amount of water it takes to refill the tank completely.
6. Calculate the amount applied:

$$\frac{\text{Number of gallons used} \times 66 (\text{factor})}{\text{Spray Swath in Feet}} = \text{Gallons applied per acre}$$

Example: If 10 gallons are used in 660 feet and the spray swath is 40 feet, spraying rate is 16.5 gallons per acre.

$$\frac{10 \times 66}{40} = \frac{660}{40} \text{ or } 16.5 \text{ gallons per acre}$$

7. To calculate the amount of chemical to put in the tank:

$$\frac{\text{Sprayer Tank Size}}{\text{Desired GPA}} = \frac{\text{Acres Covered}}{\text{then;}}$$

$$\text{Recommended amount of chemical per acre} \times \frac{\text{Acres Covered}}{\text{Amount of chemical per tankful}} = \text{Amount of chemical per tankful}$$

Example: If a 500 gallon tank is used and 16.5 gallons per acre are applied, one tank will cover 30.3 acres. If three pounds of chemical are required per acre, then 90 pounds of chemical are required per tankful.

$$\frac{500}{16.5} = 30.3 \text{ acres covered then;}$$

$$3 \text{ lbs. (gal.)} \times 30.3 = 90 \text{ lbs. (gal.) per tankful}$$

To determine GPA at other nominal speed.

Tractor Speed	Multiply by Speed Factor
4 mph	1.25
5 mph	1.00
6 mph	.83
7.5 mph	.67
10 mph	.50

Sprayer Tips

FLAT SPRAY NOZZLE for Broadcast Spraying

Nozzle No.	Liquid Pressure in PSI	Nozzle Capacity in GPM	Gallons Per Acre Based on 20" Nozzle Spacing			
			4 MPH	5 MPH	7.5 MPH	10 MPH
XR8001VS	20	.07	5.3	4.3	2.8	2.2
	25	.08	5.9	4.7	3.1	2.4
	30	.09	6.4	5.1	3.4	2.6
	40	.10	7.4	6.0	4.0	3.0
XR80015VS	20	.11	7.8	6.3	4.3	3.2
	25	.12	8.8	7.1	4.7	3.6
	30	.13	9.7	7.7	5.2	3.9
	40	.15	11.1	8.9	6.0	4.5
XR8002VS	20	.14	10.5	8.4	5.6	4.2
	25	.16	11.8	9.4	6.3	4.7
	30	.17	12.9	10.3	6.9	5.2
	40	.20	14.8	11.8	7.9	5.9
XR8003VS	20	.21	15.7	12.6	8.4	6.3
	25	.24	17.6	14.1	9.4	7.1
	30	.26	19.0	15.4	10.3	7.7
	40	.30	22.0	17.8	11.8	8.9
XR8004VS	20	.28	21.0	16.8	11.2	8.4
	25	.32	24.0	18.7	12.5	9.4
	30	.35	26.0	21.0	13.7	10.3
	40	.40	30.0	24.0	15.8	11.9
XR8005VS	20	.35	26.0	21.0	14.0	10.5
	25	.40	29.0	23.0	15.7	11.7
	30	.43	32.0	26.0	17.2	12.9
	40	.50	37.0	30.0	19.8	14.9
XR8006VS	20	.42	31.0	25.0	16.9	12.6
	25	.47	35.0	28.0	18.7	14.1
	30	.52	39.0	31.0	21.0	15.5
	40	.60	45.0	36.0	24.0	17.8
XR8008VS	20	.56	42.0	34.0	22.0	17.0
	25	.63	47.0	37.0	25.0	19.0
	30	.69	52.0	41.0	27.0	21.0
	40	.80	59.0	48.0	32.0	24.0
8010SS	20	.70	53.0	42.0	28.0	21.0
	25	.78	59.0	47.0	31.0	24.0
	30	.86	64.0	51.0	34.0	26.0
	40	1.00	74.0	59.0	40.0	30.0

To determine GPA for solutions other than water, determine the weight per gallon or specific gravity and use the following conversion table.

Weight per Gallon	Specific Gravity	Multiply By
7.0 lbs.	.84	1.09
8.0 lbs.	.96	1.02
8.34 lbs. (water)	1.00	1.00
9.0 lbs.	1.08	.96
10.0 lbs.	1.20	.91
11.0 lbs.	1.32	.87
12.0 lbs.	1.44	.83

SPRAYER CHECKLIST:

Downtime caused by field breakdowns is costly and time consuming. Many breakdowns can be eliminated by periodic equipment maintenance. By spending time reviewing this checklist before seasonal spraying application time and following proper after-season care, you can save time and money later.



WARNING: To Prevent Serious Injury Or Death

- Keep hands, feet, and loose clothing away from rotating parts.
- Wear protective clothing recommended by your chemical and fertilizer manufacturer when working with chemicals.

Check Before Going To The Field :

1. NOZZLES

Check tip for excessive wear by checking for grooves in or near tip opening. Check nozzle spacing by starting at center and working outwards. Check boom for proper height.

2. HOSES

Check all hoses for worn or soft spots. Be sure all hose clamps are tightened and hoses are not kinked or pinched. Check for leakage in any lines.

3. TANK

Remove and clean agitator orifices. Check orifices for excessive wear by checking for grooves in or near orifice opening. Inspect fitting and grommets to insure they are in good condition.

4. CONTROLS

Check for leakage, plugging, or wear on all valves, fittings, etc. Clean off any build up of foreign material.

5. PUMP

Check to be sure pump turns freely.

6. FRAME

Be sure all bolts are tightened.

7. REPLACEMENT PARTS

Replace all worn or damaged parts.

After Season Care:

NOTE: It is important to wear proper safety equipment when cleaning the sprayer. See your chemical or fertilizer package for this information.

1. After spraying chemicals, run water mixed with cleaners through tank, pump and all hose hookups. If wettable powder dries out in the system, it is very difficult to put back into suspension and can cause malfunction, damage or injury.
2. When cleaned, tank should have all openings closed or covered to keep dirt from entering.
3. Pump should be flushed with soluble oil and pump ports plugged to keep out moisture and air.
4. Disassemble tips and rinse with water or cleaning solution. (Appropriate for chemical sprayed).
5. Clean tip opening with a wooden toothpick. Never use wire or hard object that could distort opening.
6. Dispose of all unused chemicals or solutions in a proper and ecologically sound manner.
7. Water rinse and dry tips before storing.

NOTE: DEMCO does not and will not make any recommendations concerning application of various chemicals or solutions. These recommendations relate to either amount or procedure of materials applied. If you have any questions regarding application of certain chemicals or solutions, contact your chemical supplier and follow chemical manufacturer recommendations.



P.O. BOX 189
4010 320th St., BOYDEN, IA. 51234
PH: (712) 725-2311
FAX: (712) 725-2380
TOLL FREE: 1-800-54DEMCO (1-800-543-3626)
www.demco-products.com