

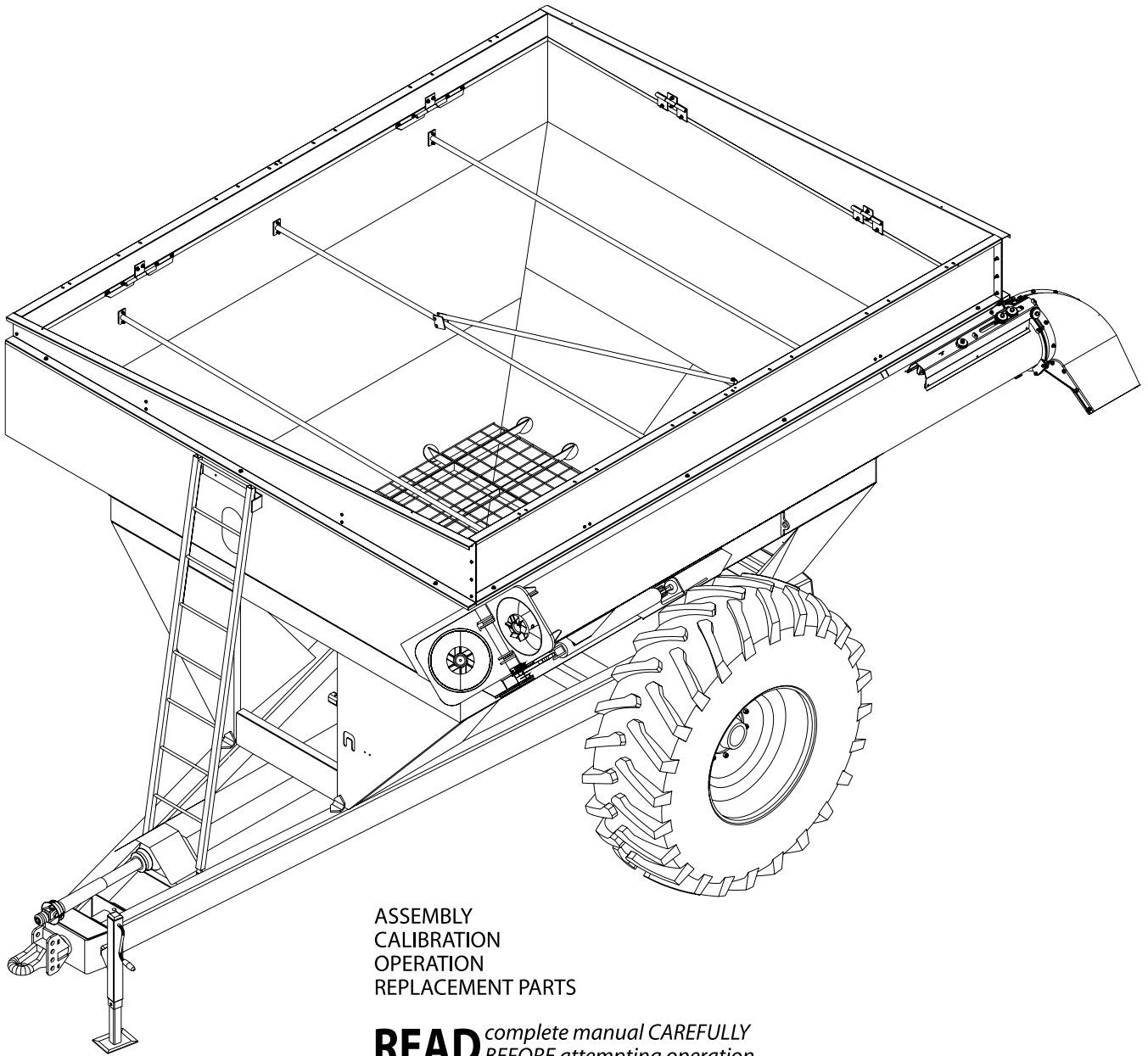

Demco

GRAIN CART

550-650-750 BUSHEL



Doing Our Best To Provide You The Best

MANUAL
OPERATORS

INTRODUCTION

Thank you for purchasing a Demco Grain Cart. We feel you have made a wise choice and hope you are completely satisfied with your new piece of equipment. Proper care and use will result in many years of service.



WARNING: TO AVOID PERSONAL INJURY OR DEATH, OBSERVE FOLLOWING INSTRUCTIONS:

Ensure that anybody present is clear before applying power to any machinery used in conjunction with grain cart or when moving grain cart.

Never allow anyone in, near, or on grain cart during transporting or unloading of grain. Moving grain is dangerous and can cause entrapment, resulting in severe injury or death by suffocation.

Do not exceed 20 miles per hour when towing grain cart.

GENERAL INFORMATION

- Unless otherwise specified, high-strength (grade5) (3 radial-line head markings) hex head bolts are used throughout assembly of this piece of equipment.*
- Whenever terms “LEFT” and “RIGHT” are used in this manual it means from a position behind wagon box and facing forward.*
- When placing a parts order, refer to this manual for*
- proper part numbers and place order by **PART NO. and DESCRIPTION.***
- Read assembly instructions carefully. Study assembly procedures and all illustrations before you begin assembly. Note which parts are used in each step. This unit must be assembled in proper sequence or complications will result.*

Table of Contents

General information, Table of Contents	2
Warranty Registration.....	3-4
Safety, Signal Words	5
Equipment Safety Guidelines, Lighting and Marking	6
Safety Sign Care, Tire Safety	7
Before Operation	8
During Operation.....	8-9
Following Operation	9
Highway and Transport Operations	9-10
Performing Maintenance	11
Safety Sign Locations	12-13
Bolt Torque	14
Axle Assembly and Parts Breakdown	15
Auger Assembly and Parts Breakdown.....	16
Adjustable Discharge Chute Option Parts Breakdown.....	17
Grain Cart Assembly and Parts Breakdown.....	18-19
650 Bushel Extensions Assembly and Parts Breakdown.....	20
750 Bushel Extensions Assembly and Parts Breakdown.....	21
Hydraulics Assembly and Parts Breakdown.....	22
Optional Hydraulic Block Schematic	23
Lighting Assembly and Parts Breakdown.....	24
Scale Option and Parts Breakdown	25
PTO Drive Shaft Breakdown	26
Hydraulic Drive Assembly and Parts Breakdown	27
Window Assembly and Door Lift Assembly Breakdown.....	28
Grease and Lube Instructions	29
Inner Door Maintenance, Gear Box Lube Instructions	30
Grain Cart Checklist, Tire Inflation	31



Warranty Registration

4010 320th Street • Box 189 • Boyden, Iowa 51234
Toll Free 800-54DEMCO (800-543-3626) • FAX 800-845-6420
www.demco-products.com

Ag	<input type="radio"/>
RV	<input type="radio"/>
Rental	<input type="radio"/>
Brakes	<input type="radio"/>
Marine	<input type="radio"/>

	Very Satisfied	Satisfied	Dissatisfied	Very Dissatisfied
How satisfied are you with our product?	<input type="radio"/>	<input type="radio"/>	<input type="radio"/>	<input type="radio"/>
How satisfied are you with the dealership/distributor sales staff? Dealer/Distributor Name _____ City _____ State _____	<input type="radio"/>	<input type="radio"/>	<input type="radio"/>	<input type="radio"/>
How satisfied are you with the company sales staff?	<input type="radio"/>	<input type="radio"/>	<input type="radio"/>	<input type="radio"/>
How satisfied are you with the delivery?	<input type="radio"/>	<input type="radio"/>	<input type="radio"/>	<input type="radio"/>
Did you have any contact with a Demco Representative? If YES , how satisfied were you?	YES <input type="radio"/>	NO <input type="radio"/>	<input type="radio"/>	<input type="radio"/>
I would recommend this product to my family and friends.	YES	NO		
Would you purchase again from DEMCO?	YES	NO		
Since taking delivery, have you been contacted by the dealer?	YES	NO		
Did you have any problems with this DEMCO product? If YES , are you satisfied with the company's resolution of your problem?	YES <input type="radio"/>	NO <input type="radio"/>	<input type="radio"/>	<input type="radio"/>

Please list the specific source of information prompting this purchase.

After purchasing this product, do you see any needed product improvement? _____ If yes, what improvement? _____

What other products would you like to see DEMCO offer? _____

Comments _____

Owner's Name: _____ Mailing Address: _____

City: _____ State: _____ Zip Code: _____

Model#: _____

Serial #: _____

Purchase Date: _____

Owner's Signature: _____

Please return to DEMCO By FAX or tri-folding this form to the backside, it is pre-addressed.

Postage

*Demco
4010 320th Street, Box 189
Boyden, Iowa 51234*

SAFETY

TAKE NOTE! THIS SAFETY ALERT SYMBOL FOUND THROUGHOUT THIS MANUAL IS USED TO CALL YOUR ATTENTION TO INSTRUCTIONS INVOLVING YOUR PERSONAL SAFETY AND SAFETY OF OTHERS. FAILURE TO FOLLOW THESE INSTRUCTIONS CAN RESULT IN INJURY OR DEATH!



THIS SYMBOL MEANS

ATTENTION

BECOME ALERT

YOUR SAFETY IS INVOLVED!

SIGNAL WORDS:

This manual uses of the following signal words-- **DANGER, WARNING, and CAUTION**-- with safety messages. The appropriate signal word has been selected using the following guidelines.

DANGER:

Indicates an imminently hazardous situation that, if not avoided, will result in death or serious injury. This signal word is to be limited to most extreme situations typically for machine components which, for functional purposes, cannot be guarded.

WARNING:

Indicates a potentially hazardous situation that, if not avoided, could result in death or serious injury, and includes hazards that are exposed when guards are removed. It may also be used to alert against unsafe practices.

CAUTION:

Indicates a potentially hazardous situation that, if not avoided, may result in minor or moderate injury. It may also be used to alert against unsafe practices.

If you have questions not answered in this manual, require additional copies, or if your manual is damaged, please contact your dealer or Demco, P.O. Box 189, 4010 320th Street, Boyden, IA 51234
ph: (712) 725-2311 or Toll Free: 1-800-543-3626 Fax: (712) 725-2380
<http://www.demco-products.com>



SAFETY...YOU CAN LIVE WITH IT



EQUIPMENT SAFETY GUIDELINES

Every year many accidents occur which could have been avoided by a few seconds of thought and a more careful approach to handling equipment. You, the operator, can avoid many accidents by observing the following precautions in this section. To avoid personal injury, study the following precautions and insist those working with you, or you yourself, follow them.

In order to provide a better view, certain illustrations in your owners manual may show an assembly with a safety shield removed. However, equipment should never be operated in this condition. Keep all shields in place. If shield removal becomes necessary for repairs, replace shield prior to use.

Replace any caution, warning, danger or instruction safety decal that is not readable or is missing.

Do not attempt to operate this equipment under the influence of alcohol or drugs.

Review safety instructions with all users annually.

Operator should be a responsible adult. **DO NOT ALLOW PERSONS TO OPERATE OR ASSEMBLE THIS UNIT UNTIL THEY HAVE DEVELOPED A THOROUGH UNDERSTANDING OF SAFETY PRECAUTIONS AND HOW IT WORKS.**

To prevent injury or death, use a tractor equipped with a roll over protective system (ROPS). Do not paint over, remove, or deface any safety signs or warning decals on your equipment. Observe all safety signs and practice instructions on them.

Never exceed limits of a piece of machinery. If its ability to do a job, or to do so safely is in question **DON'T TRY IT.**



LIGHTING AND MARKING

It is the responsibility of customer to know lighting and marking requirements of local highway authorities and to install and maintain equipment to provide compliance with regulations. Add extra lights when transporting at night or during periods of limited visibility.

Lighting kits are available from your dealer or from manufacturer.



SAFETY SIGN CARE

- Keep safety signs clean and legible at all times.
- Replace safety signs that are missing or have become illegible.
- Replacement parts that displayed a safety sign should also display current sign.
- Safety signs are available from your distributor, dealer parts department, or factory.

How to install safety signs:

- Be sure that installation area is clean and dry.
- Decide on exact position before you remove backing paper.
- Remove smallest portion of split backing paper.
- Align decal over specified area and carefully press small portion with exposed sticky backing in place.
- Slowly peel back remaining paper and carefully smooth remaining portion of decal into place.
- Small air pockets can be pierced with a pin and smoothed out using piece of decal backing paper.



TIRE SAFETY

- Failure to follow proper procedures when mounting a tire on a rim can produce an explosion which may result in a serious injury or death.
- Do not attempt to mount a tire unless you have proper equipment and experience to do job.
- Inflating or servicing tires can be dangerous. Whenever possible, trained personnel should be called to service and/or mount tires.
- Always order and install tires and wheels with appropriate type and load capacity to meet or exceed anticipated weight to be placed on the equipment.
- **NEVER** exceed 40 psi tire inflation when using truck tires on gravity flow wagons.
- Refer to “**TIRE INFLATION CHART**” in your owners manual for maximum tire pressure for a Demco Grain Cart.



REMEMBER

Your best assurance against accidents is a careful and responsible operator. If there is any portion of this manual or function you do not understand, contact your local authorized dealer or manufacturer.



BEFORE OPERATION:

- Carefully study and understand this manual and the Owner's Manual.
- Do not wear loose-fitting clothing which may catch in moving parts.
- Always wear protective clothing and substantial shoes.
- It is recommended that suitable protective hearing and eye protection be worn.
- Operator may come in contact with certain materials which may require specific safety equipment relative to handling of such materials. (Examples: extremely dusty, molds, fungus, bulk fertilizers, etc.)
- Keep wheel and lug nuts tightened to specified torque.
- Assure that agricultural implement tires are inflated evenly.
- Give unit a visual inspection for any loose bolts, worn parts, or cracked welds, and make necessary repairs. Follow maintenance safety instructions included in this manual.
- Be sure there are no tools lying on or in equipment
- Do not use unit until you are sure that area is clear, especially around children and animals.
- Don't hurry learning process or take unit for granted. Ease into it and become familiar with your new equipment.
- Practice operation of your equipment and its attachments. Completely familiarize yourself and other operators with its operation before using.
- Make sure that brakes are evenly adjusted (if equipped with brakes)
- Use a tractor equipped with Roll Over Protection System (ROPS) and fasten your seat belt prior to starting the engine.
- Manufacturer does not recommend usage of a tractor with the ROPS removed.
- Move tractor wheels to widest recommended settings to increase stability.
- Do not allow anyone to stand between tongue or hitch and towing vehicle when backing up to equipment.



DURING OPERATION

- Beware of bystanders, **PARTICULARLY CHILDREN!** Always look around to make sure that it is safe to start engine of towing vehicle or move unit. This is particularly important with higher noise levels and quiet cabs, as you may not hear people shouting.
- **NO PASSENGERS ALLOWED-** Do not carry passengers anywhere on or in tractor or equipment.
- Keep hands and clothing clear of moving parts.
- Do not clean, lubricate, or adjust your equipment while it is moving.

- When halting operation, even periodically, set tractor or towing vehicles brakes, disengage PTO, shut off engine, and **remove ignition key**.
- Be especially observant of operating area and terrain. Watch for holes, rocks, or other hidden hazards. Always inspect area prior to operation.
 - DO NOT operate near edge of drop-off or banks.
 - DO NOT operate on steep slopes as overturn may result.
 - Operate up and down (not across) intermediate slopes. Avoid sudden starts and stops.
- Pick the most level possible route when transporting across fields. Avoid edges of ditches, gullies, and steep hillsides.
- Be extra careful when working on inclines.
- Maneuver tractor or towing vehicle at safe speeds.
- Avoid overhead wires or other obstacles. Contact with overhead lines could cause serious injury or death.
- Avoid loose gravel, rocks, and holes; they can be dangerous for equipment operation or movement.
- Allow for unit length when making turns.
- Do not walk or work under raised components or attachments unless securely positioned and blocked.
- Keep all bystanders, pets, and livestock clear of work area.
- Operate towing vehicle from operators seat only.
- Never stand alongside of unit with engine running or attempt to start engine and/or operate machine while standing alongside of unit.
- Never leave running equipment unattended.
- As a precaution, always recheck hardware on equipment following every 100 hours of operation. Correct all problems. Follow maintenance safety procedures.



FOLLOWING OPERATION

- Following operation, or when unhitching, stop tractor or towing vehicle, set brakes, shut off engine and **remove ignition key**.
- Store unit in an area away from human activity.
- Do not park equipment where it will be exposed to livestock for long periods of time. Damage and livestock injury could result.
- Do not permit children to play on or around stored unit.
- Make sure all parked machines are on a hard, level surface and engage all safety devices.
- Wheel chocks may be needed to prevent unit from rolling.



HIGHWAY AND TRANSPORT OPERATIONS

- **SAFETY CHAINS:** If equipment is going to be transported on a public highway, always follow state and local regulations regarding safety chains and auxiliary lighting. Be sure to check with local law enforcement agencies for your own particular regulations. Only safety chains (not elastic or nylon/plastic tow straps) should be used to retain connection between towing and towed machines in event of separation of primary attaching system. Use a high strength, appropriately sized hitch pin with a mechanical retainer and attach safety chains. Criss cross chains under tongue and secure to draw bar cage, mounting loops, or bumper frame.
- Adopt safe driving practices:
 - Keep brake pedals latched together at all times. **NEVER USE INDEPENDENT BRAKING WITH MACHINE IN TOW, LOSS OF CONTROL AND/OR UPSET OF UNIT CAN RESULT.**
 - Always drive at a safe speed relative to local conditions, ensure that your speed is low enough for an emergency stop. Keep speed to a minimum.
 - Reduce speed prior to turns to avoid risk of overturning.
 - Always keep tractor or towing vehicle in gear to provide engine braking when going downhill. Do not coast.
 - Do not drink and drive!
- Comply with state and local laws governing highway safety and movement of farm machinery on public roads.
- Use approved accessory lighting, flags and necessary warning devices to protect operators of other vehicles on highway during transport. Various safety lights and devices are available from your dealer.
- Use of flashing amber lights is acceptable in most localities. However, some localities prohibit their use. Local laws should be checked for all highway lighting and marking requirements.
- When driving tractor and equipment on road under 20 m.p.h. (40 kph) at night or during day, use flashing amber warning lights and a slow moving vehicle (SMV) identification emblem.
- Plan your route to avoid heavy traffic.
- Be a safe and courteous driver. Always yield to oncoming traffic in all situations, including narrow bridges, intersections, etc.
- Be observant of bridge load ratings. Do not cross bridges rated lower than gross weight at which you are operating.

- Watch for obstructions overhead and side to side while transporting.
- Always operate equipment in a position to provide maximum visibility. Make allowances for increased length and weight of equipment when making turns, stopping unit, etc.



PERFORMING MAINTENANCE

- Good maintenance is your responsibility. Poor maintenance is an invitation to trouble.
- Make sure there is plenty of ventilation. Never operate engine of towing vehicle in a closed building. Exhaust fumes may cause asphyxiation.
- Before working on this machine, stop towing vehicle, set brakes, shut off engine and **remove ignition key**.
- Always use safety support and block wheels. Never use a jack to support machine.
- Always use proper tools or equipment for job at hand.
- Use extreme caution when making adjustments.
- Follow torque chart in owners manual when tightening bolts and nuts.
- Never use your hands to locate a hydraulic leak on attachments. Use a small piece of cardboard or wood. Hydraulic fluid escaping under pressure can penetrate skin.
- Openings in skin and minor cuts are susceptible to infection from hydraulic fluid. **Without immediate medical treatment, serious infection and reactions can occur.**
- When disconnecting hydraulic lines, shut off hydraulic supply and relieve all hydraulic pressure.
- Replace **all shields** and **guards** after servicing and before moving.
- After servicing, be sure all tools, parts and service equipment are removed.
- Do not allow grease or oil to build up on any steps or platform.
- When replacing bolts, refer to owners manual.
- Refer to bolt torque chart in owners manual for head identification marking.
- Where replacement parts are necessary for periodic maintenance and servicing, genuine factory replacement parts must be used to restore your equipment to original specifications. Manufacturer will not claim responsibility for use of unapproved parts or accessories and other damages as a result of their use.
- If equipment has been altered in any way from original design, manufacturer does not accept any liability for injury or warranty.
- A fire extinguisher and first aid kit should be kept readily accessible while performing maintenance on this equipment



SAFETY SIGN LOCATIONS

Types of safety sign and locations on equipment are shown in illustration below. Good safety requires that you familiarize yourself with various safety signs, type of warning, and area or particular function related to that area, that requires your SAFETY AWARENESS.

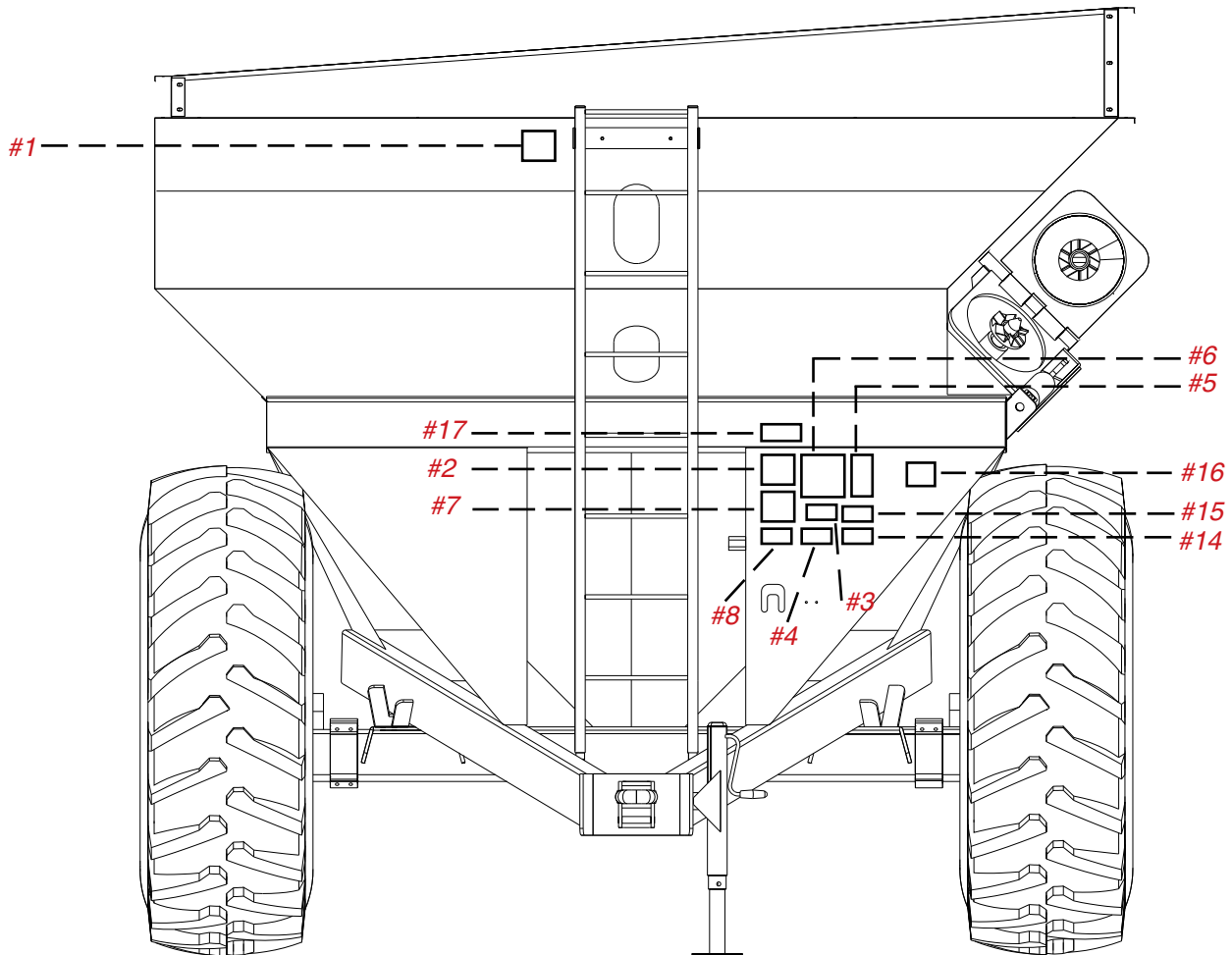

- #1 DANGER - Do not enter grain tank when auger is running!
- #2 DANGER - Keep off ladder while machine is being moved or in operation!
- #3 WARNING - Read and understand the operator's manual!
- #4 WARNING - Keep hands and clothing away from moving parts!
- #5 DANGER - Never play in or on grain! Farm safety just 4 kids!
- #6 DANGER - Electrocution can occur without direct contact with power lines !
- #7 WARNING - Read manual, keep all shields in place, cleaning or clearing a clogged machine, keep hands, feet, and clothing away, do not stand or climb on machine, no riders!
- #8 WARNING - Avoid bodily injuries from hydraulic oil under pressure.



SAFETY SIGN LOCATIONS

Types of safety sign and locations on equipment are shown in illustration below. Good safety requires that you familiarize yourself with various safety signs, type of warning, and area or particular function related to that area, that requires your SAFETY AWARENESS.

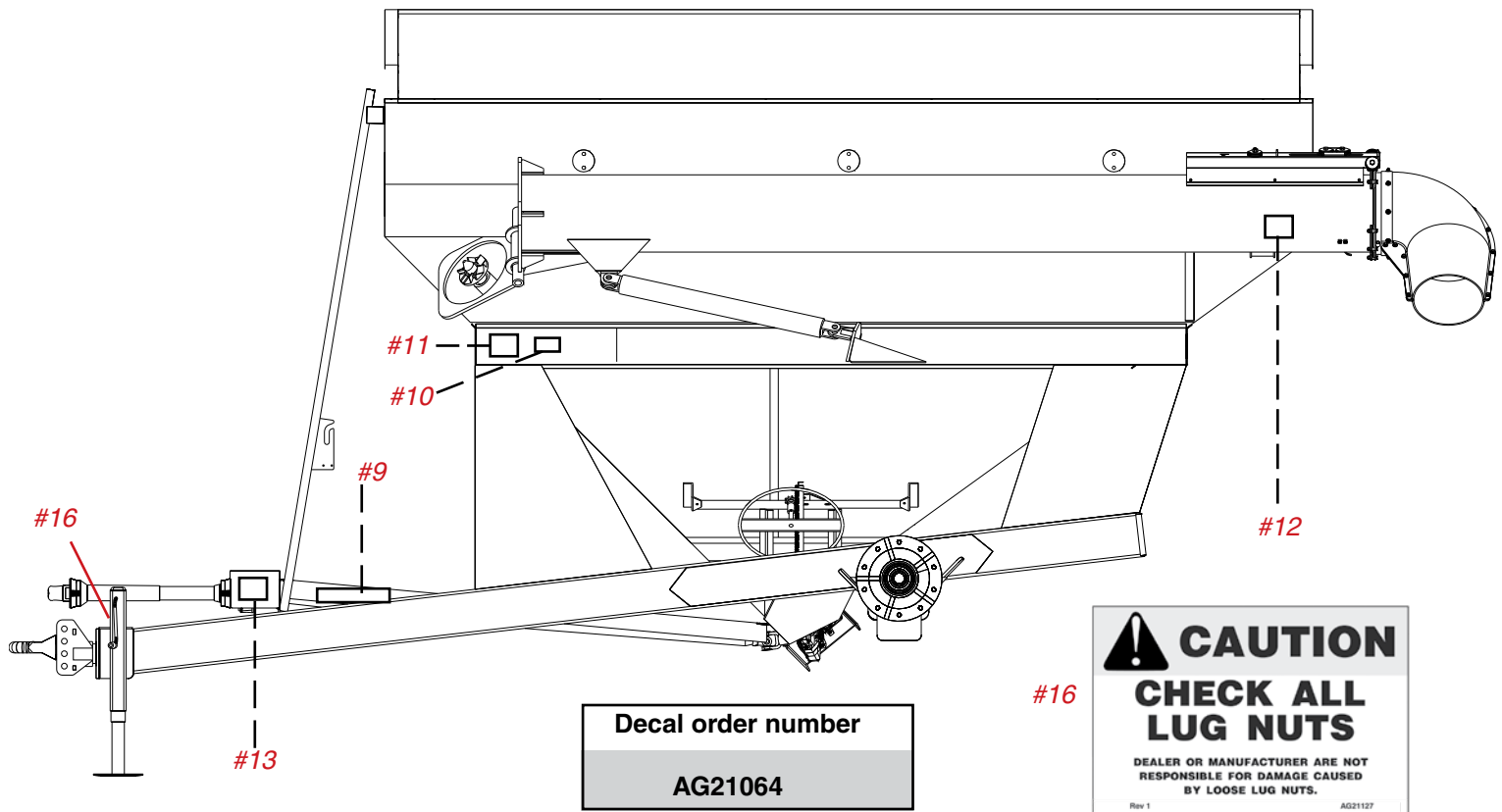

- # 9 DANGER - This decal is on pto shaft, Guard is missing do not operate!
- #10 DANGER - Pinch- point keep hands and clothing away from moving parts!
- #11 WARNING - Keep all persons and objects clear while any part of this machine is in motion!
- #12 DANGER - Electrocutation can occur without direct contact with power lines!
- #13 DANGER - Rotating driveline!
- #14 WARNING - Do not exceed 20 mph when towing the grain cart!
- #15 WARNING - Local and state weight restrictions and regulations may affect use of this equipment on public roads and highways!
- Decal Kit - Decals #1-#15 are available as a kit.

-
- #16 CAUTION - Check all wheel nuts. Dealer or Manufacturer are not responsible for damage caused by loose wheel nuts. (AG21127, Qty 2)
This decal is not part of the decal kit.
 - #17 WARNING - For increased life of the track system & grain cart, avoid sharp turns. (AG21185, Qty 1) This decal is not part of the decal kit.

BOLT TORQUE

TORQUE DATA FOR STANDARD NUTS, BOLTS, AND CAPSCREWS.



Torque Specifications

Bolt Torque for Standard bolts *

"A"	GRADE 2		GRADE 5		GRADE 8	
	lb-ft	(N.m)	lb-ft	(N.m)	lb-ft	(N.m)
1/4"	6	(8)	9	(12)	12	(16)
5/16"	10	(13)	18	(25)	25	(35)
3/8"	20	(27)	30	(40)	45	(60)
7/16"	30	(40)	50	(70)	80	(110)
1/2"	45	(60)	75	(100)	115	(155)
9/16"	70	(95)	115	(155)	165	(220)
5/8"	95	(130)	150	(200)	225	(300)
3/4"	165	(225)	290	(390)	400	(540)
7/8"	170	(230)	420	(570)	650	(880)
1"	225	(300)	630	(850)	970	(1310)

Bolt Torque for Metric bolts *

"A"	CLASS 8.8		CLASS 9.8		CLASS 10.9	
	lb-ft	(N.m)	lb-ft	(N.m)	lb-ft	(N.m)
6	9	(13)	10	(14)	13	(17)
7	15	(21)	18	(24)	21	(29)
8	23	(31)	25	(34)	31	(42)
10	45	(61)	50	(68)	61	(83)
12	78	(106)	88	(118)	106	(144)
14	125	(169)	140	(189)	170	(230)
16	194	(263)	216	(293)	263	(357)
18	268	(363)	--	--	364	(493)
20	378	(513)	--	--	515	(689)
22	516	(699)	--	--	702	(952)
24	654	(886)	--	--	890	(1206)

Torque figures indicated are valid for non-greased or non-oiled threads and heads unless otherwise specified. Therefore, do not grease or oil bolts or capscrews unless otherwise specified in this manual. When using locking elements, increase torque values by 5%.

* GRADE or CLASS value for bolts and capscrews are identified by their head markings.

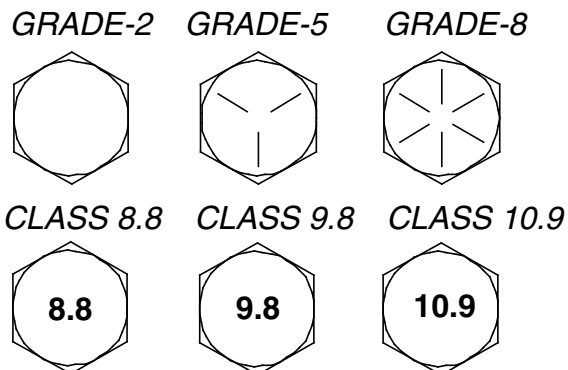
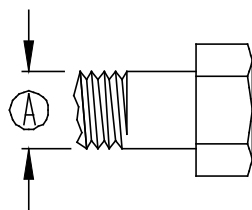

AXLE ASSEMBLY

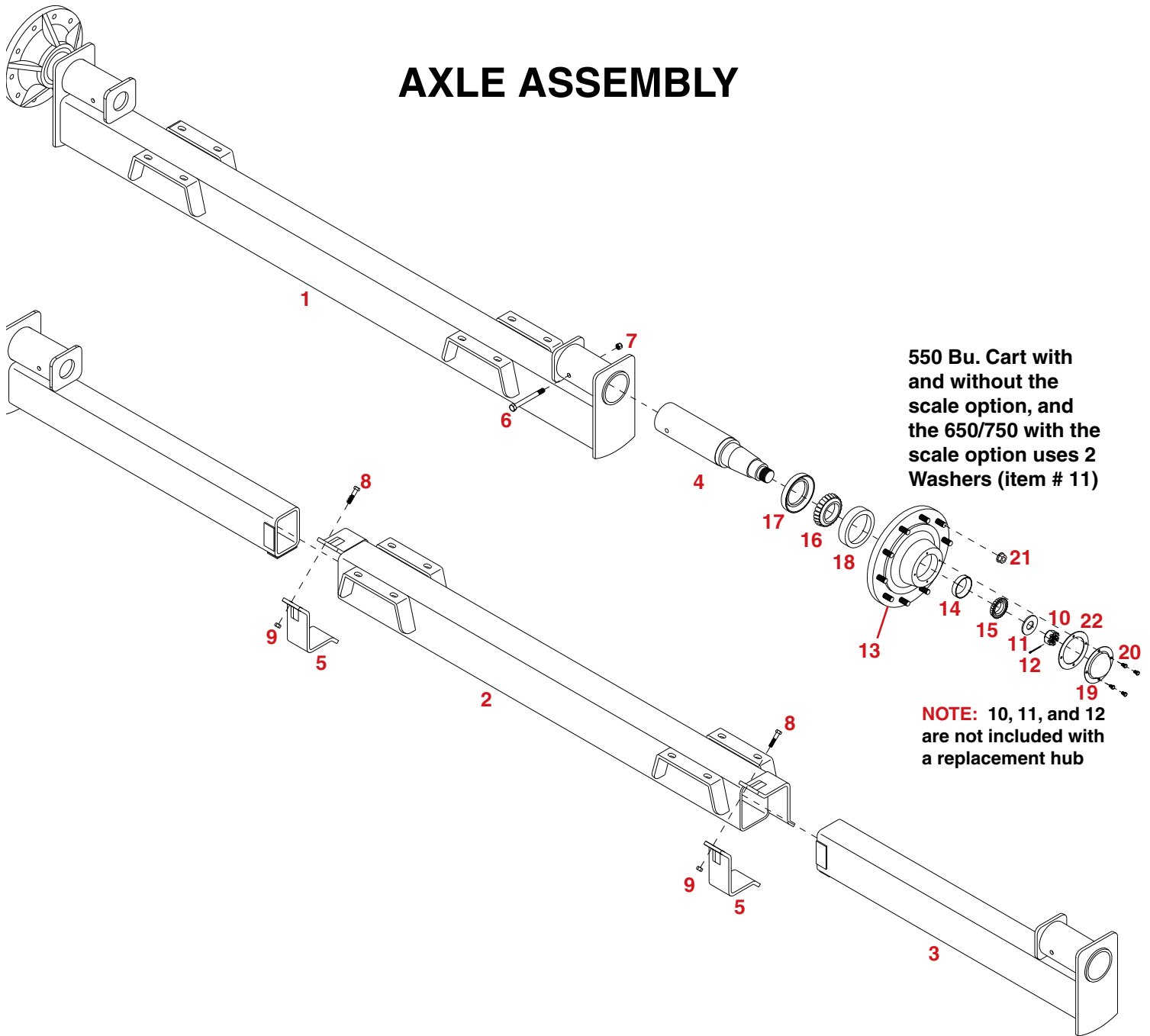

550 Bu. Cart with and without the scale option, and the 650/750 with the scale option uses 2 Washers (item # 11)

NOTE: 10, 11, and 12 are not included with a replacement hub

Ref.	Part #	QTY.	DESCRIPTION
1.	09667-30	1	Fixed 120" Axle (550 Bu.)
-	09151-30	1	Fixed 120" Axle (650 Bu.)
-	09668-30	1	Fixed 120" Axle (750 Bu.)
2.	09205-30	1	Adjustable Axle (550-650 Bu.)
-	09684-30	1	Adjustable Axle (750 Bu.)
3.	09672-30	2	Axle Insert (550 Bu.)
-	09206-30	2	Axle Insert (650-750 Bu.)
4.	09051	2	Spindle (550 Bu.)
-	09204	2	Spindle (650-750 Bu.)
5.	09214-30	2	Axle Clamps
-	00943	2	5/8"-11 UNC x 5-1/2" Hex Head Bolt (550 Bu.)
-	04836	2	5/8"-11 UNC x 7" Hex Head Bolt (650-750 Bu.)
7.	02587	2	5/8-11 UNC Nylon Insert Locknut
8.	11613	8	1/2"-13 UNC x 3" Hex Head Bolt (Gr. 8)
9.	02178	8	1/2"-13 Nylon Insert Locknut
10.	09173	2	1-1/4"-12 UNF Slotted Hex Nut (550)
-	09445	2	2"-12 UNF Castle Nut (650-750)
11.	07354	2	1-5/16" ID x 3" OD x 3/16" Washer (550)
-	09444	2	2-1/16" ID x 4" OD x 1/4" Washer (650-750)
12.	05088	2	1/4" x 2" Cotter Pin (550)
-	09446	2	3/8" x 3" Cotter Pin (650-750)
13.	07861	-	Replacement Stud bolt (550-750)

	5573	2	550 Bu. Hub Assembly (Includes items14-20)
14.	07360	1	Outer Bearing Race
15.	07358	1	Outer Bearing
16.	09054	1	Inner Bearing
17.	09055	1	Inner Grease Seal
18.	09053	1	Inner Bearing Race
19.	07362	1	Dust Cap
20.	04305	4	5/16-18 UNC x 1/2" Hex Head Bolt (Gr.5)
21.	07435	20	3/4"-16 UNF Lug Nut
22.	09532	1	Hub Cap Gasket

	5540	2	650-750 Bu. Hub Assembly(Includes items14-20)
14.	09448	1	Outer Bearing Race
15.	09450	1	Outer Bearing
16.	09449	1	Inner Bearing
17.	09452	1	Inner Grease Seal
18.	09447	1	Inner Bearing Race
19.	09451	1	Dust Cap
20.	04305	4	5/16-18 UNC x 1/2" Hex Head Bolt (Gr.5)
21.	07435	20	3/4"-16 UNF Lug Nut
22.	09532	1	Hub Cap Gasket

Please order replacement parts by PART NO. and DESCRIPTION.

AUGER ASSEMBLY

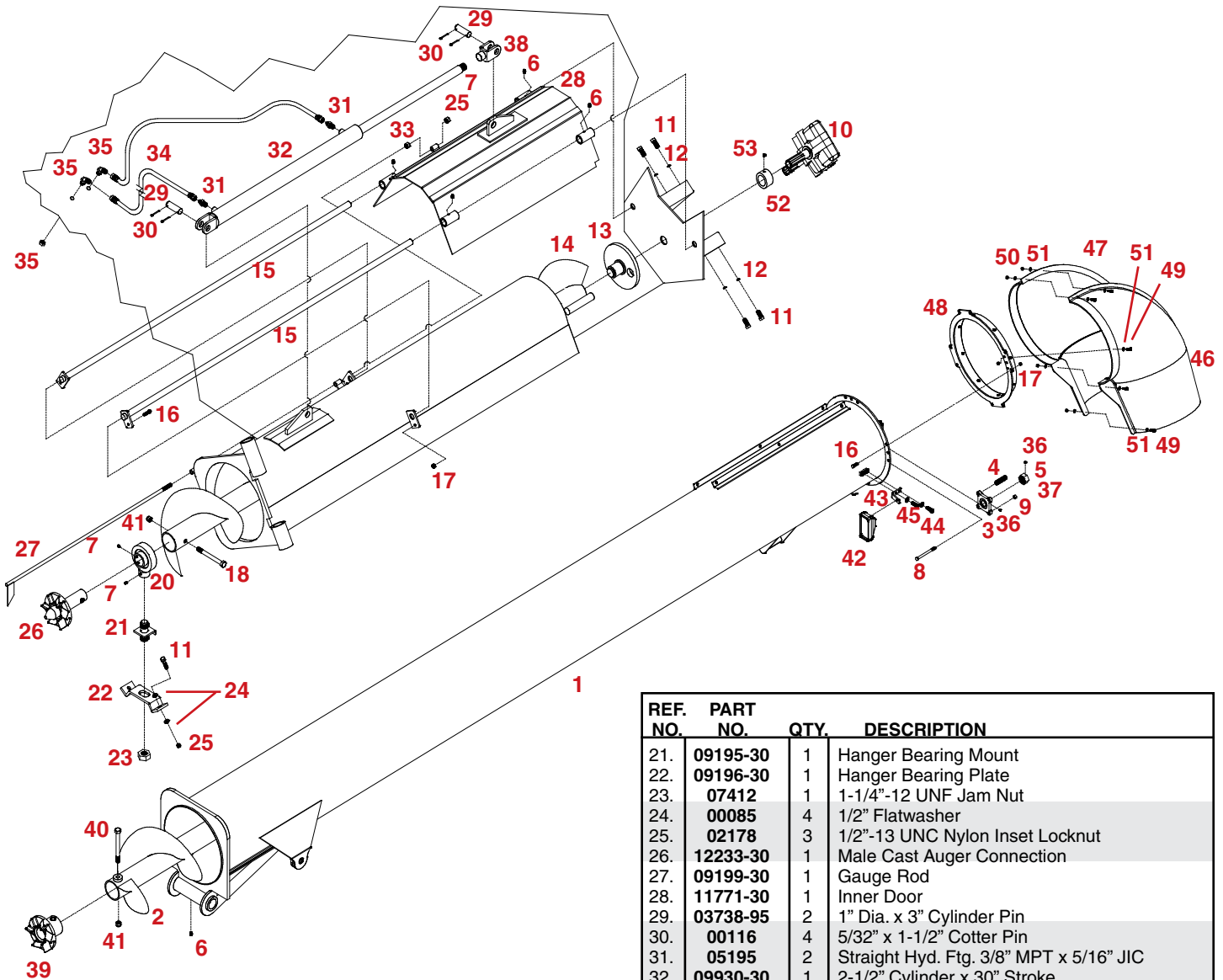

REF. NO.	PART NO.	QTY.	DESCRIPTION
1.	12663-?	1	Outer Auger Tube
2.	12565-30	1	14" Outer Auger Assembly
3.	09382	1	Flange Bearing
4.	09168	4	Upper Auger Spring
5.	11986	1	1-1/4"-12 UNF Hex Nut
6.	04642	5	1/4" Self Tapping Grease Zerk
7.	00789	6	3/8"-16 UNC x 3/8" Socket Head Set Screw
8.	09436	4	7/16"-14 UNC x 4-1/2" hex Head Bolt
9.	02771	4	7/16"-14 Nylon Insert Locknut
10.	07924	1	Gear Box
11.	01254	10	1/2"-13 UNC x 1-1/2" Hex Head Bolt (Gr.5)
12.	00084	8	1/2" Lockwasher
13.	09193-30	1	Lower Drive
14.	12567-30	1	Lower Auger
15.	09203	2	Slide Rod
16.	00523	2	3/8"-16 UNC x 1-1/4" Hex Head Bolt (Gr.5)
17.	02592	2	3/8"-16 Nylon Insert Locknut
18.	11099	1	3/4"-10 UNC x 5" Hex Head Bolt (Gr. 8)
20.	09185	1	2" Hanger Bearing

REF. NO.	PART NO.	QTY.	DESCRIPTION
21.	09195-30	1	Hanger Bearing Mount
22.	09196-30	1	Hanger Bearing Plate
23.	07412	1	1-1/4"-12 UNF Jam Nut
24.	00085	4	1/2" Flatwasher
25.	02178	3	1/2"-13 UNC Nylon Inset Locknut
26.	12233-30	1	Male Cast Auger Connection
27.	09199-30	1	Gauge Rod
28.	11771-30	1	Inner Door
29.	03738-95	2	1" Dia. x 3" Cylinder Pin
30.	00116	4	5/32" x 1-1/2" Cotter Pin
31.	05195	2	Straight Hyd. Ftg. 3/8" MPT x 5/16" JIC
32.	09930-30	1	2-1/2" Cylinder x 30" Stroke
-	5584	-	Hydraulic Cylinder Seal Repair Kit (not shown)
33.	00640	1	1/2"-13 UNC Hex Head Jam Nut
34.	05191	2	36" Hydraulic Hose
35.	09172	2	3/8" JIC Bulkhead Ftg. 45° Elbow W/Nut
36.	01923	2	1/4"-20 UNC X 1/4" Socket Head Set Screw
37.	05089	N/A	1 1/4" Machine Washer NR
38.	09741-30	1	Adjustable Cylinder End
39.	12188	1	Female Cast Auger Connection
40.	10525	1	3/4"-10UNC x 6" Hex Head Bolt (Gr.8)
41.	02961	2	3/4"-10UNC Nylon Insert Locknut
42.	09437	1	Discharge Light
43.	12555-30	1	Light Bracket
44.	01899	2	3/8"-16 UNC x 3/4" Hex Head Bolt (Gr. 5)
45.	00060	2	3/8" Lockwasher
46.	12526	1	Discharge Chute, Left
47.	12527	1	Discharge Chute, Right
48.	12679-30	1	Discharge Chute Drive Ring
49.	02990	24	5/16" UNC x 1" Hex Head Bolt (Gr. 5)
50.	02802	24	5/16" UNC Nylon Insert Locknut
51.	00004	38	5/16" Flat Washer
52.	13640-95	1	Gearbox Collar
53.	00789	1	3/8" x 3/8" Set Screw

Please order replacement parts by **PART NO.** and **DESCRIPTION**. Painted Parts are available in Red or Green. Add -10 behind the part number for red, -20 behind the part number for green, and -42 behind the part number for blue.

ADJUSTABLE DISCHARGE OPTION

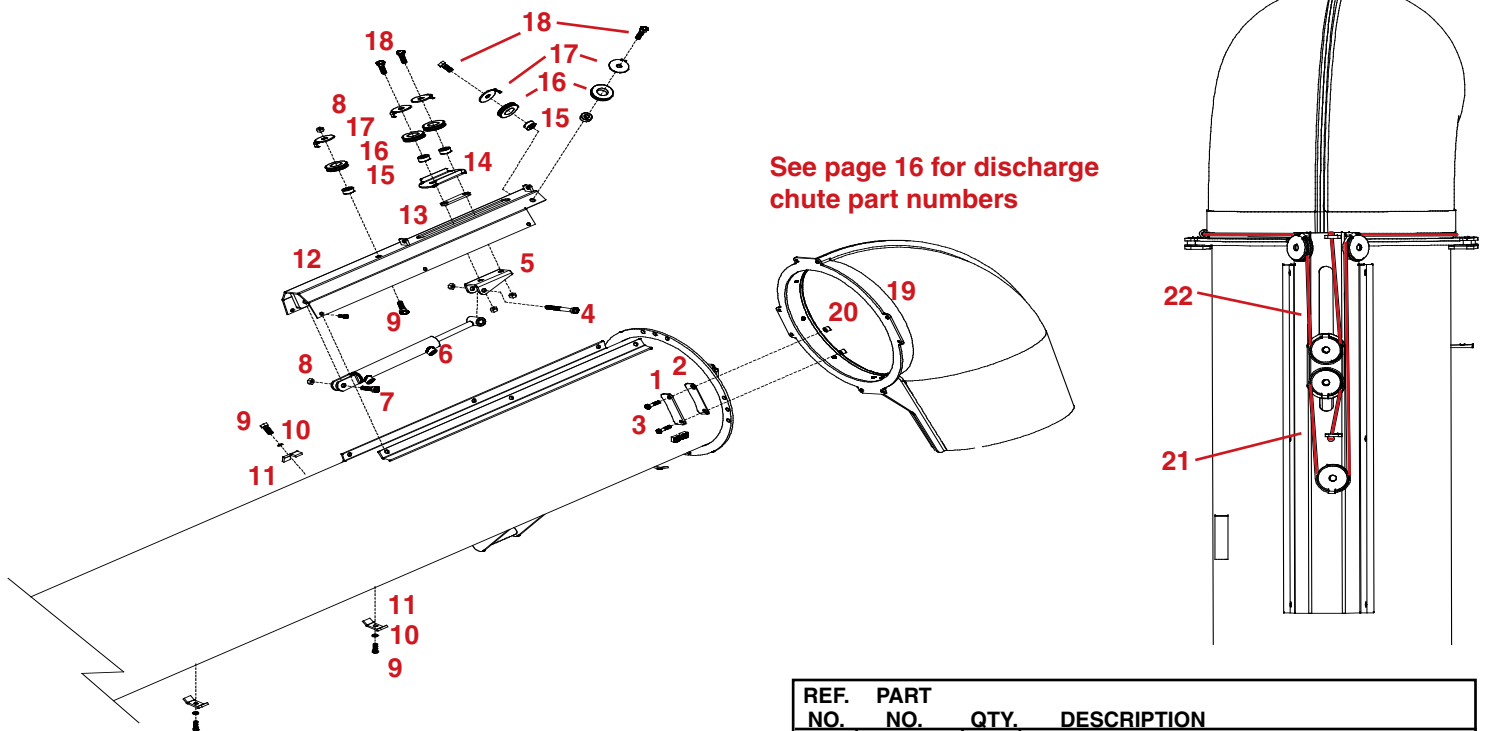

See page 16 for discharge chute part numbers

REF. NO.	PART NO.	QTY.	DESCRIPTION
1.	12549-30	4	Ring Retainer Bracket
2.	12550	4	Ring Retainer Bracket Spacer
3.	00914	8	3/8" UNC x 1 1/2" Hex Head Bolt (Gr. 5)
4.	05290	1	1/2" UNC x 3 1/4" Hex Head Bolt (Gr. 5)
5.	12513-30	1	Trolley Bottom
6.	12522-30	1	Hydraulic Cylinder
7.	00482	1	1/2" UNC x 1 3/4" Hex Head Bolt (Gr. 5)
8.	02178	7	1/2" UNC Nylon Insert Locknut
9.	01899	13	3/8" UNC x 3/4" Hex Head Bolt (Gr. 5)

REF. NO.	PART NO.	QTY.	DESCRIPTION
10.	00060	7	3/8" Lockwasher
11.	09218-95	7	2 Place Hose Keeper
12.	12684-30	1	Hydraulic Cylinder Mount
13.	12514-95	1	Trolley Spacer
14.	12512-30	1	Trolley Top
15.	09283	5	Bushing
16.	09282	5	Plastic Sheave
17.	12531-95	5	Cable Retainer Washer
18.	01253	2	1/2" UNC x 2" Hex Head Bolt (Gr. 5)
19.	02592	8	3/8" UNC Nylon Insert Locknut
20.	12551-95	8	Retainer Bracket Bushing
21.	12691	1	Long Cable
22.	12692	1	Short Cable

Please order replacement parts by PART NO. and DESCRIPTION.

GEARBOX BREAKDOWN

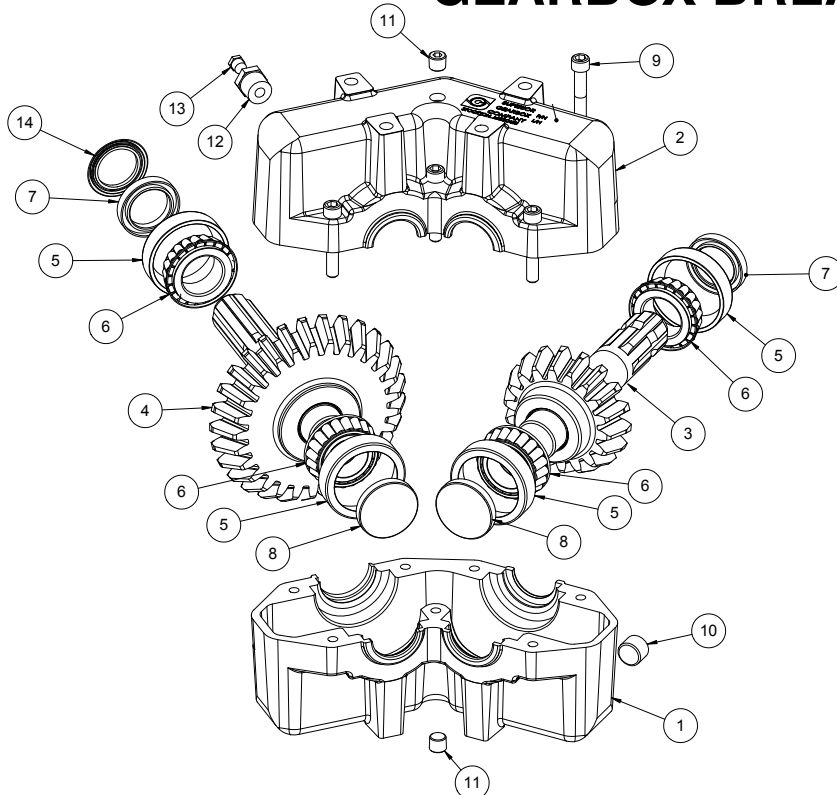

REF. NO.	PART NO.	DESCRIPTION
5.	13966	Race
6.	13967	Bearing
7.	13972	Seal
8.	13971	Seal, End Cap
10.	13973	Plug, 1/2"
11.	13974	Plug, 1/4"
13.	13975	Plug, 1/8", Vent

DEMCO Replacement Parts for Gearbox # 07924

Please order replacement parts by PART NO. and DESCRIPTION.

GRAIN CART PARTS BREAKDOWN

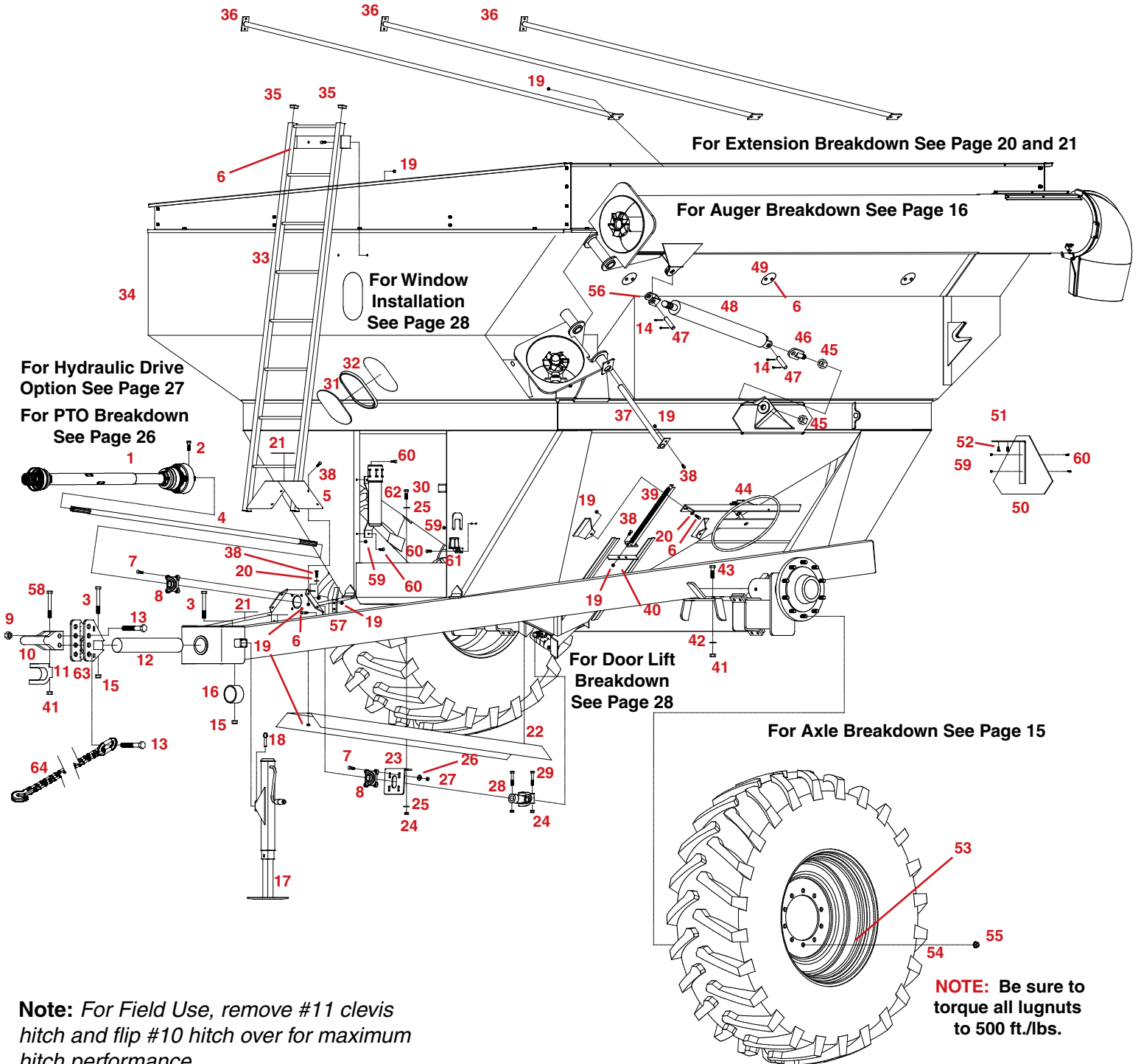

Note: For Field Use, remove #11 clevis hitch and flip #10 hitch over for maximum hitch performance.

GRAIN CART ASSEMBLY AND OPERATION

REF. NO.	PART NO.	QTY.	DESCRIPTION
1.	13399	1	PTO Shaft (1.375-21 Spline)
-	13398	1	PTO Shaft (1.75"-20 Spline)
2.	13522	1	Tapered Lock Pin, Replacement only
3.	11698	2	7/8"-9 NC x 5 1/2" Hex Head Bolt (Gr. 8)
4.	13400	1	PTO Drive Shaft
5.	09159-30	1	PTO Shaft Guard/Step
6.	00523	17	3/8"-16 UNC x 1-1/4" Hex Head Bolt (Gr.5)
7.	01254	8	1/2"-13 UNC x 1-1/2" Bolt (Gr.5)
8.	10633	2	Flange Bearing (35 mm, 4 bolt)
9.	09455	3	1"-14 UNF Stover Lock Nut
10.	09163-30	1	Category IV forged Hitch Base
11.	09164-30	1	1-1/4" Clevis Insert
12.	12404	1	Hitch Shaft
13.	09454	3	1"-14 UNF x 6-1/2" Hex Head Bolt (gr.8)
14.	00116	4	5/32" x 1-1/2" Cotter Pin
15.	10678	2	7/8"-9 NC Nylon Insert Locknut
16.	09157	1	Pinle Ring Mount Pivot Collar
17.	09219-30	1	Jack
18.	05328	1	1/2" x 3" Ball Lock Pin
19.	02592	27	3/8-16 UNC Nylon Insert Locknut
20.	00059	11	3/8" Flatwasher
21.	09499	6	Anti-skid Tape
22.	09160-30	1	Guard Plate
23.	13466-30	1	Rear Bearing Mount
24.	02178	3	1/2"-13 UNC Nylon Insert Locknut
25.	00085	4	1/2" Flatwasher
26.	00205	4	7/16" Flatwasher
27.	02771	8	7/16"-14 UNC Nylon Insert Locknut
28.	13401	1	U-Joint (1-3/8"-6 Spline to 1-3/8"-6 Spline)
29.	04073	1	1/2"-13 x 3" Hex Head Bolt (Gr.5)
30.	01254	2	1/2"-13 x 1-1/2" Hex Head Bolt (Gr.5)
31.	07276	2	Plexiglass Viewing Window
32.	07310	2	Rubber Window Seal
33.	11995-30	1	Ladder
34.	12693	1	550 Undercarriage/Box (specify Red or Green)
-	12694	1	650 Undercarriage/Box(Specify Red or Green)
-	12695	1	750 Undercarriage/Box(Specify Red or Green)
35.	03159	2	Square Tube Cap
36.	09200-30	3	Box Cross Brace
37.	10909-30	1	Folding Pin
38.	00907	16	3/8"-16 UNC x 1" Hex Head Bolt (Gr.5)
39.	01108-30	1	Door Lift Channel
40.	09662-30	1	Lower Door
41.	02961	9	3/4"-10 UNC Nylon Insert Locknut
42.	00492	8	3/4" Flat Washer
43.	05047	8	3/4"-10 UNC x 2-1/2" Hex Head Bolt (Gr.5)
44.	5693-30	1	Door Lift Assembly
45.	07412	2	1-1/4"-12 UNF Jam Nut
46.	09198-30	1	Folding Cylinder Mount
47.	03738-95	2	Cylinder Pin
48.	09930-30	1	2-1/2" Hydraulic Cylinder
-	5584	-	Hydraulic Cylinder Seal Repair Kit (not shown)
49.	01106-30	6	Box Washer
50.	12126	1	SMV Sign
51.	12468-30	1	SMV Sign Bracket
52.	07594	2	3/8" x 1" Self Tapping Bolts
53.	09380-56	2	32" x 21" Rim (650/750)
-	09381-56	2	32" x 27" Rim (650/750)
-	09174-56	2	26" x 20" Rim (550)
-	09175-56	2	32" x 21" Rim (550)
54.	T24.5L	2	24.5" x 32" x 12 Ply Tire
-	T30.5D	2	30.5" x 32" x 12 Ply Tire
55.	07435	20	3/4"-16 UNF Lug Nut
56.	09741-30	1	Adjustable Cylinder End
57.	11519-30	2	Ladder Mount Peg (black)
58.	10525	1	3/4" x 6" Gr. 8 Hex Head Bolt
59.	02772	6	1/4" Nylon Insert Locknut
60.	01076	6	1/4" x 3/4" Hex Head Bolt
61.	10277	1	Electrical Plug Holder
62.	10241	1	Operator Manual Canister
63.	12403-30	1	Hitch Receiver Channel
64.	12154	1	Safety Chain



WARNING: BE CERTAIN ALL POWER IS OFF WHEN CONNECTING PTO OR HYDRAULIC LINES TO TRACTOR

- Connect Grain Cart to tractor using a good quality hitch pin. Attach a safety chain. See Safety Manual.
- Attach power take-off shaft to tractor. Check tractor drawbar and adjust to allow clearance.
- Raise jack stand and place to rear storage position.
- Make sure no debris is in the grain cart.
- Attach hydraulic lines to tractor.
- Connect lighting hook-up to tractor.

LOADING AND UNLOADING GRAIN

- With the gate indicator in the closed position, fill the box with grain.
- With the PTO disengaged, extend auger.
- Start PTO at a **slow rate of speed** until the upper and lower drives are engaged.
- Increase PTO speed and open the inner gate halfway. When grain begins to flow, open gate to full position.
- Once grain stops flowing, return gate to closed position.
- Disengage PTO and allow it to come to a complete stop. Auger is now ready to fold to stored position. **DO NOT PULL THE GRAIN CART UNLESS THE AUGER IS IN THE STORED POSITION.**
- Never exceed 1,000 RPM on the system.
- Never fold or extend auger unless PTO is completely stopped.
- Never fill grain cart unless inner gate is closed.
- Never engage auger when system is moving at a high rate of speed.
- Never do maintenance work or service cart while the tractor is running.

Please order replacement parts by PART NO. and DESCRIPTION. Painted Parts are available in Red, Green or Blue. Add -10 behind the part number for red, -20 behind the part number for green, and -42 behind the part number for blue.

650 BUSHEL EXTENSION ASSEMBLY

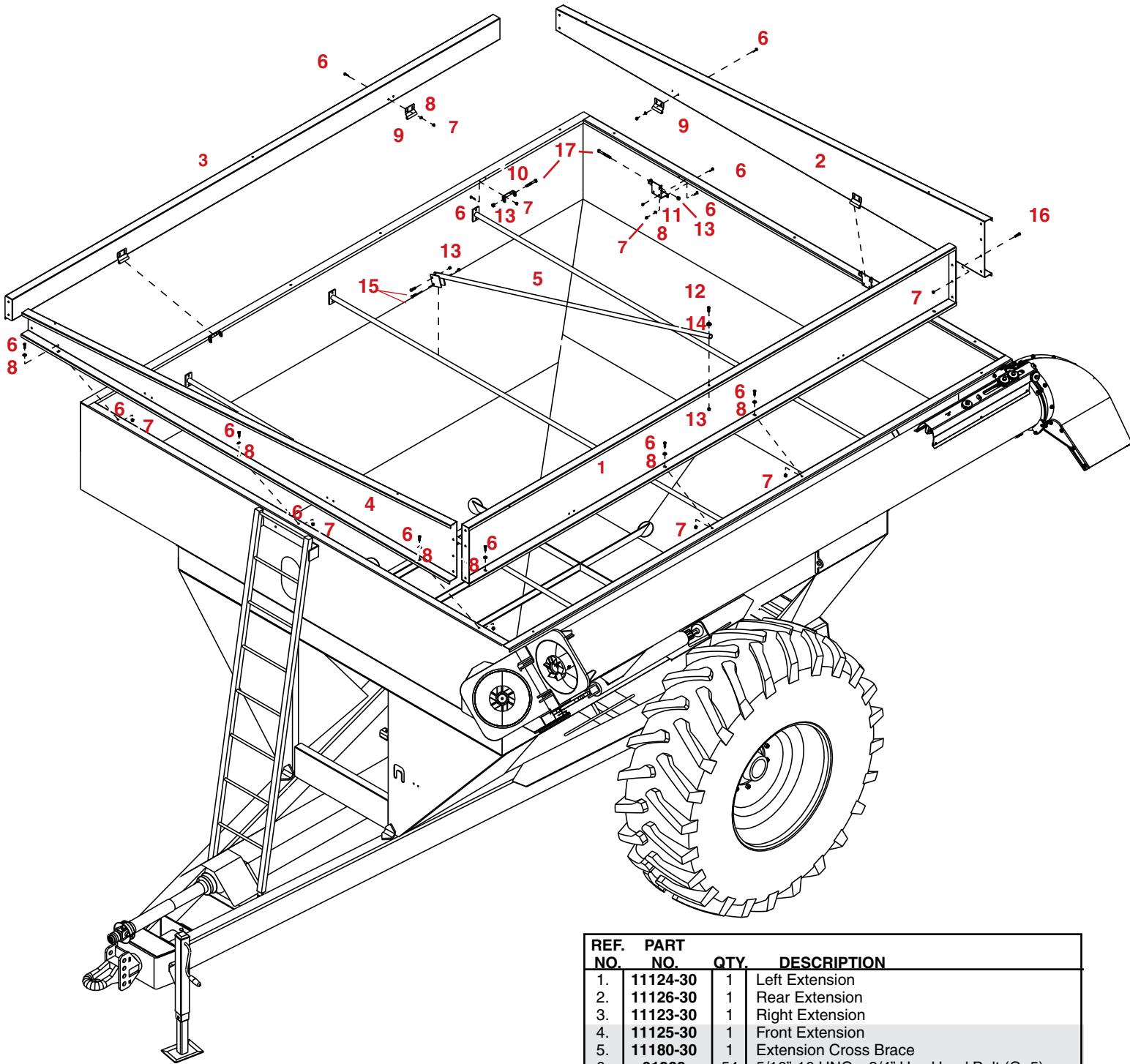

REF. NO.	PART NO.	QTY.	DESCRIPTION
1.	11124-30	1	Left Extension
2.	11126-30	1	Rear Extension
3.	11123-30	1	Right Extension
4.	11125-30	1	Front Extension
5.	11180-30	1	Extension Cross Brace
6.	01263	54	5/16"-16 UNC x 3/4" Hex Head Bolt (Gr.5)
7.	02802	66	5/16"-16 UNC Nylon Insert Locknut
8.	00004	38	5/16" Flat Washer
9.	13154-30	8	Extension Hinge Middle
10.	13153-30	4	Extension Hinge Side
11.	13152-30	4	Extension Hinge Front/Rear
12.	13052	1	3/8" UNC X 1.25 Slotted Truss Head Bolt
13.	02592	11	3/8" -16 UNC Nylon Insert Locknut
14.	00059	1	3/8" Flatwasher
15.	04226	2	3/8" -16 UNC x 2" Hex Head Bolt (Gr. 5)
16.	02990	12	5/16" -16 UNC X 1" Hex Head Bolt (Gr. 5)
17.	02769	8	3/8" x 4" Hex Head Bolt (Gr. 5)

Please order replacement parts by PART NO. and DESCRIPTION.

750 BUSHEL EXTENSION ASSEMBLY

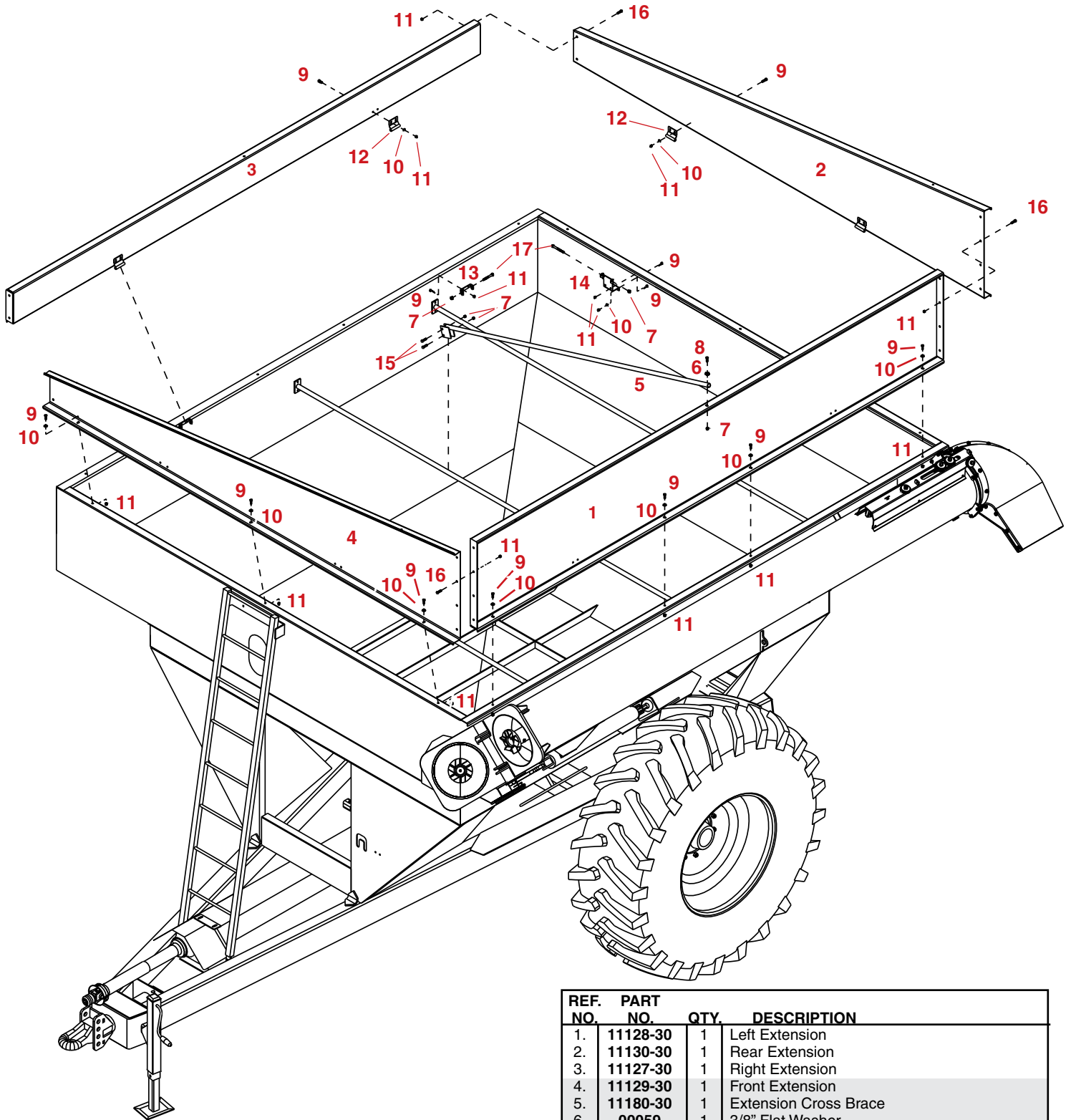

REF. NO.	PART NO.	QTY.	DESCRIPTION
1.	11128-30	1	Left Extension
2.	11130-30	1	Rear Extension
3.	11127-30	1	Right Extension
4.	11129-30	1	Front Extension
5.	11180-30	1	Extension Cross Brace
6.	00059	1	3/8" Flat Washer
7.	02592	11	3/8"-16 UNC Nylon Insert Locknut
8.	13052	1	3/8" UNC X 1.25 Slotted Truss Head Bolt
9.	01263	54	5/16"-16 UNC x 3/4" Hex Head Bolt (Gr. 5)
10.	00004	38	5/16" Flatwasher
11.	02802	66	5/16"-16 UNC Nylon Insert Locknut
12.	13154-30	8	Extension Hinge Middle
13.	13153-30	4	Extension Hinge Side
14.	13152-30	4	Extension Hinge Front/Rear
15.	04226	2	3/8" -16 UNC x 2" Hex Head Bolt (Gr. 5)
16.	02990	12	5/16"-16 UNC X 1" Hex Head Bolt (Gr. 5)
17.	02769	8	3/8" X 4" Hex Head Bolt (Gr. 5)

Please order replacement parts by PART NO. and DESCRIPTION.

HYDRAULICS PARTS AND ASSEMBLY

(Shown with optional Adjustable Hydraulic Discharge Chute)

For Optional Pendant/ Hydraulic Block Schematic, See Page 23

Item #8 is on opposite side of fittings inside box

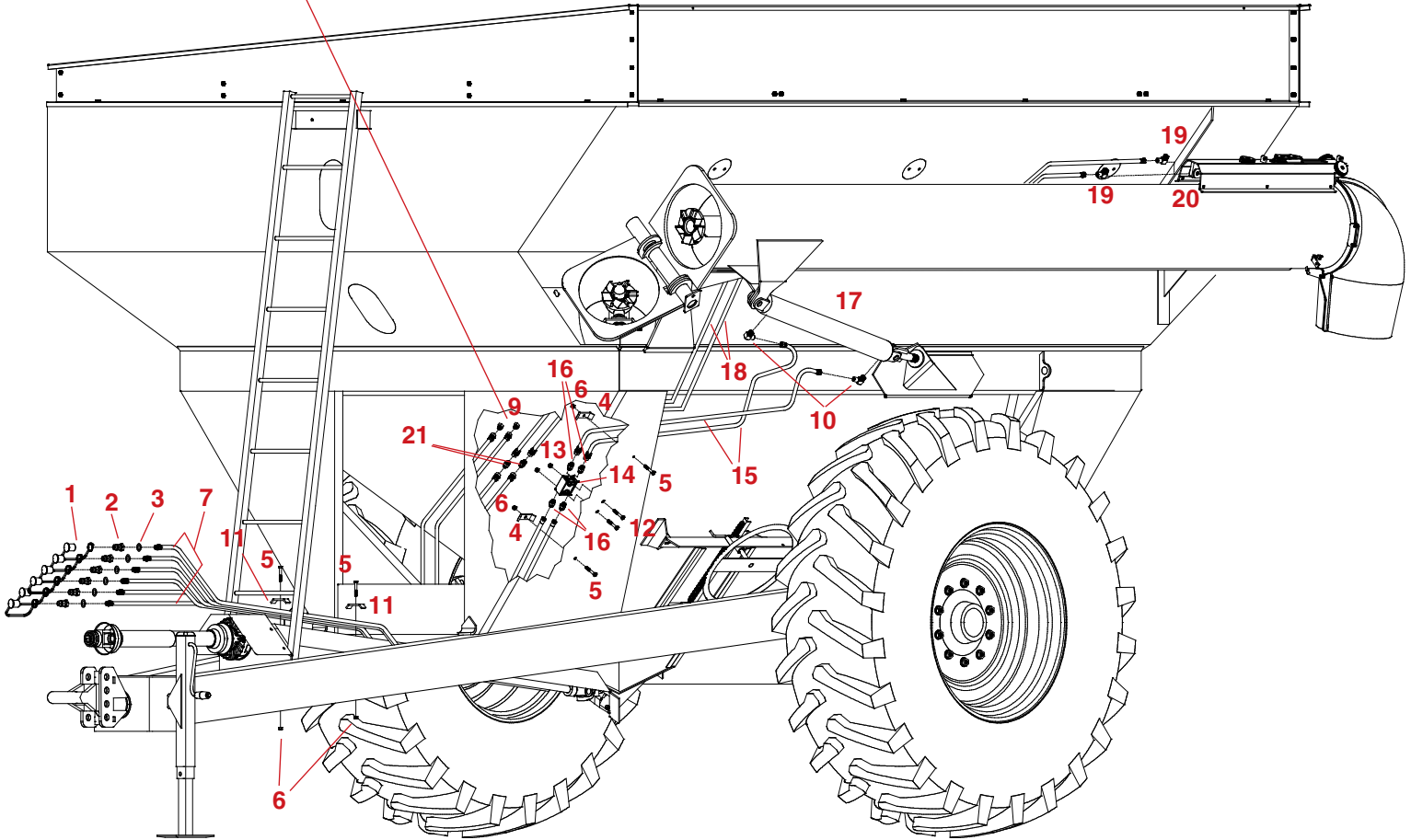

REF. NO.	PART NO.	QTY.	DESCRIPTION
1.	05198	2	Rubber Coupler Cover (Black)
-	12677	2	Rubber Coupler Cover (Red)
-	12678	2	Rubber Coupler Cover (Yellow)
2.	13888	-	Replacement Hydraulic Quick Coupler
3.	13889	-	Replacement O-Ring
4.	09218-95	2	Hose Keeper (2 Hose)
5.	00914	4	3/8"-16 UNC x 1-1/2" Hex Head Bolt (Gr.5)
6.	02592	4	3/8"-16 UNC Nylon Insert Locknut
7.	13883	-	1/2" x 16' Hydraulic Hose w/ Quick Coupler
8.	05191	2	1/2" x 36" Hydraulic Hose (Not Shown)
9.	09172	2	3/8" JIC (2X) Bulkhead Fitting Elbow 90°
10.	13882	2	3/8" MPT x #6 JIC Elb Fitting w/ .041 Orifice

REF. NO.	PART NO.	QTY.	DESCRIPTION
11.	09217-30	2	Hose Keeper (4 Hose)
12.	03547	2	5/16"-18 UNC X 2-1/4" Hex Head Bolt (Gr.5)
13.	02802	2	5/16"-18 UNC Nylon Insert Locknut
14.	07582	1	Pilot Operated Check Valve
15.	05192	2	1/4" x 60" Hydraulic Hose
16.	05243	4	Str. Hyd. Fitting w/ O-Ring
17.	09930-30	1	2-1/2" Cylinder
-	5584	-	Hydraulic Cylinder Seal Repair Kit (not shown)
18.	13884	2	1/4" Hydraulic Hose, 20' long
19.	13886	2	90° Elbow, 6 O-Ring x Male 6 JIC
20.	12522-30	1	Hydraulic Cylinder
21.	09950	2	Ftg Hyd Str .563"™ (2X) Union

Please order replacement parts by PART NO. and DESCRIPTION.

OPTIONAL PENDANT CONTROL HYDRAULIC SCHEMATIC

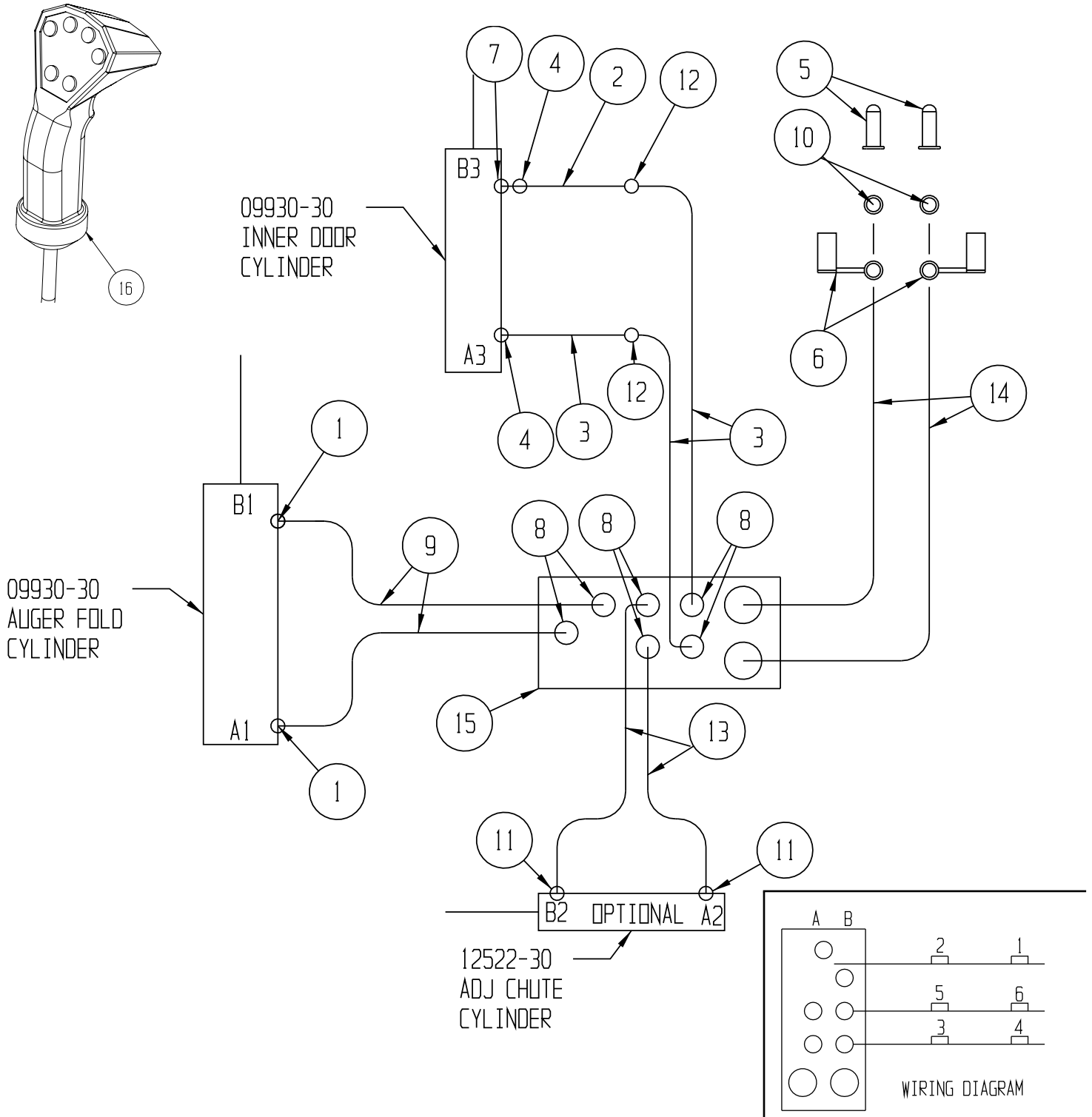

REF. NO.	PART NO.	QTY.	DESCRIPTION
1.	13882	2	3/8" MPT x #6 JIC Elbow W/ .041 Orifice
2.	05190	1	1/4" x 48" Hydraulic Hose
3.	05191	3	1/4" x 36" Hydraulic Hose
4.	05195	2	Str. Hyd. Fitting, .375 MPT
5.	13890	2	Replacement Hydraulic Quick Coupler
6.	05198	2	Rubber Coupler Cover (Black)
7.	05215	1	3/8" MPT x 3/8" FPT Elbow Fitting
8.	05243	6	Str. Hyd. Fitting w/ O-Ring
9.	05840	2	1/4" x 84" Hydraulic Hose

REF. NO.	PART NO.	QTY.	DESCRIPTION
10.	13891	2	Replacement O-Ring
11.	13886	2	90° Elbow Hyd. Fitting w/ O-Ring
12.	12374	2	Bulkhead Hydraulic Fitting, 45°
13.	13884	2	1/4" x 420" Hydraulic Hose
14.	13885	2	1/2" x 16' Hydraulic Hose
15.	13064	1	Hydraulic Block w/ wiring Harness
16.	13063	1	Pendant Controller
-	13566	-	12' Ext. Pendant Controller Cable (Optional)

Please order replacement parts by PART NO. and DESCRIPTION.

LIGHTING PARTS AND ASSEMBLY

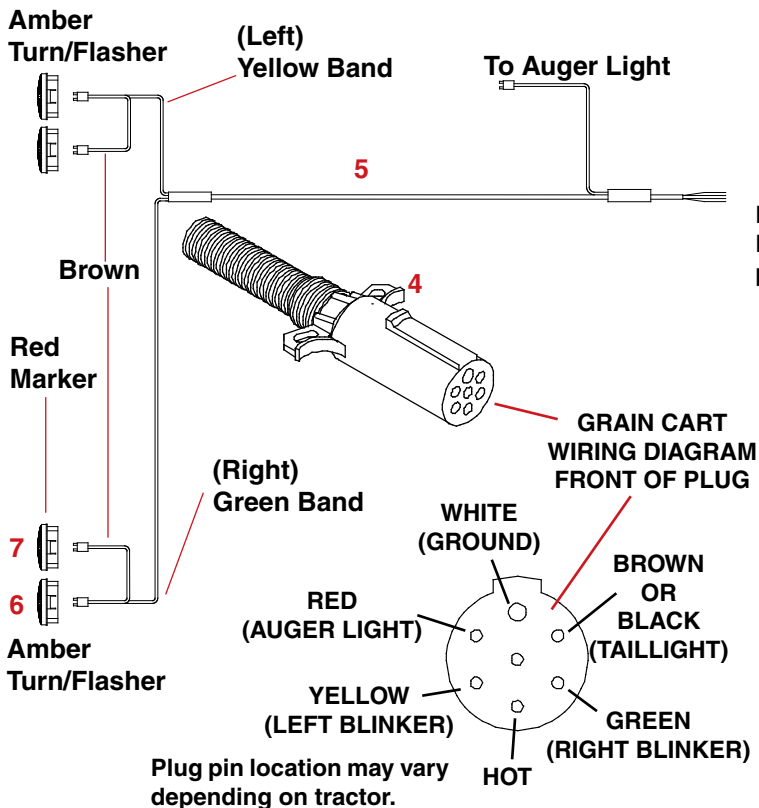
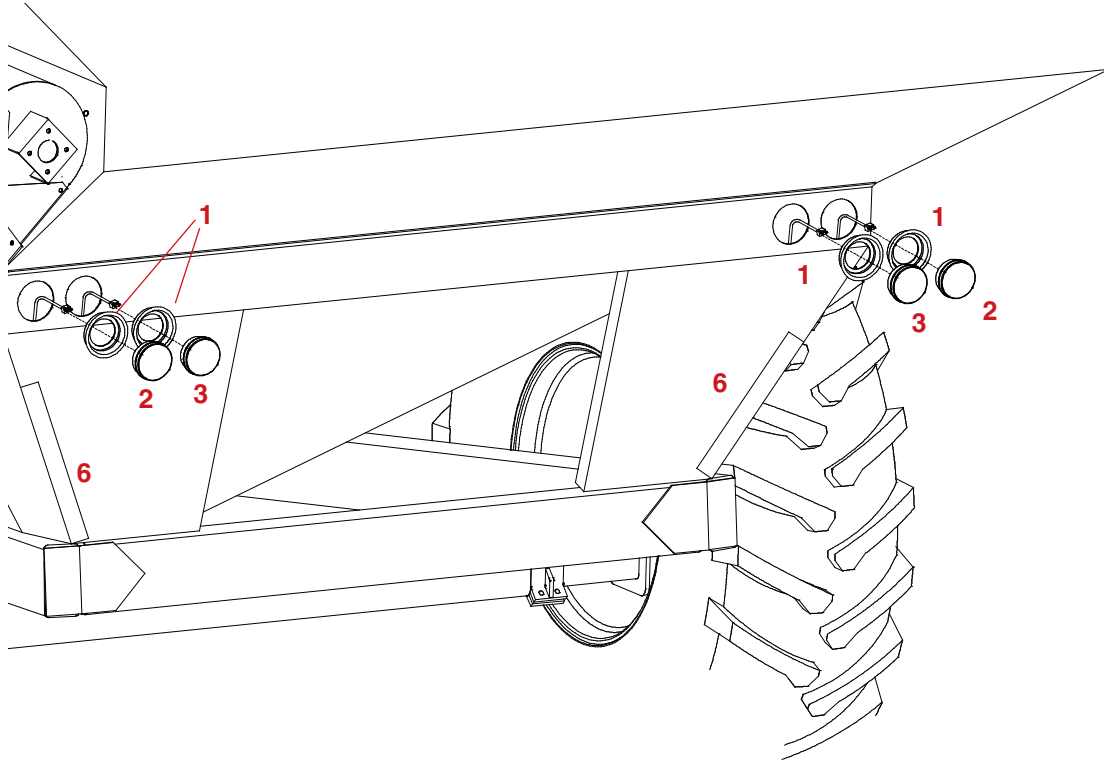

REF. NO.	PART NO.	QTY.	DESCRIPTION
1.	05447	4	4" Light Grommet
2.	05260	2	4" Amber Light
3.	05446	2	4" Red Light
4.	07416	1	7-Way Male Plug Connector
5.	09149	1	Wiring Harness
6.	07278	2	Conspicuity Tape

Please order replacement parts by PART NO. and DESCRIPTION. Painted Parts are available in Red or Green. Add -10 behind the part number for red and -20 behind the part number for green.

INSTALLING THE LIGHT KIT

1. Begin by inserting a Light Mounting Grommet (#1) into each mounting hole. After connecting the wire harness to the lights as shown in the schematic, press Red Light (#3) and Amber Light (#2) until they are securely mounted in the grommets.
2. Proceed wiring the lights as shown in the drawing and the wiring schematic.
3. When connecting the wire harness (#5) to the front (male tractor) plug (#4) follow the wire schematic as follows: Brown wire to the Red braking marker lights, Yellow wire to the left turning marker light, Green wire to the right turning marker light, and White wire to the ground. Proceed wiring the lights as shown in the drawing and the wiring schematic.

NOTE : Connect the wires to the tractor plug in, make sure all lights are in correct working order. When working correctly behind a tractor the amber lights are the flashing warning lights, and the turn signals.

SCALE OPTION PARTS BREAKDOWN

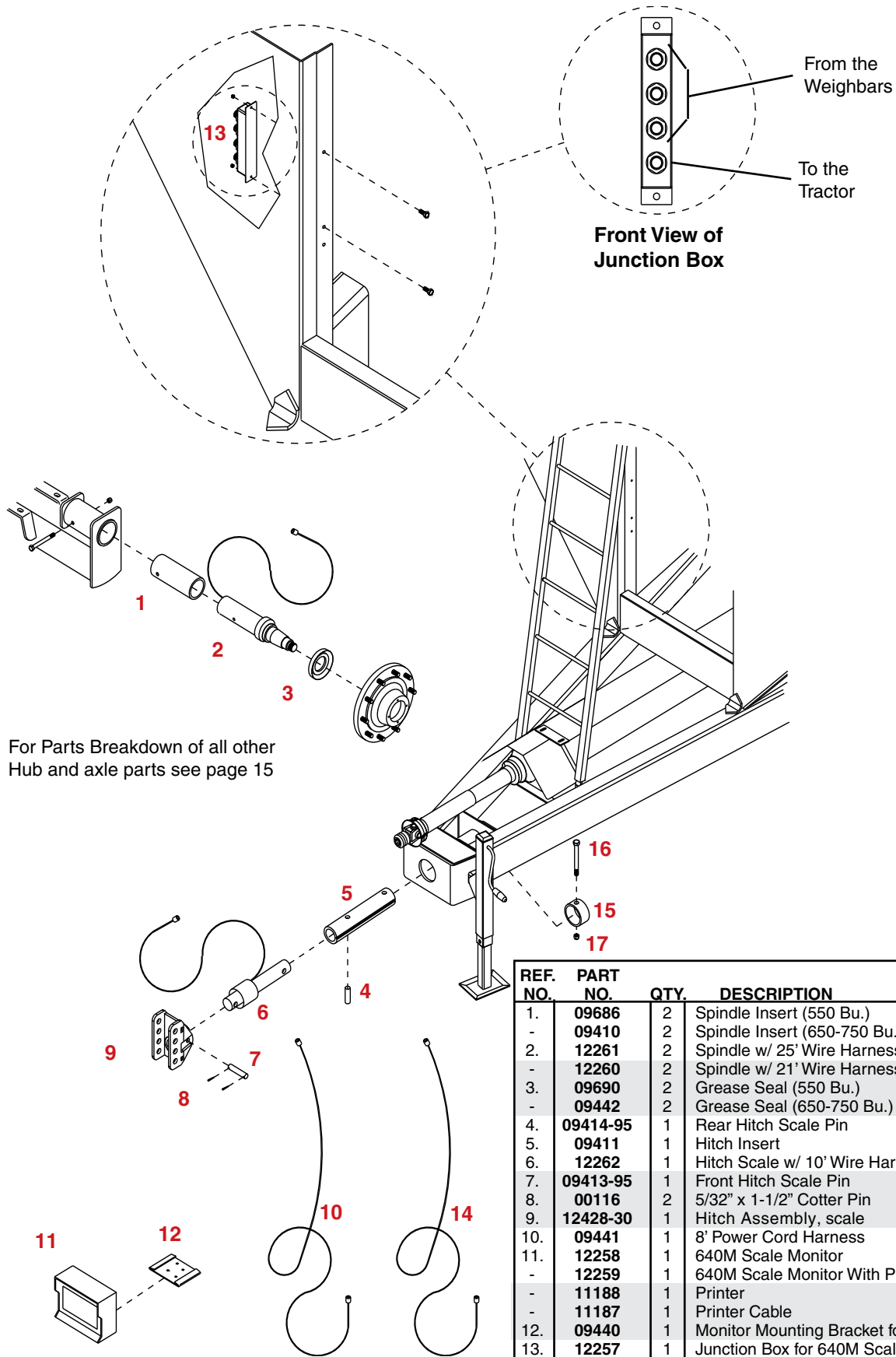

For Parts Breakdown of all other Hub and axle parts see page 15

REF. NO.	PART NO.	QTY.	DESCRIPTION
1.	09686	2	Spindle Insert (550 Bu.)
-	09410	2	Spindle Insert (650-750 Bu.)
2.	12261	2	Spindle w/ 25' Wire Harness (550 Bu.)
-	12260	2	Spindle w/ 21' Wire Harness (650-750 Bu.)
3.	09690	2	Grease Seal (550 Bu.)
-	09442	2	Grease Seal (650-750 Bu.)
4.	09414-95	1	Rear Hitch Scale Pin
5.	09411	1	Hitch Insert
6.	12262	1	Hitch Scale w/ 10' Wire Harness
7.	09413-95	1	Front Hitch Scale Pin
8.	00116	2	5/32" x 1-1/2" Cotter Pin
9.	12428-30	1	Hitch Assembly, scale
10.	09441	1	8' Power Cord Harness
11.	12258	1	640M Scale Monitor
-	12259	1	640M Scale Monitor With Printer Port
-	11188	1	Printer
-	11187	1	Printer Cable
12.	09440	1	Monitor Mounting Bracket for 640M
13.	12257	1	Junction Box for 640M Scale Unit
14.	12264	1	25' Wire Harness (Junction Box to Console)
15.	09157-30	1	Hitch Mount Pivot Collar
16.	11698	1	7/8"-9 NC x 5 1/2" Hex Head Bolt (Gr. 8)
17.	10678	1	7/8"-9 NC Nylon Insert Locknut

Please order replacement parts by PART NO. and DESCRIPTION.

PTO DRIVE SHAFT PARTS BREAKDOWN

Check the PTO overlap length. Try to obtain the greatest possible overlap without bottoming out the PTO shaft in its maximum operating condition. Make sure draw bar length and PTO telescoping limits are adequate for uneven terrain, gullies, levees, etc.

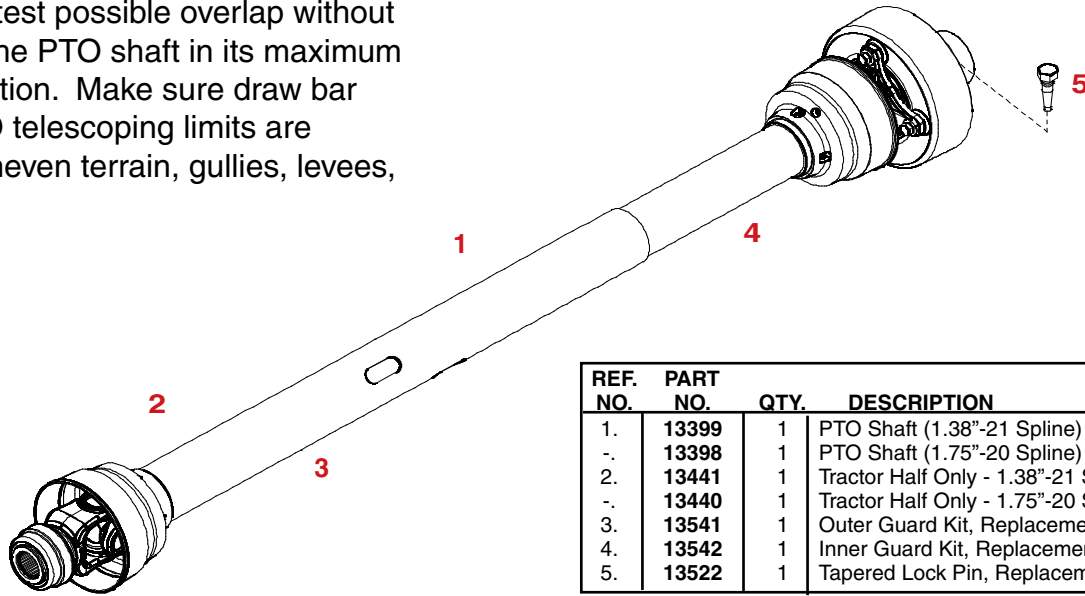

REF. NO.	PART NO.	QTY.	DESCRIPTION
1.	13399	1	PTO Shaft (1.38"-21 Spline) Complete
-	13398	1	PTO Shaft (1.75"-20 Spline) Complete
2.	13441	1	Tractor Half Only - 1.38"-21 Spline
-	13440	1	Tractor Half Only - 1.75"-20 Spline
3.	13541	1	Outer Guard Kit, Replacement Only
4.	13542	1	Inner Guard Kit, Replacement Only
5.	13522	1	Tapered Lock Pin, Replacement Only

Please order replacement parts by **PART NO.** and **DESCRIPTION.**

1. Maximum Operating Length L_B

Maximum operating length should not be more than half of telescoping member length (P_U).

2. Maximum Joint Angles (B1 & C2)

Do not exceed normal operation joint angle of 25°

Ensure equal joint angles and switch off PTO if joint angles are too large and/or unequal.

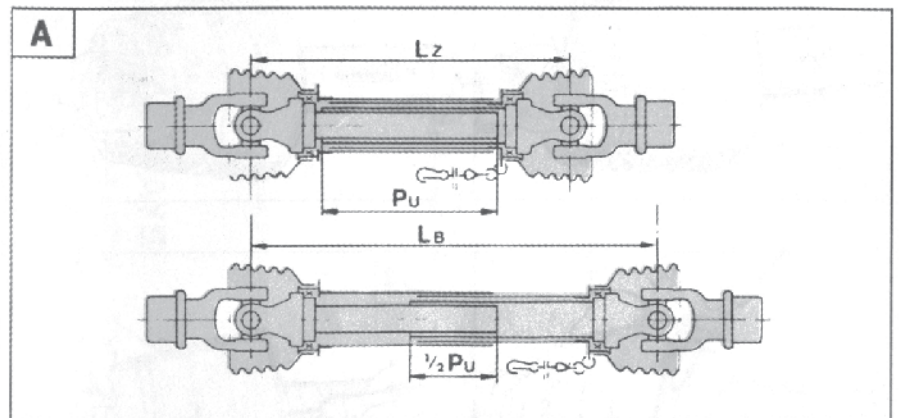

3. Lubrication

Lubricate before starting work and every 8 hours of operation.

4. Please refer the PTO Manufacture's Manual, which is located in the manual holder for further details regarding usage, service and lubrication grease locations.

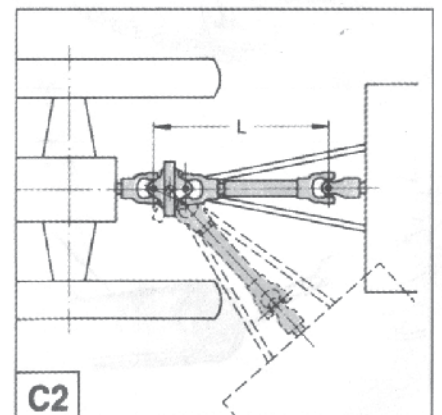
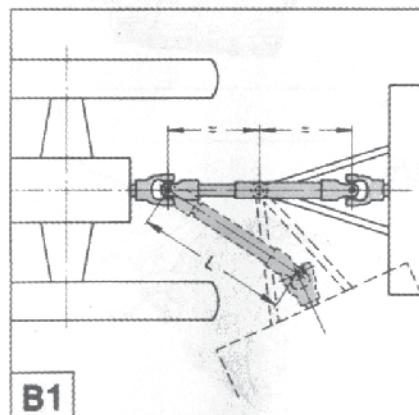

HYDRAULIC DRIVE ASSEMBLY

***NOTE:** Hydraulic motor has a capacity of 15-25 gallons per minute. For optimum motor speed, 25 GPM oil flow required.

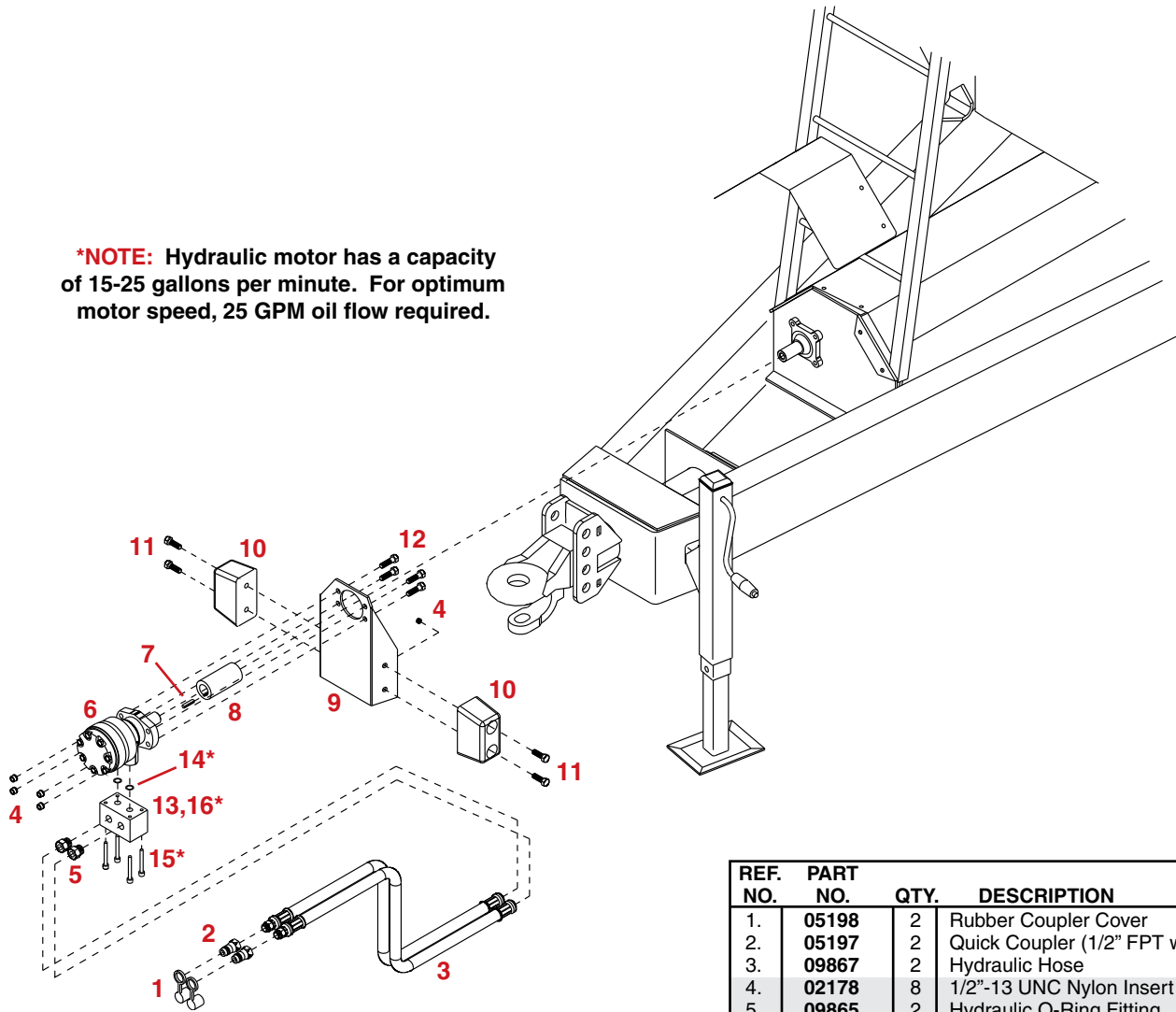

Operation

- Make sure the hydraulic motor is connected to the tractor's priority port.
- For instructions on the operation of the grain cart see page 19.

REF. NO.	PART NO.	QTY.	DESCRIPTION
1.	05198	2	Rubber Coupler Cover
2.	05197	2	Quick Coupler (1/2" FPT with male tip)
3.	09867	2	Hydraulic Hose
4.	02178	8	1/2"-13 UNC Nylon Insert Locknut
5.	09865	2	Hydraulic O-Ring Fitting
6.	13783	1	Hydraulic Motor W/ Key
7.	09842	1	Replacement Keystick
8.	13617-30	1	Shaft Coupler w/ 1/4 x 1/4" Set Screws
9.	09841-30	1	Motor Mount Bracket
10.	03647	2	Molded Rubber Bumper
11.	05290	4	1/2"-13 UNC x 3-1/4" Bolt Gr.5)
12.	01253	4	1/2"-13 UNC x 2-0" Bolt (Gr.5)
13.	13784	1	Hydraulic Motor Mount Block (Includes *)
14*.	13794	-	Replacement O-Ring
15*.	13793	-	Replacement Cap Screw 2-3/4"
16*.	13792	-	Check Valve

Please order replacement parts by PART NO. and DESCRIPTION.

WINDOW INSTALLATION

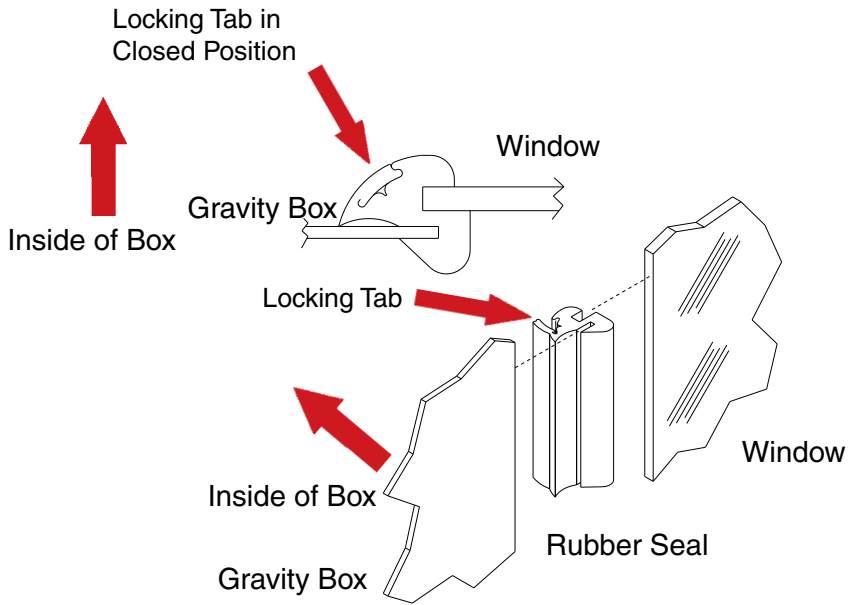

INSTALLATION PROCEDURE

The installation must be done from inside the box.

1. Place rubber molding in opening. Seam should begin on side of opening.
2. Remove the protective sheeting from both sides of the plastic window.
3. Slide window into groove in molding. Use a flat blade screwdriver to get molding seated correctly. Using soapy water will aid in installation
4. Using the flat blade screwdriver, press in the locking tab.

Door Lift Assembly Parts Breakdown

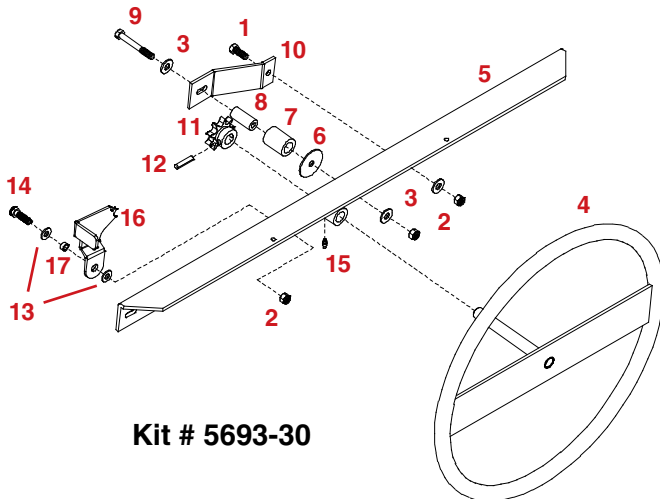

REF. NO.	PART NO.	QTY.	DESCRIPTION
	5693-30		Door Lift Assembly
1.	00907	1	3/8"-16 UNC x 1" Hex Head Bolt (Gr.5)
2.	02592	3	3/8"-16 UNC Nylon Insert Locknut
3.	00059	3	3/8" Flat Washer
4.	01112-30	1	Door Lift Wheel
5.	11415-30	1	Door Lift Wheel Mount
6.	01113	1	2" O.D. x 3/8" I.D. Washer
7.	05364	1	1-1/4" O.D. 3/4" I.D. Bushing
8.	05363	1	3/4" O.D. x 3/8" I.D. Bushing
9.	02207	1	3/8"-16 UNC x 3" Hex Head Bolt (Gr.5)
10.	01243-30	1	Roller Blade Bracket
11.	01332	1	9 Tooth Sprocket
12.	02849	1	5/16" x 1-3/8" Roll Pin
13.	00004	2	5/16" Flatwasher
14.	00523	1	3/8-16UNC x 1 1/4" Hex Head Bolt (Gr. 5)
15.	04642	1	1/4" Grease Zerk
16.	11412-30	1	Latch
17.	11414	1	Latch Bushing

Please order replacement parts by PART NO. and DESCRIPTION.

GREASE & LUBE

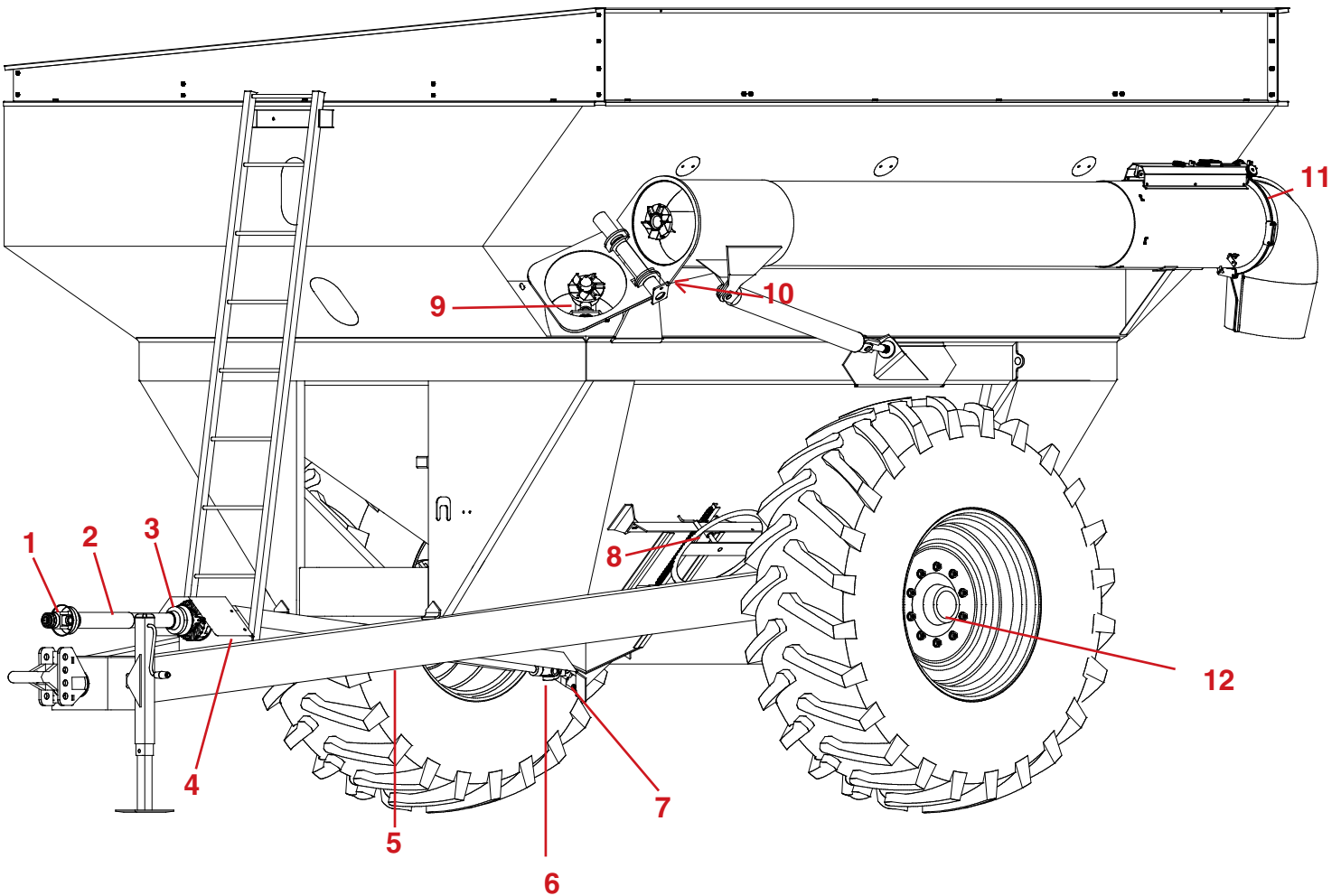

Reference numbers **#1 -#3 -#6** Are U-Joints -- Check and grease regularly.

Reference number **#2** - Is a Telescoping P.T.O. Shaft with two slots in housing -- Fully extend P.T.O. Shaft, then place one or two pumps of grease in each slot.

Reference numbers **#4 -#5** Are fixed self centering sealed bearings -- Do not over grease sealed bearings.

Reference number **#7** - Auger gear box is filled with 80-90 gear lube -- To check gear box find inspection allen plug. Turn out plug gear lube should just start to run out. If low fill until gear lube just starts to run out . **DO NOT OVER FILL!!!** When gear box is full be sure to replace inspection plug.

Reference number **#8** - Is a bushing for the turn handle of the door lift assembly -- Inspect and grease as needed.

Reference numbers **#9 - #11** - Are fixed sealed bearing -- Do not over grease sealed bearings.

Reference number **#10** - Is the hinge for the outer tube. There is one zerk in this area -- Inspect and grease as needed.

Reference number **#12** - Is the axle hub with inner and outer bearings and race -- Inspect regularly, pack bearing and replace inner wheel seal as needed.

NOTE. Grease all zerks before each use or when needed with a good quality lubricant. **Do Not** over grease sealed bearings. Over greasing sealed bearing will damage seals. Once a season is generally sufficient.

INNER DOOR MAINTENANCE/ LUBE INSTRUCTIONS

REF. NO.	PART NO.	QTY.	DESCRIPTION
1.	04642	4	1/4" Self Tapping Grease Zerk
2.	11771-30	1	Inner Door
3.	09203	2	Slide Rod

Please order replacement parts by PART NO. and DESCRIPTION.

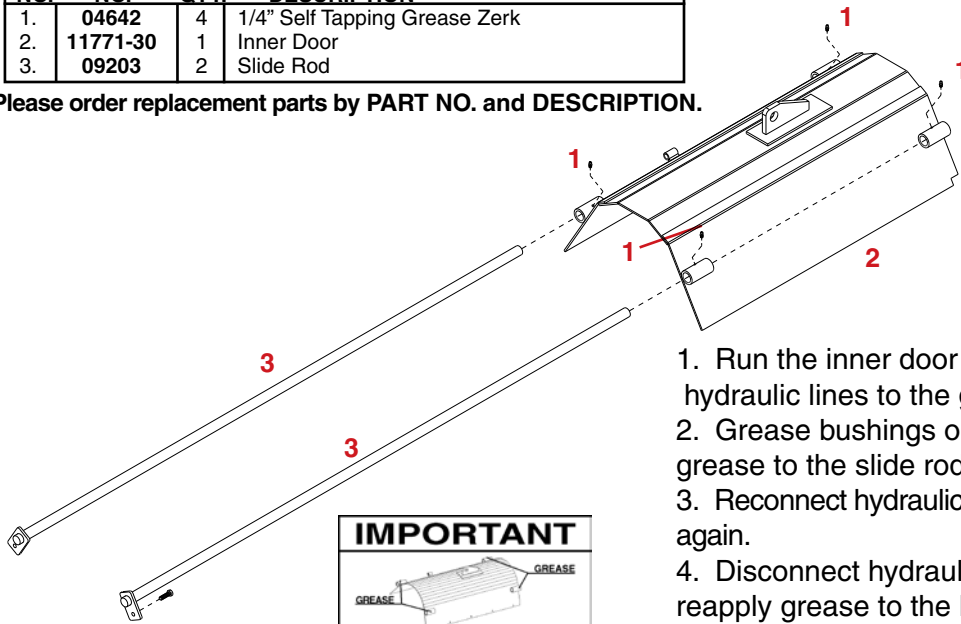

Decal AG21100 is located on the front of the grain cart

1. Run the inner door (#2) fully open and disconnect hydraulic lines to the grain cart.
2. Grease bushings on door and apply a generous coat of grease to the slide rods (#3).
3. Reconnect hydraulics and run door closed and open again.
4. Disconnect hydraulic lines to the grain cart again and reapply grease to the bushings and slide rails.
5. Reconnect hydraulics and run the door closed and open five times. Check to make sure slide rails are fully coated with grease and door operated smoothly.
6. Check and grease the zerks and slide rails **EVERY 20 HOURS AND/OR ANNUALLY**.
7. Make sure slide rails have a generous coating of grease before and after long periods of storage. Always store cart with inner door fully open and follow maintenance procedures listed on pages 26 and 27 of the manual.

To insure proper operation of inner door, these steps must be followed and proper maintenance must be performed.

LUBE INSTRUCTIONS FOR GEAR BOX

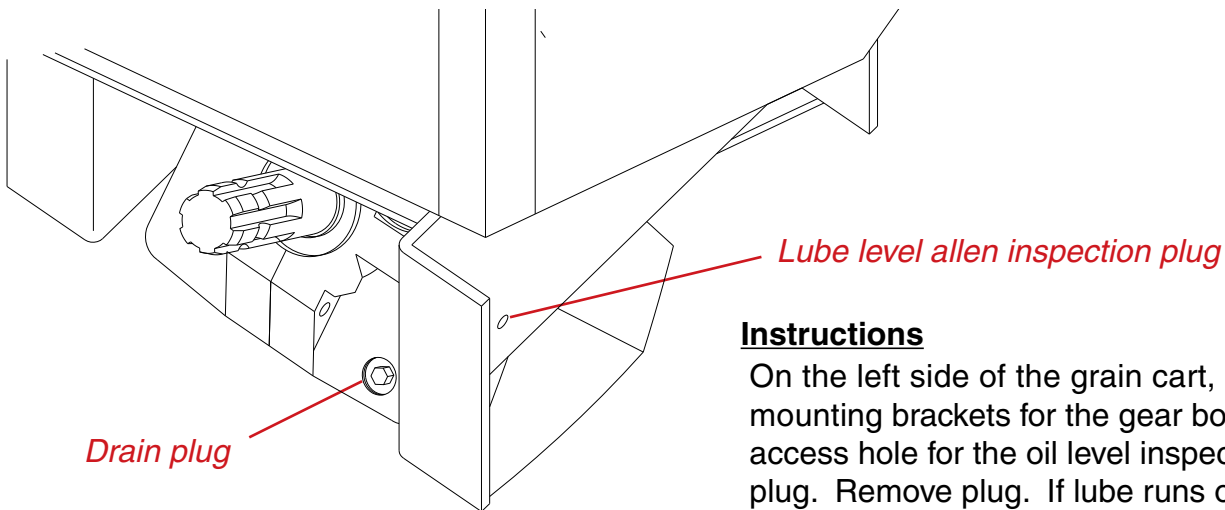

Note: Inspection of lube level must be performed on a hard, level surface with both tires inflated to the proper pressure and the tongue as level as possible.

Instructions

On the left side of the grain cart, locate the mounting brackets for the gear box. There is an access hole for the oil level inspection ALLEN plug. Remove plug. If lube runs out of the hole, the level is sufficient. If lube does not run out, there is a matching hole and plug on the opposite side of the gear box for filling. Fill with a standard 80/90 gear lube until lube just starts to run out of inspection hole.

GRAIN CART CHECKLIST:

Downtime in the fields caused by field breakdowns is costly and time consuming. Many breakdowns can be eliminated by periodic equipment maintenance. By spending a little time running over this checklist, following proper after-season care, you can save time and money later on.



WARNING: To Prevent Serious Injury Or Death

- Make sure ALL guards and shields are in place.
- Keep hands, feet, and loose clothing away from rotating parts.

Before Going To The Field :

1. HYDRAULIC HOSES

- Check all hoses for worn or soft spots.
- Check to make sure hoses are not kinked or pinched.
- Check for leakage in any of the lines and cylinders.

2. REPLACEMENT PARTS

- Replace all worn or damaged parts.

3. VISUALLY INSPECT

- Inspect tires for cracks and worn spots.
- Inspect inside of Grain Cart, make sure that all guards are in place and in good shape. Be sure auger is free from any obstructions.
- Inspect for any loose bolts, worn parts, or cracked welds, and make any necessary repairs.

4. CHECK

- Tires for proper inflation.
- Lug nuts for proper torque.
- Lights for proper operation.
- Oil level in gearbox.
- Zerk locations, and grease as needed.
- All guards and shields. Replace or repair if necessary to insure proper protection.

After Season Care:

Open inner slide gate and outer door to allow box to drain.

Keep auger folded back during storage.

Grease all zerk locations.

Repack wheel bearings before storage.

Inspect tires for puncture, holes or any other type of leak and repair as needed.

Tire Inflation Chart

GRAIN CART APPLICATION	TIRE SIZE	PLY	MAXIMUM TIRE PSI.
550 Diamond Tire	23.1 x 26	12	32 psi.
550 Bushel Lug Tire	24.5 x 32	12	32 psi.
550 Bushel Diamond Tire	24.5 x 32	12	32 psi.
650-750 Bushel Lug Tire	24.5 x 32	12	32 psi.
650-750 Bushel Diamond Tire	24.5 x 32	12	32 psi.
650-750 Bushel Lug Tire	30.5 x 32	12	26 psi.
650-750 Bushel Diamond Tire	30.5 x 32	12	26 psi.
Duals 650-750 Lug Tire	18.4 x 38	8	26 psi.



P.O. BOX 189
4010 320th St., BOYDEN, IA. 51234
PH: (712) 725-2311
FAX: (712) 725-2380
TOLL FREE: 1-800-54DEMCO (1-800-543-3626)
www.demco-products.com