

Demco

DFBII

45' & 60' Flotation Boom

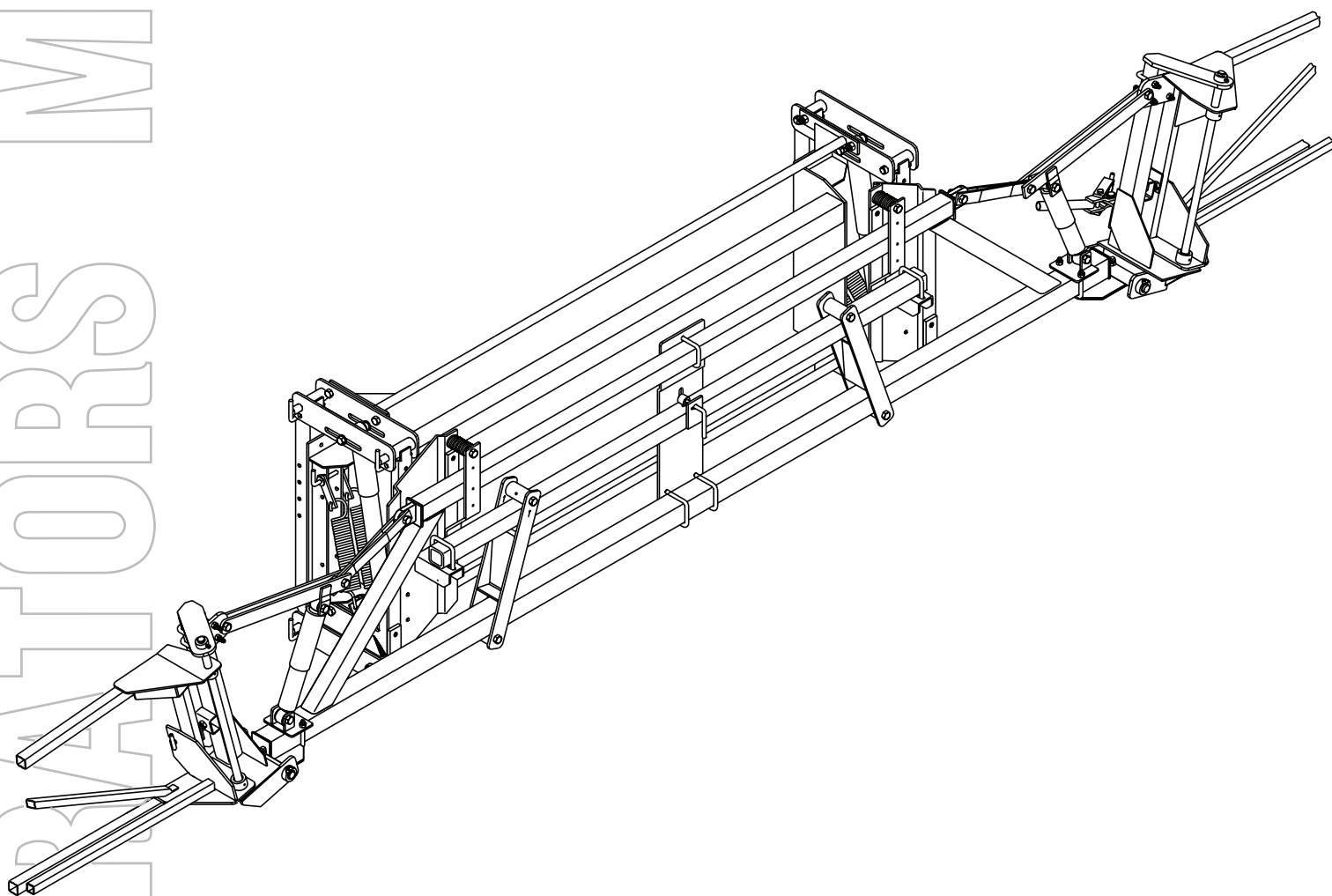

ASSEMBLY
CALIBRATION
OPERATION
REPLACEMENT PARTS

READ *complete manual CAREFULLY
BEFORE attempting operation.*

Doing Our Best to Provide You the Best

MANUAL
OPERATORS

WARRANTY POLICY & REGISTRATION

Go online to www.demco-products.com to review Demco warranty policies and register your Demco product.

Thank you for purchasing a Demco sprayer. We feel you have made a wise choice and hope you are completely satisfied with your new sprayer. If you have any questions regarding the applications of certain solutions or chemicals, contact your chemical supplier and follow chemical manufacturer recommendations as well as all licensing and use restrictions or regulations.



WARNING: TO AVOID PERSONAL INJURY OR PROPERTY DAMAGE, OBSERVE FOLLOWING INSTRUCTIONS:

Chemicals are dangerous. Know exactly what you're going to do and what is going to happen before attempting to work with these products. Improper selection or use can injure people, animals, plants and soil.

Always wear protective clothing such as coveralls, goggles and gloves when working with chemicals or sprayer.

Be sure to dispose of all unused chemicals or solutions in a proper and ecologically sound manner.

GENERAL INFORMATION

1. **This Manual covers all DEMCO Sprayer products. Please read complete manual.**
2. Unless otherwise specified, high-strength (grade5) (3 radial-line head markings) hex head bolts are used throughout assembly of this sprayer.
3. Whenever terms “LEFT” and “RIGHT” are used in this manual it means from a position behind sprayer and facing forward.

Table of Contents

General information -----	3
Safety , Signal Words-----	4
Remember-----	4
Equipment Safety Guidelines-----	5
Lighting and Marking-----	5
Tire Safety -----	5
Before Operation-----	5-6
During Operation-----	6-7
Following Operation-----	7
Highway and Transport Operations-----	7-8
Performing Maintenance -----	8
Safety Sign Care -----	9
Bolt Torque Specifications -----	9
DBFT Boom Carrier Assembly and Parts Breakdown-----	10
Mounting the DBFT Boom Carrier With Hydraulic Height Adjust -----	11
Center Section Parts Breakdown and Parts List-----	12
Left Inner Wing Parts Breakdown and Parts List -----	13
Right Inner Wing Parts Breakdown and Parts List -----	14
Right and Left Outer Wing Parts Breakdown and Parts List -----	15
Breakaway Hinge Update Kit -----	16
Optional Hydraulic Wing Leveling and Wheel Tip Protector-----	17
Adjustment Procedures -----	18
Adjustment and Folding Procedures-----	19
Maintenance and Lubrication -----	20
Tip Placement -----	21
Nozzle Parts Breakdown and Parts List-----	22
Sprayer Calibration -----	23
Sprayer Checklist -----	24

SAFETY

TAKE NOTE! THIS SAFETY ALERT SYMBOL FOUND THROUGHOUT THIS MANUAL IS USED TO CALL YOUR ATTENTION TO INSTRUCTIONS INVOLVING YOUR PERSONAL SAFETY AND SAFETY OF OTHERS. FAILURE TO FOLLOW THESE INSTRUCTIONS CAN RESULT IN INJURY OR DEATH.



THIS SYMBOL MEANS

ATTENTION

BECOME ALERT

YOUR SAFETY IS INVOLVED!

SIGNAL WORDS

This manual uses the following signal words--**DANGER**, **WARNING**, and **CAUTION**-- with safety messages. The appropriate signal word has been selected using the following guidelines.

WARNING:

Indicates a potentially hazardous situation that, if not avoided, could result in death or serious injury, and includes hazards that are exposed when guards are removed. It may also be used to alert against unsafe practices.

DANGER:

Indicates an imminently hazardous situation that, if not avoided, will result in death or serious injury. This signal word is to be limited to most extreme situations typically for machine components which, for functional purposes, cannot be guarded.

CAUTION:

Indicates a potentially hazardous situation that, if not avoided, may result in minor or moderate injury. It may also be used to alert against unsafe practices.

If you have questions not answered in this manual , require additional copies, or if your manual is damaged, please contact your dealer or Demco, P.O. Box 189, 4010 320th Street, Boyden, IA 51234

PH: (712) 725-2311 Toll Free 1-800-543-3626 Fax (712) 725-2380

<http://www.demco-products.com>



REMEMBER

Your best assurance against accidents is a careful and responsible operator. If there is any portion of this manual or function you do not understand, contact your local authorized dealer or manufacturer.



SAFETY...YOU CAN LIVE WITH IT



EQUIPMENT SAFETY GUIDELINES

Every year many accidents occur which could be avoided by a few seconds of thought and more careful approach to handling equipment. You, the operator, can avoid accidents by observing precautions in this section. To avoid personal injury, study precautions and insist those working with you, or you yourself, follow them.

Keep all shields in place. If shield removal becomes necessary for repairs, replace shield prior to use.

Replace any caution, warning, danger or instruction safety decal that is not readable or is missing.

Do not attempt to operate this sprayer under the influence of alcohol or drugs.

Review safety instructions with all users.

Operator should be a responsible adult. **DO NOT ALLOW PERSONS TO OPERATE OR ASSEMBLE THIS SPRAYER UNTIL THEY HAVE DEVELOPED A THOROUGH UNDERSTANDING OF SAFETY PRECAUTIONS AND HOW IT WORKS.**

To prevent injury or death, use a tractor equipped with a roll over protective system (ROPS). Do not paint over, remove, or deface any safety signs or warning decals on your sprayer. Observe all safety signs and practice instructions on them.

Never exceed limits of sprayer. If its ability to do a job, or to do so safely is in question **DON'T TRY IT.**



LIGHTING AND MARKING

It is the responsibility of operator to know lighting and marking requirements of local highway authorities and to install and maintain equipment to provide compliance with regulations. Add extra lights when transporting at night or during periods of limited visibility.

Lighting kits are available from your dealer or manufacturer.



TIRE SAFETY

- Failure to follow proper procedures when mounting tire on rim can produce an explosion resulting in serious injury or death.
- Do not attempt to mount tire unless you have proper equipment and experience.
- Inflating or servicing tires can be dangerous. Whenever possible, trained personnel should be called to service or mount tires.
- Always order and install tires and wheels with appropriate type and load capacity to meet or exceed anticipated weight to be placed on sprayer.



BEFORE OPERATION:

- Carefully study and understand this manual and the Owner's Manual.
- Do not wear loose-fitting clothing which may catch in moving parts.
- Always wear protective clothing and substantial shoes.
- It is recommended that suitable hearing and eye protection be worn.

- Operator may come in contact with certain materials which may require specific safety equipment relative to handling of such materials. (Examples: extremely dusty, molds, fungus, bulk fertilizers, etc.)
- Keep wheel and lug nuts tightened to specified torque.
- Assure that agricultural implement tires are inflated evenly.
- Give sprayer a visual inspection for any loose bolts, worn parts, or cracked welds, and make necessary repairs. Follow maintenance safety instructions included in this manual.
- Be sure there are no tools lying on or in equipment
- Do not use sprayer until you are sure that area is clear, especially around children and animals.
- Don't hurry learning process or take sprayer for granted. Ease into it and become familiar with your new equipment.
- Practice operation of your sprayer and its attachments. Completely familiarize yourself and other operators with its operation before using.
- Use a tractor equipped with Roll Over Protection System (ROPS) and fasten your seat belt prior to starting engine.
- Manufacturer does not recommend usage of tractor with ROPS removed.
- Move tractor wheels to widest recommended settings to increase stability.
- Do not allow anyone to stand between tongue or hitch and towing unit when backing up to equipment.



DURING OPERATION

- Beware of bystanders, **PARTICULARLY CHILDREN!** Always look around to make sure it is safe to start engine of towing unit or move sprayer. This is particularly important with higher noise levels and quiet cabs, as you may not hear people shouting.
- **NO PASSENGERS ALLOWED-** Do not carry passengers anywhere on or in the tractor or sprayer.
- Keep hands and clothing clear of moving parts.
- Do not clean, lubricate, or adjust your sprayer while it is moving.
- When halting operation, even periodically, set tractor or towing unit brakes, disengage PTO, shut off engine, and **remove ignition key**.
- Be especially observant of operating area and terrain- watch for holes, rocks, or other hidden hazards. Always inspect area prior to operation.
 - DO NOT operate near edge of drop-offs or banks.
 - DO NOT operate on steep slopes as overturn may result.
 - Operate up and down (not across) intermediate slopes. Avoid sudden starts and stops.
- Pick the most level possible route when transporting across fields. Avoid edges of ditches, gullies, and steep hillsides.
- Be extra careful when working on inclines.
- Periodically clear equipment of brush, twigs, or other materials to prevent buildup of dry combustible materials.
- Maneuver tractor or towing unit at safe speeds.
- Avoid overhead wires or other obstacles. Contact with overhead lines could cause serious injury or death.

- Avoid loose gravel, rocks, and holes; they can be dangerous for equipment operation or movement.
- Allow for sprayer length when making turns.
- Do not walk or work under raised components or attachments unless securely positioned and blocked.
- Keep all bystanders, pets, and livestock clear of work area.
- Operate towing unit from operators seat only.
- Never stand alongside of unit with engine running or attempt to start engine and/or operate machine while standing alongside of unit.
- Never leave running equipment attachments unattended.
- As a precaution, always recheck hardware on equipment following every 100 hours of operation. Correct all problems. Follow maintenance safety procedures.



FOLLOWING OPERATION

- Following operation, or when unhitching, stop tractor or towing unit, set brakes, disengage PTO and all power drives, shut off engine and **remove ignition key**.
- Store sprayer in an area away from human activity.
- Do not park sprayer where it will be exposed to livestock for long periods of time. Damage and livestock injury could result.
- Do not permit children to play on or around the stored sprayer.
- Make sure all parked machines are on a hard, level surface and engage all safety devices.
- Wheel chocks may be needed to prevent unit from rolling.



HIGHWAY AND TRANSPORT OPERATIONS

- **SAFETY CHAINS:** If equipment is going to be transported on a public highway, always follow state and local regulations regarding safety chains and auxiliary lighting. Be sure to check with local law enforcement agencies for your own particular regulations. If required safety chains should be obtained and installed. Only safety chains (not elastic or nylon/plastic tow straps) should be used to retain connection between towing and towed machines in event of separation of primary attaching system. Use a high strength, appropriately sized hitch pin with a mechanical retainer and attach safety chains. Criss cross chains under tongue and secure to draw bar cage, mounting loops, or bumper frame.
- Adopt safe driving practices:
 - Keep brake pedals latched together at all times. **NEVER USE INDEPENDENT BRAKING WITH SPRAYER IN TOW. LOSS OF CONTROL OR UPSET MAY RESULT.**
 - Always drive at a safe speed relative to local conditions and ensure that your speed is low enough for an emergency stop. Keep speed to a minimum.
 - Reduce speed prior to turns to avoid risk of overturning.
 - Always keep tractor or towing unit in gear to provide engine braking when going downhill. Do not coast.
 - Do not drink and drive!
- Comply with state and local laws governing highway safety and movement of farm machinery on public roads.
- Use approved accessory lighting flags and necessary warning devices to protect operators of other vehicles on highway during transport. Various safety lights and devices are available from your dealer.
- Use of flashing amber lights is acceptable in most localities. However, some localities prohibit their use. Local laws should be checked for all highway lighting and marking requirements.

- When driving tractor and sprayer under 20 mph (40 kph) day or night, use flashing amber warning lights and a slow moving vehicle (SMV) identification emblem.
- Plan your route to avoid heavy traffic.
- Be a safe and courteous driver. Always yield to oncoming traffic in all situations, including narrow bridges, intersections, etc.
- Be observant of bridge load ratings. Do not cross bridges rated lower than gross weight of unit you are operating.
- Watch for obstructions overhead and side to side while transporting.
- Always operate equipment in a position to provide maximum visibility at all times. Make allowances for increased length and weight of sprayer when making turns, or stopping.



PERFORMING MAINTENANCE

- Good maintenance is your responsibility. Poor maintenance is an invitation to trouble.
- Make sure there is plenty of ventilation. Never operate engine of towing vehicle in a closed building. Exhaust fumes may cause asphyxiation.
- Before working on this machine, stop towing vehicle, set brakes, disengage PTO and all power drives, shut off engine and **remove ignition key**.
- Be certain all moving parts and attachments have come to a complete stop before attempting to perform maintenance.
- Always use a safety support and block wheels. Never use a jack to support machine.
- Always use proper tools or equipment for job at hand.
- Use extreme caution when making adjustments.
- Follow torque chart in owners manual when tightening bolts and nuts.
- Never use your hands to locate a hydraulic leak on attachments. Use a small piece of cardboard or wood. Hydraulic fluid escaping under pressure can penetrate skin.
- Openings in skin and minor cuts are susceptible to infection from hydraulic fluid. **Without immediate medical treatment, serious infection and reactions can occur.**
- When disconnecting hydraulic lines, shut off hydraulic supply and relieve all hydraulic pressure.
- Replace **all shields** and **guards** after servicing and before moving.
- After servicing, be sure all tools, parts and service equipment are removed.
- Do not allow grease or oil to build up on any steps or platform.
- When replacing bolts refer to owners manual.
- Refer to bolt torque chart in owners manual for head identification marking.
- Where replacement parts are necessary for periodic maintenance and servicing, genuine factory replacement parts must be used to restore your equipment to original specifications. Manufacturer will not claim responsibility for use of unapproved parts or accessories and other damages as a result of their use.
- If equipment has been altered in any way from original design, manufacturer does not accept any liability for injury or warranty.
- A fire extinguisher and first aid kit should be kept readily accessible while performing maintenance on this equipment.



SAFETY SIGN CARE

- Keep safety signs clean and legible at all times.
- Replace safety signs that are missing or have become illegible.
- Replacement parts that displayed a safety sign should also display current sign.
- Safety signs are available from your distributor, dealer parts department, or manufacturer.

How to install safety signs:

- Be sure installation area is clean and dry.
- Decide on exact position before you remove backing paper.
- Remove smallest portion of split backing paper.
- Align decal over specified area and carefully press small portion with exposed sticky backing in place.
- Slowly peel back remaining paper and carefully smooth remaining portion of decal into place.
- Small air pockets can be pierced with a pin and smoothed out using piece of decal backing paper.



TORQUE SPECIFICATIONS

Torque figures indicated are valid for non-greased or non-oiled threads and heads unless otherwise specified. Therefore, do not grease or oil bolts or capscrews unless otherwise specified in this manual. When using locking elements, increase torque values by 5%.

* GRADE or CLASS value for bolts and capscrews are identified by their head markings.

Bolt Torque for Metric bolts *

"A"	CLASS 8.8		CLASS 9.8		CLASS 10.9	
	lb-ft	(N.m)	lb-ft	(N.m)	lb-ft	(N.m)
6	9	(13)	10	(14)	13	(17)
7	15	(21)	18	(24)	21	(29)
8	23	(31)	25	(34)	31	(42)
10	45	(61)	50	(68)	61	(83)
12	78	(106)	88	(118)	106	(144)
14	125	(169)	140	(189)	170	(230)
16	194	(263)	216	(293)	263	(357)
18	268	(363)	--	--	364	(493)
20	378	(513)	--	--	515	(689)
22	516	(699)	--	--	702	(952)
24	654	(886)	--	--	890	(1206)

Bolt Torque for Standard bolts *

"A"	GRADE 2		GRADE 5		GRADE 8	
	lb-ft	(N.m)	lb-ft	(N.m)	lb-ft	(N.m)
1/4"	6	(8)	9	(12)	12	(16)
5/16"	10	(13)	18	(25)	25	(35)
3/8"	20	(27)	30	(40)	45	(60)
7/16"	30	(40)	50	(70)	80	(110)
1/2"	45	(60)	75	(100)	115	(155)
9/16"	70	(95)	115	(155)	165	(220)
5/8"	95	(130)	150	(200)	225	(300)
3/4"	165	(225)	290	(390)	400	(540)
7/8"	170	(230)	420	(570)	650	(880)
1"	225	(300)	630	(850)	970	(1310)

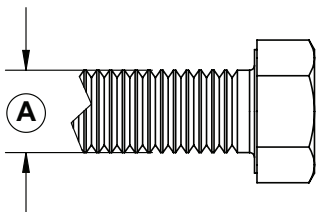

GRADE-2

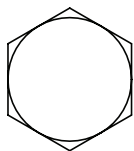

GRADE-5

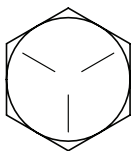

GRADE-8

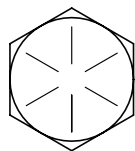

CLASS 8.8

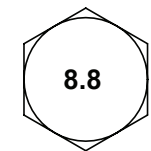

CLASS 9.8

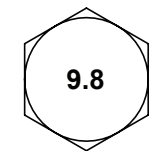

CLASS 10.9



DBFT BOOM CARRIER ASSEMBLY AND PARTS BREAKDOWN

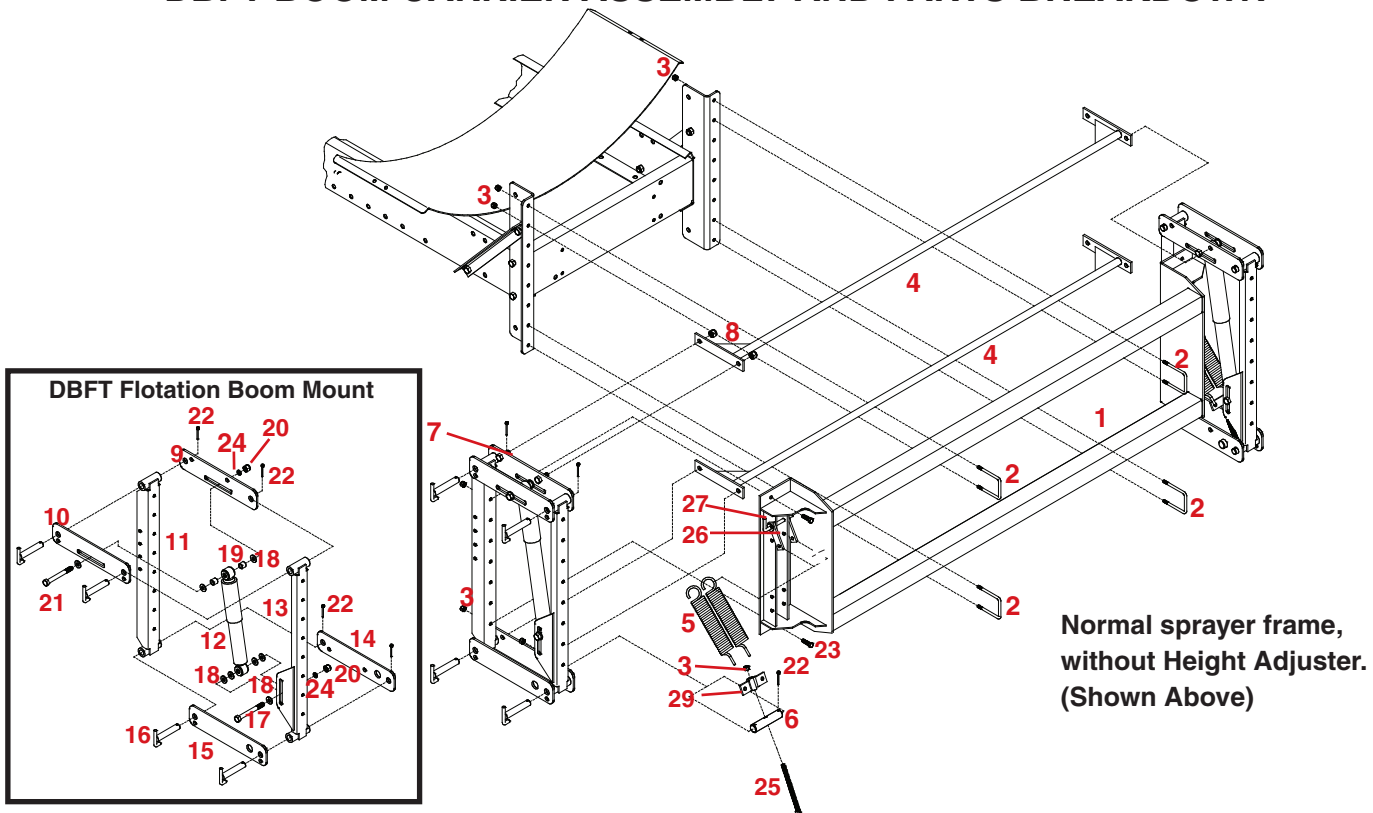

DBFT ASSEMBLY INSTRUCTIONS

- Begin by connecting the upper plate (#10) and upper torsion plate (#9) to the front carrier channel (#11) and the rear floating channel (#13) using the connecting pins (#16).
- Use cotter pin (#22) to retain the connecting pins.
- Bolt the shock absorber (#12) to the rear floating channel (#13) as shown using the 1/2" x 3-1/2" bolt (#17), six 1/2" flatwashers (#18), and 1/2" hex nut (#20).
- Fasten the shock absorber to the upper plates using the two shock spacers (#19), 1/2" x 4-1/2" bolt (#21), four 1/2" flatwashers (#18), and 1/2" hex nut (#20).
- Connect the lower plate (#15) and lower torsion plate (#14) to the front carrier channel (#11) and the rear channel (#13) using the connecting pins (#16). **NOTE: The lower plates are not both the same and must be installed as shown for left-hand assembly (opposite for right side).**
- Slide the spring anchor pin (#6) through the hole in the lower plates (#14 & 15), using cotter pins (#22) to retain the spring anchor pin.
- Connect mounting plates (#25) to the front carrier channel (#11) with pin (#26) and secure it with hair pin.
- Hook one end of the springs (#5) to the mounting plates (#25) and the other end through the tension plate (#29) and secure by using 3/8" x 6" bolt (#24), through the spring anchor pin (#6) and fasten with 3/8" flatwasher and 3/8" hexnut, and 3/8" locknut.

ASSEMBLY INSTRUCTIONS

- Begin by Mounting the Boom Carrier (#1) to the Mounting Angles on the back of the sprayer frame using four 3/8" x 2-1/2" square U-bolts (#2) and eight 3/8" nylon locknuts (#3).
- Attach the DBFT Flotation Boom Mount to each end of the Boom Carrier (#1), secure using four 3/8" x 1-1/4" bolts (#23) and four 3/8" locknuts (#3).
- Mount the Torsion Bars (#4) to the DBFT Mounts on both sides, top and bottom using eight 1/2" x 1-1/4" bolts and eight 1/2" locknuts (#8) as shown.

PARTS LIST

REF. NO.	PART NO.	QTY.	DESCRIPTION
6.	00198-95	2	Spring Anchor Pin
7.	00967	8	1/2"-13 UNC x 1-1/4" Hex Head Bolt
8.	02178	12	1/2"-13 UNC Nylon Insert Locknut
9.	00187-30	2	Upper Parallel Torsion Plate
10.	00186-30	2	Upper Parallel Plate
11.	00188-30	2	Front Carrier Channel
12.	00192-30	2	Shock Absorber
13.	00189-30	2	Rear Floating Channel
14.	00197-30	2	Lower Parallel Torsion Plate
15.	00196-30	2	Lower Parallel Plate
16.	00190-30	8	Connecting Pin
17.	01897	2	1/2"-13 UNC x 3-1/2" Hex Head Bolt
18.	00085	20	1/2" Flatwasher
19.	00193-95	4	Shock Spacers
20.	00083	8	1/2"-13 UNC Hex Nut
21.	01338	2	1/2"-13 UNC x 4-1/2" Hex Head Bolt Gr.5
22.	00191	12	Cotter Pin
23.	00523	4	3/8"-16 UNC x 1-1/4" Hex Head Bolt Gr.8
24.	00178	2	3/8"-16 UNC x 6" Hex Head Bolt
25.	02967-95	4	Spring Mounting Plate
26.	00199-95	2	Pin
27.	00182	2	Small Hair Pin (not shown)
28.	07836-95	2	Tension Bolt Plate
29.	00059	8	3/8" Flatwasher

PARTS LIST

REF. NO.	PART NO.	QTY.	DESCRIPTION
1.	*03844	1	Boom Carrier
2.	01887	4	3/8"-16 UNC x 2-1/2" U-bolt
3.	02592	10	3/8"-16 UNC Nylon Insert Locknut
4.	00201-30	2	Torsion Bars
5.	00200-30	2	Spring (DFB 45)
-	07838-51	4	Spring (DFB 60)

Please order replacement parts by PART NO. and DESCRIPTION.
 * Please specify Red (-10) or Green(-20) when ordering replacement part

MOUNTING THE DBFT BOOM CARRIER WITH HYDRAULIC HEIGHT ADJUST (DMBHAH OPTION)

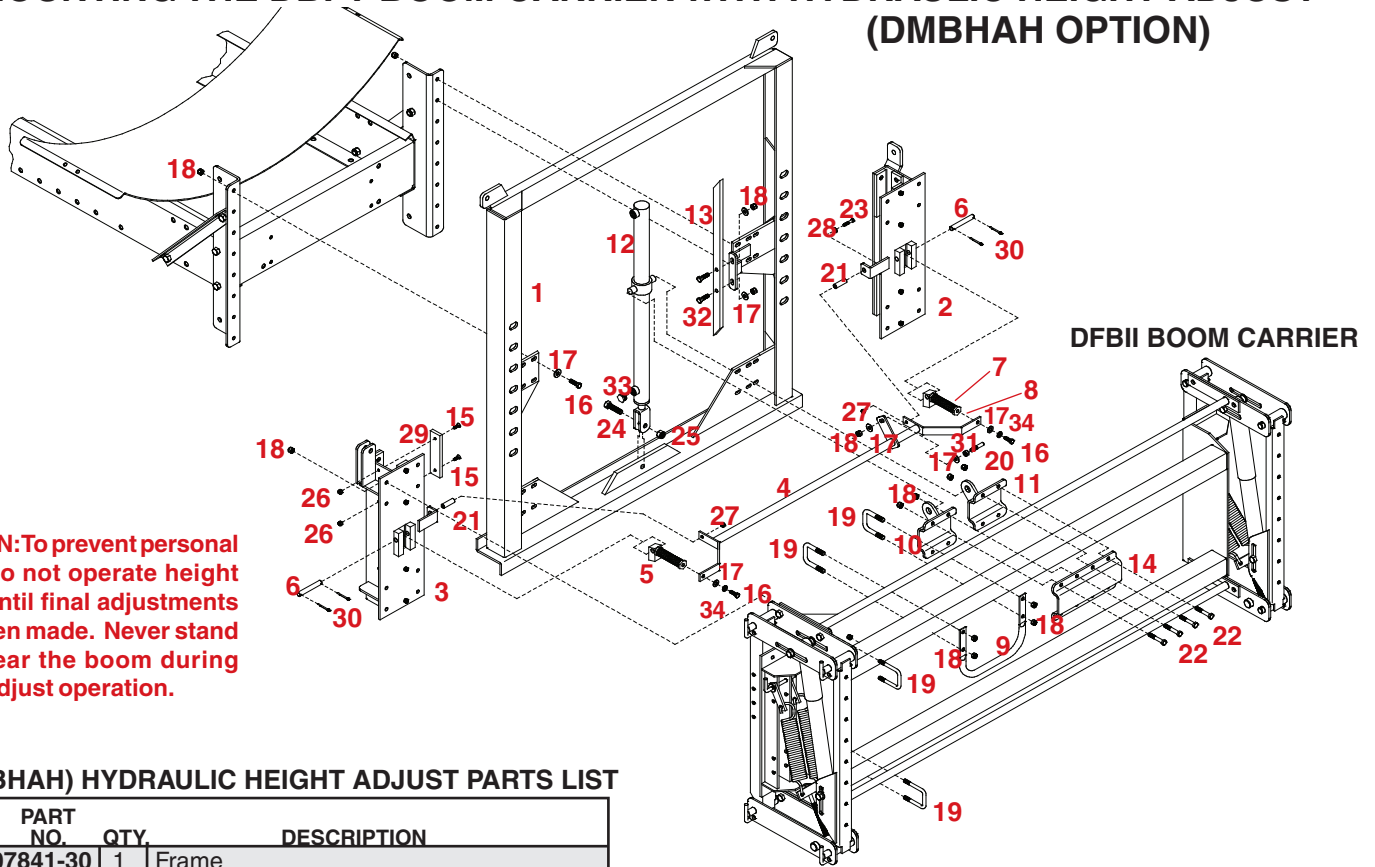

CAUTION: To prevent personal injury, do not operate height adjust until final adjustments have been made. Never stand on or near the boom during height adjust operation.

(DMBHAH) HYDRAULIC HEIGHT ADJUST PARTS LIST

REF. NO.	PART NO.	QTY.	DESCRIPTION
1.	07841-30	1	Frame
2.	07843-30	1	Right Slide Bracket
3.	07842-30	1	Left Slide Bracket
4.	07844-30	1	Latch Actuator
5.	07846-30	2	Latch Assembly (includes #7 & #8)
6.	07851-95	2	Latch Pin
9.	07852-30	1	Hose Keeper
10.	07848-30	1	Left Cylinder Mount
11.	07849-30	1	Right Cylinder Mount
12.	05600-30	1	Cylinder
13.	07845-30	1	Slide Bar
14.	07850-30	1	Cylinder Mount Backup Plate
15.	05732	24	1/4"-20 UNC x 1" Slotted Flat Head Screw
16.	00523	10	3/8"-16 UNC x 1-1/4" Hex Head Bolt
17.	00059	14	3/8" Flatwasher
18.	02592	31	3/8"-16 UNC Nylon Insert Locknut
19.	01887	6	3/8"-16 UNC x 2-1/2" Sq. U-bolt
20.	07854-95	1	Slide Guide Stud
21.	01212-95	2	Bushing 1/2" O.D. x 5/16" I.D. x 5/8" Lg.
22.	02494	8	3/8"-16 UNC x 2-1/4" Hex Head Bolt
23.	00372	2	5/16"-18 UNC x 1-1/2" Hex Head Bolt
24.	01253	1	1/2"-13 UNC x 2" Hex Head Bolt
25.	02178	1	1/2"-13 UNC Nylon Insert Locknut
26.	02772	24	1/4"-20 UNC Nylon Insert Locknut
27.	02802	2	5/16"-18 UNC Nylon Insert Locknut
28.	00004	2	5/16" Flatwasher
29.	03324	12	UHMW Strip
30.	00191	4	Cotter Pin
31.	00061	1	3/8"-16 UNC Hex Nut
32.	00914	2	3/8"-16 UNC x 1-1/2" Hex Head Bolt
33.	00288	1	Air Vent - Hydraulic Cylinder
34.	00060	2	3/8" Lock Washer
-	5222	-	Cylinder Repair Kit

Please order replacement parts by **PART NO.** and **DESCRIPTION.**

ASSEMBLY INSTRUCTIONS

- Mount the height adjust frame (#1) to the boom mounting brackets on sprayer frame (not shown) using eight 3/8" x 1-1/4" bolts, eight 3/8" flatwashers, and eight 3/8" locknuts. Note: The mounting brackets may need to be turned in or out depending on sprayer frame width.
- Attach twelve UHMW strips (#29) to the left and right slide brackets (#2 & #3) using twenty-four 1/4" x 1" slotted head screws (#15), and twenty-four 1/4" locknuts (#26).
- Slide left and right slider brackets (#2 & #3) onto the mainframe (#1). Next install both latches (#5) onto slider brackets using pins (#6), and four cotter pins (#30). Slide each slider bracket up until latches fall into first slot (be sure both latches are in the same slot on each upright).
- Attach the latch actuator (#4) to the slider brackets using two 5/16" x 1-1/2" bolts (#23), two bushings (#21), two 5/16" flatwashers (#28), and two 5/16" locknuts (#27). Attach DFBII boom carrier to the slider brackets using sixteen 3/8" x 2-1/2" Sq. U-bolts (#19), and thirty-two 3/8" locknuts (#18).
- Attach latch actuator (#4) to latches using two 3/8" x 1-1/4" bolts (#16), two lock washers (#34) and two 3/8" flatwashers (#17). Mount slide bar (#13) to frame (#1) using two 3/8" x 1-1/2" bolts (#32), two 3/8" flatwashers (#17), and two 3/8" locknuts (#18). Install slide guide (#17) to latch actuator (#4) using two flatwashers (#17), one 3/8" hex nut (#31), and one 3/8" locknut (#18). Mount the hose keeper (#9) to the upper tube of the DFBII boom carrier using two 3/8" x 2-1/2" Sq. U-bolts (#19), and four 3/8" locknuts (#18).
- Mount cylinder (#12) to the frame (#1) using 1/2" x 2" bolt (#24), and 1/2" locknut (#25). Attach cylinder to the DFBII boom carrier using left and right cylinder mounts (#10 & #11), and cylinder mount backup plate (#14), eight 3/8" x 2-1/4" bolts (#22), and eight 3/8" locknuts (#18).
- Install air vent (#33) to bottom of cylinder with hole down to keep water out.

BOOM CENTER SECTION ASSEMBLY AND PARTS BREAKDOWN

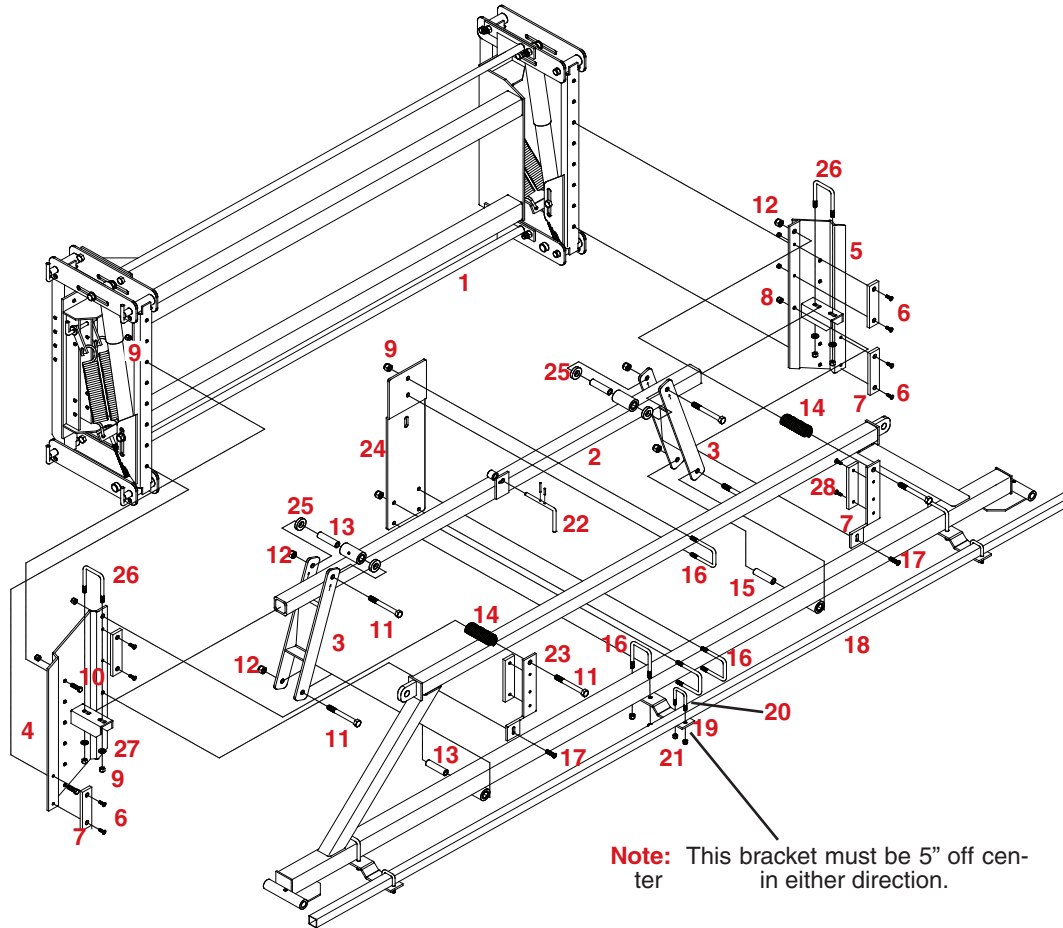

ASSEMBLY INSTRUCTIONS

1. After the boom carrier is assembled and mounted, begin assembling the center section.
2. Mount the left and right conversion brackets (#4,5) to the DBFT boom carrier (as shown) using six 3/8" x 1-1/2" bolts (#10), and six 3/8" Locknuts (#9).
3. Next attach the UHMW wear pads (#7) to the conversion brackets (#4,5), using eight 1/4" x 1" flat head screws (#6), and eight 1/4" locknuts (#8).
4. Mount the boom carrier floater tube (#2) on to the conversion brackets using two 3/8" x 2" square U-bolts (#26), four 3/8" flat washers (27), and four 3/8" locknuts (#9) as shown.
5. Now attach the auto-level linkage brackets (#3) to the floater tube (#2) using two 1/2" x 4-1/2" bolts (#11), two pivot bushings (#13), four plastic spacer bushings (#25) and two 1/2" locknuts (#12). NOTE: Make sure the arrows on the linkage are up as shown above.
6. Mount the boom center section (#15) to the boom carrier assembly. Secure the linkages (#3) to the bottom of the boom center section (#15) using two 1/2" x 4-1/2" bolts (#11), two pivot bushings (#13) and two 1/2" locknuts (#12).
7. Assemble the UHMW wear pads (#7) to the auto-level sway control guides (#23) using four 1/4" x 1" slotted flat head screws (#6), and four 1/4" locknuts (#8). Mount the sway control guides (#23) with UHMW wear pads to the right and left conversion brackets (#4 & 5) using two 3/8" x 1-1/2" carriage bolts (#17), and two 3/8" locknuts (#9). Bolt the top of the sway control guides (#23) to the conversion brackets using two 1/2" x 4-1/2" bolts (#11), two springs (#14) and two 1/2" locknuts (#12). Mount the center locking bracket (#24), to the boom center section (#15) with three 3/8"-16 UNC x 2-1/2" square U-bolts (#16), and six 3/8" locknuts (#9) as shown.
8. Assemble the center boom nozzle mounting plates (#19) to the center section (#15) as shown using three 3/8" x 2-1/2" sq. U-bolts (#16) and six 3/8" locknuts (#9). Next mount the center nozzle tube (#18) to the mounting plates (#19) using three 5/16" x 1-1/4" sq. U-bolts (#20) and six 5/16" locknuts (#21). Insert Auto level latch pin (#22) through boom carrier floater tube (#2) and center locking bracket (#24) as shown.

PARTS LIST

REF. NO.	PART NO.	QTY.	DESCRIPTION
1.	----	1	DBFT Boom Carrier (see breakdown on page 12)
2.	02942-30	1	Boom Carrier Floater
3.	03312-30	2	Auto-Level Linkage
4.	03845-30	1	Left Conversion Bracket
5.	03846-30	1	Right Conversion Bracket
6.	05733	12	1/4"-20UNC x 1" Slotted Flat Head
7.	03324	6	UHMW Wear Pad
8.	02772	12	1/4"-20 UNC Hex Nylon Insert Locknut
9.	02592	26	3/8"-16UNC Nylon Insert Locknut
10.	04056	8	3/8"-16 UNC x 1-1/2" Hex Head Bolt Gr.8
11.	01338	6	1/2"-13 UNC x 4-1/2" Hex Head Bolt Gr.5
12.	02178	6	1/2"-13 UNC Nylon Insert Locknut
13.	03313-95	4	Pivot Bushing (2-7/8" long)
14.	01348-30	2	Spring
15.	*03314	1	Center Section
16.	01887	8	3/8"-16 UNC x 2-1/2" Square U-Bolt
17.	00597	2	3/8"-16 UNC x 1-1/2" Carriage Bolt
18.	03333-30	1	Center Nozzle Mounting Tube
19.	03334-30	3	Center Nozzle Tube Mounting Plate
20.	00909	3	5/16"-18UNC x 1-1/4" Sq. U-Bolt
21.	02802	6	5/16"-18UNC Nylon Insert Locknut
22.	02951-95	1	Auto-Level Latch Pin
23.	02945-30	2	Auto-Level Sway Guide
24.	03847-30	1	Center Locking Bracket
25.	03854	4	Plastic Spacer Bushing
26.	02128	2	3/8" - 16 UNC x 2" Square U-Bolt
27.	00059	4	3/8" Flat washer
28.	00516	4	1/4" - 20 UNC x 3/4" Stove Bolt

Please order replacement parts by PART NO. and DESCRIPTION.

*Please specify Red (-10) or Green (-20) when ordering replacement part

LEFT INNER WING PARTS BREAKDOWN

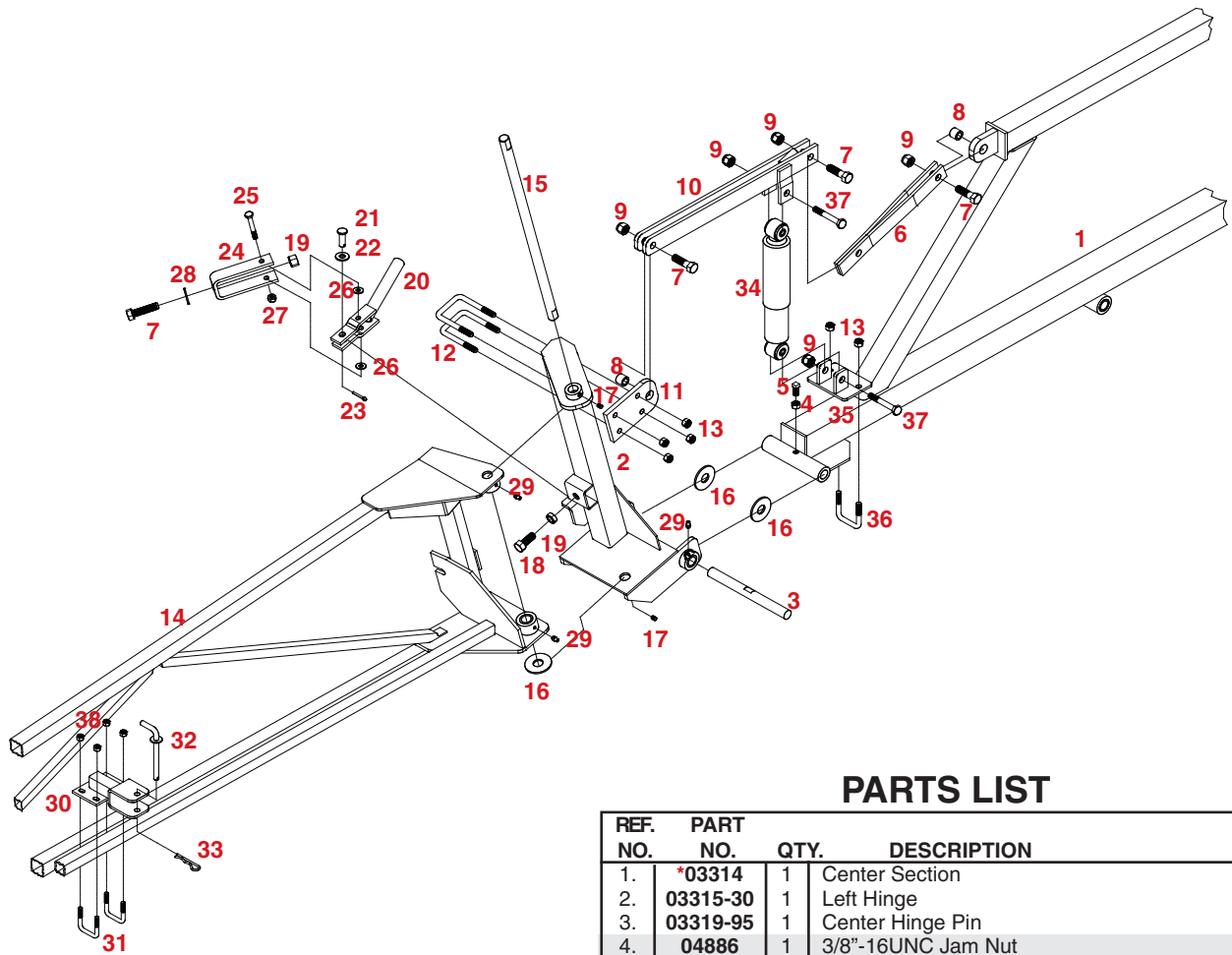

ASSEMBLY INSTRUCTIONS

1. Attach the upper offset linkage (#6) to center section (#1) using one 1/2" x 2" bolt (#7), bushing (#8) and one 1/2" locknut (#9).
2. Next attach the lower linkage bracket (#10) to the upper offset linkage (#6) using one 1/2" x 2" bolts (#7) and one 1/2" locknut (#9).
3. Mount the left center hinge (#2) to the center section (#1). Secure with pin (#3), 3/4" machine washer (#16), 3/8" x 3/4" setscrew (#5) and 3/8" jam nut (#4).
4. Bolt the shock mounting bracket (#35) to the center section (#1) using one 3/8" x 2-1/2" square U-bolt (#36), and two 3/8" locknuts (#13). Insert shock (#34) into shock mounting bracket (#35) as shown. Secure using one 1/2" x 2-1/2" bolt (#37), and one 1/2" locknut (#9).
5. Bolt the linkage mounting plate (#11) to the left center hinge (#2) as shown using two 3/8" x 2-1/8" U-bolts (#12) and four 3/8" locknuts (#13). Bolt the lower linkage bracket (#10) to the linkage mounting plate (#11) using one 1/2" x 2" bolt (#7), bushing (#8), and one 1/2" locknut (#9). Bolt shock (#34) to the shock mounts provided on lower linkage bracket (#10) using one 1/2" x 2-1/2" bolt (#37), and one 1/2" locknut (#9).
6. Attach the left inner wing (#14) to the left center hinge (#2) with the 3/4" machine washer (#16) between the wing and hinge, using the inner hinge pin (#15). Secure with two 5/16" x 1/2" setscrews (#17).
7. Insert the 1/2" x 1-1/2" bolt (#18) and 1/2" nut (#19) into the left hinge (#2) as shown above.
8. Assemble the wing latch handle (#20) to the left hinge (#2) using the 7/16" clevis pin (#21), 3/8" flatwasher (#22) and secure with 5/32" x 1" cotter pin (#23). Next attach the wing latch channel (#24) to the wing latch handle (#20) using one 5/16" x 2-1/2" bolt (#25), two 5/16" flatwashers (#26), and one 5/16" locknut (#27). Next screw the 1/2" x 2" bolt (#7) with flatwasher (#28) into the wing latch channel (#24) and secure with 1/2" jam nut (#19) on back side.
9. Bolt the wing storage bracket (#30) to the left wing approximately 23" from latch plate on the left wing, using two 1/4" x 1-1/16" sq. U-bolt (#31) and four 1/4" locknuts (#38).

PARTS LIST

REF. NO.	PART NO.	QTY.	DESCRIPTION
1.	*03314	1	Center Section
2.	03315-30	1	Left Hinge
3.	03319-95	1	Center Hinge Pin
4.	04886	1	3/8"-16UNC Jam Nut
5.	00095	1	3/8"-16UNC x 3/4" Square Head Setscrew
6.	00171-30	1	Upper Offset Linkage Bracket
7.	01253	4	1/2"-13UNC x 2" Hex Head Bolt Gr.5
8.	00193-95	2	Bushing (3/4" O.D. x 1/2" I.D. x 5/8" lg.)
9.	02178	5	1/2"-13UNC Nylon Insert Locknut
10.	03849-30	1	Lower Linkage Bracket
11.	03318-95	1	Linkage Mounting Plate
12.	05294	2	3/8"-16UNC x 2-1/8" Square U-bolt
13.	02592	6	3/8"-16UNC Nylon Insert Locknut
14.	*03322	1	Left Inner Wing
-	*03396	1	Left Inner Wing (for 60' boom)
15.	03321-95	1	Inner Hinge Pin (3/4" x 20")
16.	02534	3	3/4" x 14 Ga. Machine Washer
17.	04220	2	5/16"-18UNC x 1/2" Set Screw
18.	01254	1	1/2"-13UNC x 1-1/2" Hex Head Bolt Gr.5
19.	00640	2	1/2"-13UNC Jam Nut
20.	05309-95	1	Wing Latch Handle
21.	00080	1	7/16" x 1-1/4" lg. Clevis Pin
22.	00059	2	3/8" Flatwasher
23.	00185	1	5/32" x 1" lg. Cotter Pin
24.	05310-95	1	Wing Latch Channel
25.	04221	1	5/16"-18UNC x 2-1/2" Hex Head Bolt Gr.5
26.	00004	2	5/16" Flatwasher
27.	02802	1	5/16"-18UNC Nylon Insert Locknut
28.	00205	1	7/16" Flatwasher
29.	04642	4	Zerk
30.	03335-30	1	Storage Bracket
31.	04822	2	1/4"-20UNC x 1-1/16" Square U-bolt
32.	00199-95	1	3/8" Dia. x 3-1/2" lg. Lock Pin
33.	00182	1	1/8" Small Hair Pin
34.	03331-30	1	Shock Absorber
35.	03852-30	1	Shock Mount Bracket
36.	01887	1	3/8"-16 UNC x 2-1/2" Sq. U-bolt
37.	01264	2	1/2"- 13 UNC x 2-1/2" Hex Head Bolt
38.	02772	4	1/4" Nylon Insert Locknut

Please order replacement parts by PART NO. and DESCRIPTION.

* Please specify Red (-10) or Green (-20) when ordering replacement part.

RIGHT INNER WING PARTS BREAKDOWN

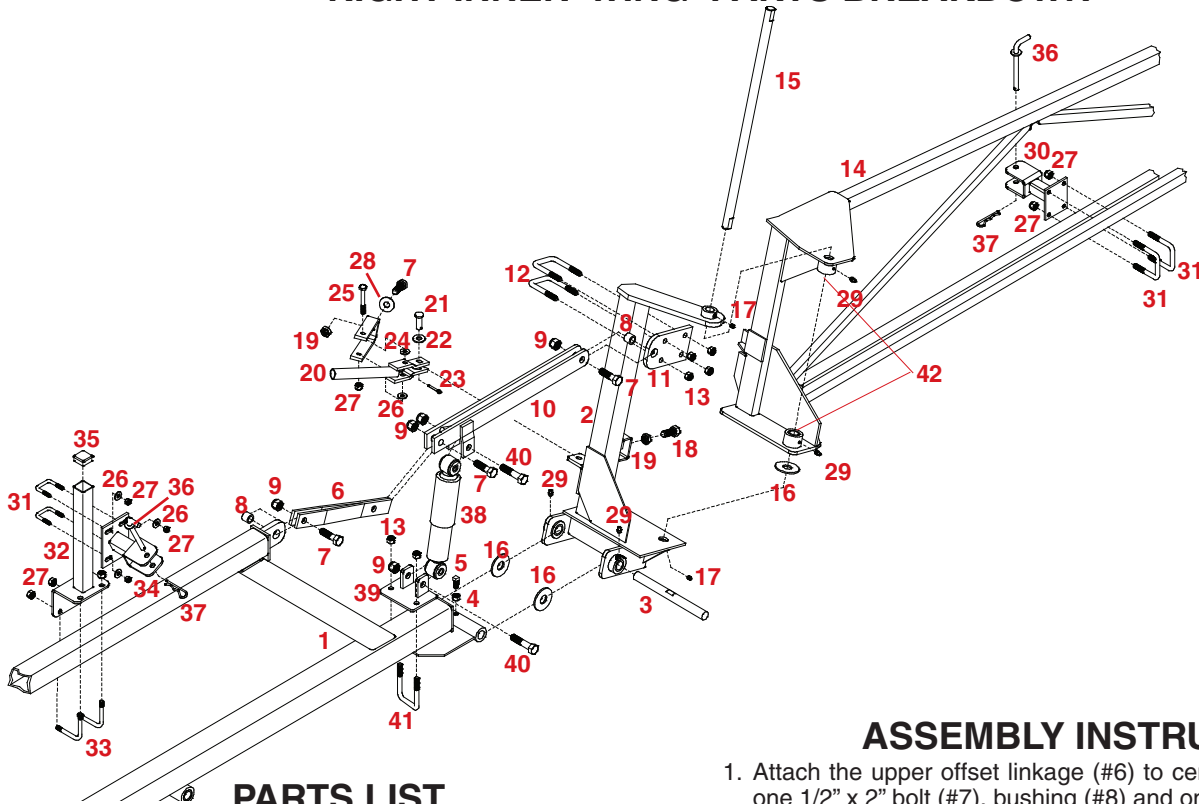

PARTS LIST

REF. NO.	PART NO.	QTY.	DESCRIPTION
1.	*03314	1	Center Section
2.	03316-30	1	Right Hinge
3.	03319-95	1	Center Hinge Pin
4.	04886	1	3/8"-16UNC Jam Nut
5.	00095	1	3/8"-16UNC x 3/4" Square Head Setscrew
6.	00171-30	1	Upper Offset Linkage Bracket
7.	01253	4	1/2"-13UNC x 2" Hex Head Bolt Gr.5
8.	00193-95	2	Bushing (3/4" O.D. x 1/2" I.D. x 5/8" lg.)
9.	02178	5	1/2"-13UNC Nylon Insert Locknut
10.	03849-30	1	Lower Linkage Bracket
11.	03318-95	1	Linkage Mounting Plate
12.	05294	2	3/8"-16UNC x 2-1/8" Square U-bolt
13.	02592	6	3/8"-16UNC Nylon Insert Locknut
14.	*03323	1	Right Inner Wing
-	*03395	1	Right Inner Wing (for 60 ft. boom)
15.	03321-95	1	Inner Hinge Pin
16.	02534	3	3/4" x 14 Ga. Machine Washer
17.	04220	2	5/16"-18UNC x 1/2" Set Screw
18.	01254	1	1/2"-13UNC x 1-1/2" Hex Head Bolt Gr.5
19.	00640	2	1/2"-13UNC Jam Nut
20.	05309-95	1	Wing Latch Handle
21.	00080	1	7/16" x 1-1/4" lg. Clevis Pin
22.	00059	2	3/8" Flatwasher
23.	00185	1	5/32" x 1" lg. Cotter Pin
24.	05310-95	1	Wing Latch Channel
25.	04221	1	5/16"-18UNC x 2-1/2" Hex Head Bolt Gr.5
26.	00004	6	5/16" Flatwasher
27.	02802	13	5/16"-18UNC Nylon Insert Locknut
28.	00205	1	7/16" flatwasher
29.	04642	4	Zerk
30.	03338-30	1	Storage Bracket
31.	00909	4	5/16"-18UNC x 1-1/4" Sq. U-bolt
32.	03437-30	1	Storage Upright Bracket
33.	05818	2	5/16"-18UNC x 2-1/2" L-bolt
34.	03438-30	1	Storage Cross Tube Bracket
35.	05188	5	1-1/4" Square Cap Plug
-	04739	2	1" Square Cap Plug
36.	00199-95	2	Lock Pin (3/8" O.D. x 3-1/2" lg.)
37.	00182	2	1/8" Small Hairpin
38.	03331-30	1	Shock Absorber
39.	03852-30	1	Shock Mount Bracket
40.	01264	2	1/2"-13 UNC X 2-1/2" Hex Head Bolt
41.	01887	1	3/8"-16 UNC x 2-1/2" Sq. U-bolt
42.	51152	2	Bushing (1"O.D. x .76" I.D. x 1"lg.)

ASSEMBLY INSTRUCTIONS

- Attach the upper offset linkage (#6) to center section (#1) using one 1/2" x 2" bolt (#7), bushing (#8) and one 1/2" locknut (#9).
- Next attach the lower linkage bracket (#10) to the upper offset linkage (#6) using one 1/2" x 2" bolts (#7) and one 1/2" locknut (#9).
- Mount the right center hinge (#2) to the center section (#1). Secure with pin (#3), 3/4" machine washers (#16) and 3/8" x 3/4" setscrew (#5) and 3/8" jam nut (#4).
- Bolt the shock mounting bracket (#39) to the center section (#1) using one 3/8" x 2-1/2" square U-bolt (#41), and two 3/8" locknuts (#13). Insert shock (#38) into shock mounting bracket (#39) as shown. Secure using one 1/2" x 2-1/2" bolt (#40), and one 1/2" locknut (#9).
- Bolt the linkage mounting plate (#11) to the left center hinge (#2) as shown using two 3/8" x 2-1/8" U-bolts (#12) and four 3/8" locknuts (#13). Bolt the lower linkage bracket (#10) to the linkage mounting plate (#11) using one 1/2" x 2" bolt (#7), bushing (#8), and one 1/2" locknut (#9). Bolt shock (#38) to the shock mounts provided on lower linkage bracket (#10) using one 1/2" x 2-1/2" bolt (#40), and one 1/2" locknut (#9).
- Attach the right inner wing (#14) to the right center hinge (#2) with the 3/4" machine washer (#16) between the wing and hinge, using the inner hinge pin (#15). Secure with two 5/16" x 1/2" setscrews (#17).
- Insert the 1/2" x 1-1/2" bolt (#18) and 1/2" jam nut (#19) into the right hinge (#2) as shown above.
- Assemble the wing latch handle (#20) to the right hinge (#2) using the 7/16" clevis pin (#21), 3/8" flatwasher (#22) and secure with 5/32" x 1" cotter pin (#23). Next attach the wing latch channel (#24) to the wing latch handle (#20) using one 5/16" x 2-1/2" bolt (#25), two 5/16" flatwashers (#26) and one 5/16" locknut (#27). Next screw the 1/2" x 2" bolt (#7) with 7/16" flatwasher (#28) into the wing latch channel (#24) and secure with 1/2" jam nut (#19) on back side.
- Bolt the wing storage bracket (#30) to the right wing approximately 23" from latch plate on the left wing, using two 5/16" x 1-1/4" sq. U-bolt (#31) and four 5/16" locknuts (#27).
- Mount all brackets in this step loosely in locations shown. When boom is complete, fold and adjust brackets to support the boom in the folded position. Mount the wing storage upright (#32) to the top of the center section (#1) using two 5/16" x 2-1/2" L-bolts (#33) and four 5/16" locknuts (#27). Attach the storage cross tube (#34) to the storage upright (#32) using two 5/16" x 1-1/4" square U-bolts (#31), four 5/16" flatwashers (#26) and 5/16" nylon insert locknuts (#27). Place the 1-1/4" Cap Plug (#35) in the end of the upright (#32).

* Please specify Red (-10) or Green (-20) when ordering replacement part.

Please order replacement parts by PART NO. and DESCRIPTION.

RIGHT AND LEFT OUTER WING PARTS BREAKDOWN

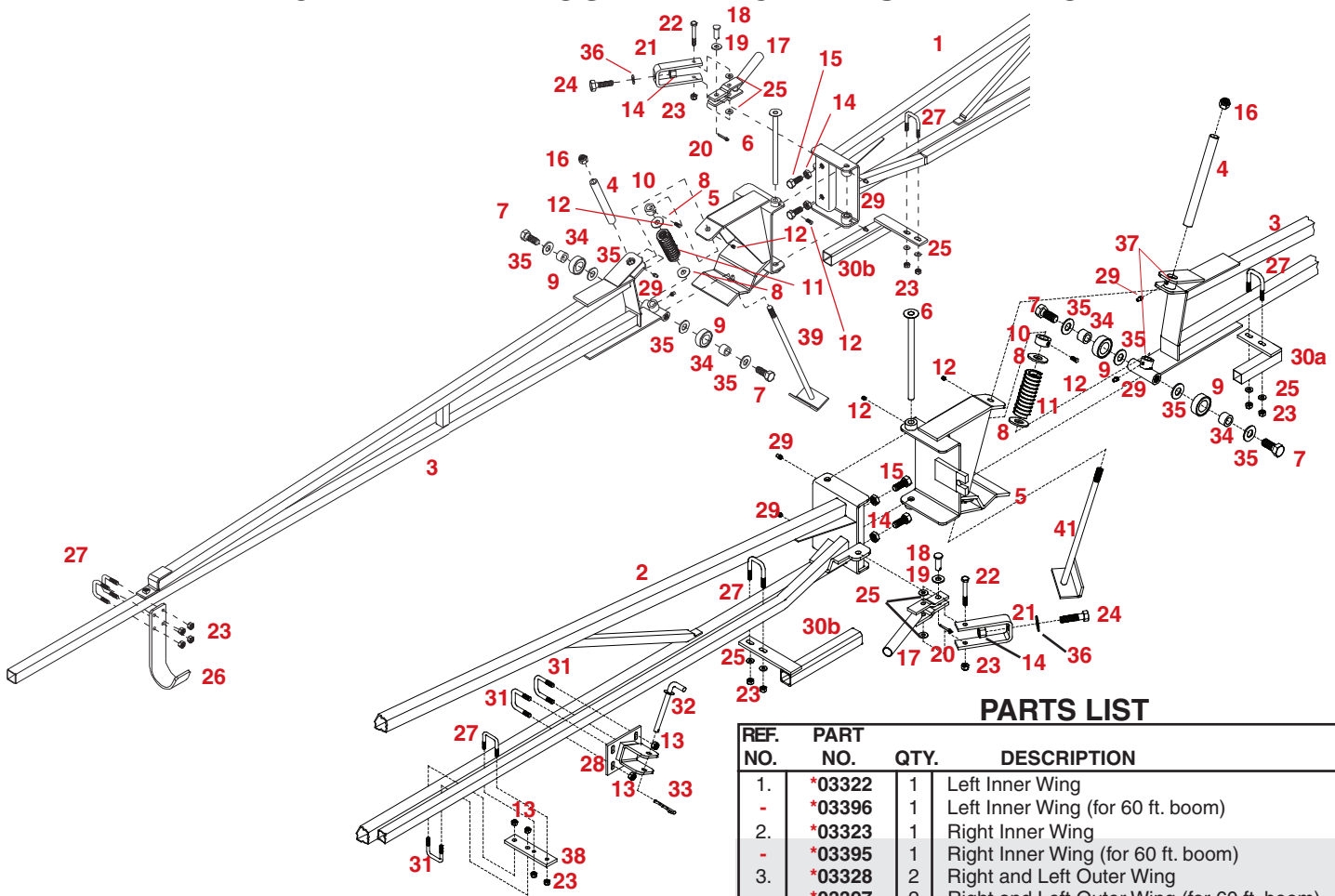

PARTS LIST

REF. NO.	PART NO.	QTY.	DESCRIPTION
1.	*03322	1	Left Inner Wing
-	*03396	1	Left Inner Wing (for 60 ft. boom)
2.	*03323	1	Right Inner Wing
-	*03395	1	Right Inner Wing (for 60 ft. boom)
3.	*03328	2	Right and Left Outer Wing
-	*03397	2	Right and Left Outer Wing (for 60 ft. boom)
4.	11275-95	2	Breakaway Slider Bushing
5.	03325-30	2	Outer Breakaway Hinge
6.	03329-95	2	Outer Hinge Pin
7.	04051	4	5/8"-11 UNC x 1-1/2" Hex Head Bolt Gr.5
8.	00085	4	1/2" Flatwasher
9.	07134	4	Breakaway Roller Bushing (02562 #36 included)
10.	03327-95	2	Lock Collar
11.	05318-30	2	Break-Away Spring
-	03417-51	2	Break-Away Spring (for 60 ft. boom)
12.	07174	6	1/4"-20UNC x 3/4" sq. Head Set Screw (Black)
13.	02772	4	1/4"-20UNC Nylon Insert Locknut
14.	00640	6	1/2"-13UNC Jam Nut
15.	00967	4	1/2"-13UNC x 1-1/4" Hex Head Bolt Gr.5
16.	02178	2	1/2"-13UNC Nylon Insert Locknut
17.	05309	2	Wing Latch Handle
18.	00080	2	7/16" x 1-1/4" lg. Clevis Pin
19.	00059	2	3/8" Flatwasher
20.	00185	2	5/32" x 1" lg. Cotter Pin
21.	05310	2	Wing Latch Channel
22.	04221	2	5/16"-18UNC x 2-1/2" Hex Head Bolt Gr.5
23.	02802	14	5/16"-18UNC Nylon Insert Locknut
24.	01253	2	1/2"-13 UNC X 2" Hex Head Bolt Gr.5
25.	00004	4	5/16" Flatwasher
26.	05297-30	2	Tip Protector
27.	00909	6	5/16"-18UNC x 1-1/4" Square U-bolt
28.	03439-30	1	Storage Bracket
29.	04642	4	Zerk
30a.	05319-30	2	Tip Offset Bracket (for 45 ft. and 50 ft. boom)
30b.	03398-30	2	Tip Offset Bracket (for 60 ft. boom)
31.	04822	2	1/4"-20UNC x 1-1/16" Square U-bolt
32.	00199-95	1	Lockpin (3/8" O.D. x 3-1/2" lg.)
33.	00182	1	1/8" Small Hairpin
34.	02562-95	4	Spacer Bushing
35.	00477	8	5/8" Flatwasher
36.	00205	2	7/16" Flatwasher
37.	57215	2	Bushing (5/8" O.D. x 1/2" I.D. x 3/4" lg.)
38.	03537-95	4	Nozzle Tube Brace Bracket
39.	11274-95	2	Breakaway Pin

ASSEMBLY INSTRUCTIONS

- Attach the outer wing (#3) to the breakaway hinge (#5). Place breakaway bushings (#9), spacer bushings (#36), 5/8" flatwashers (#37) and 5/8" x 1-1/2" bolts (#7) to the outer wing (#3). **Note: use Locktite with #7 bolts.** Slide outer wing (#3) on to the breakaway hinge (#5). Insert breakaway hinge pin (#4) through the outer wing top bushing through the breakaway hinge top bushing, through the lock collar (#10), through the 1/2" flatwasher, spring (#11) and 1/2" flatwasher (#8), through the bottom bushing on the outer wing and through the breakaway hinge, place 1/2" locknut (#16) on the hinge pin (#4) do not tighten. Tighten the 1/4" x 1/2" sq. head setscrew (#12) on the lock collar (#10), now tighten the 1/2" locknut (#16) to compress breakaway spring, the spring should be compressed to about 3-1/4". Do not over compress. Now tighten set screw on hinge (#5). Test breakaway to make sure spring is not over compressed. Must be slight space between coils when boom is broken ahead or back.
- Assemble the outer wing and breakaway hinge to the inner left and right wing (#1 & 2). Insert hinge pin (#6) through the bushings and secure using 1/4" x 3/4" square head set screw (#12).
- Insert four 1/2" x 1-1/4" bolts (#15) and four 1/2" jam nut (#14) into the inner left and right wing (#1 & 2).
- Assemble the wing latch handle (#17) to the inner right and left wing (#1 & 2) using the 7/16" clevis pin (#18), 3/8" flatwasher (#19) and secure with 5/32" x 1" cotter pin (#20). Next attach the wing latch channel (#21) to the wing latch handle (#17) using one 5/16" x 2-1/2" bolt (#22), two 5/16" flatwashers (#25) and one 5/16" locknut (#23). Next screw the 1/2" x 2" bolt (#24) with flatwasher (#38) into the wing latch channel (#21) and secure with 1/2" nut (#14) on back side.
- Bolt the wing storage bracket (#28) to the right inner wing approximately 30" from latch plate, using two 1/4" x 1-1/16" sq. U-bolt (#31) and four 1/4" locknuts (#13).
- Bolt the wing tip protector (#26) to the outer right and left wing (#3) approximately 17" from wing tip. Secure using four 5/16" x 1-1/4" sq. U-bolts (#27) and eight 5/16" locknuts (#23).

* Please specify Red (-10) or Green (-20) when ordering replacement part.

Please order replacement parts by PART NO. and DESCRIPTION.

DFBII Breakaway Hinge Update (Kit #5686)

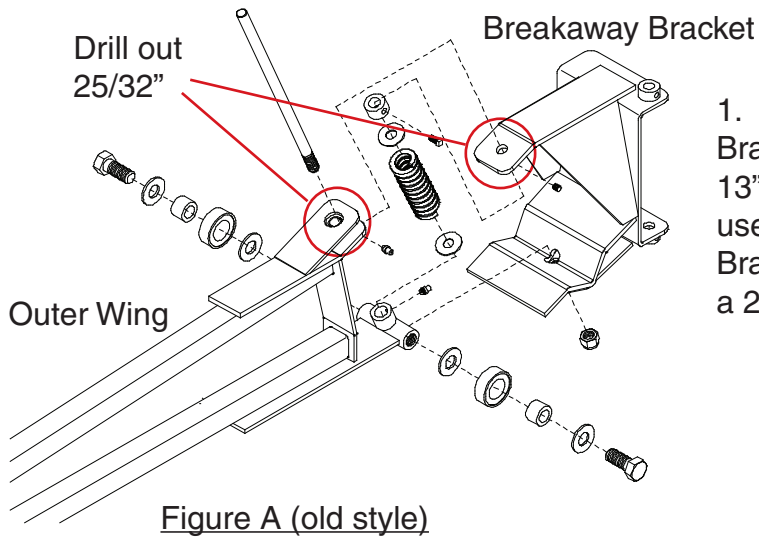

1. Remove Outer Wing from Breakaway Bracket by removing 1/2" Locknut and 13" Pin. Pin and Locknut are no longer used. Drill out the top of the Breakaway Bracket and the top of the Outer Wing with a 25/32" drill bit. (See Figure A)

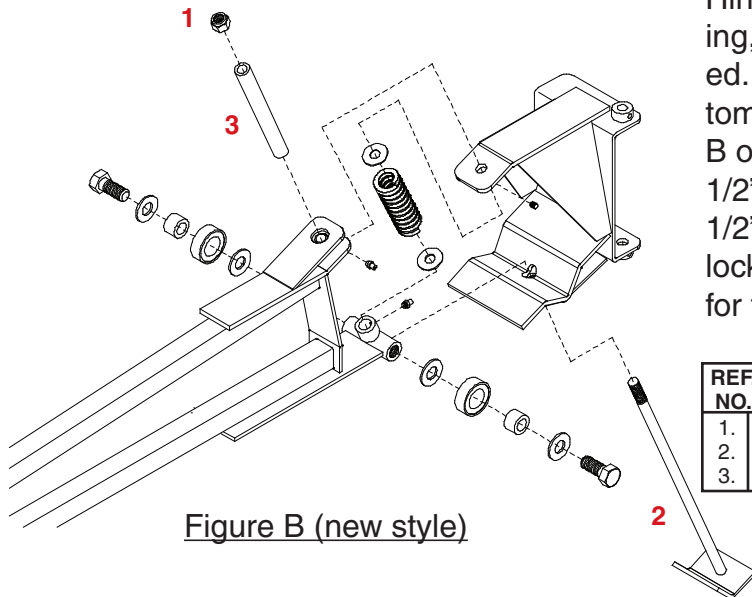

2. Reassemble Outer Wing to Breakaway Hinge using new 13" Pin, new 4 3/8" Bushing, and new 1/2" Locknut which is provided. Note new pin comes up from the bottom of the Breakaway Hinge. (See Figure B on how to assemble the hinge.) Tighten 1/2" Locknut to put tension on bushing. 1/2" of thread should be showing above locknut after tightening. Repeat procedure for the other side of the boom.

REF. NO.	PART NO.	QTY.	DESCRIPTION
1.	02178	2	1/2" NC Nylon Insert Locknut
2.	11274-95	2	Breakaway Pin (new style)
3.	11275-95	2	Breakaway Slider Bushing (new style)

(OPTIONAL) HYDRAULIC BOOM LEVELING PARTS BREAKDOWN

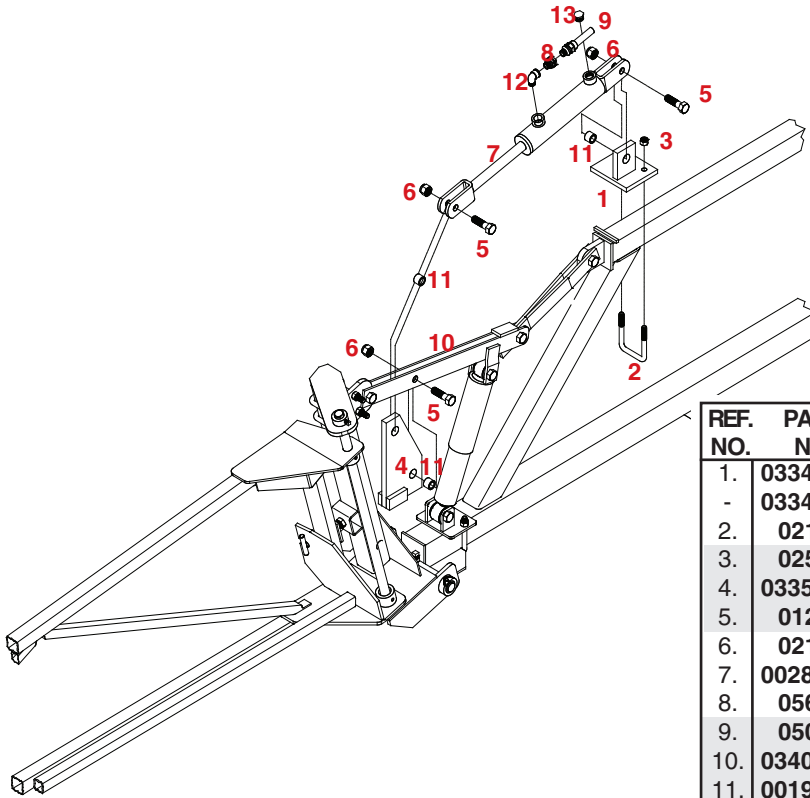

DFHY PARTS LIST

REF. NO.	PART NO.	QTY	DESCRIPTION
1.	03348-30	1	Left DFHY Cylinder Mount
-	03349-30	1	Right DFHY Cylinder Mount
2.	02128	2	3/8"-16UNC x 2" Square U-bolt
3.	02592	4	3/8"-16UNC Nylon Insert Locknut
4.	03350-30	2	Linkage Mount
5.	01253	6	1/2"-13UNC x 2" Hex Head Bolt Gr.5
6.	02178	6	1/2"-13UNC Nylon Insert Locknut
7.	00286-30	2	Hydraulic Cylinder
8.	05661	2	3/8" MPT x 3/8" FPT Orifice Restrictor
9.	05013	2	26' Hydraulic Hose
10.	03405-30	2	Lower Linkage Mount
11.	00193-95	6	Bushing (3/4" OD x 1/2" ID x 5/8"lg.)
12.	05215	2	3/8" Steel Elbow Fitting
13.	00288	2	Air Vent
-	5222	-	Cylinder Repair Kit

(OPTIONAL) WHEEL TIP PROTECTOR PARTS BREAKDOWN

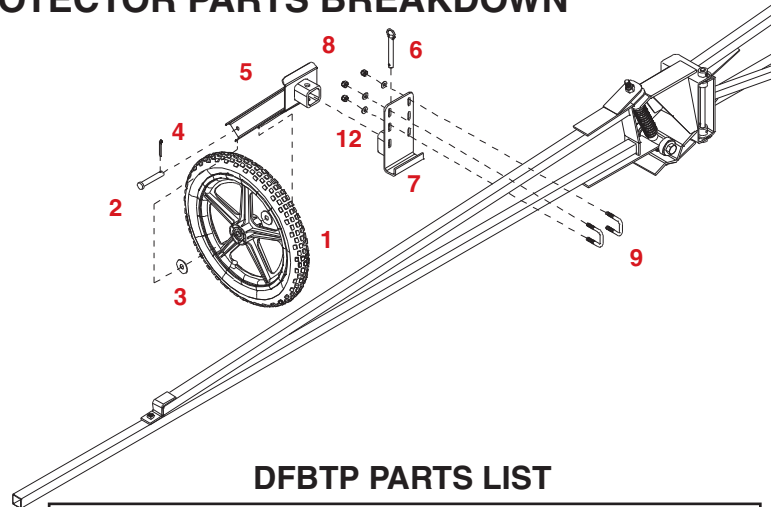
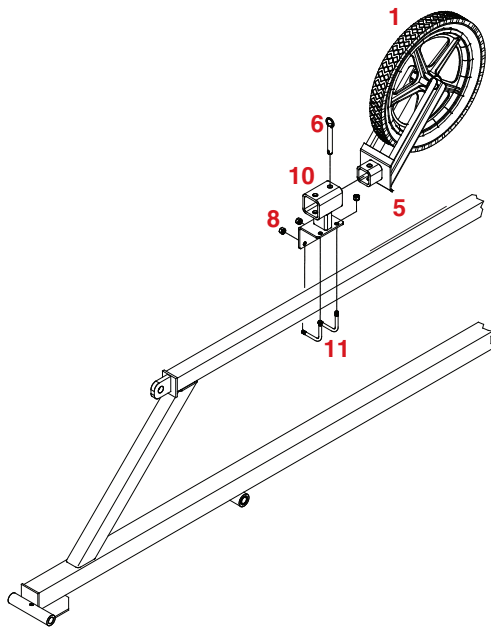

DFBTP PARTS LIST

REF. NO.	PART NO.	QTY	DESCRIPTION
1.	09801	2	Wheel and Tire for Boom Tip Protectors
2.	05619	2	Pin (1/2" x 3" lg.)
3.	02384	4	Machine Washer (1/2" ID x 14 GA.)
4.	00185	2	5/32" x 1 Cotter Pin
5.	05564-30	2	Wheel Fork
6.	05328	2	1/2" x 3" lg. Ball Lock Hitch Pin
7.	05566-30	2	Wing Mounting Plate
8.	02802	12	5/16"-18UNC Nylon Insert Locknut
9.	00909	4	5/16"-18UNC x 1-1/4" Square U-bolt
10.	05567-30	1	Transport Storage Bracket
11.	05818	2	5/16"-18UNC x 2-1/2 L-bolt
12.	00004	8	5/16" Flatwasher

ADJUSTMENT PROCEDURES

After the boom is completely assembled and before attempting to fold the boom for the first time, the boom should be adjusted so it lays straight, both horizontally and vertically. There are several adjustment points built into the boom for this purpose.

1. All adjustments must be done with the boom unfolded and latched. Begin by adjusting the boom center section as it mounts on the mounting arms on the carrier brackets. The square U-bolt that holds the boom carrier floater tube (#2) on the perch welded to the conversion brackets (#4 & #5) must be loosened. The boom carrier floater tube and the boom center section must be pushed forward to ensure that the top of the boom contacts the UHMW wear pad at the top of the carrier bracket. Then retighten the U-bolt. With lock pin out you should be able to oscillate the boom side to side freely, but the top tube of the boom should contact the wear strip at the top of the carrier brackets. Then tighten the 1/2" x 4-1/2" bolt through the auto level sway guide (#23) until the outer UHMW wear strip just contacts the back of the top tube of the boom. This adjustment should not restrict the side to side sway of the boom but should be enough to dampen it and support the boom from excessive rear forces.

2. On sprayers that do not have hydraulic boom wing leveling, the linkage mounting plate (#11) can be adjusted up or down on the vertical tube of the inner hinge bracket to get the wing level. On sprayers with hydraulic wing leveling, this linkage mounting plate must be mounted about 1/2" down from the underside of the top plate to the top of the linkage mounting plate. The hydraulic cylinder in the linkage arms on these sprayers will need to be collapsed slightly to bring the wings up to level for spraying position. It is important that these wings be level when folding the sprayer so the wings fit into all the storage brackets. Be very careful during initial installation and activation until all the air is out of the hydraulic lines and cylinders used in this system.

! CAUTION: To prevent personal injury, never stand under the boom at any time!

3. The outer breakaway hinge can be adjusted for breakaway tension by tightening or loosening the 1/2" locknut (#16). You may have to adjust the lock collar down to get more spring compression. The outer wings should be set to breakaway after a 50 lb force or better if applied to the wing tips. The springs should not be compressed more than 3-1/4 inches.

4. At this time the latches should be adjusted at each hinge, so the wings will be locked securely after unfolding. There are 1/2" bolts at each hinge point that act as a stop; these stop bolts must be adjusted in or out to straighten the lay of the boom. After these bolts are adjusted, the tee bolt in the clevis end of the latch should be adjusted to securely latch each wing. It is important that the latch locks over-center otherwise there will be problems with it coming unlocked. If adjustment is required with the latch not locking over-center, you must grind or file down the latch stop which will then let the latch go over-center and lock securely.

5. After the boom is setup and the storage brackets are placed in their approximate location final adjustments can be made by folding the boom using the proper procedure. Slide the storage brackets into the exact location when the wings are folded and tighten in place. The boom should be supported by the storage brackets so as to avoid wear and twist of the boom when folded.

6. If properly assembled, the height adjust mechanism should require no adjustment. Make sure the latches are securely engaged in the holes in the height adjust frame at all times, except when changing height settings.

! CAUTION: To prevent personal injury or property damage, always make sure the latches are securely locked after any type of height adjustment or before any work is done on the boom.

7. Make sure all fasteners are tight or at the proper tension, and hoses are not in the path of any folding procedures.

WINCH MAINTENANCE

Inspect winch at least once annually and more frequently when the winch is exposed to an environment which is particularly dirty or wet. For continued smooth performance and increased life, occasionally grease gears, reel shaft and handle threads. An occasional drop of oil on the drive shaft bearings is also recommended. **NOTE: Do not oil or grease brake mechanism.**

The winch finish can be protected and will provide longer service if it is periodically washed with water and then wiped with light oil or wax. Inspect the cables and sheaves to make sure they roll freely with no binding. Lubricate the sheaves on the boom occasionally with several drops of lubricating oil.

! WARNING: Keep winch in good working order. Damaged or severely worn parts create unnecessary dangers and could result in personal injury or property damage.

DBFT FLOTATION BOOM MOUNT ADJUSTMENT PROCEDURES

Moving the shock towards the front of the sprayer dampens the floating action of the boom. Moving the shock towards the boom center section increases the floating action of the boom. **Note: When adjusting the shock, the center ends of shock should be held as close to 20" as possible. This is to maintain an equal extending and retracting distance of the shock (see illustration below).** Once the floating position has been set by the shock, the spring tension should be adjusted so that the parallel plates on the floating units are level with the ground.

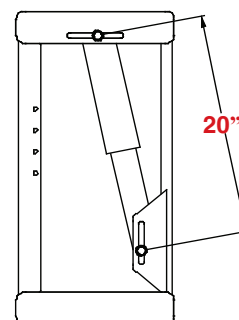

ADJUSTMENTS FOR FOLDING AND STORAGE

If the boom is adjusted correctly it should fold and store very easily. It is important to lock the sway control in its storage position before beginning the folding procedures. If the boom has hydraulic wing tip leveling, it is important that the boom be level before folding. Do not operate these cylinders after the wings are folded as damage may result to the boom.

1. Begin the folding operation at the left side (standing behind the boom looking forward) (1st Fold) of the boom. Unlock the latch and fold the outer wing into the storage bracket and lock in place with pin. Make sure at this time and at every folding and unfolding operation, that the hoses and tips do not interfere or bind around any corners. During all folding operations you must support the wings until they are in the storage brackets, otherwise extreme twisting forces will be created and possibly damage or twist the boom.

2. Next, unlock the latch on the inner left wing (2nd fold) and pull the outer left wing and the inner left wing back and around to fold to the rear of the center section and into the storage bracket and lock in place with pin.

3. On the right side outer wing unlock the latch between the inner and outer right wing. Fold the outer right wing to the front of the inner right wing (3rd fold) and into the storage bracket and lock in place with pin.

4. Finally unlock the latch between the center section and inner right wing (4th fold). Fold the inner right wing and outer right wing back and around to fold to the rear of the center section and into the storage bracket and lock in place with pin. At this time the boom is completely folded and ready for transport.

MAKE SURE ALL PINS ARE LOCKED IN PLACE WITH HAIR PINS.

CHECK ALL HOSES AND TIPS TO MAKE SURE THEY ARE NOT INTERFERING OR HUNG UP ON ANY HINGES OR BOLTS.

DO NOT OPERATE THE HYDRAULIC WING TIP LEVELING WHEN THE BOOM IS FOLDED (if equipped).

DO NOT OPERATE THE HEIGHT ADJUST MECHANISM WITH THE BOOM FOLDED (if equipped).

BEFORE UNHOOKING THE SPRAYER FROM THE TRACTOR, MAKE SURE TO LOWER THE REAR SAFETY STAND (if so equipped) TO PREVENT THE POSSIBILITY OF THE SPRAYER TILTING REARWARD.

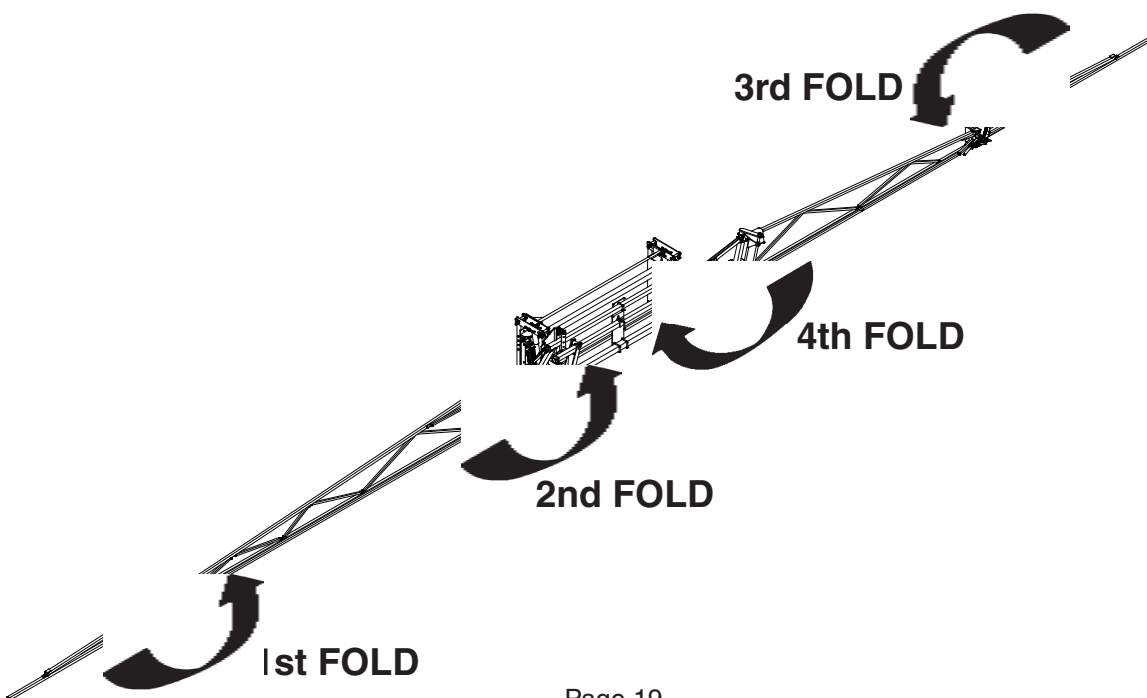

MAINTENANCE AND LUBRICATION

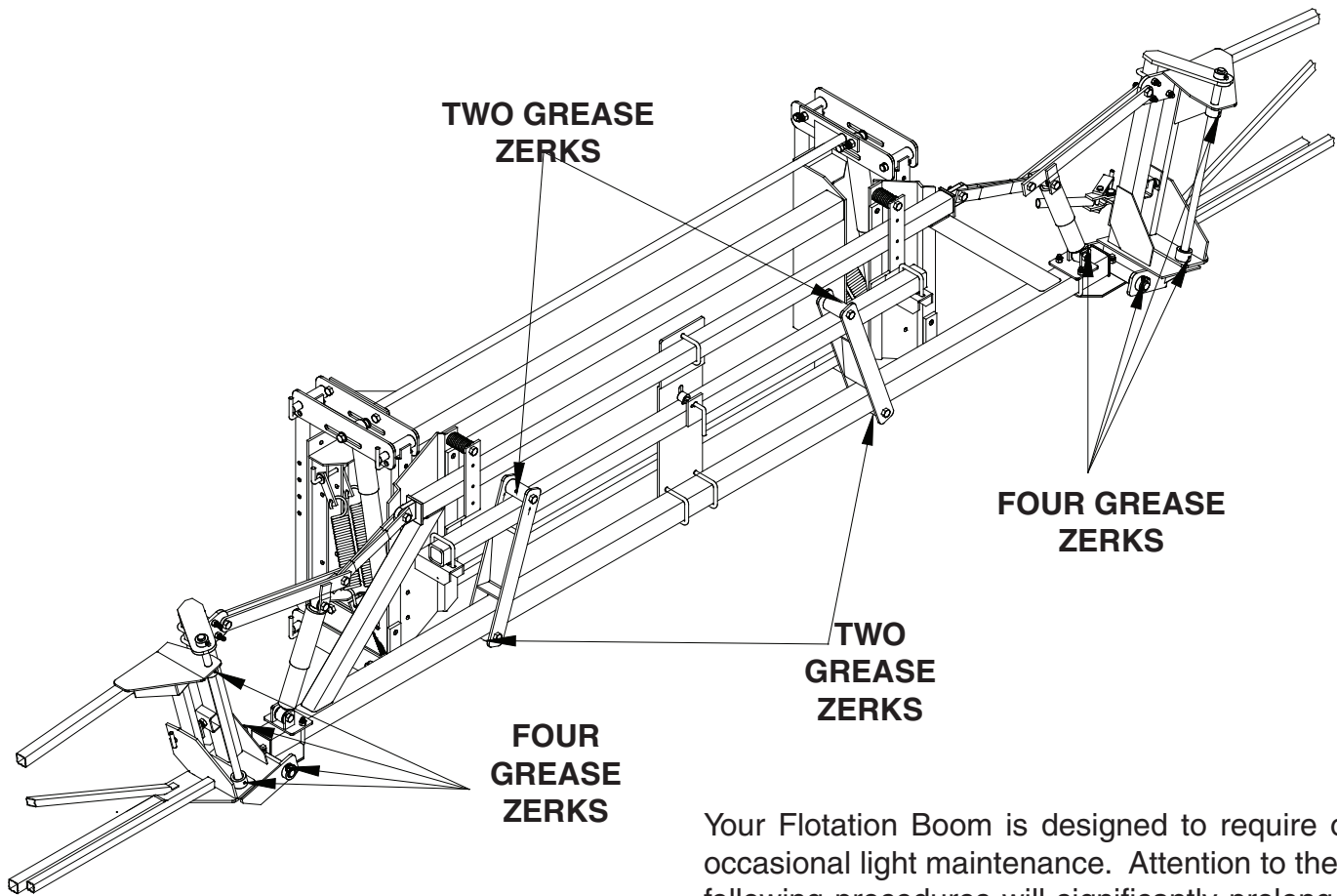

FOUR GREASE ZERKS

TWO GREASE ZERKS

FOUR GREASE ZERKS

Your Flotation Boom is designed to require only occasional light maintenance. Attention to the following procedures will significantly prolong the useful life of your boom.

1. Prior to each use, carefully check all nuts, bolts, fittings, plugs, hoses and hose clamps to see that they are secure.

2. Check the latches to make sure that they are not loose or worn. This must be done daily to prolong their useful life. Wing latches must come over center to latch securely.

3. All Grease Zerks must be greased daily when this boom is in use. Also be certain to replace any missing grease zerks or zerks which will not accept grease.

4. Lubricate the sheaves in the height adjust if so equipped.

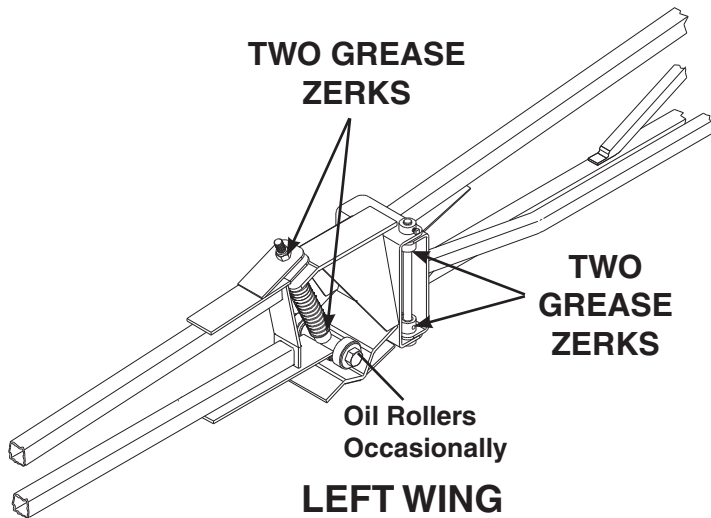

TWO GREASE ZERKS

TWO GREASE ZERKS

Oil Rollers Occasionally

LEFT WING

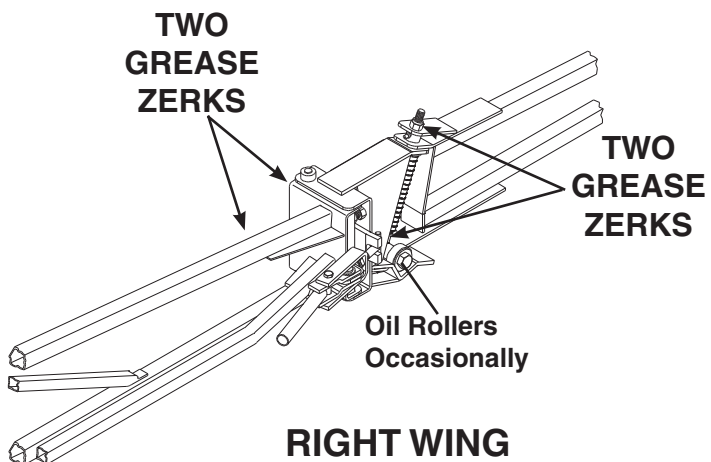

TWO GREASE ZERKS

TWO GREASE ZERKS

Oil Rollers Occasionally

RIGHT WING

TIP PLACEMENT

1. **Marking location of boom clamps:** Mark the clamp locations by starting at the center of the center boom section. From this mark, locate 20 inch spaces to both ends of the boom.

2. **Fasten preassemble boom lines:** Fasten the boom clamps (#3) on the boom so the sprayer tip will be on the back side of the boom. The wing extensions for the 60 foot boom are 1 inch tubing. Therefore, this boom will have two size clamps.

NOTE: 45' Boom 27 Tips
60' Boom 37 Tips

BASIC PLUMBING PARTS LIST

REF. NO.	PART NO.	DESCRIPTION
-	340RB	3/4" Rubber Hose
-	B12H	3/4" Gear Clamp
-	NHT11	Nylon Hose Ties

Please order replacement parts by **PART NO.** and **DESCRIPTION.**

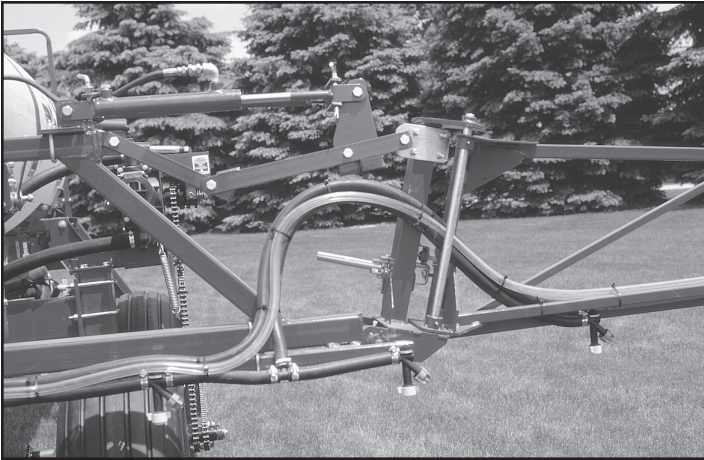

Feeder Line Routing and Tip Placement for Inner Hinge

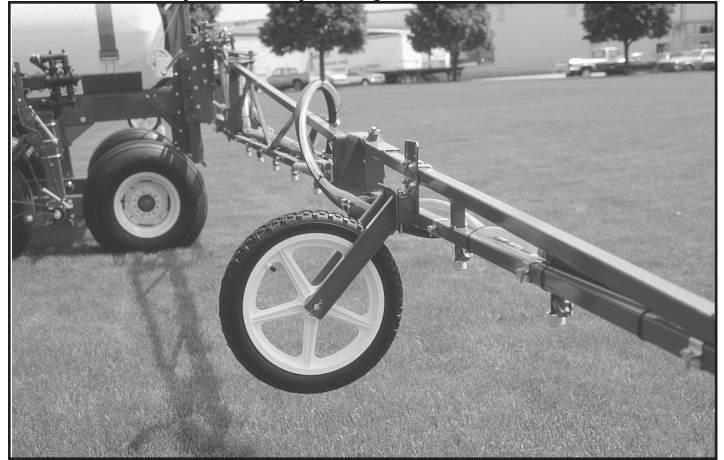

Feeder Line Routing and Tip Placement for Outer Hinge

CONVENTIONAL NOZZLES AND BOOM CLAMPS

1-1/4" BOOM CLAMP PARTS LIST

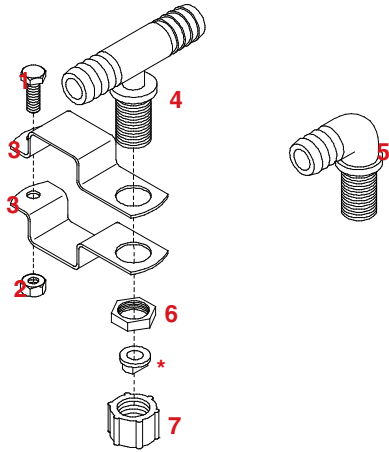

REF. NO.	PART NO.	DESCRIPTION
-	B11 114	1-1/4" Boom Clamp Assembly
1.	00068	1/4"-20UNC x 3/4" Hex Head Bolt
2.	00062	1/4"-20UNC Hex Nut
3.	00337	1-1/4" Boom Clamp
-	00338	1" Boom Clamp

3/4" NOZZLE PARTS LIST

REF. NO.	PART NO.	DESCRIPTION
4.	NTT34	3/4" Nozzle Tee
5.	NTL34	3/4" Nozzle Elbow
6.	B12	Nut
*	-----	Tip (specify tip size) (not included)
7.	8027	11/16" FPS Cap

Please order replacement parts by **PART NO.** and **DESCRIPTION.**

DRIP FREE NOZZLES AND BOOM CLAMPS

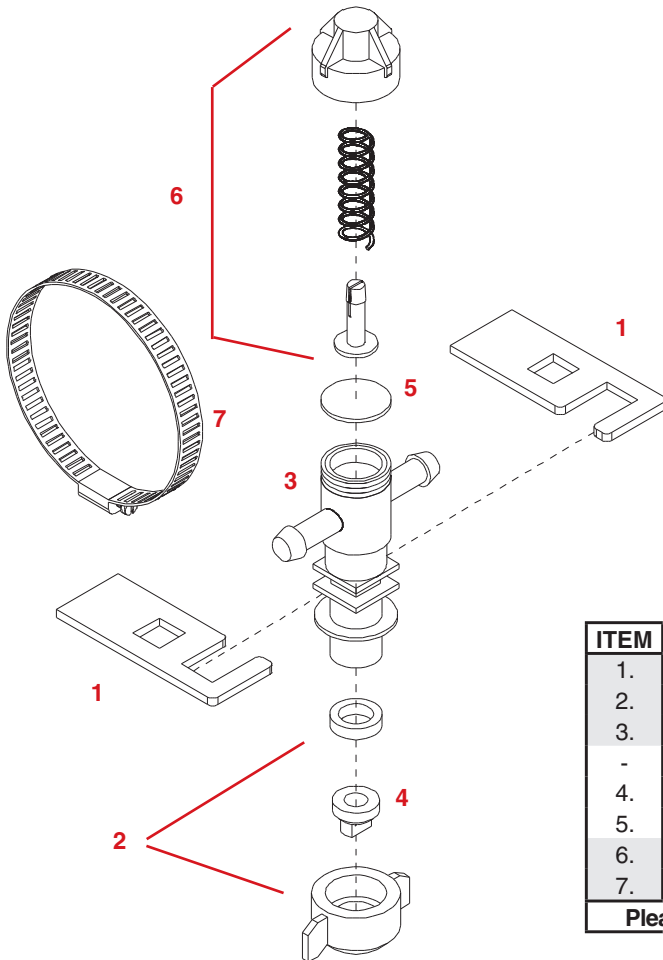

ITEM	PART #	DESCRIPTION	QTY.
1.	10862	Boom Clamp SS	2
2.	07787	Flat Fan Cap (includes EPDM Gasket)	1
3.	09147	3/4" TeeJet Nozzle Elbow	1
-	09148	3/4" TeeJet Nozzle Tee	1
4.	-----	Tip (not included) (specify tip size)	-
5.	21953VI	Diaphragm (viton)	1
6.	21950 10PP	End Cap Assembly	1
7.	B24H	1.25" Clamp Gear	1

Please order replacement parts by **PART NO.** and **DESCRIPTION.**

SPRAYER CALIBRATION PROCEDURES

NOTE: To avoid wind drift, use lower pressure and higher spray volume.

Guidelines For Sprayer Calibration

Before calibrating your sprayer, first determine whether each nozzle is delivering at a uniform rate. Place quart jars under all nozzles and watch as they fill up. The level should rise uniformly and take the same time (within 10%) for all nozzles to fill the jars. Replace any nozzle showing a discharge rate different from the others.

Calibrating the Sprayer

1. Mark off 660 feet (1/8 mile).
2. Fill the tank with water.
3. Set the sprayer to your desired operating pressure.
4. Turn the sprayer on and drive at the constant speed you will be spraying. Calibration on a road or unplowed field will give different results than on soft cultivated ground. Note tachometer reading so same speed can be maintained later.
5. Measure the amount of water it takes to refill the tank completely.
6. Calculate the amount applied:

$$\frac{\text{Number of gallons used} \times 66 \text{ (factor)}}{\text{Spray Swath in Feet}} = \text{Gallons applied per acre}$$

Example: If 10 gallons are used in 660 feet and the spray swath is 40 feet, spraying rate is 16.5 gallons per acre.

$$\frac{10 \times 66}{40} = \frac{660}{40} \text{ or } 16.5 \text{ gallons per acre}$$

7. To calculate the amount of chemical to put in the tank:

$$\frac{\text{Sprayer Tank Size}}{\text{Desired GPA}} = \frac{\text{Acres Covered}}{\text{then;}}$$

$$\frac{\text{Recommended amount of chemical per acre}}{\text{of chemical per acre}} \times \frac{\text{Acres Covered}}{\text{Covered}} = \text{Amount of chemical per tankful}$$

Example: If a 500 gallon tank is used and 16.5 gallons per acre are applied, one tank will cover 30.3 acres. If three pounds of chemical are required per acre, then 90 pounds of chemical is required per tankful.

$$\frac{500}{16.5} = 30.3 \text{ acres covered then;}$$

$$3 \text{ lbs. (gal.)} \times 30.3 = 90 \text{ lbs. (gal.) per tankful}$$

To determine GPA at other nominal speed.

Tractor Speed	Multiply by Speed Factor
4 mph	1.25
5 mph	1.00
6 mph	.83
7.5 mph	.67
10 mph	.50

Sprayer Tips

FLAT SPRAY NOZZLE for Broadcast Spraying

Nozzle No.	Liquid Pressure in PSI	Nozzle Capacity in GPM	Gallons Per Acre Based on 20" Nozzle Spacing			
			4 MPH	5 MPH	7.5 MPH	10 MPH
XR8001VS	20	.07	5.3	4.3	2.8	2.2
	25	.08	5.9	4.7	3.1	2.4
	30	.09	6.4	5.1	3.4	2.6
	40	.10	7.4	6.0	4.0	3.0
XR80015VS	20	.11	7.8	6.3	4.3	3.2
	25	.12	8.8	7.1	4.7	3.6
	30	.13	9.7	7.7	5.2	3.9
	40	.15	11.1	8.9	6.0	4.5
XR8002VS	20	.14	10.5	8.4	5.6	4.2
	25	.16	11.8	9.4	6.3	4.7
	30	.17	12.9	10.3	6.9	5.2
	40	.20	14.8	11.8	7.9	5.9
XR8003VS	20	.21	15.7	12.6	8.4	6.3
	25	.24	17.6	14.1	9.4	7.1
	30	.26	19.0	15.4	10.3	7.7
	40	.30	22.0	17.8	11.8	8.9
XR8004VS	20	.28	21.0	16.8	11.2	8.4
	25	.32	24.0	18.7	12.5	9.4
	30	.35	26.0	21.0	13.7	10.3
	40	.40	30.0	24.0	15.8	11.9
XR8005VS	20	.35	26.0	21.0	14.0	10.5
	25	.40	29.0	23.0	15.7	11.7
	30	.43	32.0	26.0	17.2	12.9
	40	.50	37.0	30.0	19.8	14.9
XR8006VS	20	.42	31.0	25.0	16.9	12.6
	25	.47	35.0	28.0	18.7	14.1
	30	.52	39.0	31.0	21.0	15.5
	40	.60	45.0	36.0	24.0	17.8
XR8008VS	20	.56	42.0	34.0	22.0	17.0
	25	.63	47.0	37.0	25.0	19.0
	30	.69	52.0	41.0	27.0	21.0
	40	.80	59.0	48.0	32.0	24.0
8010SS	20	.70	53.0	42.0	28.0	21.0
	25	.78	59.0	47.0	31.0	24.0
	30	.86	64.0	51.0	34.0	26.0
	40	1.00	74.0	59.0	40.0	30.0

To determine GPA for solutions other than water, determine the weight per gallon or specific gravity and use the following conversion table.

Weight per Gallon	Specific Gravity	Multiply By
7.0 lbs.	.84	1.09
8.0 lbs.	.96	1.02
8.34 lbs. (water)	1.00	1.00
9.0 lbs.	1.08	.96
10.0 lbs.	1.20	.91
11.0 lbs.	1.32	.87
12.0 lbs.	1.44	.83

SPRAYER CHECKLIST:

Downtime caused by field breakdowns is costly and time consuming. Many breakdowns can be eliminated by periodic equipment maintenance. By spending time reviewing this checklist before seasonal spraying application time and following proper after-season care, you can save time and money later.

WARNING: To Prevent Serious Injury Or Death

- Keep hands, feet, and loose clothing away from rotating parts.
- Wear protective clothing recommended by your chemical and fertilizer manufacturer when working with chemicals.

Check Before Going To The Field :

- 1. NOZZLES**
Check tip for excessive wear by checking for grooves in or near tip opening. Check nozzle spacing by starting at center and working outwards. Check boom for proper height.
- 2. HOSES**
Check all hoses for worn or soft spots. Be sure all hose clamps are tightened and hoses are not kinked or pinched. Check for leakage in any lines.
- 3. TANK**
Remove and clean agitator orifices. Check orifices for excessive wear by checking for grooves in or near orifice opening. Inspect fitting and grommets to insure they are in good condition.
- 4. CONTROLS**
Check for leakage, plugging, or wear on all valves, fittings, etc. Clean off any build up of foreign material.
- 5. PUMP**
Check to be sure pump turns freely.
- 6. FRAME**
Be sure all bolts are tightened.
- 7. REPLACEMENT PARTS**
Replace all worn or damaged parts.

After Season Care:

NOTE: It is important to wear proper safety equipment when cleaning the sprayer. See your chemical or fertilizer package for this information.

1. After spraying chemicals, run water mixed with cleaners through tank, pump and all hose hookups. If wettable powder dries out in the system, it is very difficult to put back into suspension and can cause malfunction, damage or injury.
2. When cleaned, tank should have all openings closed or covered to keep dirt from entering.
3. Pump should be flushed with soluble oil and pump ports plugged to keep out moisture and air.
4. Disassemble tips and rinse with water or cleaning solution. (Appropriate for chemical sprayed).
5. Clean tip opening with a wooden toothpick. Never use wire or hard object that could distort opening.
6. Dispose of all unused chemicals or solutions in a proper and ecologically sound manner.
7. Water rinse and dry tips before storing.

NOTE: DEMCO does not and will not make any recommendations concerning application of various chemicals or solutions. These recommendations relate to either amount or procedure of materials applied. If you have any questions regarding application of certain chemicals or solutions, contact your chemical supplier and follow chemical manufacturer recommendations.



P.O. BOX 189
4010 320th St., BOYDEN, IA. 51234
PH: (712) 725-2311
FAX: (712) 725-2380
TOLL FREE: 1-800-54DEMCO (1-800-543-3626)
www.demco-products.com
Go online to www.demco-products.com for Demco
warranty policies & product registration.