

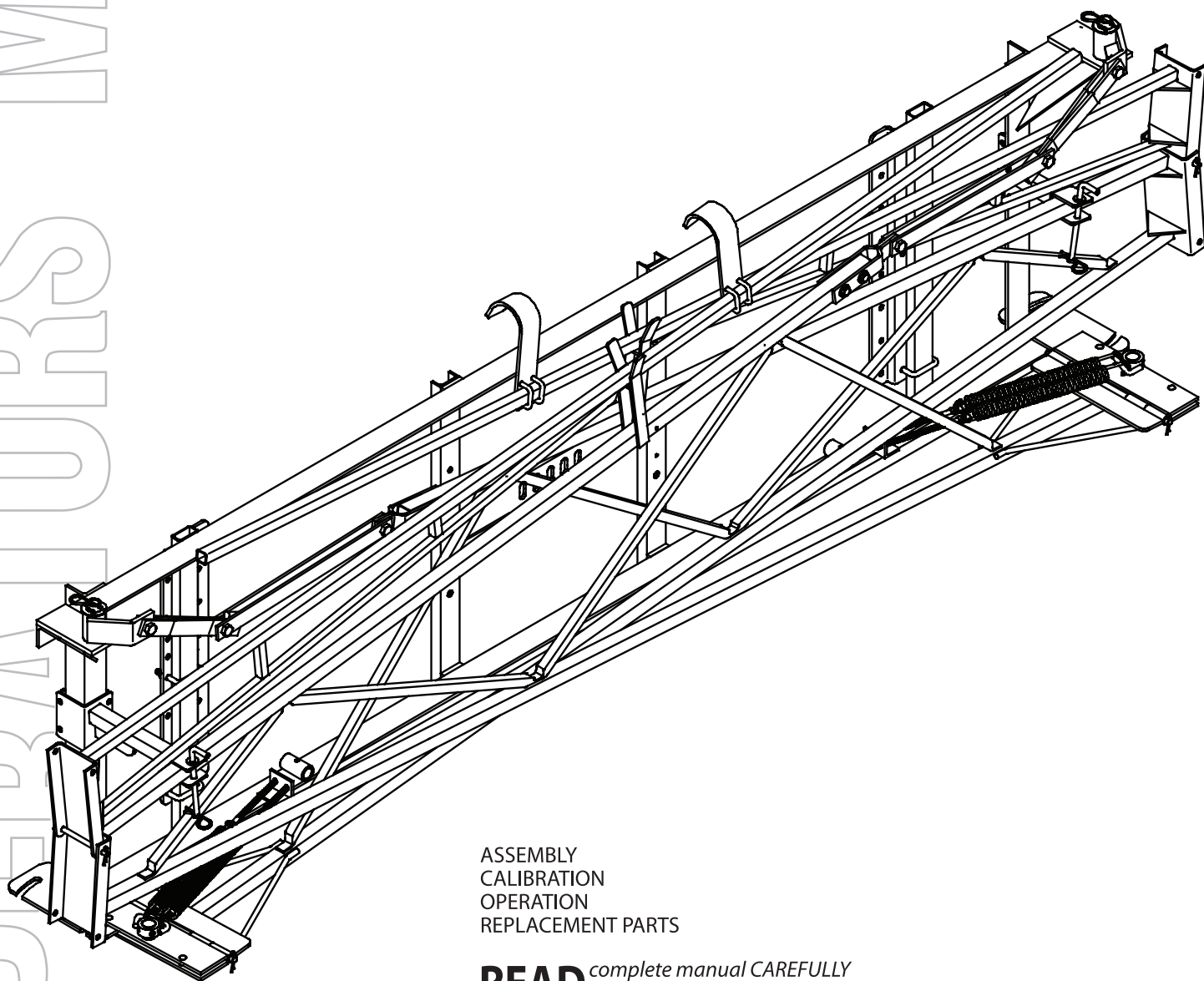

Demco

DTB Truss Boom

28', 30', 40' & 45'



ASSEMBLY
CALIBRATION
OPERATION
REPLACEMENT PARTS

READ *complete manual CAREFULLY
BEFORE attempting operation.*

Doing Our Best To Provide You The Best

MANUAL
OPERATORS

Thank you for purchasing a Demco boom. We feel you have made a wise choice and hope you are completely satisfied with your new flotation boom. If you have any questions regarding the applications of certain solutions or chemicals, contact your chemical supplier and follow chemical manufacturer recommendations as well as all licensing and use restrictions or regulations.

WARRANTY POLICY & REGISTRATION

Go online to www.demco-products.com to review Demco warranty policies and register your Demco product.



WARNING: TO AVOID PERSONAL INJURY OR PROPERTY DAMAGE, OBSERVE THE FOLLOWING INSTRUCTIONS:

Chemicals are dangerous. Know exactly what you're going to do and what is going to happen before attempting to work with these products. Improper selection or use can injure people, animals, plants and soil.

Always wear protective clothing such as coveralls, goggles and gloves when working with chemicals or the sprayer.

Be sure to dispose of all unused chemicals or solutions in a proper and ecologically sound manner.

GENERAL INFORMATION

1. Unless otherwise specified, high-strength (grade 5) (3 radial-line head markings) hex head bolts are used throughout assembly of this piece of equipment.
2. Whenever the terms "**LEFT**" and "**RIGHT**" are used in this manual it means from a position behind the machine and facing forward.
3. When placing a parts order, refer to this manual for proper part numbers and place order by **Part NO. and Description**
4. Be sure rear safety stand is lowered if this sprayer is so equipped. Always lower this stand before unhooking the sprayer from the tractor.

Table of Contents

General information.....	2
Safety , Signal Words.....	3
Equipment Safety Guidelines.....	4
Lighting and Marking.....	4
Safety Sign Care.....	5
Tire Safety.....	5
Remember.....	5
Before Operation.....	6
During Operation.....	6-7
Following Operation.....	8
Highway and Transport Operations.....	8-9
Performing Maintenance.....	9
Bolt Torque.....	10
DB9 Boom Mounts Assembly, Parts Breakdown and PartsList.....	11
9416004 Boom Mounts Assembly, Parts Breakdown and Parts List.....	12
DTB3 Boom Assembly, Parts Breakdown and Parts List.....	13
DTB Boom Assembly, Parts Breakdown and Parts List.....	14 & 15
Auto Level Option Assembly, Parts Breakdown and Parts List.....	16 & 17
DBFT Option Assembly, Parts Breakdown and Parts List.....	18
DMBHA Option Assembly, Parts Breakdown and Parts List.....	19
DMBHAH Option Assembly, Parts Breakdown and Parts List.....	20
DBHY & DBTP Option Assembly, Parts Breakdown and Parts List.....	21
Tip Placement and Nozzle Parts Breakdown and Parts List.....	22
Sprayer Calibration.....	23
Sprayer Checklist.....	24

SAFETY

TAKE NOTE! THIS SAFETY ALERT SYMBOL FOUND THROUGHOUT THIS MANUAL IS USED TO CALL YOUR ATTENTION TO INSTRUCTIONS INVOLVING YOUR PERSONAL SAFETY AND THE SAFETY OF OTHERS. FAILURE TO FOLLOW THESE INSTRUCTIONS CAN RESULT IN INJURY OR DEATH.



THIS SYMBOL MEANS

ATTENTION

BECOME ALERT

YOUR SAFETY IS INVOLVED!

SIGNAL WORDS

Note the use of the following signal words **DANGER**, **WARNING**, and **CAUTION** with the safety messages. The appropriate signal word for each has been selected using the following guidelines:

DANGER:

Indicates an imminently hazardous situation that, if not avoided, will result in death or serious injury. This signal word is to be limited to the most extreme situations typically for machine components which, for functional purposes, cannot be guarded.

WARNING:

Indicates a potentially hazardous situation that, if not avoided, could result in death or serious injury, and includes hazards that are exposed when guards are removed. It may also be used to alert against unsafe practices.

CAUTION:

Indicates a potentially hazardous situation that, if not avoided, may result in minor or moderate injury. It may also be used to alert against unsafe practices.

If you have questions not answered in this manual, require additional copies, or if your manual is damaged, please contact your dealer or Demco, P.O. Box 189, 4010 320th Street, Boyden, IA 51234
ph: (712) 725-2311 Toll Free: 1-800-543-3626 Fax: (712) 725-2380 www.demco-products.com



SAFETY...YOU CAN LIVE WITH IT



EQUIPMENT SAFETY GUIDELINES

Every year many accidents occur which could have been avoided by a few seconds of thought and a more careful approach to handling equipment. You, the operator, can avoid many accidents by observing the following precautions in this section. To avoid personal injury, study the following precautions and insist those working with you, or you yourself, follow them.

In order to provide a better view, certain illustrations in this manual may show an assembly with a safety shield removed. However, equipment should never be operated in this condition. Keep all shields in place. If shield removal becomes necessary for repairs, replace the shield prior to use.

Replace any caution, warning, danger or instruction safety decal that is not readable or is missing. Location of such decals is indicated in this booklet.

Do not attempt to operate this equipment under the influence of alcohol or drugs.

Review the safety instructions with all users annually.

Operator should be a responsible adult. **DO NOT ALLOW PERSONS TO OPERATE OR ASSEMBLE THIS UNIT UNTIL THEY HAVE DEVELOPED A THOROUGH UNDERSTANDING OF THE SAFETY PRECAUTIONS AND HOW IT WORKS.**

To prevent injury or death, use a tractor equipped with a roll over protective system (ROPS). Do not paint over, remove, or deface any safety signs or warning decals on your equipment. Observe all safety signs and practice the instructions on them.

Never exceed the limits of a piece of machinery. If it's ability to do a job, or to do so safely is in question-**DON'T TRY IT.**



LIGHTING AND MARKING

It is the responsibility of the customer to know the lighting and marking requirements of the local highway authorities and to install and maintain the equipment to provide compliance with the regulations. Add extra lights when transporting at night or during periods of limited visibility.

Lighting kits are available from your dealer or from the manufacturer.



SAFETY SIGN CARE

- Keep safety signs clean and legible at all times.
- Replace safety signs that are missing or have become illegible.
- Replaced parts that displayed a safety sign should also display the current sign.
- Safety signs are available from your distributor, dealer parts department, or the factory.

How to install safety signs:

- Be sure that the installation area is clean and dry.
- Decide on the exact position before you remove the backing paper.
- Remove the smallest portion of the split backing paper.
- Align the decal over the specified area and carefully press the small portion with the exposed sticky backing in place.
- Slowly peel back the remaining paper and carefully smooth the remaining portion of the decal into place.
- Small air pockets can be pierced with a pin and smoothed out using the piece of decal backing paper.



TIRE SAFETY

- Failure to follow proper procedures when mounting a tire on a rim can produce an explosion which may result in a serious injury or death.
- Do not attempt to mount a tire unless you have the proper equipment and experience to do the job.
- Inflating or servicing tires can be dangerous. Whenever possible, trained personnel should be called to service and/or mount tires.
- Always order and install tires and wheels with appropriate capacity to meet or exceed the anticipated weight to be placed on the equipment.



REMEMBER

Your best assurance against accidents is a careful and responsible operator. If there is any portion of this manual or function you do not understand, contact your local authorized dealer or the manufacturer.



BEFORE OPERATION:

- Carefully study and understand this manual.
- Do not wear loose-fitting clothing which may catch in moving parts.
- Always wear protective clothing and substantial shoes.
- It is recommended that suitable protective hearing and eye protection be worn.
- The operator may come in contact with certain materials which may require specific safety equipment relative to the handling of such materials. (Examples: extremely dusty, molds, fungus, bulk fertilizers, etc.)
- Keep wheel and lug nuts tightened to specified torque.
- Assure that agricultural implement tires are inflated evenly.
- Give the unit a visual inspection for any loose bolts, worn parts, or cracked welds, and make necessary repairs. Follow the maintenance safety instructions included in this manual.
- Be sure there are no tools lying on or in the equipment
- Do not use the unit until you are sure that the area is clear, especially around children and animals.
- Don't hurry the learning process or take the unit for granted. Ease into it and become familiar with your new equipment.
- Practice operation of your equipment and it's attachments. Completely familiarize yourself and other operators with it's operation before using.
- Make sure that the brakes are evenly adjusted (if equipped with brakes)
- Use a tractor equipped with Roll Over Protection System (ROPS) and fasten your seat belt prior to starting the engine.
- The manufacturer does not recommend usage of a tractor with the ROPS removed.
- Move the tractor wheels to the widest recommended settings to increase stability.
- Securely attach to towing unit. Use a high strength, appropriately sized hitch pin with a mechanical retainer and attach a safety chain.
- Do not allow anyone to stand between the tongue or hitch and the towing vehicle when backing up to the equipment.



DURING OPERATION

- **SAFETY CHAIN** -If equipment is going to be transported on a public highway, a safety chain should be obtained and installed. Always follow state and local regulations regarding safety chain and auxiliary lighting when towing farm equipment on a public highway. Be sure to check with local law enforcement agencies for your own particular regulations. Only a safety chain (not an elastic or nylon/plastic tow strap) should be used to retain the connection between the towing and towed machines in the event of separation of the primary attaching system.

- Install the safety chain by crossing the chains under the tongue and secure to the draw bar cage, hitch, or bumper frame.
- Beware of bystanders, **PARTICULARLY CHILDREN!** Always look around to make sure that it is safe to start the engine of the towing vehicle or move the unit. This is particularly important with higher noise levels and quiet cabs, as you may not hear people shouting.
- **NO PASSENGERS ALLOWED-** Do not carry passengers anywhere on or in the tractor or equipment.
- Keep hands and clothing clear of moving parts.
- Do not clean, lubricate, or adjust your equipment while it is moving.
- When halting operation, even periodically, set the tractor or towing vehicle brakes, disengage the PTO, shut off the engine, and **remove the ignition key.**
- Be especially observant of the operating area and terrain- watch for holes, rocks, or other hidden hazards. Always inspect the area prior to operation.
 - DO NOT operate near the edge of drop-offs or banks.
 - DO NOT operate on steep slopes as overturn may result.
 - Operate up and down (not across) intermediate slopes. Avoid sudden starts and stops.
- Pick the levellest possible route when transporting across fields. Avoid the edges of ditches, gullies, and steep hillsides.
- Be extra careful when working on inclines.
- Periodically clear the equipment of brush, twigs, or other materials to prevent buildup of dry combustible materials.
- Maneuver the tractor or towing vehicle at safe speeds.
- Avoid overhead wires or other obstacles. Contact with overhead lines could cause serious injury or death.
- Avoid loose fill, rocks, and holes; they can be dangerous for equipment operation or movement.
- Allow for unit length when making turns.
- Do not walk or work under raised components or attachments unless securely positioned and blocked.
- Keep all bystanders, pets, and livestock clear of the work area.
- Operate the towing vehicle from the operators seat only.
- Never stand alongside of unit with engine running or attempt to start engine and/or operate machine while standing alongside of unit.
- Never leave running equipment attachments unattended.
- As a precaution, always recheck the hardware on equipment following every 100 hours of operation. Correct all problems. Follow the maintenance safety procedures.



FOLLOWING OPERATION

- Following operation, or when unhitching, stop the tractor or towing vehicle, set the brakes, disengage the PTO and all power drives, shut off the engine and **remove the ignition keys**.
- Store the unit in an area away from human activity.
- Do not park equipment where it will be exposed to livestock for long periods of time. Damage and livestock injury could result.
- Do not permit children to play on or around the stored unit.
- Make sure all parked machines are on a hard, level surface and engage all safety devices.
- Wheel chocks may be needed to prevent unit from rolling.



HIGHWAY AND TRANSPORT OPERATIONS

- Adopt safe driving practices:
 - Keep the brake pedals latched together at all times. **NEVER USE INDEPENDENT BRAKING WITH MACHINE IN TOW, LOSS OF CONTROL AND/OR UPSET OF UNIT CAN RESULT.**
 - Always drive at a safe speed relative to local conditions and ensure that your speed is low enough for an emergency stop to be safe and secure. Keep speed to a minimum.
 - Reduce speed prior to turns to avoid the risk of overturning.
 - Always keep the tractor or towing vehicle in gear to provide engine braking when going downhill. Do not coast.
 - Do not drink and drive!
- Comply with state and local laws governing highway safety and movement of farm machinery on public roads.
- Use approved accessory lighting flags and necessary warning devices to protect operators of other vehicles on the highway during daylight and nighttime transport. Various safety lights and devices are available from your dealer.
- The use of flashing amber lights is acceptable in most localities. However, some localities prohibit their use. Local laws should be checked for all highway lighting and marking requirements.
- When driving the tractor and equipment on the road under 20 mph (40 kph) at night or during the day, use flashing amber warning lights and a slow moving vehicle (SMV) identification emblem.
- Plan your route to avoid heavy traffic.
- Be a safe and courteous driver. Always yield to oncoming traffic in all situations, including narrow bridges, intersections, etc.
- Be observant of bridge loading ratings. Do not cross bridges rated lower than the gross weight at which you are operating.

- Watch for obstructions overhead and to the side while transporting.
- Always operate equipment in a position to provide maximum visibility at all times. Make allowances for increased length and weight of the equipment when making turns, stopping the unit, etc.



PERFORMING MAINTENANCE

- Good maintenance is your responsibility. Poor maintenance is an invitation to trouble.
- Make sure there is plenty of ventilation. Never operate the engine of the towing vehicle in a closed building. The exhaust fumes may cause asphyxiation.
- Before working on this machine, stop the towing vehicle, set the brakes, disengage the PTO and all power drives, shut off the engine and **remove the ignition keys**.
- Be certain all moving parts and attachments have come to a complete stop before attempting to perform maintenance.
- **Always** use a safety support and block wheels. Never use a jack to support the machine.
- Always use the proper tools or equipment for the job at hand.
- Use extreme caution when making adjustments.
- Follow the torque chart in this manual when tightening bolts and nuts.
- Never use your hands to locate a hydraulic leak on attachments. Use a small piece of cardboard or wood. Hydraulic fluid escaping under pressure can penetrate the skin.
- When disconnecting hydraulic lines, shut off hydraulic supply and relieve all hydraulic pressure.
- Openings in the skin and minor cuts are susceptible to infection from hydraulic fluid. **Without immediate medical treatment, serious infection and reactions can occur.**
- Replace **all shields** and guards after servicing and before moving.
- After servicing, be sure all tools, parts and service equipment are removed.
- Do not allow grease or oil to build up on any step or platform.
- Never replace hex bolts with less than grade five bolts unless otherwise specified.
- Refer to bolt torque chart for head identification marking.
- Where replacement parts are necessary for periodic maintenance and servicing, genuine factory replacement parts must be used to restore your equipment to original specifications. The Manufacturer will not claim responsibility for use of unapproved parts and/or accessories and other damages as a result of their use.
- If equipment has been altered in any way from original design, the manufacturer does not accept any liability for injury or warranty.
- A fire extinguisher and first aid kit should be kept readily accessible while performing maintenance on this equipment.

BOLT TORQUE



Checking Bolt Torque

The table shown below gives correct torque values for various bolts and capscrews. Tighten all bolts to the torques specified in chart unless otherwise noted. Check tightness of bolts periodically, using bolt chart as a guide. Replace hardware with the same strength bolt.

NOTE: Unless otherwise specified, high-strength Grade 5 hex head bolts are used throughout assembly of this piece of equipment.



Torque Specifications

Bolt Torque for Standard bolts *

"A"	GRADE 2		GRADE 5		GRADE 8	
	lb-ft	(N.m)	lb-ft	(N.m)	lb-ft	(N.m)
1/4"	6	(8)	9	(12)	12	(16)
5/16"	10	(13)	18	(25)	25	(35)
3/8"	20	(27)	30	(40)	45	(60)
7/16"	30	(40)	50	(70)	80	(110)
1/2"	45	(60)	75	(100)	115	(155)
9/16"	70	(95)	115	(155)	165	(220)
5/8"	95	(130)	150	(200)	225	(300)
3/4"	165	(225)	290	(390)	400	(540)
7/8"	170	(230)	420	(570)	650	(880)
1"	225	(300)	630	(850)	970	(1310)

Bolt Torque for Metric bolts *

"A"	CLASS 8.8		CLASS 9.8		CLASS 10.9	
	lb-ft	(N.m)	lb-ft	(N.m)	lb-ft	(N.m)
6	9	(13)	10	(14)	13	(17)
7	15	(21)	18	(24)	21	(29)
8	23	(31)	25	(34)	31	(42)
10	45	(61)	50	(68)	61	(83)
12	78	(106)	88	(118)	106	(144)
14	125	(169)	140	(189)	170	(230)
16	194	(263)	216	(293)	263	(357)
18	268	(363)	--	--	364	(493)
20	378	(513)	--	--	515	(689)
22	516	(699)	--	--	702	(952)
24	654	(886)	--	--	890	(1206)

Torque figures indicated above are valid for non-greased or non-oiled threads and heads unless otherwise specified. Therefore, do not grease or oil bolts or capscrews unless otherwise specified in this manual. When using locking elements, increase torque values by 5%.

* Torque value for bolts and capscrews are identified by their head markings.

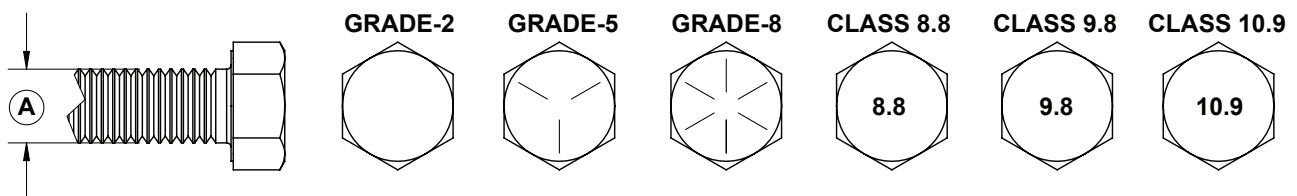

DB9 MOUNTING BRACKETS

Mounting brackets to attach DTB series boom to any trailer frame units without Demco DBFT.

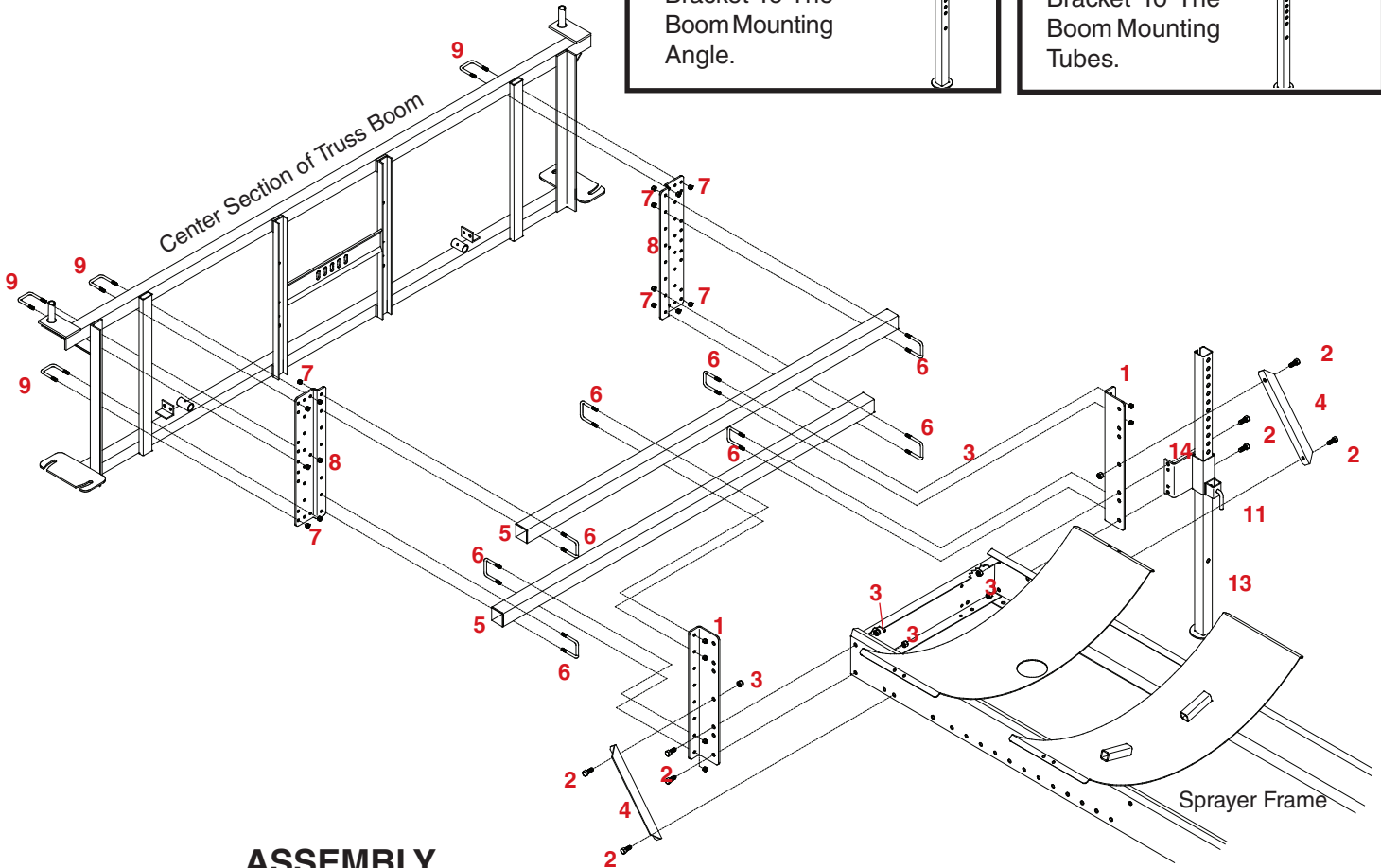
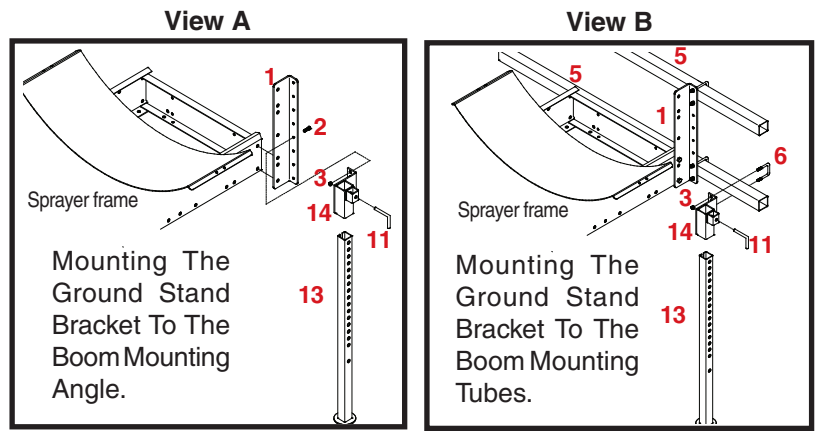

ASSEMBLY

1. Bolt the boom mounting bracket (#1) to the rear of the sprayer frame as shown using four 1/2" x 1-1/4" hex head bolts (#2) and four 1/2" locknuts (#3).

Note: The desired sprayer height should be determined and the boom mounting brackets mounted accordingly.

2. Bolt the mounting brace (#4) to the sprayer frame and the boom mounting bracket (#1) using four 1/2" x 1-1/4" hex head bolts (#2) and four 1/2" lock nuts (#3)

3. Bolt the boom mounting tubes (#5) to the back of the boom mounting brackets with four 3/8" x 2-1/2" x 3-5/16" square U-bolts (#6) and eight 3/8" lock nuts (#7)

4. Adapter plate (#8) should already be mounted to the Center Section of Truss Boom, or see your Boom Manual for the adapter plate mounting instructions.

5. Fasten adapter plate (#8) with center boom section to mounting tubes (#5) with 3/8" x 2-1/2" x 3-5/16" square U-bolts (#6) and 3/8" lock nuts (#7).

6. Install ground stand to preference. See **View A**, **View B** and as shown.

PARTS LIST

REF. NO.	PART NO.	QTY.	DESCRIPTION
1.	01792-76	2	18" Boom Mounting Bracket
2.	00967	8	1/2"-13 UNC x 1-1/4" Hex Head Bolt (Gr.5)
3.	02178	8	1/2"-13 UNC Nylon Insert Lock Nut
4.	02693-76	2	15" Boom Mounting Brace
5.	09602-76	2	2-1/2" sq. x 6' Boom Mounting Tube
6.	01887	9	3/8"-16 UNC x 2-1/2" x 3-5/16" Square U-Bolt
7.	02592	20	3/8"-16 UNC Nylon Insert Lock Nut
8.	*05293-76	-	Adapter Plate
9.	*05294	-	3/8"-16 UNC x 2-1/8" x 2-1/8" Square U-Bolt
10.	00185	1	5/32" x 1" Cotter Pin (not shown)
11.	02187-95	1	Lock Pin
12.	02208	1	Compression Spring (not shown)
13.	05559-76	1	Square Safety Stand
14.	05558-76	1	Safety Stand Holder
15.	00085	8	1/2" Flatwasher (not shown)

* These are not included with DB9 Mounting Brackets, and were included with the Boom Mounting Package.

Please order replacement parts by **PART NO.** and **DESCRIPTION**

9416004 MOUNTING BRACKETS

Mounting bracket to attach any DTB series boom to DEMCO RMS and RML rear mounted three point hitch tank brackets.

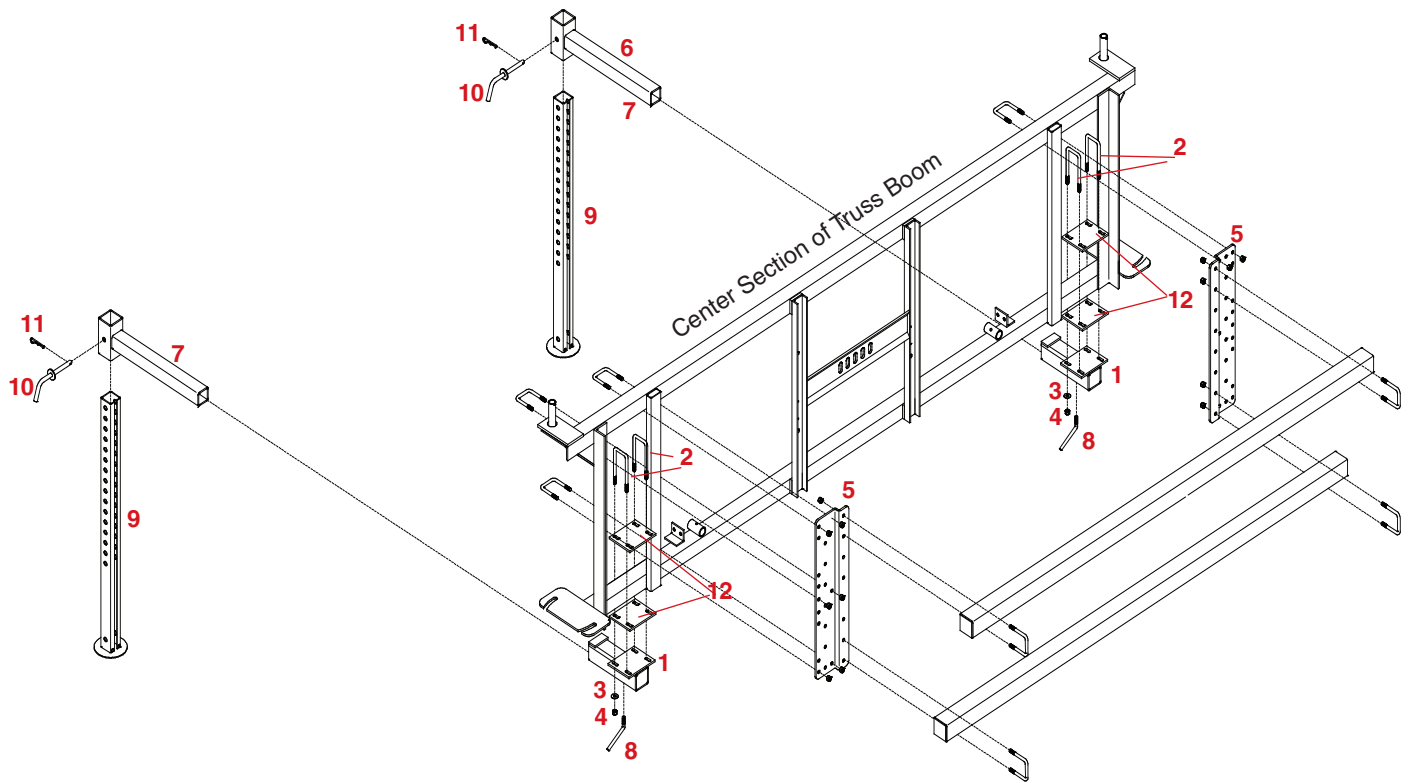

STORAGE STANDS ASSEMBLY INSTRUCTIONS

The Floation Boom Mount and 3-Point Mount must be assembled before proceeding.

1. Mount the Rear Leg Receiver Tube (#1), along with two Adapter Plates(#12) to the bottom of the Center Section using two 3/8" Square U-Bolts (#2), four 3/8" Flatwashers (#3) and four 3/8" Locknuts (#4).
2. Insert the Rear Insert Tube (#7) and secure using a 3/8" Locking Bolt (#8).
3. Insert the Adjustable Legs (#9) and secure using a Locking Pin (#10) and Hair Pin (#11).

Repeat on other side.

PARTS LIST

REF. NO.	PART NO.	QTY.	DESCRIPTION
1.	07650-76	2	Rear Leg Receiver Tube
2.	05583	4	3/8"-16 UNC x 2-1/8" x 4-7/8" Square U-bolt
3.	00059	8	3/8" Flatwasher
4.	02592	12	3/8"-16 UNC Nylon Insert Locknut
5.	*05293-76	2	Adapter Plate
6.	00523	4	3/8"-16 UNC x 1-1/4" Hex Head Bolt (Gr 5)
7.	07651-76	2	Rear Insert Tube
8.	01404-95	2	Locking Bolt
9.	07735-76	4	Adjustable Leg
10.	01718-95	4	Lock Pin
11.	00182	4	.125 Hair Pin
12.	07653-76	4	Back-up Plate

Please order replacement parts by PART NO. and DESCRIPTION.

* These are not included with DB5 Mounting Brackets, and were included with the Boom Mounting Package.

DTB3 MOUNTING BRACKETS

Mounting Brackets to attach DFB series Boom to a tractor's three point hitch

Note: Item #13 is used only with a height adjustor

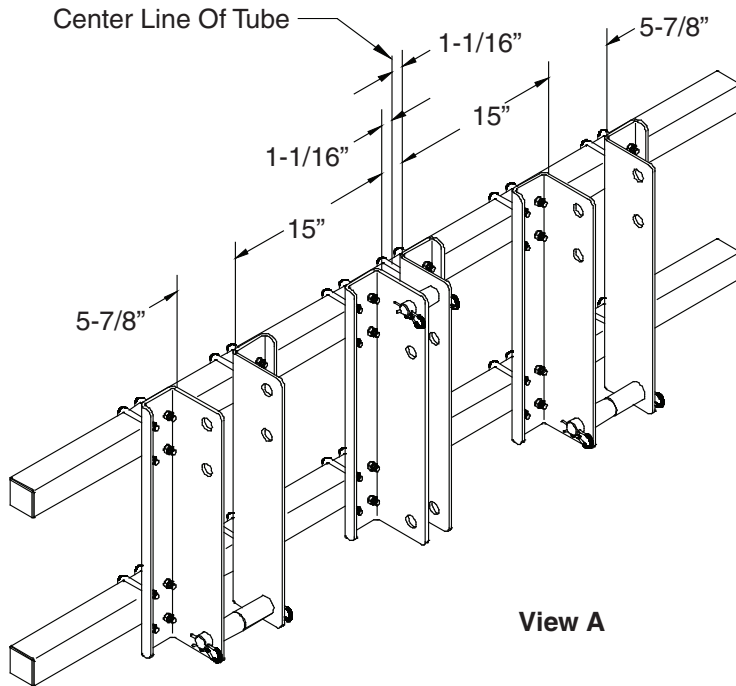
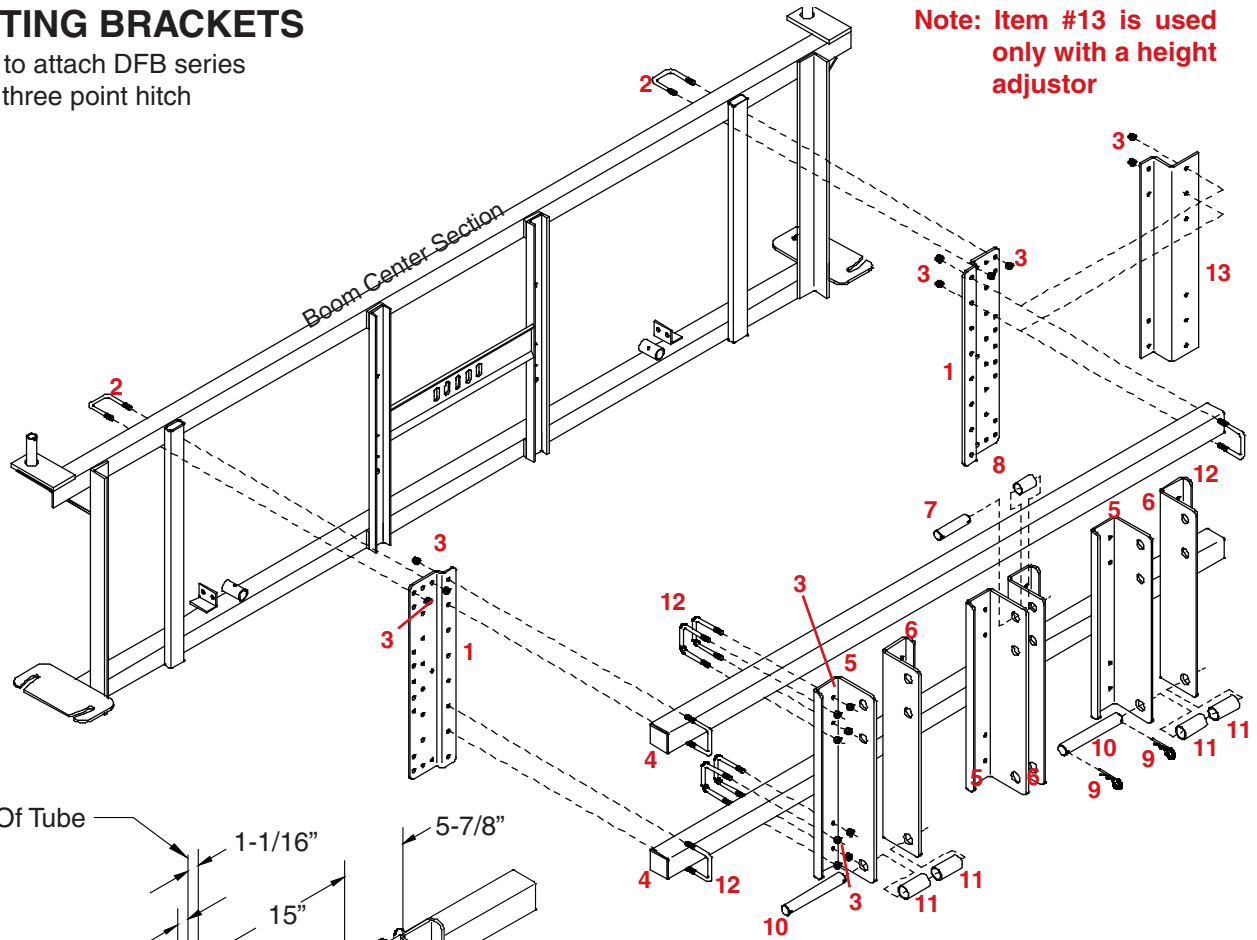

PARTS LIST

REF. PART NO.	NO.	QTY.	DESCRIPTION
1.	*05293-76	2	Adapter Plate
2.	05294	6	3/8" x 2-1/2" Square U-Bolt
3.	02592	64	3/8" Nylon Insert Locknut
4.	09602-76	2	Boom Mounting Tube
5.	05676-76	3	Right Lift Bracket
6.	05675-76	3	Left Lift Bracket
7.	00332-95	1	1" dia. x 4" lg. Lift Pin
8.	05383-95	1	1-1/4" OD X 1" ID X 1-5/16"lg. bushing (Cat III only)
9.	00006	6	5/32" Hair Pin (#9)
10.	05382-95	2	1-1/8" dia. x 7-3/4" lg. Lift Pin
11.	00328-95	4	1-7/16" O.D x 1-3/16" I.D x 2-7/8" lg. Bushing
12.	01887	28	3/8" x 2-1/2" x 3-5/16" Square U-bolt
13.	04974-76	2	Adapter Plate

Please order replacement parts by PART NO. and DESCRIPTION

*These are not included with DTB3 Mounting Brackets, and were included with the Boom Mounting Package.

ASSEMBLY

1. Fasten Adapter Plate (#1) to the Boom Center Section using four 3/8"-16 UNC x 2-1/8" x 2-1/8" square U-bolts (#2), and eight 3/8"-16 UNC nylon insert lock nuts (#3).

2. Fasten right and left lift brackets (#5) and (#6) to the boom carrier tubes (#4) with the 3/8" x 2-1/2" x 3-5/16" square U-bolts (#12) and 3/8" lock nuts (#3). **NOTE:** Position one set on each end and in the center of the boom mounting tubes (#4), do not tighten bolts at this time. See above **View A** for dimensions for mounting the brackets.

3. The Spray height should be determined at this time. Fasten the boom mounting tube (#4) to the adapter plate (#1) with the 3/8" x 2-1/2" x 3-5/16" square U-bolts (#12) and 3/8" locknuts.

4. Connect the tractor's center stabilizer arm to the center lift brackets by inserting lift pin (#7) through centers of lift bracket (#5), (Cat. II will require bushing (#8)), tractor center lift arm and center lift bracket (#6). Insert hair pin (#9) through both ends of lift pin (#7). Tighten all bolts for center lift brackets.

5. Adjust the outside lift arm brackets in or out to properly fit your tractor.

6. Connect the tractor's outside lift arms to the lift brackets by inserting lift pin (#10) through lift bracket (#5), bushing (#11), tractor lift arm and lift bracket (#6). Insert a hair pin (#9) through both ends of lift pin (#10). Tighten all bolts.

DTB BOOM ASSEMBLY AND PARTS LIST

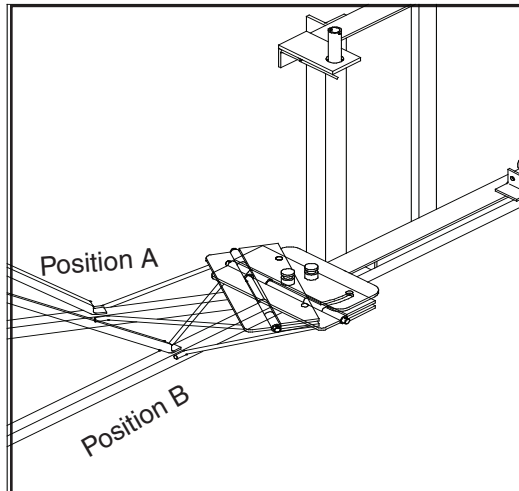

ASSEMBLY INSTRUCTIONS

1. After the Boom Center Section (#5) is mounted in the desired manner, couple the boom wing by inserting one peg of the wing hinge into the slot of the center section hinge (Position A above).
2. Straighten the boom wing so the opposite peg of the wing hinge goes into the opposite slot of the center section hinge (Position B above). NOTE: Add grease or oil to the boom break-away hinge to help the breaking action of the boom.
3. Connect the level adjustment plates (#6) to the boom wing using two 3/8" x 2-1/2" Hex Head Bolts (#7), two 3/8" Flatwashers (#8) and two 3/8" Nylon Insert Locknuts (#9).
4. Connect the Long Linkage Bracket (#12) to the level adjustment plates (#6) using a 1/2" x 1-3/4" Hex Head Bolt (#10) and a 1/2" Nylon Insert Locknut (#11).
5. Connect the Short Linkage Bracket (#13) to the Long Linkage Bracket (#12) using a 1/2" x 1-3/4" Hex Head Bolt (#10) and a 1/2" Nylon Insert Locknut (#11).
6. Connect the Short Linkage Bracket (#13) to the Boom Wing Swivel (#14) using a 1/2" x 1-3/4" Hex Head Bolt (#10) and a 1/2" Nylon Insert Locknut (#11). NOTE: These bolts must not be overtightened. The linkage must move freely.
7. Lift the Boom Wing assembly and slide the Boom Swivel (#14) onto the peg on the Boom Center Section (#5).
8. Lay the machine washer (#15) on top of the Boom Wing Swivel (#14) and insert the Hair Pin (#16).
9. Make sure the Boom Wing (#4) is level with the Boom Center Section (#5) and tighten the Level Adjustment Plates (#6) to the Boom Wing. The linkages must allow

the wing to move freely up and return to level.

10. Install the Break-away Spring Hook Collar (#17) over the peg on the wing hinge and lock into place with the 3/8" x 1" Hex Head Bolt (#20) and 3/8" Hex Nut (#21). **NOTE:** The collar must be able to rotate around the peg, therefore do not over tighten the 3/8" bolt.
11. Hook one end of the Break-Away Springs (#18) onto the collar (#17). Hook the other ends through the 3/8" x 6" tension bolts (#19). Insert the tension bolts through the angle on the Boom Center Section (#5) and secure with a 3/8" Nylon Insert Locknut (#9). Tighten the 3/8" nuts until the desired break-away tension is reached.
12. Connect the Boom Extension (#24, #25 or # 26) to the boom wing (#4) using Hinge Pin (#22) and Cotter Pin (#3) in the top hole in the hinge. Insert the Removable Pin (#23) in the bottom hole and secure with Hairpin (#16). NOTE: The removable pin is also used in the storage brackets.
13. Bolt on the Tip Protector (#27) using two 5/16" U-Bolts (#28) and four 5/16" Nylon Insert Locknuts (#29)

PARTS LIST

REF. NO.	PART NO.	QTY.	DESCRIPTION
-	5030-10	2	Boom Wing Assembly
1.	05503-10	2	Wing Hinge
2.	05502	2	Wing Hinge Pin (1/2" x 12-3/4" Long)
3.	00009	4	1/8" x 1" Cotter Pin
4.	05501-10	2	Boom Wing
5.	05508-10	1	Boom Center Section
6.	00169 -76	4	Level Adjustment Plate
7.	00082	4	3/8"-16 UNC x 2-1/2" Hex Head Bolt (Gr.5)
8.	00059	8	3/8" Flatwasher
9.	02592	28	3/8"-16 UNC Nylon Insert Locknut
10.	00482	6	1/2"-13 UNC x 1-3/4" Hex Head Bolt (Gr. 5)
11.	02178	6	1/2"-13 UNC Nylon Insert Locknut
12.	00170-76	2	Long Linkage Bracket
13.	00171-76	2	Short Linkage Bracket
14.	05505-76	2	Boom Wing Swivel
15.	00175	2	Machine Bushing (1-3/8" x 14 Ga NR)
16.	00182	4	Hair Pin
17.	00176-95	2	Spring Hook Collar
18.	00180 -76	4	Break Away Spring
19.	00178	4	3/8"-16 UNC x 6" Tension Bolt
20.	00907	2	3/8"-16 UNC x 1" Hex Head Bolt (Gr. 5)
21.	00061	2	3/8"-16 UNC Hex Nut
22.	00340 -95	2	Boom Extension Hinge Pin
23.	00183-95	2	Removable Extension Hinge Pin
24.	02784-10	2	30' Boom Extension
25.	00184-10	2	40' Boom Extension
26.	00339 -10	2	45' Boom Extension
27.	05297-76	2	"J" Style Tip Protector
28.	00909	4	5/16"-18 UNC x 1-1/4" x 1-3/4" Square U-Bolt
29.	02802	8	5/16"-18 UNC Nylon Insert Locknut
30.	02765-76	1	Long Boom Storage Bracket
31.	02766-76	1	Short Boom Storage Bracket
32.	00523	8	3/8"-16 UNC x 1-1/4" Hex Head Bolt (Gr. 5)
33.	02767-76	2	Boom Storage Bracket Back-Up Plate
34.	05293-76	2	Boom Mounting Plate
35.	05294	6	3/8"-16 UNC x 2-1/8" x 2-1/8" Square U-Bolt

Please order replacement parts by PART NO. and DESCRIPTION.

DTB BOOM ASSEMBLY AND PARTS BREAKDOWN

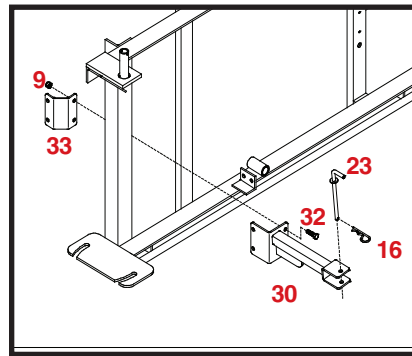
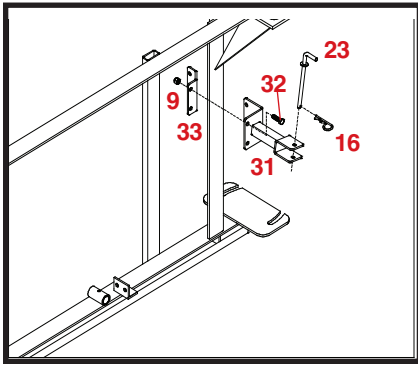

14. Mount the Long Storage Bracket (#30) on the left side of the Boom Center Section (#5) using four 3/8" x 1-1/4" Hex Head Bolts (#32), Back-Up Plate (#33) and four 3/8" Nylon Insert Locknuts (#9).

15. Mount the Short Storage Bracket (#31) on the right side of the Boom Center Section (#5) using four 3/8" x 1-1/4" Hex Head Bolts (#32), Back-Up Plate (#33) and four 3/8" Nylon Insert Locknuts (#9). **NOTE:** Final adjustment can be made later.

Repeat Steps 1 through 13 for opposite side of boom.

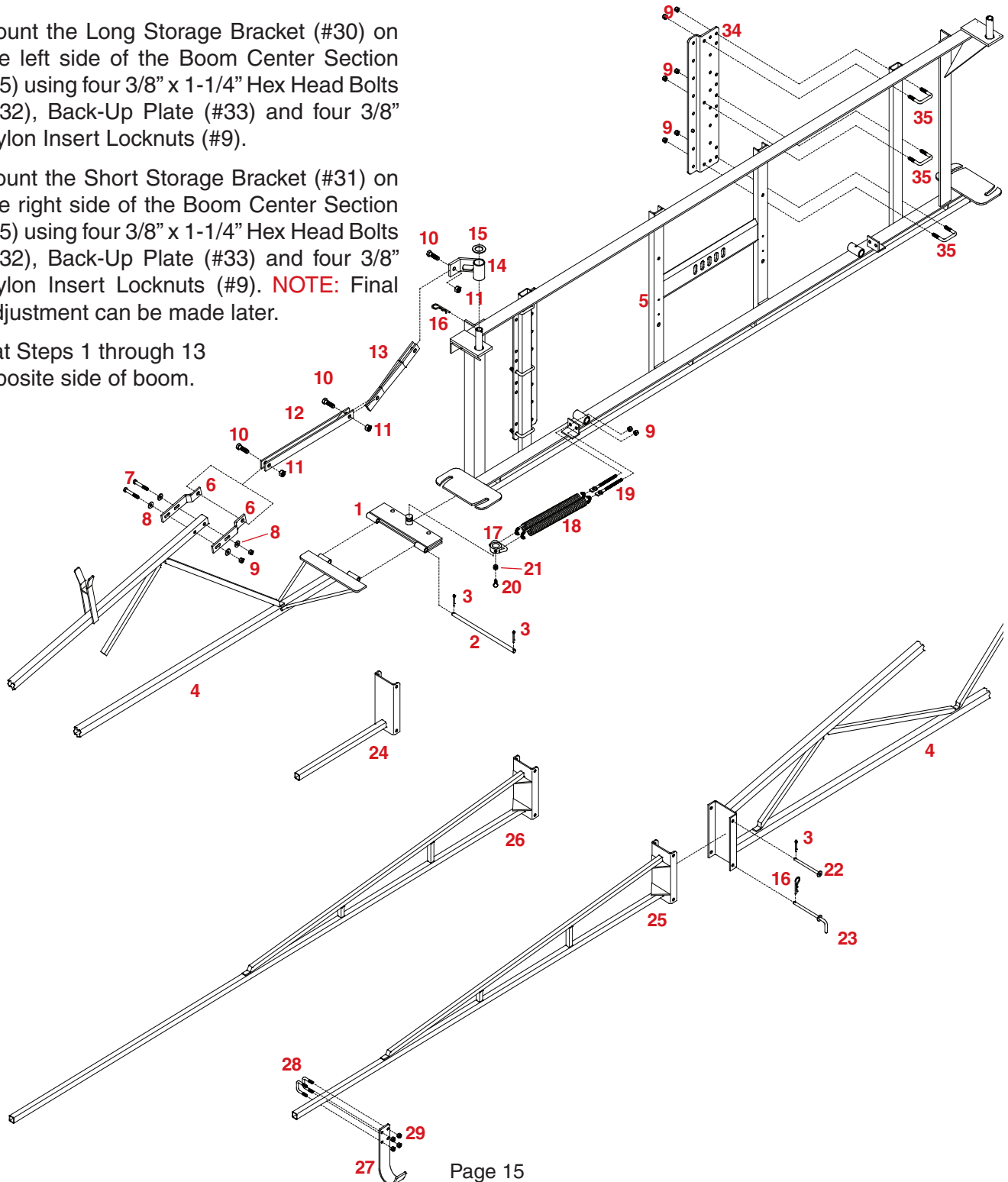

Mounting Bracket Assembly

1. Attach the Auto-Level Boom Mounting Plate (#1) to the Boom Mounting Tubes (A) or the DBFT (B) as shown. NOTE: Be sure the bolt spacing is 69".
2. Mount one Boom Hanger (#2) to each of the Boom Mounting Plates (#1) using two 3/8" x 1-1/2" Bolts (#3) and two 3/8" Nylon Insert locknuts (#4).

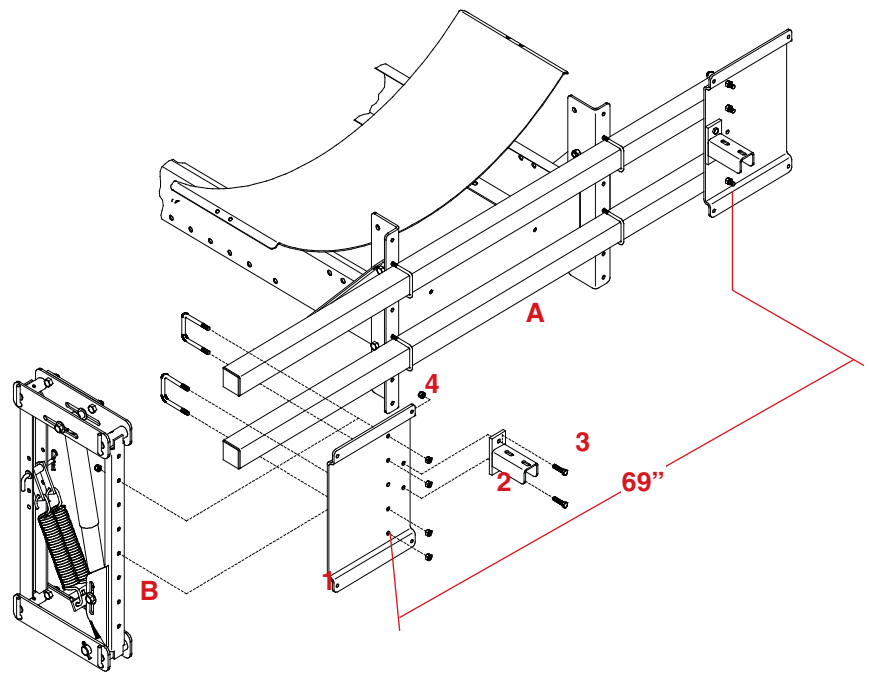

Center Section Assembly

3. Attach two Short Wear Strips (#6) to the Boom Center Section (#5) using four 1/4" x 1/2" Flat Head Screws. Attach one Short Wear Strip (#6) to each Boom Guide (#8) using two 1/4" x 1/2" Flat Head Screws. Bolt the Boom Guides (#8) to the Center Section (#5) using a 3/8" x 1-1/4" Bolt (#22) and a 3/8" Nylon Insert locknut (#4) through the bottom hole of the boom guide.

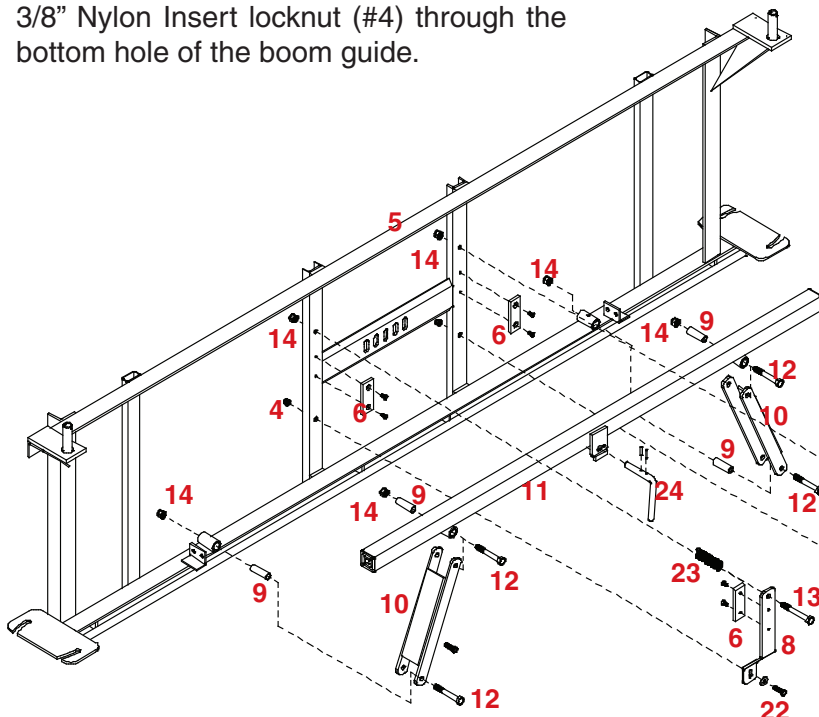

inside the Boom Guides (#8) and attach the bottom of the Swing Links (#10) to the Boom Center Section (#5) using a 1/2" x 3-1/2" Bolts (#12) and a 1/2" Nylon Insert Locknut (#14).

8. Attach the top of each Boom Guide (#8) to the Center Section (#5) using a 1/2" x 4" Bolt (#13) and 1/2" Nylon Insert Locknut (#14). Remember to run Bolt (#13) through Tension Spring (#23). **DO NOT OVERTIGHTEN BOLT (#13).**

9. Grease the zerks at each pivot point of the swing links.

4. Install the Swing Lock Pin (#24) in the Boom Hanger Tube (#11) as shown.
5. Push the Inner Swivel Bushings (#9) into the pivot points on the Center Section (#5) and the Boom Hanger Tube (#11).
6. Attach the top of the Swing Links (#10) to the Boom Hanger Tube (#11) using a 1/2" x 3-1/2" Bolts (#12) and a 1/2" Nylon Insert Locknut (#14).
7. Set the Boom Hanger Tube Assembly (#11)

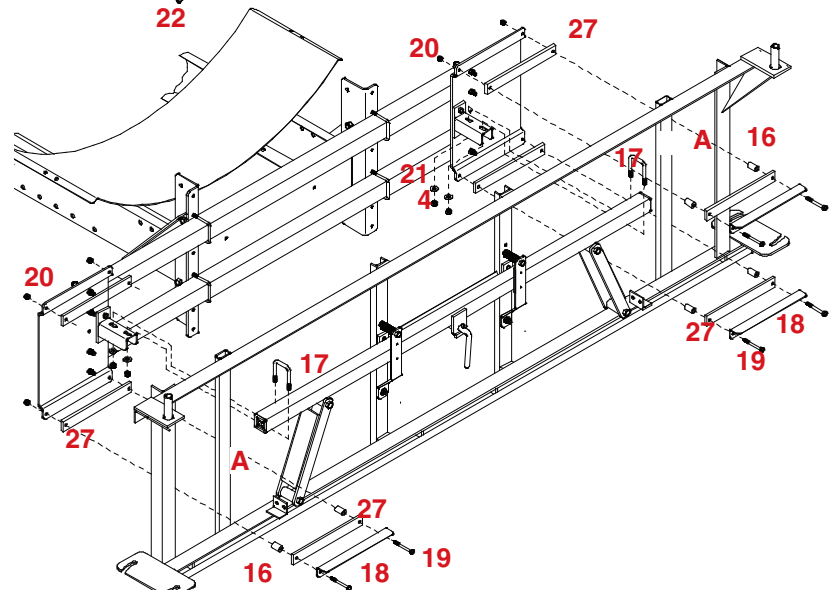

AUTO-LEVEL OPTION PARTS LIST, ASSEMBLY AND PARTS BREAKDOWN

PARTS LIST

Mounting the Center Section

NOTE: Make sure the Swing Lock Handle (#24) is in the latched position.

10. Begin by centering the Boom Hanger Tube assembly onto the hanger brackets (#2). Secure the hanger tube to the hanger brackets using two 3/8" x 2" Square U-Bolts (#17), four 3/8" Flatwashers (#21) and four 3/8" Nylon Insert Locknuts (#4). **Do Not tighten these at this time.**
11. Attach the support angles (#18), Wear Plates (#15) and Spacer Bushings (#16) using eight 5/16" x 3" Bolts (#19) and eight 5/16" Nylon Insert Locknuts (#20).
12. Adjust the Boom Center Section in or out to center tube (A) between the wear strips by sliding the hanger tube on the hanger bracket. Tighten the u-bolts after adjustment.
13. Adjust the tension of the sway guides (#8). The guides should be tight enough to limit the play of the center section frame but still allow boom to swing freely. This should be set with complete boom assembled.

REF. NO.	PART NO.	QTY.	DESCRIPTION
1.	02950-76	2	Boom Mounting Plate
2.	02943-76	2	Boom Hanger Mount
3.	00914	4	3/8"-16 UNC x 1-1/2" Hex Head Bolt (Gr.5)
4.	02592	12	3/8"-16 UNC Nylon Insert Locknut
5.	05508-10	1	Boom Center Section
6.	03324	8	Short Wear Strip
7.	02206	8	1/4"-20 UNC x 1/2" Flat Head Screw
8.	02945-76	2	Boom Guide
9.	02944-95	4	Inner Swivel Bushing
10.	02941-76	2	Swing Link
11.	02942-76	1	Boom Hanger Tube
12.	01897	4	1/2"-13 UNC x 3-1/2" Hex Head Bolt (Gr.5)
13.	01896	2	1/2"-13 UNC x 4" Hex Head Bolt (Gr.5)
14.	02178	2	1/2"-13 UNC Nylon Insert Locknut
15.	02948-95	8	Spacer Bushing
16.	02128	2	3/8"-16 UNC x 2" x 3" Square U-Bolt
17.	02947-76	4	Boom Support Angle
18.	04224	8	5/16"-18 UNC x 3" Hex Head Bolt (Gr.5)
19.	02802	8	5/16"-18 UNC Nylon Insert Locknut
20.	00059	6	3/8" Flatwasher
21.	00523	2	3/8"-16 UNC x 1-1/4" Hex Head Bolt (Gr.5)
22.	01348-30	2	Boom Swing Tension Spring
23.	02951-95	1	Boom Swing Lock Pin
24.	02583	1	3/16" x 1-1/4" Roll Pin
25.	03099	1	3/16" x 1" Roll Pin
26.	04193	2	2" Square Cap Plug
27.	02949	8	Long Wear Strip

Please order replacement parts by PART NO. and DESCRIPTION.

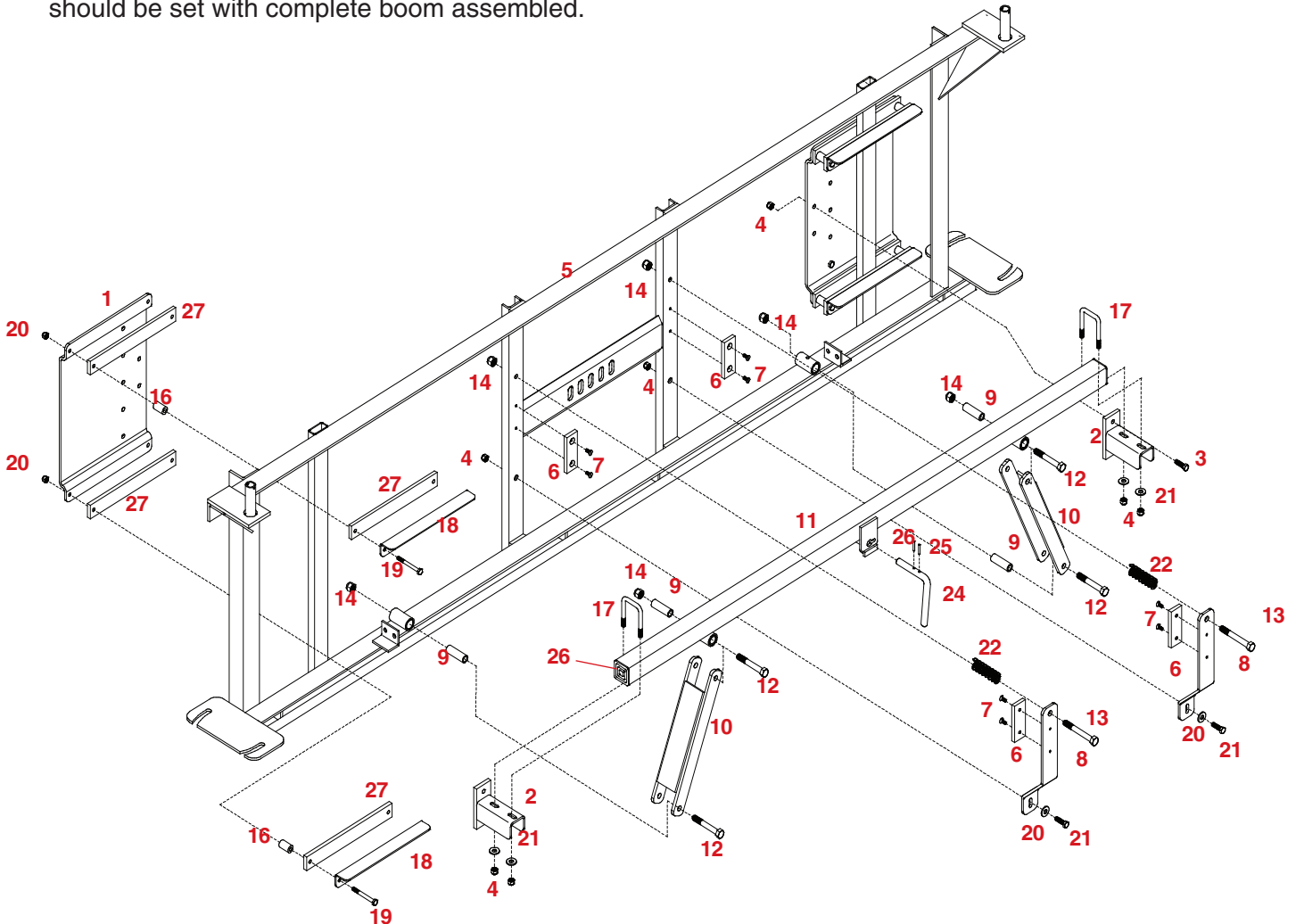

DBFT BOOM CARRIER ASSEMBLY AND PARTS BREAKDOWN

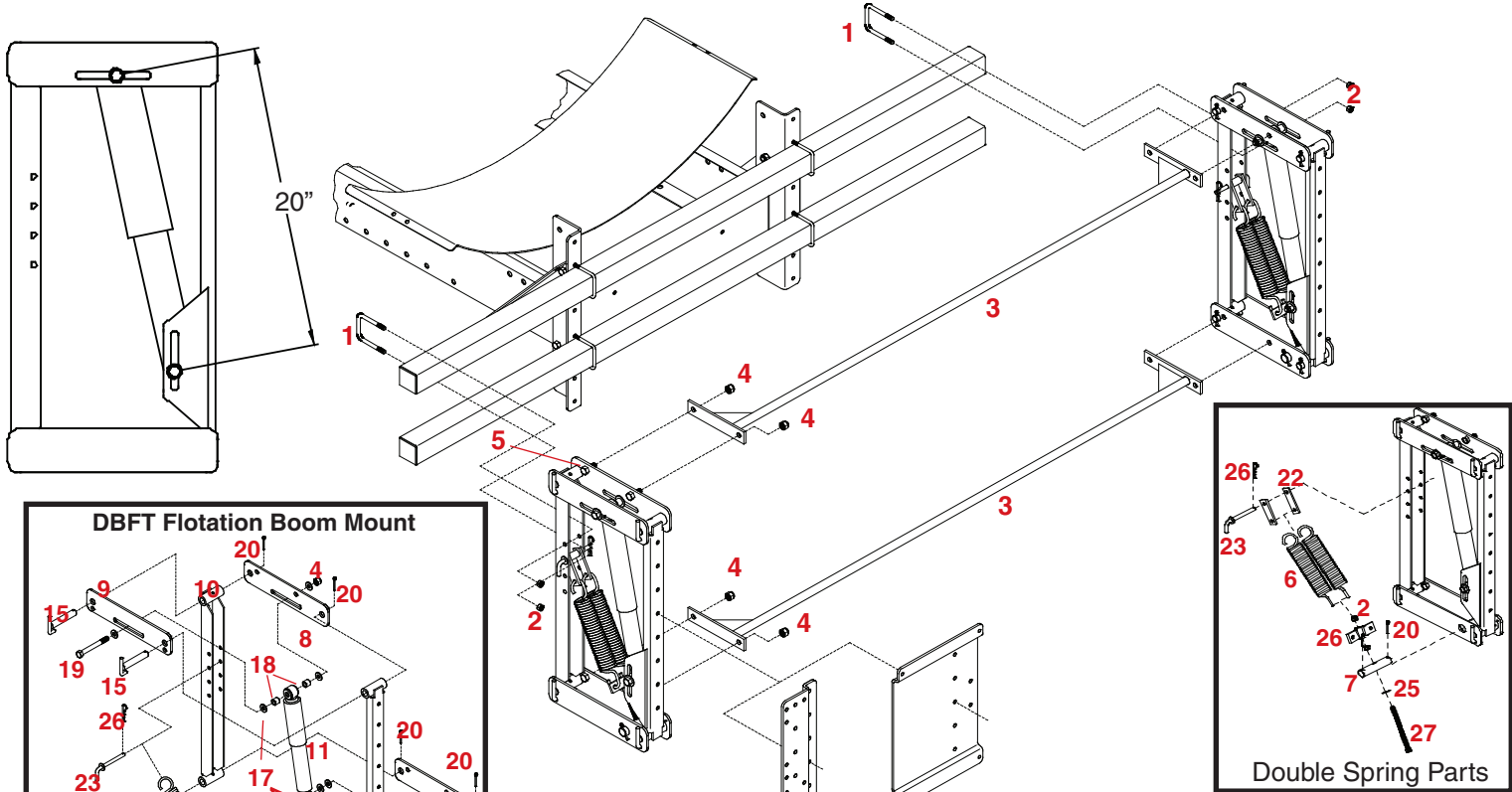

DBFT ASSEMBLY INSTRUCTIONS

- Begin by connecting the upper plate (#9) and upper torsion plate (#8) to the front carrier channel (#10) and the rear floating channel (#12) using the connecting pins (#15).
- Use cotter pin (#20) to retain the connecting pins.
- Bolt the shock absorber (#11) to the rear floating channel (#12) as shown using the 1/2" x 3-1/2" bolt (#16), six 1/2" flatwashers (#17) and 1/2" nylon insert locknut (#4).
- Fasten the shock absorber to the upper plates using the two shock spacers (#18), 1/2" x 4-1/2" bolt (#19), four 1/2" flatwashers (#17), and 1/2" hex nut (#4).
- Connect the lower plate (#14) and lower torsion plate (#13) to the front carrier channel (#10) and the rear channel (#12) using the connecting pins (#15). **NOTE: The lower plates are not both the same and must be installed as shown for left-hand assembly (opposite for right side).**
- Slide the spring anchor pin (#7) through the hole in the lower plates (#13 & 14), using cotter pins (#20) to retain the spring anchor pin.
- Insert spring pin (#23) to the front carrier channel (#10) and secure it with hair pin. Hook one end of the springs (#6) to the pin (#23) and the other end through the tension bolt (#21) and insert it through the spring anchor pin (#7) and fasten with a 3/8" flatwasher and 3/8" locknut.

ASSEMBLY INSTRUCTIONS

- Attach the DBFT Flotation Boom Mount to each end of the Boom Carrier Tubes, using four 3/8"-16 UNC x 2-1/2" U-bolts (#1) and eight 3/8" locknuts (#2).
- Mount the Torsion Bars (#3) to the DBFT Mounts on both sides, top and bottom using eight 1/2" x 1-1/4" bolts (#5) and eight 1/2" locknuts (#4) as shown.
- Mount the appropriate adaptor plate to the DBFT mounts as shown.

PARTS LIST

REF. NO.	PART NO.	QTY.	DESCRIPTION
1.	01887	4	3/8"-16 UNC x 2-1/2" U-bolt
2.	02592	10	3/8"-16 UNC Nylon Insert Locknut
3.	00201-76	2	Torsion Bars
4.	02178	12	1/2"-13 UNC Nylon Insert Locknut
5.	00967	8	1/2"-13 UNC x 1-1/4" Hex Head Bolt
6.	00200-30	4	Spring
7.	00198-95	2	Spring Anchor Pin
8.	00187-76	2	Upper Parallel Torsion Plate
9.	00186-76	2	Upper Parallel Plate
10.	00188-76	2	Front Carrier Channel
11.	00192-76	2	Shock Absorber
12.	00189-76	2	Rear Floating Channel
13.	00197-76	2	Lower Parallel Torsion Plate
14.	00196-76	2	Lower Parallel Plate
15.	00190-95	8	Connecting Pin
16.	01897	2	1/2"-13 UNC x 3-1/2" Hex Head Bolt
17.	00085	20	1/2" Flatwasher
18.	00193-95	4	Shock Spacers
19.	01338	2	1/2"-13 UNC x 4-1/2" Hex Head Bolt Gr.5
20.	00191	12	Cotter Pin
21.	00178	2	Single Spring Tension Bolt
22.	02967-95	4	Spring Mounting Plate (option)
23.	00199-95	2	Pin
24.	00059	2	3/8" Flatwasher
25.	00182	2	Small Hair Pin
26.	07836-95	2	Spring mount
27.	00675	2	Spring Tension Bolt

Please order replacement parts by
PART NO. and DESCRIPTION.

MANUAL HEIGHT ADJUST (DMBHA) OPTION

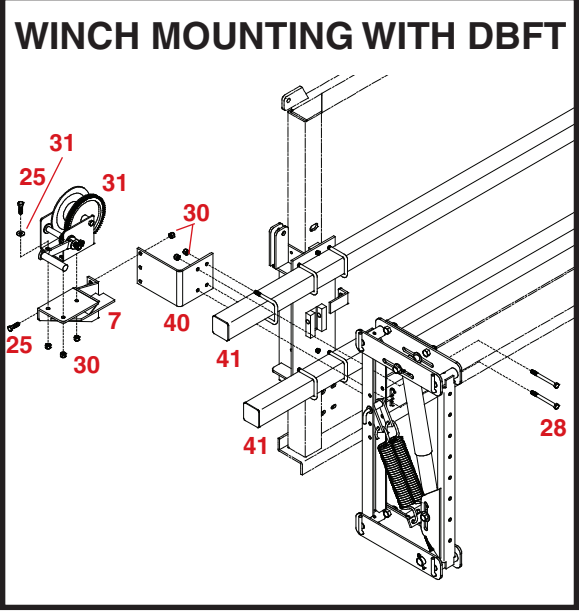
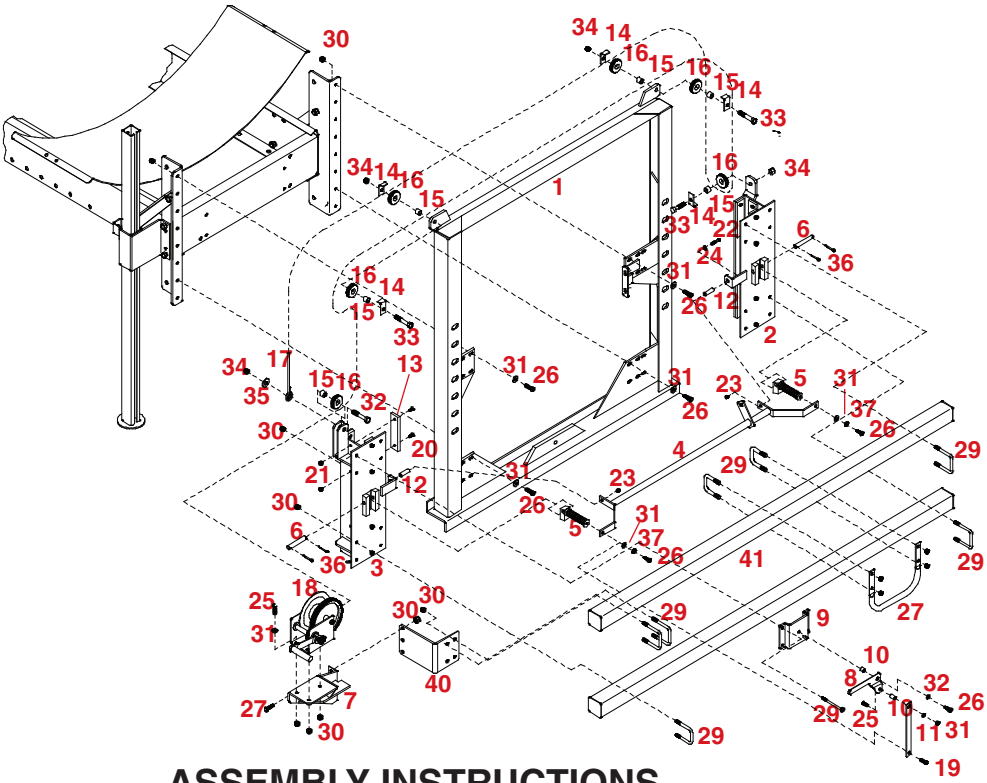

ASSEMBLY INSTRUCTIONS

- Mount the height adjust frame (#1) to the boom mounting brackets on sprayer frame using eight 3/8" x 1-1/4" bolts, eight 3/8" flatwashers, and eight 3/8" locknuts. Note: The mounting brackets may need to be turned in or out depending on sprayer frame width.
- Attach twelve UHMW strips (#13) to the left and right slide brackets (#2 & #3) using twenty-four 1/4" x 1" slotted head screws (#20), and twenty-four 1/4" locknuts(#21).
- On the right slider bracket attach pulley (#16) using spacer (#15), cable retainer bracket (#14), 1/2" x 2-1/2" bolt (#33), and 1/2" locknut (#34). Slide left and right slider brackets (#2 & #3) onto the mainframe (#1). Next install both latches (#5) onto slider brackets using pins (#6), and four cotter pins (#36). Slide each slider bracket up until latches fall into first slot (be sure both latches are in the same slot on each upright).
- Attach the latch actuator (#4) to the slider brackets using two 5/16" x 1-1/2" bolts (#22), two bushings (#12), two 5/16" flatwashers (#24), and two 5/16" locknuts (#23). Attach boom carrier tubes to the slider brackets using six 3/8" x 2-1/2" Sq. U-bolts (#29), and twelve 3/8" locknuts (#30).
- Mount the manual latch handle (#8) to the manual latch plate (#9), and the link strip (#11) using two 3/8" x 1" bolts (#25), two bushings (#10), three 3/8" flatwashers (#31), and two 3/8" locknuts (#30). Install this assembly to the boom carrier and left slider plate (#3) using four 3/8" x 3-1/2" bolts (#28), and four 3/8" locknuts (#30). Now insert a 3/8" x 1-3/4" bolt (#19) thru the link strip (#11) and latch actuator (#4) to the left latch (#5). On the right use a 3/8" x 1-1/4" bolt (#26) thru the latch actuator (#4) to the right latch (#5).
- Mount the hose keeper (#27) to the upper tube of the boom carrier using two 3/8" x 2-1/2" Sq. U-bolts (#29), and four 3/8" locknuts (#30). Attach winch mount (#7) to the offset bracket (#40) using three 3/8" x 1 1/4" bolts(#26), and three 3/8" locknuts(#30). Mount this assembly to the boom carrier tubes using two 3/8" x 2-1/2" Sq. u-bolts(#29) and four 3/8" locknuts(#30).
NOTE: When using DBFT, substitute two 3/8" x 3-1/2" Bolts for one U-bolt. Mount the winch to the winch assembly using three 3/8" x 1-1/4" bolts(#26), three 3/8"flatwashers(#31), and three 3/8" locknuts(#30).
- Mount four pulleys (#16) on the top of the the mainframe (#1) using two 1/2" x 2-1/2" bolts(#33), two spacers (#15), four cable retainer brackets (#14), and two 1/2" locknuts (#34). On the left slider bracket attach pulley (#16), and cable assembly (#17) using spacer (#15), 1/2" x 2-1/2" bolt (#33), 1/2" flatwasher (#35), and 1/2" locknut (#34).
- Route cable as shown and fasten to winch.

(DMBHA) MANUAL HEIGHT ADJUST PARTS LIST

REF. NO.	PART NO.	QTY.	DESCRIPTION
1.	07841-76	1	Frame
2.	07843-76	1	Right Slide Bracket
3.	07842-76	1	Left Slide Bracket
4.	07844-76	1	Latch Actuator
5.	07846-76	2	Latch
6.	07851-95	2	Latch Pin
7.	07916-76	1	Winch Mount
8.	07917-76	1	Manual Latch
9.	07918-76	1	Manual Latch Plate
10.	07919-95	2	Bushing 1/2" O.D x 18 Ga. WL. x 5/16" Lg.
11.	07920-95	1	Link Strip
12.	01212-95	2	Bushing 1/2" O.D. x 5/16" I.D. x 5/8" Lg.
13.	03324	12	UHMW Strip
14.	01838-95	5	Cable Retainer Bracket
15.	00193-95	6	Spacer
16.	01840-95	6	Pulley
17.	05611	1	20' Cable Assembly
18.	04967	1	Winch
19.	00511	1	3/8"-16 UNC x 1-3/4" Hex Head Bolt
20.	05732	24	1/4"-20 UNC x 1" Slotted Flat Head
21.	02772	24	1/4"-20 UNC Nylon Insert Locknut
22.	00372	2	5/16"-18 UNC x 1-1/2" Hex Head Bolt
23.	02802	2	5/16"-18 UNC Nylon Insert Locknut
24.	00004	2	5/16" Flatwasher
25.	00907	4	3/8"-16 UNC x 1" Hex Head Bolt
26.	00523	18	3/8"-16 UNC x 1-1/4" Hex Head Bolt
27.	07852-76	1	Hose Keeper
28.	01903	6	3/8"-16 UNC x 3-1/2" Hex Head Bolt
29.	01887	10	3/8"-16 UNC x 2-1/2" Sq. U-bolt
30.	02592	46	3/8"-16 UNC Nylon Insert Locknut
31.	00059	14	3/8" Flatwasher
32.	01253	1	1/2"-13 UNC x 2" Hex Head Bolt
33.	01264	3	1/2"-13 UNC x 2-1/2" Hex Head Bolt
34.	02178	4	1/2"-13 UNC Nylon Insert Locknut
35.	00085	1	1/2" Flatwasher
36.	00191	4	Cotter Pin 3/16" x 1-1/2"
37.	00060	2	3/8" Lock washer
38.	01792-76	2	Boom Mounting Brackets(not included)
40.	07943-76	1	Offset Bracket
41.	04930-76	2	Boom Carrier Tube

HYDRAULIC HEIGHT ADJUST (DMBHAH) OPTION

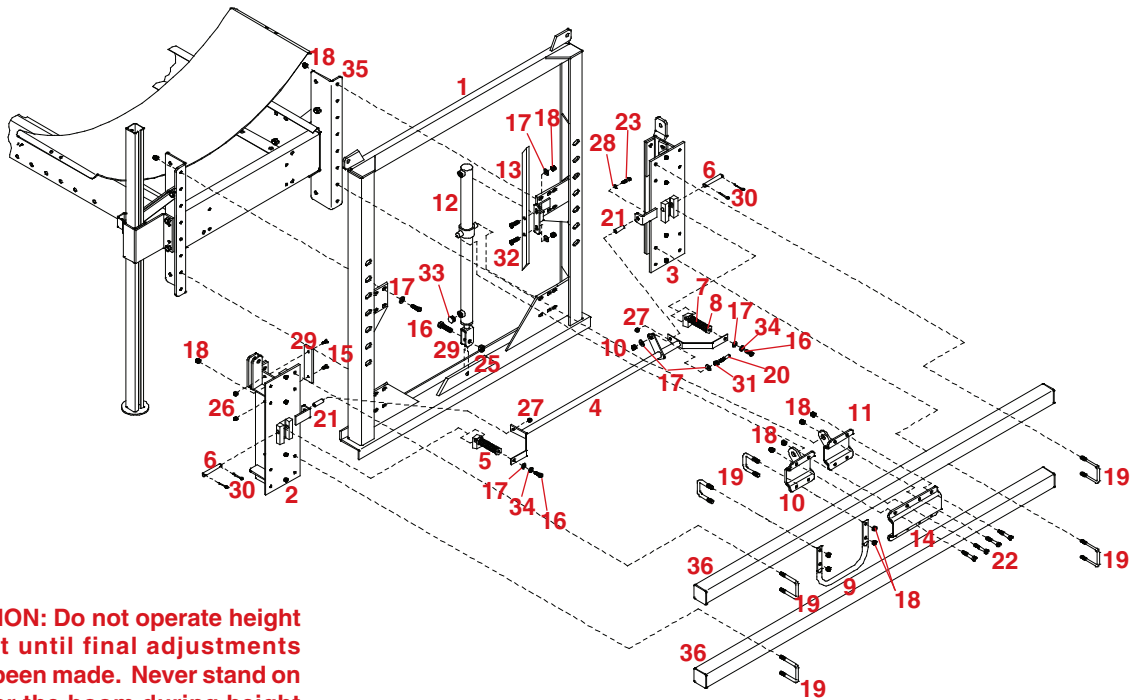

CAUTION: Do not operate height adjust until final adjustments have been made. Never stand on or near the boom during height adjust operation.

Use CAUTION when adjusting height. Make sure all air is bled from the line before initial trial.

ASSEMBLY INSTRUCTIONS

1. Mount the height adjust frame (#1) to the boom mounting brackets on sprayer frame using eight 3/8" x 1-1/4" bolts(#16), eight 3/8" flatwashers(#17), and eight 3/8" locknuts(#18).
2. Attach twelve UHMW plastic strips (#29) to the left and right slide brackets (#2 & #3) using twenty-four 1/4" x 1" slotted head screws (#15), and twenty-four 1/4" locknuts (#26).
Do Not Overtighten.
3. Install both latches (#5) onto slider brackets using pins (#6), and four cotter pins (#30). Slide left and right slider brackets (#2 & #3) onto the mainframe (#1). Slide each slider bracket up until latches fall into first slot (be sure both latches are in the same slot on each upright). C-clamp into position.
4. Attach the latch actuator (#4) to the slider brackets using two 5/16" x 1-1/2" bolts (#23), two bushings (#21), two 5/16" flatwashers (#28), and two 5/16" locknuts (#27). Attach boom carrier tubes(#36) to the slider brackets using eight 3/8" x 2-1/2" Sq. U-bolts (#19), and sixteen 3/8" locknuts (#18).
5. Attach latch actuator (#4) to latches using two 3/8" x 1-1/4" bolts (#16), two lock washers(#34) and two 3/8" flatwashers (#17). Mount slide bar (#13), in high position, to frame (#1) using two 3/8" x 1-1/2" bolts (#32), two 3/8" flatwashers (#17), and two 3/8" locknuts (#18). Install slide guide stud (#20) to latch actuator (#4) using two flatwashers (#17), one 3/8" hex nut (#31), and one 3/8" locknut (#18) to back of slot. Mount the hose keeper (#9) to the upper tube of the boom carrier tubes(#36) using two 3/8" x 2-1/2" Sq. U-bolts (#19), and four 3/8" locknuts (#18).
6. Mount cylinder (#12) to the frame (#1) using 1/2" x 2" bolt (#24), and 1/2" locknut (#25). Attach cylinder to the boom carrier tubes (#36) using left and right cylinder mounts (#10 & #11), and cylinder mount backup plate (#14), eight 3/8" x 2-1/4" bolts(#22), and eight 3/8" locknuts (#18). Mounts should be centered.
7. Install air vent (#33) to bottom of cylinder with hole down to keep water out.

REF. NO.	PART NO.	QTY.	DESCRIPTION
1.	07841-76	1	Frame
2.	07843-76	1	Right Slide Bracket
3.	07842-76	1	Left Slide Bracket
4.	07844-76	1	Latch Actuator
5.	07846-76	2	Latch Assembly (includes #7 & #8)
6.	07851-95	2	Latch Pin
9.	07852-76	1	Hose Keeper
10.	07848-76	1	Left Cylinder Mount
11.	07849-76	1	Right Cylinder Mount
12.	05600-30	1	Cylinder
13.	07845-76	1	Slide Bar
14.	07850-76	1	Cylinder Mount Backup Plate
15.	05732	24	1/4"-20 UNC x 1" Slotted Flat Head Screw
16.	00523	10	3/8"-16 UNC x 1-1/4" Hex Head Bolt
17.	00059	14	3/8" Flatwasher
18.	02592	39	3/8"-16 UNC Nylon Insert Locknut
19.	01887	10	3/8"-16 UNC x 2-1/2" Sq. U-bolt
20.	07854-95	1	Slide Guide Stud
21.	01212-95	2	Bushing 1/2" O.D. x 5/16" I.D. x 5/8" Lg.
22.	02494	8	3/8"-16 UNC x 2-1/4" Hex Head Bolt
23.	00372	2	5/16"-18 UNC x 1-1/2" Hex Head Bolt
24.	01253	1	1/2"-13 UNC x 2" Hex Head Bolt
25.	02178	1	1/2"-13 UNC Nylon Insert Locknut
26.	02772	24	1/4"-20 UNC Nylon Insert Locknut
27.	02802	2	5/16"-18 UNC Nylon Insert Locknut
28.	00004	2	5/16" Flatwasher
29.	03324	12	UHMW Strip
30.	00191	4	Cotter Pin
31.	00061	1	3/8"-16 UNC Hex Nut
32.	00914	2	3/8"-16 UNC x 1-1/2" Hex Head Bolt
33.	00288	1	Air Vent - Hydraulic Cylinder
34.	00060	2	3/8" Lock Washer
35.	01792-76	2	Boom Mounting Brackets(not included)
36.	04930-76	2	Boom Carrier Tube
-	5222	-	Cylinder Repair Kit for 05600-30

Please order replacement parts by PART NO. and DESCRIPTION.

(OPTIONAL) HYDRAULIC BOOM LEVELING PARTS BREAKDOWN

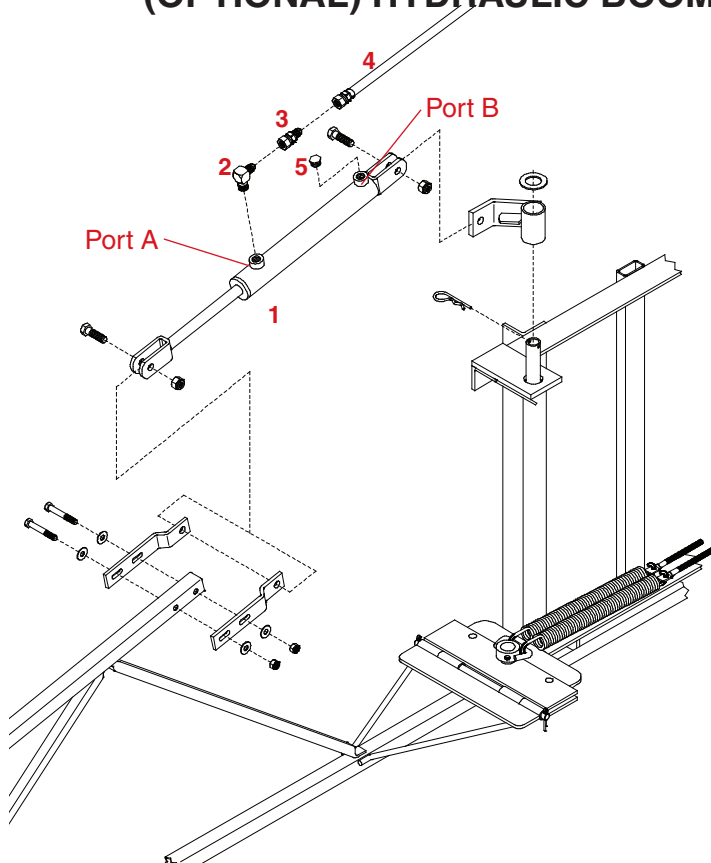

NOTE: After the cylinders are installed, the booms should lower about one foot and raise about three feet.



INSTALLATION

CAUTION: If this is being installed on an existing boom, the boom must be unfolded and each wing supported before proceeding.

1. Remove the offset linkage. Using the existing bolts (see pages 4 & 5) mount the hydraulic cylinder (#1) in place of the linkages as shown. **NOTE:** The cylinder rod must be connected to the wing and the gland end connected to the swivel on the center section.
2. Install the 3/8" Street elbow (#2) to the port on the rod end (port A) of the hydraulic cylinder (#1). Turn in the air vent (#5) into the port on the gland end (port B) of the hydraulic cylinder (#1). Turn in the orifice fitting (#3) into the street elbow (#2). Attach the hydraulic hose (#4) to the orifice fitting (#3).

DFHY PARTS LIST

REF. NO.	PART NO.	QTY	DESCRIPTION
1.	00286-30	2	Hydraulic Cylinder
2.	05215	2	3/8" Steel Elbow Fitting
3.	05661	2	3/8" MPT x 3/8" FPT Orifice Restrictor
4.	05013	2	26' Hydraulic Hose
5.	00288	2	Air Vent
-	5222	-	Cylinder Repair Kit

Please order replacement parts by **PART NO.** and **DESCRIPTION.**

(OPTIONAL) WHEEL TIP PROTECTOR PARTS BREAKDOWN

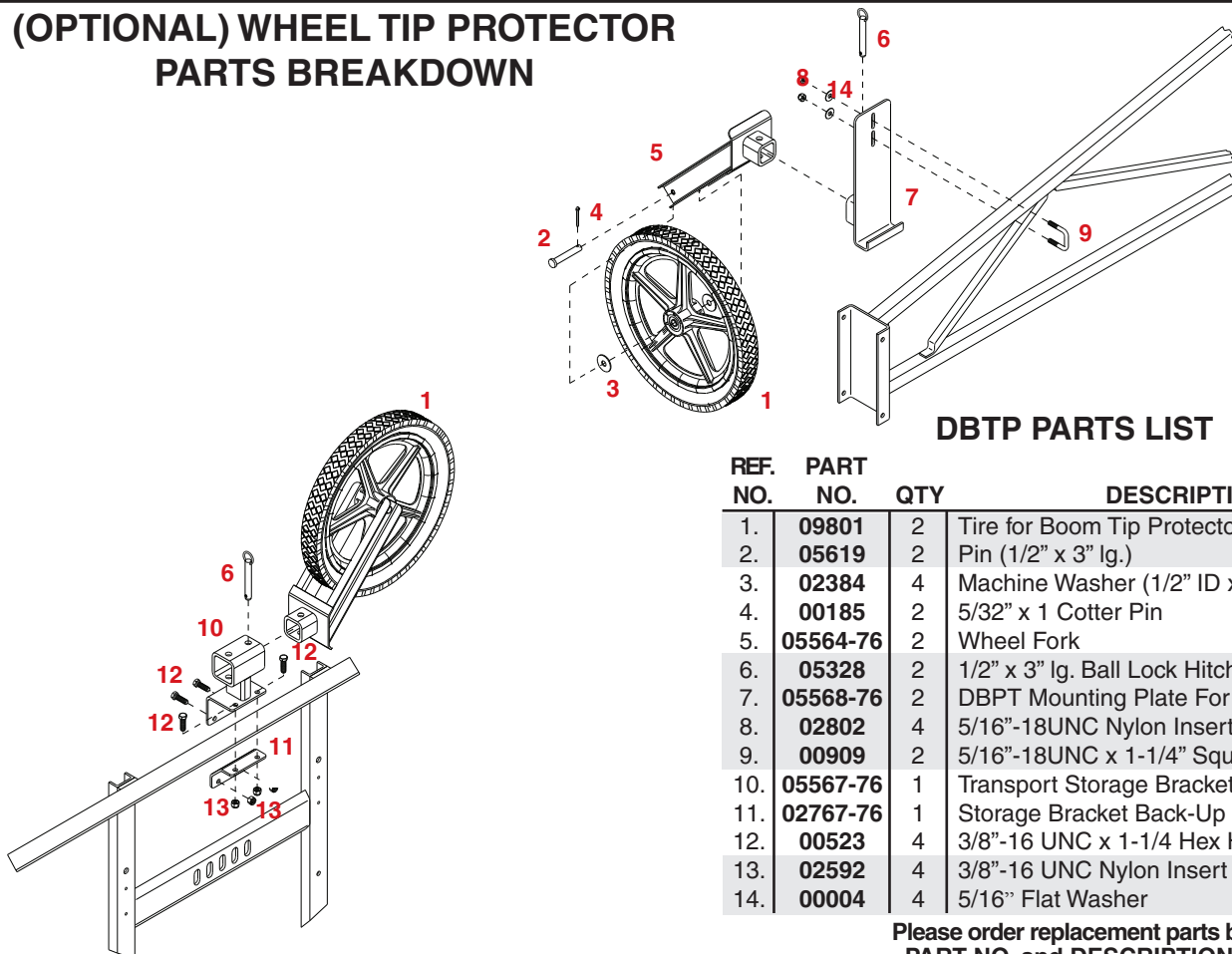

DBTP PARTS LIST

REF. NO.	PART NO.	QTY	DESCRIPTION
1.	09801	2	Tire for Boom Tip Protectors
2.	05619	2	Pin (1/2" x 3" lg.)
3.	02384	4	Machine Washer (1/2" ID x 14 GA.)
4.	00185	2	5/32" x 1 Cotter Pin
5.	05564-76	2	Wheel Fork
6.	05328	2	1/2" x 3" lg. Ball Lock Hitch Pin
7.	05568-76	2	DBPT Mounting Plate For Wing
8.	02802	4	5/16"-18UNC Nylon Insert Locknut
9.	00909	2	5/16"-18UNC x 1-1/4" Square U-bolt
10.	05567-76	1	Transport Storage Bracket
11.	02767-76	1	Storage Bracket Back-Up Plate
12.	00523	4	3/8"-16 UNC x 1-1/4 Hex Head Bolt (Gr 5)
13.	02592	4	3/8"-16 UNC Nylon Insert Locknut
14.	00004	4	5/16" Flat Washer

Please order replacement parts by **PART NO.** and **DESCRIPTION.**

TIP PLACEMENT

1. **Marking location of boom clamps:** Mark the clamp locations by starting at the center of the center boom section. From this mark, locate 20 inch spaces to both ends of the boom.

NOTE:28' Boom 17 Tips
 30' Boom... 19 Tips
 40' Boom...25 Tips
 45' Boom...27 Tips

2. **Fasten preassembled boom lines:** Fasten the boom clamps (#3) on the boom so the sprayer tip will be on the back side of the left boom wing and the center section and on the front of the right boom wing, (when standing in the back of the sprayer), to prevent the tips from breaking off when the boom wings are folded into transport position.

NOTE: The 28 and 30 foot booms on the Demco sprayers are 1-1/4 inch tubing. The wing extensions for the 40 and 45 foot booms are 1 inch tubing. Therefore, these booms will have two different size clamps.

BASIC PLUMBING PARTS LIST

REF. NO.	PART NO.	DESCRIPTION
-	340RB	3/4" Rubber Hose
-	B12H	3/4" Gear Clamp
-	NHT11	Nylon Hose Ties

Please order replacement parts by PART NO. and DESCRIPTION.

NOTE: Feeder line is not included when boom is ordered separately

CONVENTIONAL NOZZLES AND BOOM CLAMPS

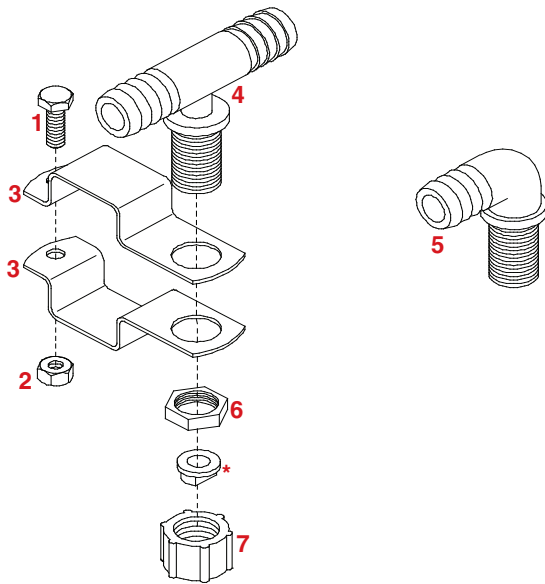

1" & 1-1/4" BOOM CLAMP PARTS LIST

REF. NO.	PART NO.	DESCRIPTION
-	B11 1	1" Boom Clamp Assembly
-	B11 114	1-1/4" Boom Clamp Assembly
1.	00068	1/4"-20UNC x 3/4" Hex Head Bolt
2.	00062	1/4"-20UNC Hex Nut
3.	00337-95	1-1/4" Boom Clamp
-	00338-95	1" Boom Clamp

3/4" NOZZLE PARTS LIST

REF. NO.	PART NO.	DESCRIPTION
4.	NTT34	3/4" Nozzle Tee
5.	NLT34	3/4" Nozzle Elbow
6.	B12	Nut
*	-----	Tip (specify tip size) (not included)
7.	8027	11/16" FPS Cap

Please order replacement parts by PART NO. and DESCRIPTION.

TEEJET NOZZLES AND BOOM CLAMPS

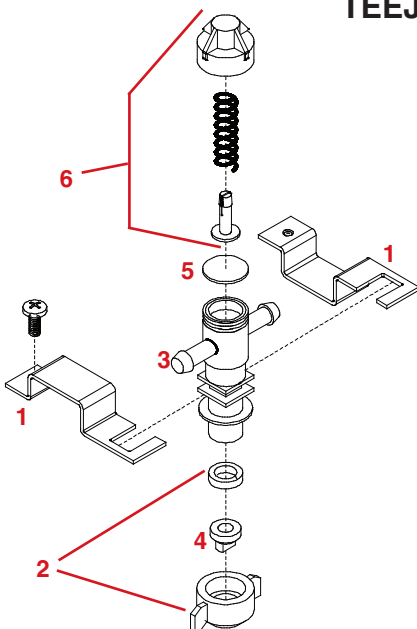

3/4" NOZZLE PARTS LIST

REF. NO.	PART NO.	DESCRIPTION
1.	07786	1-1/2" Sq. Boom Clamp (includes bolt)
2.	07787	Flat Fan Cap (includes EPDM Gasket)
3.	09147	3/4" TeeJet Nozzle Elbow
-	09148	3/4" TeeJet Nozzle Tee
4.	-----	Tip (specify tip size) (not included)
5.	21953VI	Diaphragm (viton)
6.	21950 10PP	End Cap Assembly

Please order replacement parts by PART NO. and DESCRIPTION.

SPRAYER CALIBRATION PROCEDURES

NOTE: To avoid wind drift, use lower pressure and higher spray volume.

Guidelines For Sprayer Calibration

Before calibrating your sprayer, first determine whether each nozzle is delivering at a uniform rate. Place quart jars under all nozzles and watch as they fill up. The level should rise uniformly and take the same time (within 10%) for all nozzles to fill the jars. Replace any nozzle showing a discharge rate different from the others.

Calibrating the Sprayer

1. Mark off 660 feet (1/8 mile).
2. Fill the tank with water.
3. Set the sprayer to your desired operating pressure.
4. Turn the sprayer on and drive at the constant speed you will be spraying. Calibration on a road or unplowed field will give different results than on soft cultivated ground. Note tachometer reading so same speed can be maintained later.
5. Measure the amount of water it takes to refill the tank completely.
6. Calculate the amount applied:

$$\frac{\text{Number of gallons used} \times 66 \text{ (factor)}}{\text{Spray Swath in Feet}} = \text{Gallons applied per acre}$$

Example: If 10 gallons are used in 660 feet and the spray swath is 40 feet, spraying rate is 16.5 gallons per acre.

$$\frac{10 \times 66}{40} = \frac{660}{40} \text{ or } 16.5 \text{ gallons per acre}$$

7. To calculate the amount of chemical to put in the tank:

$$\frac{\text{Sprayer Tank Size}}{\text{Desired GPA}} = \frac{\text{Acres Covered}}{\text{then;}}$$

$$\text{Recommended amount of chemical per acre} \times \frac{\text{Acres Covered}}{\text{Amount of chemical per tankful}} =$$

Example: If a 500 gallon tank is used and 16.5 gallons per acre are applied, one tank will cover 30.3 acres. If three pounds of chemical are required per acre, then 90 pounds of chemical is required per tankful.

$$\frac{500}{16.5} = 30.3 \text{ acres covered then;}$$

$$3 \text{ lbs. (gal.)} \times 30.3 = 90 \text{ lbs. (gal.) per tankful}$$

To determine GPA at other nominal speed.

Tractor Speed	Multiply by Speed Factor
4 mph	1.25
5 mph	1.00
6 mph	.83
7.5 mph	.67

Sprayer Tips

FLAT SPRAY NOZZLE for Broadcast Spraying

Nozzle No.	Liquid Pressure in PSI	Nozzle Capacity in GPM	Gallons Per Acre Based on 20" Nozzle Spacing			
			4 MPH	5 MPH	7.5 MPH	10 MPH
XR8001VS X	20	.07	5.3	4.3	2.8	2.2
	25	.08	5.9	4.7	3.1	2.4
	30	.09	6.4	5.1	3.4	2.6
	40	.10	7.4	6.0	4.0	3.0
XR80015VS X	20	.11	7.8	6.3	4.3	3.2
	25	.12	8.8	7.1	4.7	3.6
	30	.13	9.7	7.7	5.2	3.9
	40	.15	11.1	8.9	6.0	4.5
XR8002VS X	20	.14	10.5	8.4	5.6	4.2
	25	.16	11.8	9.4	6.3	4.7
	30	.17	12.9	10.3	6.9	5.2
	40	.20	14.8	11.8	7.9	5.9
XR8003VS X	20	.21	15.7	12.6	8.4	6.3
	25	.24	17.6	14.1	9.4	7.1
	30	.26	19.0	15.4	10.3	7.7
	40	.30	22.0	17.8	11.8	8.9
XR8004VS X	20	.28	21.0	16.8	11.2	8.4
	25	.32	24.0	18.7	12.5	9.4
	30	.35	26.0	21.0	13.7	10.3
	40	.40	30.0	24.0	15.8	11.9
XR8005VS X	20	.35	26.0	21.0	14.0	10.5
	25	.40	29.0	23.0	15.7	11.7
	30	.43	32.0	26.0	17.2	12.9
	40	.50	37.0	30.0	19.8	14.9
XR8006VS X	20	.42	31.0	25.0	16.9	12.6
	25	.47	35.0	28.0	18.7	14.1
	30	.52	39.0	31.0	21.0	15.5
	40	.60	45.0	36.0	24.0	17.8
XR8008VS X	20	.56	42.0	34.0	22.0	17.0
	25	.63	47.0	37.0	25.0	19.0
	30	.69	52.0	41.0	27.0	21.0
	40	.80	59.0	48.0	32.0	24.0
8010SS X	20	.70	53.0	42.0	28.0	21.0
	25	.78	59.0	47.0	31.0	24.0
	30	.86	64.0	51.0	34.0	26.0
	40	1.00	74.0	59.0	40.0	30.0

10 mph .50

To determine GPA for solutions other than water, determine the weight per gallon or specific gravity and use the

Weight per Gallon	Specific Gravity	Multiply By
7.0 lbs.	.84	1.09
8.0 lbs.	.96	1.02
8.34 lbs. (water)	1.00	1.00
9.0 lbs.	1.08	.96
10.0 lbs.	1.20	.91
11.0 lbs.	1.32	.87
12.0 lbs.	1.44	.83

SPRAYER CHECK LIST

Down time in the field caused by breakdowns is costly and time consuming. Many breakdowns can be eliminated by periodic equipment maintenance. By spending time running over this checklist before seasonal spraying application time and following proper after season care, you can save time and money later on.



SAFETY FIRST

Keep hands, feet, and loose clothing away from rotating parts.

Wear the protective clothing recommended by your chemical and fertilizer manufacturer when working with chemicals.

Be sure rear safety stand is lowered before unhooking sprayer from tractor, if the sprayer is equipped with this stand.

CHECK Before Going To The Field:

1. NOZZLES

Check the tip for excessive wear by checking for grooves in or near the tip opening.

2. HOSES

Check all hoses for worn or soft spots. Be sure all hose clamps are tightened. Be sure no hoses are kinked or pinched. Check for leakage in any of the lines.

3. BOOM HINGES

Clean and grease the hinges to maintain proper breaking action of the boom.

4. REPLACEMENT PARTS

Replace all worn or damaged parts.

NOTE: Demco does not and will not make any recommendations concerning the application of various chemicals or solutions. These recommendations relate to either amount or procedure of materials applied. If you have any questions regarding the application of certain chemicals or solutions, contact your chemical supplier and follow chemical manufacturer recommendations as well as all licensing and use restrictions or regulations.

After Season Care:

NOTE: It is important that when cleaning the sprayer one wears proper safety equipment. See your chemical or fertilizer package for this information.

1. After spraying chemicals, run water mixed with ammonia through the tank, pump, and all hose hookups. If wettable powder dries out in the system, it is very difficult to put back into suspension and can cause malfunction, damage or injury.
2. Disassemble the tips and rinse with water or cleaning solution. (Appropriate for chemical sprayed.)
3. Clean the tip opening with a wooden toothpick. Never use wire or a hard object that could distort the opening.
4. Water rinse and dry the tips before storing.
5. Be sure to dispose of all unused chemicals or solutions in a proper and ecologically sound manner.



P.O. BOX 189
4010 320th St., BOYDEN, IA. 51234
PH: (712) 725-2311
FAX: (712) 725-2380
TOLL FREE: 1-800-54DEMCO (1-800-543-3626)
www.demco-products.com

**Go online to www.demco-products.com for Demco
warranty policies & product registration.**