

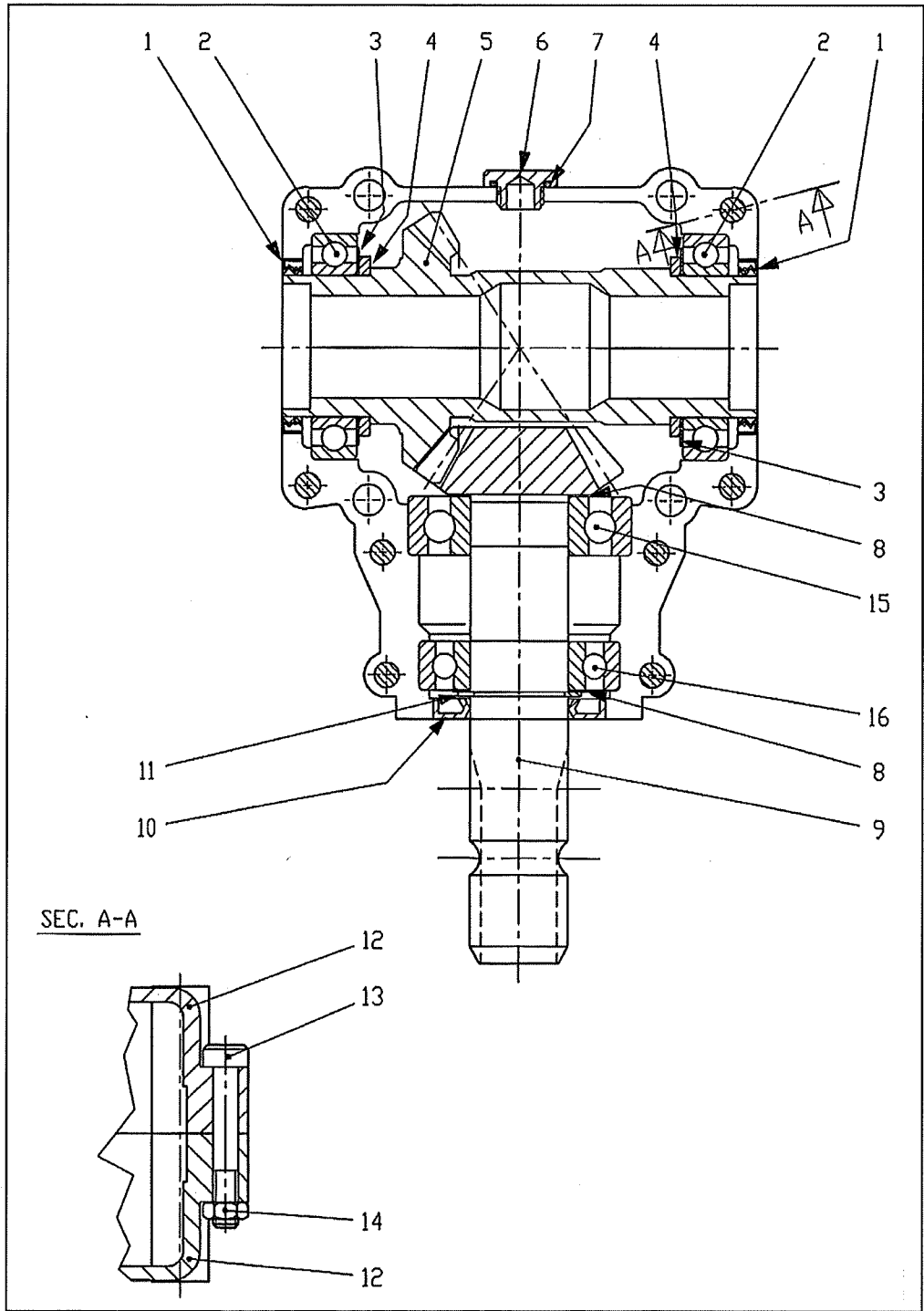

Farm & Garden Equipment  
**Del Morino**

Del Morino srl, v. Caroni di Sotto 19,  
I-52033 Caprese Michelangelo AR Italy  
Ph: +39-575-791059 Fax: +39-575-791210  
<http://www.Italia.com/Delmorino>  
New E-Mail: [delmorin@vinf.ats.it](mailto:delmorin@vinf.ats.it)



Del 105 Flash Tiller Gearbox (3)



Farm & Garden Equipment  
**DelMorino**

Del Morino srl , v.Caroni di Sotto 19,  
 I-52033 Caprese Michelangelo AR Italy  
 Ph: +39-575-791059 Fax: +39-575-791210  
<http://www.Italia.com/Delmorino>  
 New E.Mail: [delmorin@vinf.ats.it](mailto:delmorin@vinf.ats.it)

SPARE PARTS LIST – GEAR BOX COMER 281.037 – 540 R.P.M.				
REF.	DESCRIPTION	CODE #	Q.TY	
1	OIL SEAL 50X62X7	8.7.1.01260	2	
2	BEARING 6010	8.0.1.00473	2	
3	SHIM 50.3x0.5	0.712.7505.00	2	
4	SPACER	0.281.7103.00	2	
5	GEAR 36 Z19 M5	0.259.6039.00	1	
6	PLUG	0.281.7100.00	1	
7	OR-3068	8.7.6.00636	1	
8	SHIM 35.3x0.6	0.259.7506.00	2	
9	PINION Z13 M5	0.259.5001.00	1	
10	OIL SEAL 35X62X7	8.7.3.01259	1	
11	SNAP RING 35 UNI7435	8.5.1.00005	1	
12	CASING	1.281.0303.00	2	
13	SCREW M8X55 8.8	8.1.2.02019	8	
14	HEX. NUT M8	8.2.1.00985	8	
15	BALL BEARING 6307	8.0.1.00049	1	
16	BEARING 6207	8.0.1.00870	1	
17				
18				
19				
20				
21				
22				
23				
24				
25				
26				
27				
28				
251				
252				
253				