



Checchi & Magli

PLASTIC MULCHING MACHINE

PLASTIC - STOP PLUS

**USE AND
MAINTENANCE
MANUAL**

Original instructions in English language

Manual code n.: 998673/1

Edition: 04/2015

Language: english

SUMMARY

1	GENERAL INFORMATION.....	1
2	TECHNICAL INFORMATION	3
3	SAFETY INFORMATION	8
4	SAFETY INFORMATION CONCERNING HANDLING AND INSTALLATION	10
5	ADJUSTMENT INFORMATION.....	13
6	INFORMATION FOR USE	20
7	MAINTENANCE INFORMATION	25
8	INFORMATION CONCERNING REPLACEMENTS.....	28
A	ENCLOSURES.....	29

ANALYTICAL INDEX

A		
	Adjusting the front support wheels	19
	Adjusting the hoeing disks	15
	Adjusting the hoeing shares	13
	Adjusting the mulch sheet idle roller.....	19
	Adjusting the mulch sheet unrolling tension	19
	Adjusting the plastic mulch sheet pressure wheels	17
	Adjusting the ridging disks.....	16
	Adjusting the ridging shares.....	14
	Aim of the manual	1
	Analytical index.....	III
	Annexed documentation	1
	Assistance request procedure	1
C		
	Cleaning the work vehicle.....	25
D		
	Declaration of conformity	6
	Disclaimer notice.....	2
F		
	Forming a seedbed or planting bed.....	22
	Front support wheel assembly.....	12
G		
	General description	3
	General safety instructions	8
	Glossary of terms.....	2
H		
	Handling and lifting the packed unit.....	10
	Hitching and unhitching the work vehicle to and from the tractor	20
I		
	Information and safety signs.....	6
	Irrigation hosepipe	32
	Irrigation hosepipe laying attachment.....	33
K		
	Kit for rear 3-point hitching	29
L		
	Lifting and transporting the work vehicle	11
	Loading the roll of mulch mulch sheet	22
	Lubrication points diagram	27

M	
Main parts	3
Maintenance interval schedule	25
Manufacturer and machine identification details	1
Mulching machine specifications and performance	4
Mulching machine specifications and performance when coupled with planting machine	5
Mulch sheet laying procedure	21
N	
Night-time work or poor visibility conditions	22
Noise	7
O	
Optional accessories	7
Optional accessories	29
P	
Packing	10
Permitted gradients	5
Procedure for using the mulching machine combined with the planting machine	24
Prolonged disuse of the work vehicle	24
R	
Raised bed former and shaping roller	33
Reinforced frame kit	30
Residual risks	7
S	
Safety advice concerning use	20
Safety advice for handling and transportation	10
Safety advice for maintenance	25
Safety advice for the adjustments	13
Safety instructions for adjustments and maintenance	9
Safety instructions for handling and transportation	8
Safety instructions for use and operation	8
Scrapping the work vehicle	28
Summary	III
Support structure assembly	12
T	
Transit on public roads	23
Transporting the work vehicle	22
Troubleshooting	26
Tyre check	25
U	
Unpacking and assembly	11

Aim of the manual

This instruction manual is produced by the manufacturer to provide all those who have dealings with the plastic mulching machine stated on the cover (which may also be referred to hereinafter as the 'work vehicle' or mulching machine) with all the necessary information and criteria to apply for its use.

Apart from adopting good use practices, operators (in compliance with their job responsibilities) are also required to read and understand the information contained in this use manual and put it into practice exactly as stated.

The original instructions are supplied by the manufacturer in English language.

To fulfil legal or commercial requirements, the original instructions may be supplied by the manufacturer in other languages.

This manual is an integral part of the work vehicle; it must be kept for future reference, in an easily accessible place known to all those concerned, for the entire working life of the work vehicle.

If the work vehicle is sold on, the seller is required to pass on the manual to the new owner.

The illustrations may differ from the actual configuration of the work unit however this does not affect in any way

the instructions provided.

For any doubts contact the manufacturer or authorised service centres.

To highlight certain parts of the manual's contents deemed important for safety or information reasons the following symbols have been used, whose meanings are outlined below.



Danger - Warning

This indicates seriously hazardous situations which, if ignored, could put the health and safety of those involved at risk.



Caution

This shows that appropriate behaviour must be adopted in order to prevent the health and safety of those involved being at risk.



Information

This highlights vital technical information which must not be overlooked.

Manufacturer and machine identification details

The plate shown, which is applied directly to the work vehicle, contains all the essential information for identifying the machine and the manufacturer.

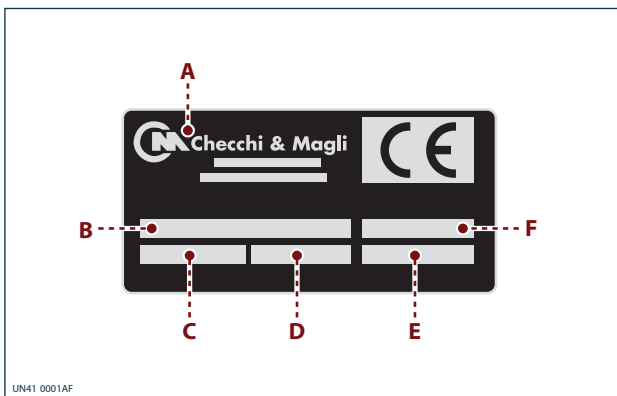

A - Manufacturer's identification details

B - Work vehicle type

C - Work vehicle model

D - Work vehicle gross weight

E - Serial number

F - Year of manufacture

Annexed documentation

Along with this handbook, the customer is given the documentation specified.

- The instructions for use and maintenance of any optional units that may be provided with the work vehicle which are not considered in this manual.
- "EC" Declaration of Conformity for the work unit.

Assistance request procedure

All requests for technical assistance must be made to the manufacturer's Technical Assistance Service or the authorised service centres.

Whenever making requests for technical assistance concerning the work vehicle, remember to quote the data shown on the data plate and the fault encountered.

Disclaimer notice

The work vehicle is delivered to the user under the conditions applicable at the time of purchase and specified in the sale agreement.

- Any modification which is not authorised by the manufacturer
- work unit misuse
- use of the work vehicle by the untrained or unauthorised personnel

- lack of maintenance
- the partial or total failure to comply with the instructions in this manual
- use of non-original spare parts or parts not designed specifically for the model concerned shall result in forfeiture of the warranty and shall relieve the manufacturer of all and any liability for damage caused to persons, animals and property.

Glossary of terms

Rearing/overturning: when the tractor/work vehicle suddenly upsets.

Mulch sheet: a strip of polyethylene or biodegradable material commonly used in mulching (i.e. to cover the ground in which the seedling will be planted).

Row spacing: the distance between each row.

Plant spacing: this is the distance between one seedling and the next in the same row.

Kit for rear 3-point hitch: this is used on the mulching machine when combined with a planting machine, instead of the standard three-point hitch (see "How to use the mulching machine combined with the planting machine").

Reinforced frame kit: this is used on the mulching machine when combined with a planting machine, instead of the standard frame (see "How to use the mulching machine combined with the planting machine").

General description

This machine is designed and built to unroll a sheet of plastic film, used for mulching, and spread it over the ground.

The roll, which is positioned transversely to the direction of travel, is unrolled by the movement of tractor/work vehicle assembly.

Once laid on the ground and properly tensioned, the plastic mulch sheet is covered with soil along the edges, by ploughshares or ridging disks.

The work vehicle is a semi-carried device, equipped with

a frame for attachment to the three-point hitch on a tractor and it is suitable for planting in fields and greenhouses.

The manufacturer has envisaged the installation of additional units and accessories on the work vehicle which modify and optimise its features to meet various work needs.

The work vehicle, which is equipped with specific hitches, can be attached to planting machines in order to spread plastic mulch sheets and plant seedlings at the same time.

Main parts

The illustration shows the main parts of the work vehicle.

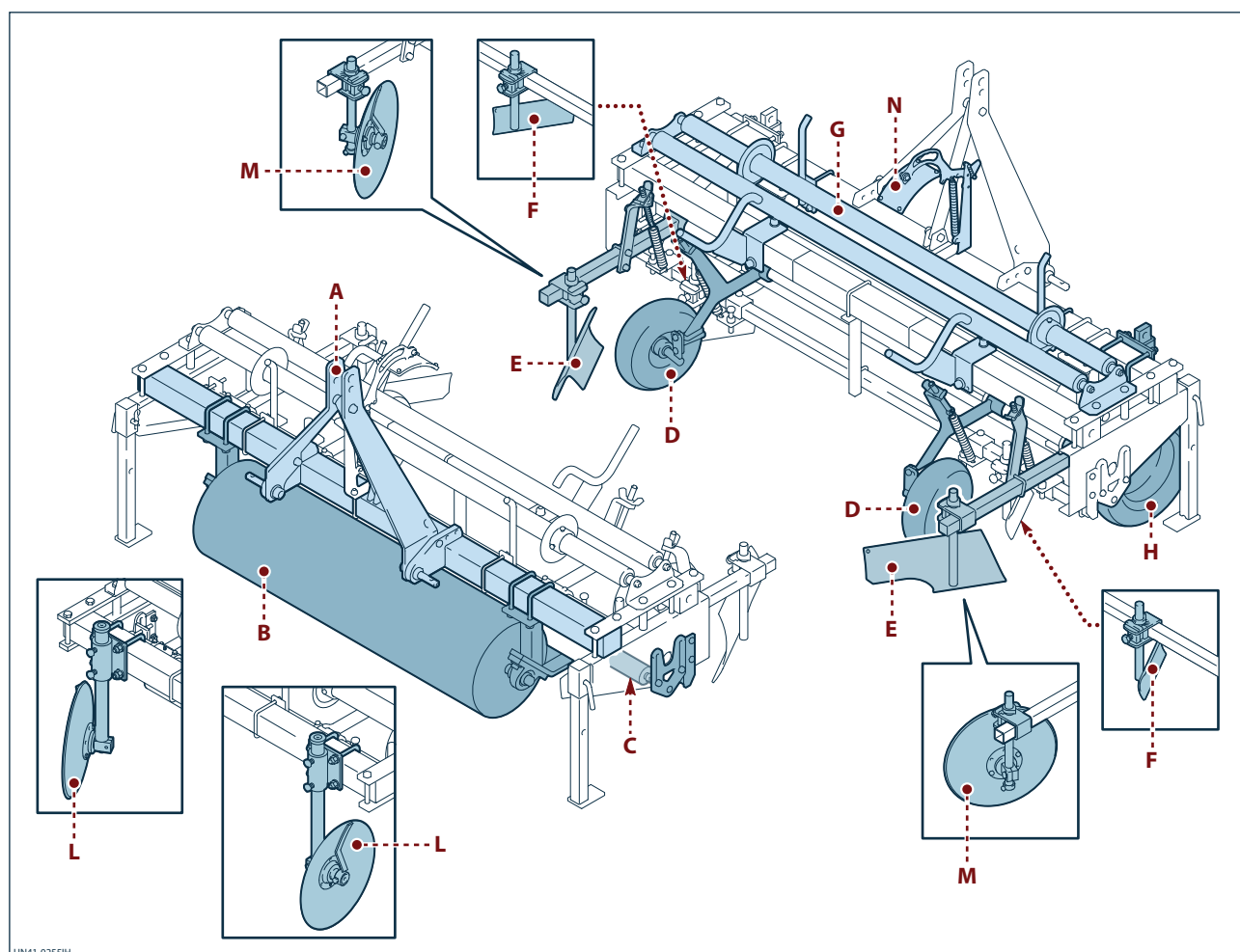

- | | |
|---|-------------------------------|
| A) Structure for attaching to the three-point hitch on a tractor (frame) | F) Hoeing share |
| B) Compacting roller | G) Roll holder |
| C) Mulch sheet idle roller | H) Front support wheel |
| D) Mulch sheet pressure wheel | L) Hoeing disks |
| E) Ridging share | M) Ridging disks |
| | N) Roll brake |

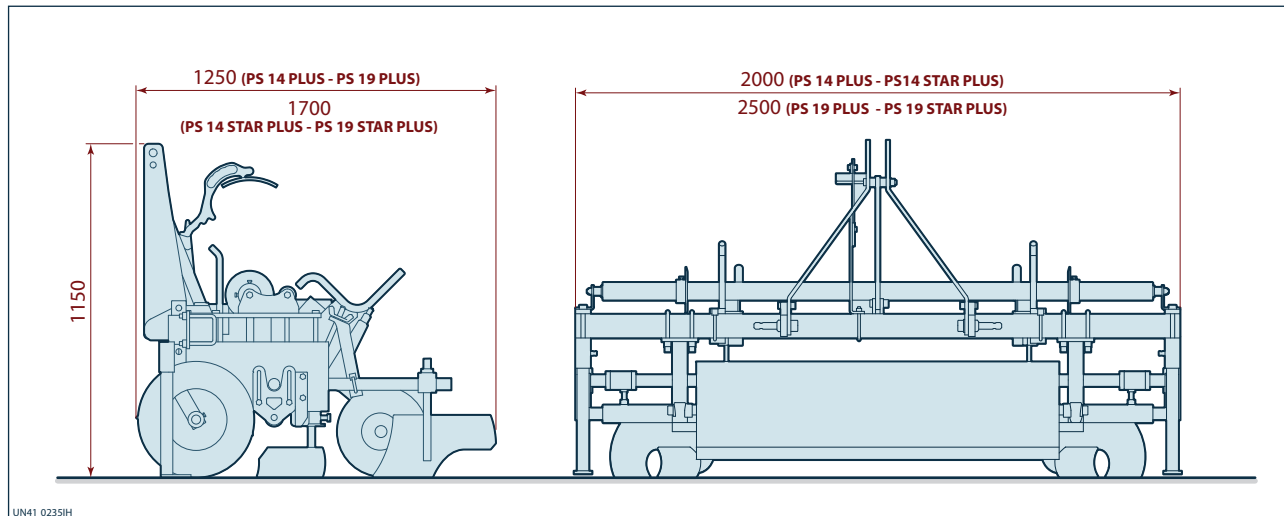
Mulching machine specifications and performance
Overall dimensions.

UN41 0235IH

Technical characteristics		PS 14 PLUS	PS 19 PLUS	PS 14 STAR PLUS	PS 19 STAR PLUS
Required tractor power	HP	25	30	40	45
Maximum working width	cm	140	190	140	190
Front tyre pressure	bar	2,5	2,5	2,5	2,5
Pressure of mulch sheet pressure wheels	bar	0,5÷1 (*)	0,5÷1 (*)	0,5÷1 (*)	0,5÷1 (*)
Work vehicle gross weight (without rolls)	kg	265	315	398	450
Maximum roll diameter	cm	280	280	280	280
Maximum roll width	cm	140	190	140	190

(*) Tyre pressure level at machine delivery: 0.7 bar.
 Recommended tyre pressure for low-resistance mulch sheet 0.5 bar.
 Recommended tyre pressure for resistant mulch sheet: 1 bar.

Planting machines that can be coupled to the machine	Wolf			
	1 unit	2 units	3 units	4 units
PS 14 PLUS	•	•	•	
PS 19 PLUS	•	•	•	•
PS 14 STAR PLUS	-	-	-	-
PS 19 STAR PLUS	-	-	-	-

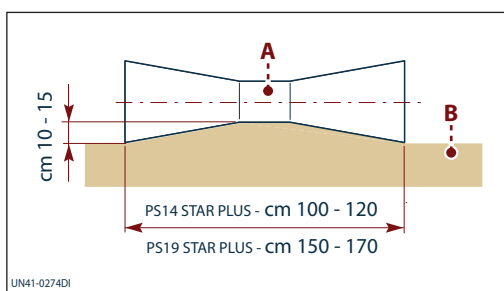
Dimensions of seedbed or planting bed with raised bed formers

UN41-0274DI

- (A) Shaping roller
 (B) Ground

Work vehicle versions					
Version	Stainless steel roller	Hoeing and/or ridging shares	Hoeing and/or ridging disks	Rubber wheels	Raised bed formers
PS 14 PLUS (stainless steel)	•	•			
PS 14 PLUS (stainless steel)	•		•		
PS 14 PLUS (rubber wheels)		•		•	
PS 14 PLUS (rubber wheels)			•	•	
PS 19 PLUS (stainless steel)	•	•			
PS 19 PLUS (stainless steel)	•		•		
PS 19 PLUS (rubber wheels)		•		•	
PS 19 PLUS (rubber wheels)			•	•	
PS 14 STAR PLUS	•	•	•	•	•
PS 19 STAR PLUS	•	•	•	•	•

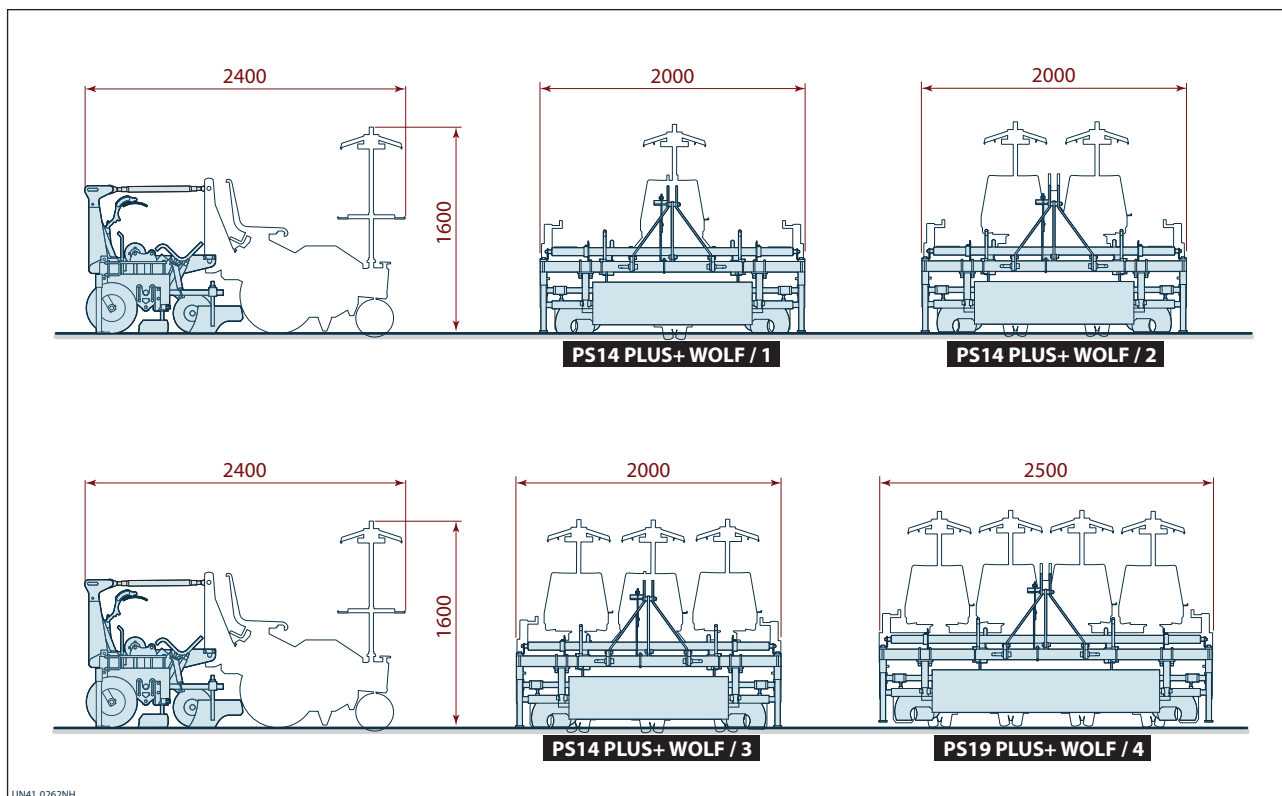
Mulching machine specifications and performance when coupled with planting machine
Overall dimensions.

UN41 0262NH

Technical characteristics

		PS 14 PLUS + WOLF/1	PS 14 PLUS + WOLF/2	PS 14 PLUS + WOLF/3	PS 19 PLUS + WOLF/4
Required tractor power	HP	35	45	55	65
Row spacing	cm		min. 30 - max. 90	min. 30 - max. 45	
Plant spacing	cm	min. 20 - max. 198			
Planting unit	N°	1	2	3	4
Tyre pressure levels	bar	2,5			
Weight	kg	450	550	800	850

Permitted gradients

The ground conditions (slippery, sloping, etc.) and the type of tractor used can reduced the stability of the tractor/work vehicle assembly and cause sudden, dangerous movements, especially when the work vehicle is lifted off the ground.

It is up to the tractor driver to assess the environmental conditions of the work area and not to exceed the permitted gradients established for the tractor with the equipment mounted on it (see tractor user manual).

Declaration of conformity
CHECCHI & MAGLI s.r.l.

Via Guizzardi n° 38
40054 - BUDRIO (BOLOGNA) - ITALIA

We hereby declare, under our own responsibility, that the "PLASTIC MULCHING MACHINE" models **PS 14** and **PS 19** comply with the Essential and Health Safety Requirements provided for by Directive 2006/42/EC.

The following regulations in particular have been applied: UNI EN ISO 12100-1, UNI EN ISO 12100-2 and UNI EN 13857, on machine safety.

Budrio

CHECCHI & MAGLI s.r.l.
Legal representative
Nerio Checchi

Information and safety signs

Danger - Warning

Check that all the plates are legible; if they are not, clean them or - if they are damaged - replace them, applying the new ones in the same place as the old ones.

The illustration shows the locations and meanings of the safety signs.

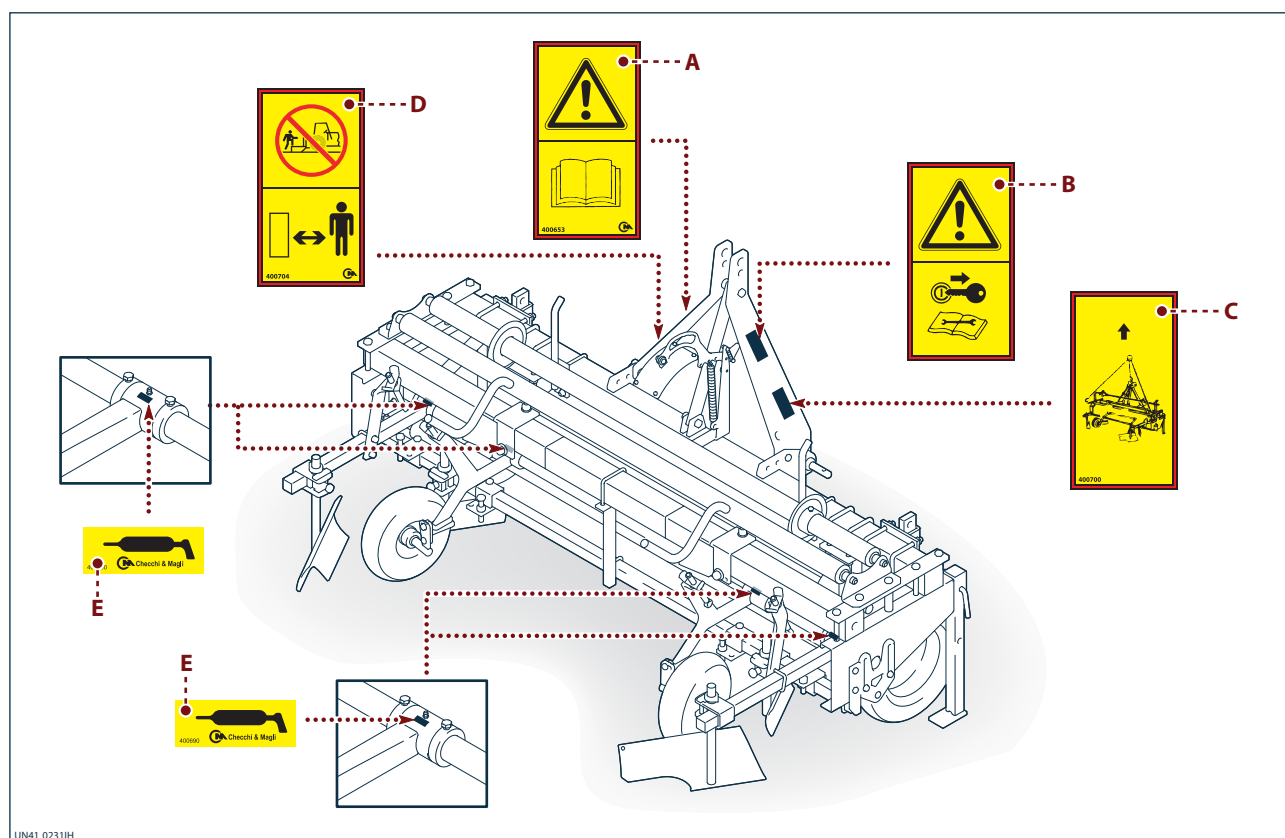

- A) Hazard plate:** read the use and maintenance manual before using the work vehicle.
- B) Hazard plate:** switch off the tractor; remove the ignition key and store in a safe place before carrying out any type of work on the work vehicle.

- C) Information plate:** strap up at the anchor points shown to lift the work vehicle.
- D) Prohibition plate:** forbidden to climb on the machine; keep a safe distance.
- E) Information plate:** this shows the greasing points.

Optional accessories

The following chart shows the optional accessories available for installation.

Manual lift row tracers
Hosepipe laying device
Hosepipe laying kit (AL-S-PS)
Roller for drainage holes in mulch sheet (machine model PS 14)
Roller for drainage holes in mulch sheet (machine model PS 19)
Rear 3-point hitch kit for coupling mulching machine to planting machine (see "Planting machines that can be coupled to the mulching machine")
PS reinforced frame kit for coupling mulching machine to planting machine (see "Planting machines for coupling to the mulching machine")
Dual output microgranular fertiliser spreader (with linear dispensing function and mechanical transmission)
Dual output manure spreader (with linear dispensing function and mechanical transmission)
PS14 STAR raised bed forming kit (for PS 14 only, to couple to existing machines)
PS19 STAR raised bed shaping kit (for PS 19 only, to couple to existing machines)
Pair of front support wheels for "PS" mulching machine



Information

For accessory installation and features, see the related information in the "Attachments" section or in the instructions supplied with the accessory.

Noise

The use of the plastic mulching machine - even when coupled to a planting machine - does not mean a significant increase in the noise levels of the tractor to which the mulching machine or the mulching machine/planting machine assembly is hitched.

Check the tractor manufacturer's manual to decide which PPE to adopt for hearing protection.

Residual risks

During the design and construction stages, the manufacturer has focused particular attention on safety aspects; nevertheless the risks described below remain.

- Danger of getting crushed or trapped when hitching and unhitching the work unit to and from the tractor.

General safety instructions

Failure to comply with some simple safety and prudence rules is the cause of most accidents and injuries at work.

In most cases, accidents can be avoided by foreseeing the possible causes and consequently acting with the necessary care and caution.

Exercising caution and care is the best way of avoiding accidents.

Read this manual carefully before proceeding with any operations concerning use, maintenance or other work on the work vehicle.

Heed and comply with the symbols on the work vehicle, especially those concerning safety.

When the machine is in use, the operator and the people directly involved in the operations must wear accident prevention equipment; for this purpose contact the safety manager.

Never leave the driver's seat when the tractor engine is running.

Safety instructions for handling and transportation

Perform lifting and handling manoeuvres as instructed in the plates on the work vehicle and in the user manual supplied by the manufacturer.

Loading, unloading, handling and lifting operations must be carried out by qualified and authorised personnel that has received specific training.

Before transporting, make sure the work vehicle and its components are anchored to the means of transport, to prevent uncontrolled movements.

Check that the work vehicle complies with the maximum clearance limits; where necessary, provide the signs required by applicable law.

Safety instructions for use and operation

To reduce risks of accidents as much as possible, the tractor must be driven by a trained operators who is able to coordinate the work of all the other staff involved in the work.

The machine must only be put to the uses specified by the manufacturer; misuse may cause safety and health risks and could result in damage of a financial nature.

Before using the work vehicle check that the guards are all fitted correctly.

Before hitching the work vehicle up to the tractor, make sure the tractor is in good condition.

Check that the work vehicle coupling to the tractor at the third point of the hitch is securely locked so that it cannot work loose.

When driving on the roads, the driver must comply with the highway code, ensuring the tractor is road-worthy and the relative signs to signal jutting objects are affixed.

Do not carry people on the work vehicle when moving from one area to another or on the roads.

Never leave the driver's seat when the tractor engine is running.

Before leaving the tractor, lower the work vehicle to the ground, stop the engine, engage the parking brake, and remove the ignition key from the control panel and store in a safe place.

Safety instructions for adjustments and maintenance

Maintenance is of primary importance for the efficiency and reliability of the machine and is one of the most important safety elements.

Maintenance schedule operations must be carried out at the set intervals and in the manner foreseen by the manufacturer.

Maintenance and adjustment work must be carried out with the work vehicle on flat, compact ground,

with the tractor engine off, parking brake engaged, ignition key removed.

In the event of a failure, do not carry out any repairs on site unless you are certain that the area you are in is appropriate and the equipment required is available; it is more advisable to take the time needed to return the business premises rather than carry out repair work in poor safety conditions.

Safety advice for handling and transportation

Perform handling and transportation manoeuvres in compliance with the information provided by the manufacturer and stated directly on the machine, on the packing and in the instructions for use.

The staff assigned to handling the load must have the required ability and experience and must be skilled in the use of the lifting means adopted.

Packing

The type of packing is chosen according to the selected means of transport and the destination. To contain packing as much as possible, the work vehicle machine is delivered dismantled.

The illustration shows the type of packing most commonly used. All the information for safe loading/unloading procedures is printed on the packing.

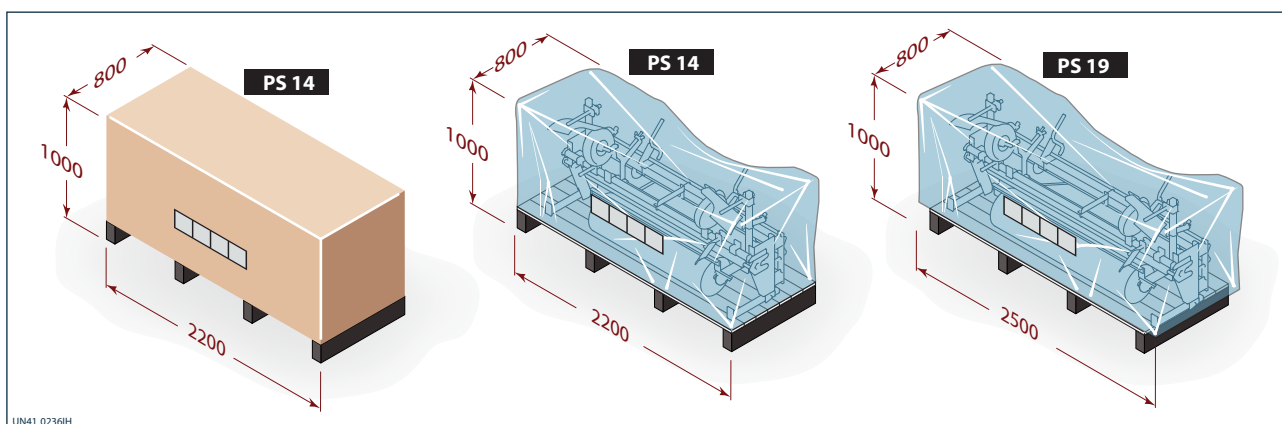

Handling and lifting the packed unit

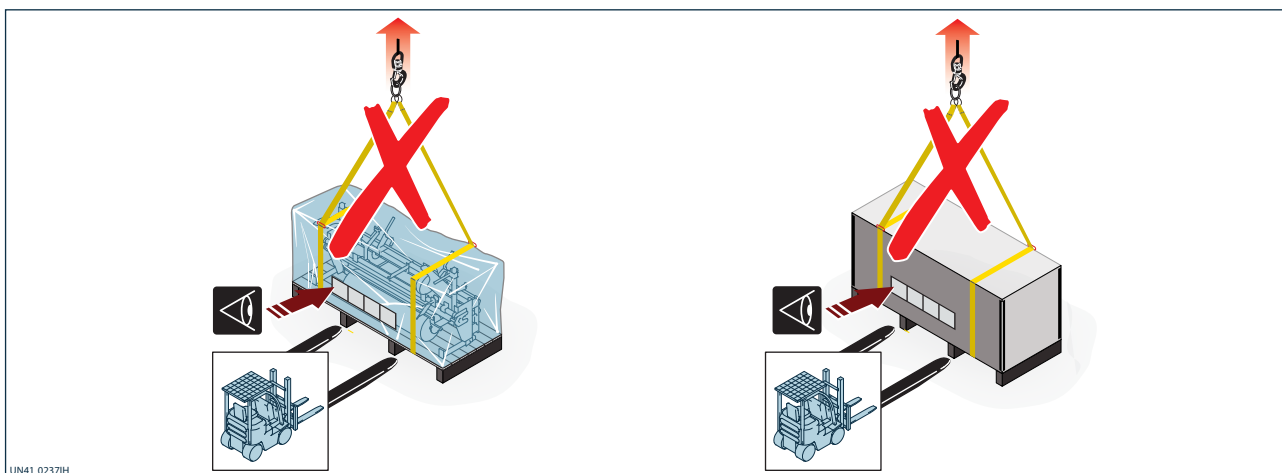

Danger - Warning

Lift the packed machine using appropriate hoisting means for the load to lift.

Check the parcel weight stated on the packing itself.

Authorised personnel must comply with the instructions contained on the packing, in particular those concerning security.

Handle the packed equipment slowly, with care and caution, to prevent it swinging dangerously.

Unpacking and assembly

The assembly of the work vehicle must be carried out at an authorised service centre or at company facilities equipped with appropriate equipment and suitably trained personnel, in order to guarantee safety during unpacking and installation.

During unpacking, check that the components are in

good condition and tally with the number stated; in the event of damage, report the damage to the retailer or directly to the manufacturer within 8 days of receiving the machine.

The packing materials must be appropriately disposed of or recycled in accordance with the laws in force.

Lifting and transporting the work vehicle



Danger - Warning

Lift the work vehicle using appropriate hoisting means for the load to lift.

Check the weight of the mulching machine, or the mulching machine coupled to the planting machine, in the "Technical information" section.



Danger - Warning

During lifting and handling operations anyone not involved must keep a safe distance.

The illustration shows the mulching machine harnessing points and lifting procedure.

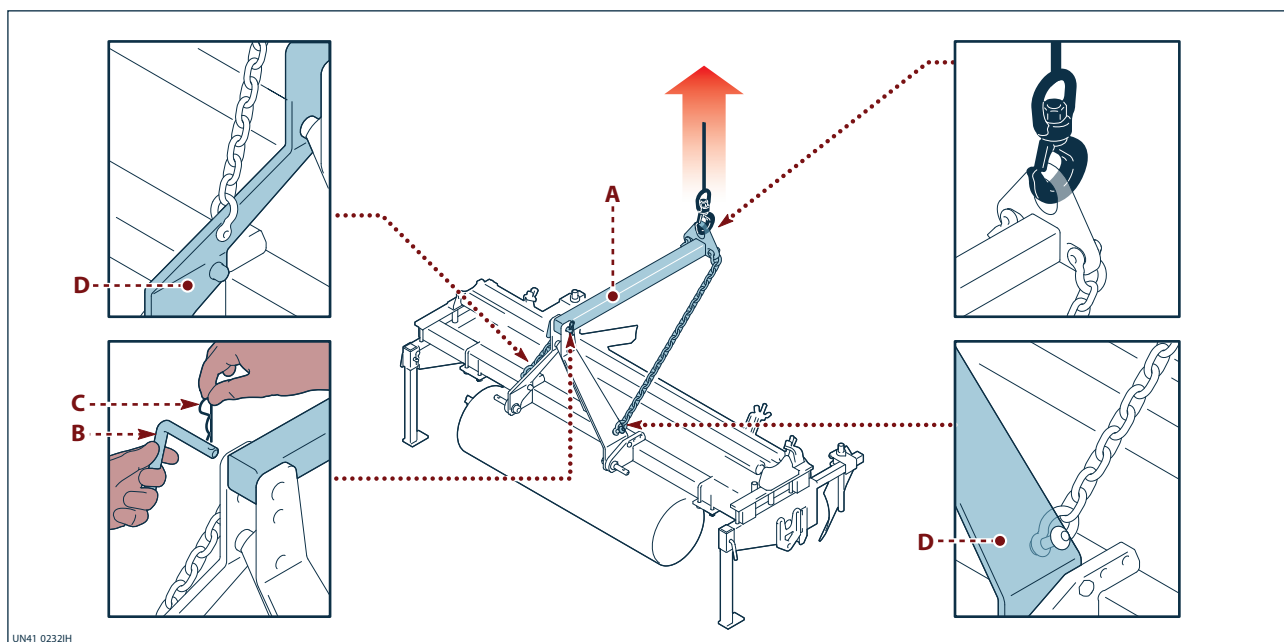

To lift the work vehicle, proceed as follows.

- 1) The specific tool (A) provided with the work vehicle for lifting.
- 2) Strap up the work vehicle as shown in the figure.
- 3) Check that the pin (B) is secured by the lock pin (C) and that the chains are fastened stably to the frame (D).
- 4) Lift the work vehicle and place it on the means of transport.
- 5) Anchor the work unit to the means of transport with ropes and secure the wheels with wedges.
- 6) Affix the relative signalling signs to any parts jutting out from the means of transport.

The illustration shows the harnessing points and the procedures for lifting the mulching machine when coupled to the planting machine.

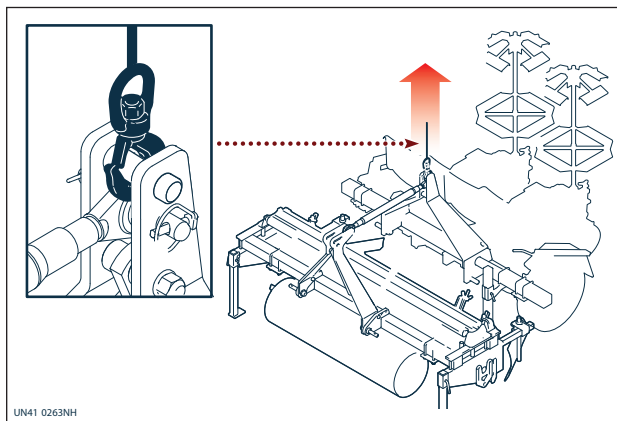

UN41 0263NH

Support structure assembly

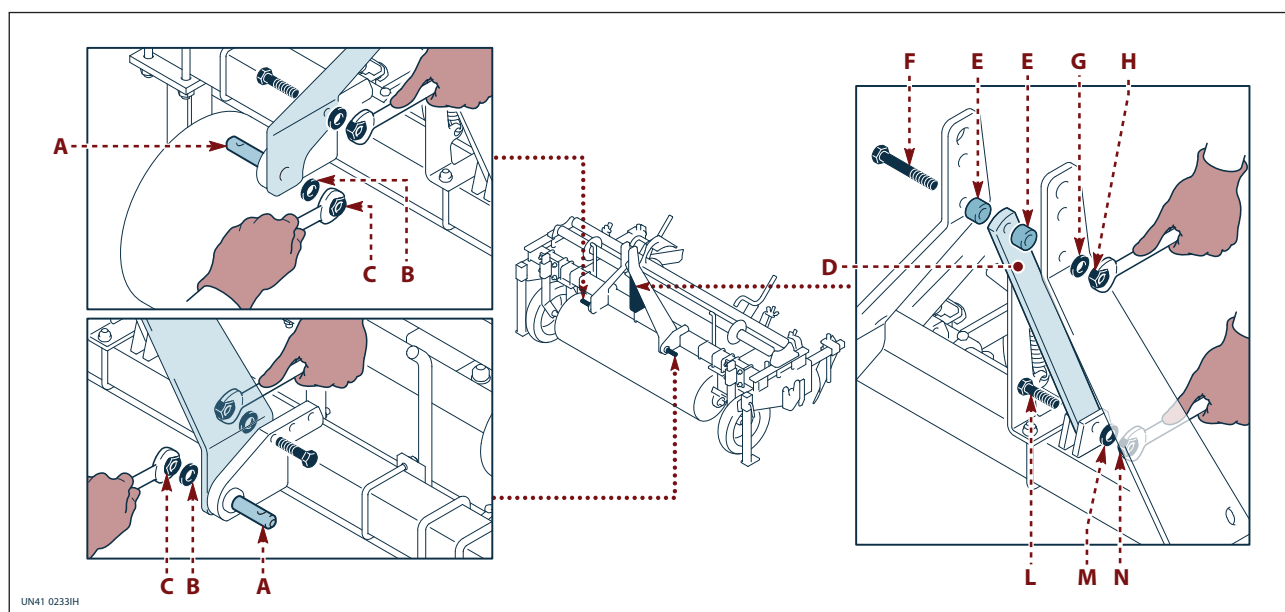

UN41 0233IH

To assemble the support structure, proceed as outlined below.

- 1) Lower the structure onto the work vehicle.
- 2) Insert the pins (A).
- 3) Insert the washers (B).
- 4) Tighten the nuts (C).

- 5) Position the tie rod (D) as shown in the figure.
- 6) Insert the bushings (E).
- 7) Insert the screw (F) and the washer (G).
- 8) Tighten the nut (H).
- 9) Insert the screw (L).
- 10) Insert the washer (M).
- 11) Tighten the nut (N).

Front support wheel assembly

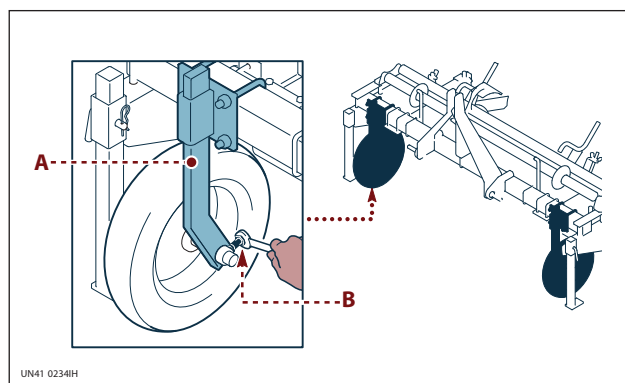

UN41 0234IH

To assemble the front support wheel, proceed as outlined below.

- 1) Insert the wheel hub into the support (A).
 - 2) Tighten the screw (B).
- Repeat the same procedure for the other wheel.

Safety advice for the adjustments

Adjustment work must be carried out with the work vehicle on flat, compact ground, with the tractor en-

gine off, parking brake engaged, and ignition key removed, and adopting all the necessary safety measures required to work safely.

Adjusting the hoeing shares

The hoeing shares are used to make furrows in the soil where the edges of the mulch sheet will be laid and which are adjustable in terms of width, depth, and inclination.

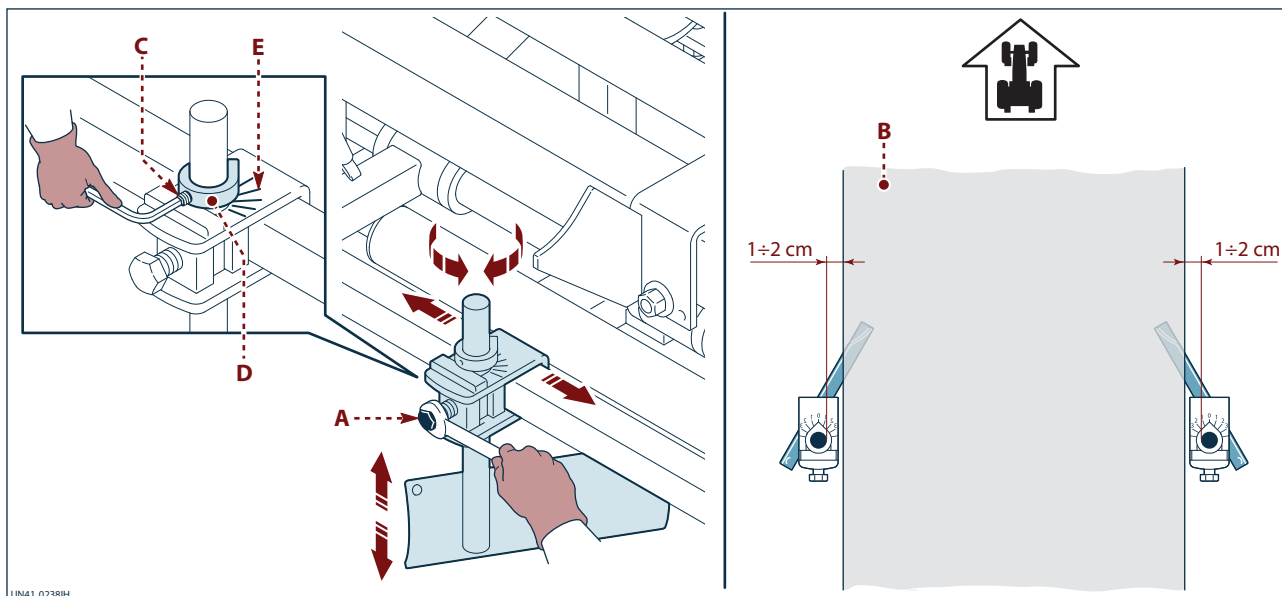

To adjust the hoeing shares, proceed as outlined below.

- 1) Loosen the screw (A).
- 2) Place the shares at the distance from the edge of the mulch sheet (B) shown in the figure.
Adjust the shares as required, in the way described.
 - Raise or lower the shares to increase or decrease the depth of the furrow.
 - Alter the angle of the shares to increase or decrease the width of the furrow.

- 3) Tighten the screw (A).

If the pointer (D) prevents the share lowering as desired, proceed as described.

- 1) Loosen the screw (C) and lift the pointer (D) without turning it.
The pointer must not be turned as it would desynchronise the initial inclination of the share in relation to the gauge scale (E).
- 2) Tighten the screw (C).

Repeat the same procedure for the other share.

Adjusting the ridging shares

The ridging shares are used to cover the edges of the plastic mulch sheet with soil.

- *Adjusting the distance of the ploughshares from the edge of the plastic mulch sheet*

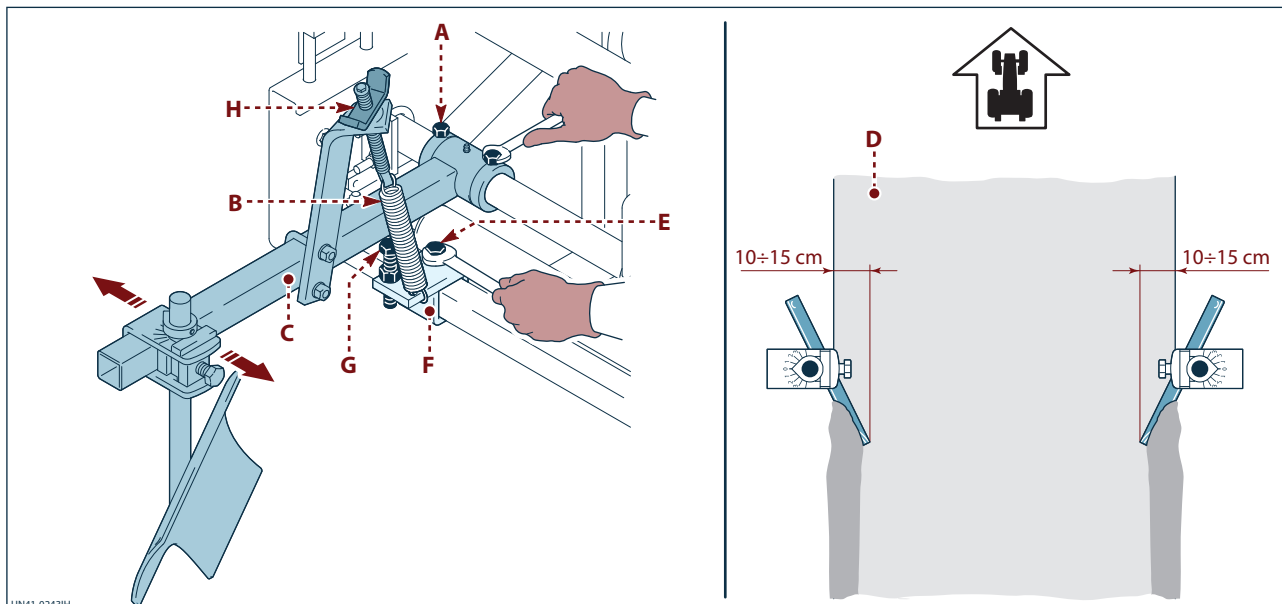

For adjustments, proceed as outlined below.

- 1) Use the handwheel (**H**) to slacken off the spring.
 - 2) Release the spring (**B**) from the support (**F**).
 - 3) Loosen the screws (**A**).
 - 4) Move the arm (**C**) so that the share is as far away from the edge of the mulch sheet (**D**) as stated in the figure.
 - 5) Tighten the screws (**A**).
 - 6) Loosen the screw (**E**).
 - 7) Move the support (**F**) and place it in position with the arm (**C**).
Check that the stroke limit (**G**) tallies with the arm.
 - 8) Tighten the screw (**E**).
 - 9) Attach the spring to the support (**F**).
 - 10) Use the handwheel (**H**) to tension the spring.
- Repeat the same procedure for the other share.

- *Adjusting the share pressure on the ground*

To adjust the ploughshare pressure, proceed as outlined below.

- 1) Turn the handwheel (**H**) to increase or decrease the share pressure on the ground.

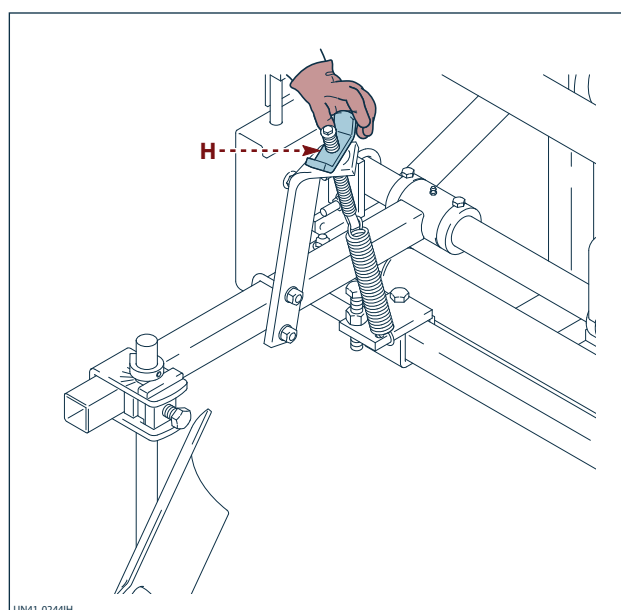

- *Adjusting the depth, tilt, and longitudinal movement of the share*

For adjustments, proceed as outlined below.

- 1) Loosen the screw **(A)**.
 - Raise or lower the share to increase or decrease the amount of soil to ridge over the mulch sheet.
 - Alter the angle of the share to increase or decrease the width of the ridging over the sheet.
 - Move the share closer to or away from the pressure wheel to bring forward or delay the start of the ridging.
- 2) Tighten the screw **(A)**.

If the pointer **(C)** prevents the share lowering as desired, proceed as described.

- 1) Loosen the screw **(B)** and lift the pointer **(C)** without turning it. The pointer must not be turned as it would desynchronise the initial inclination of the share in relation to the gauge scale **(D)**.
- 2) Tighten the screw **(A)**.

Repeat the same procedure for the other share.

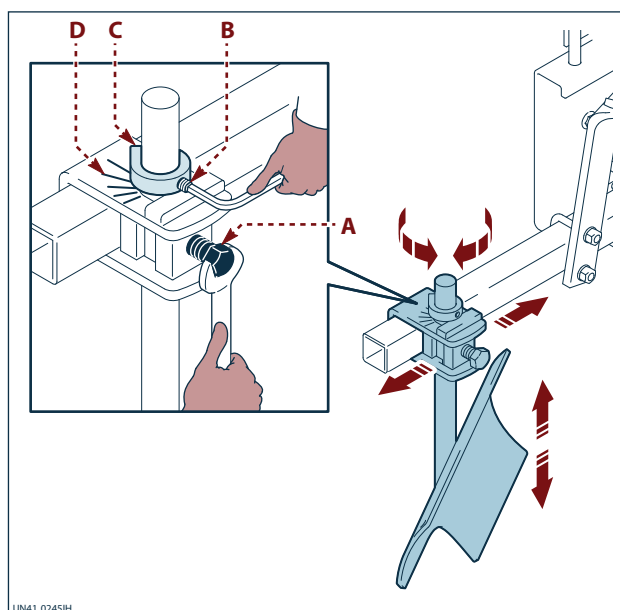

Adjusting the hoeing disks

The hoeing disks are used to make furrows in the soil where the edges of the mulch sheet will be laid and are adjustable in terms of width, depth, and inclination.

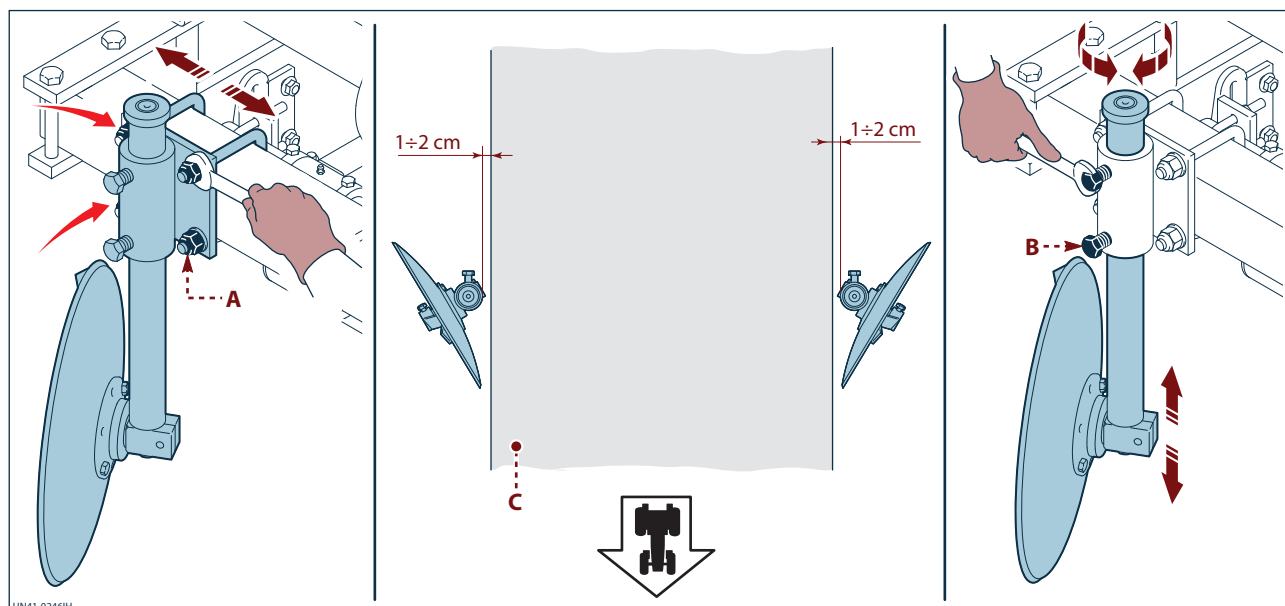

To adjust the hoeing disks, proceed as outlined below.

- 1) Loosen the nuts **(A)**.
- 2) Place the disks at the distance from the edge of the mulch sheet **(C)** shown in the figure.
- 3) Tighten the nuts **(A)**.

Adjust the disks as required, in the way described.

- 4) Loosen the screws **(B)**.
 - Raise or lower the disks to increase or decrease the depth of the furrow.
 - Alter the angle of the disks to increase or decrease the width of the furrow.
 - 5) Tighten the screws **(B)**.
- Repeat the same procedure for the other disk.

Adjusting the ridging disks

The ridging disks are used to cover the edges of the plastic mulch sheet with soil.

- *Adjusting the distance of the disks from the edge of the plastic mulch sheet.*

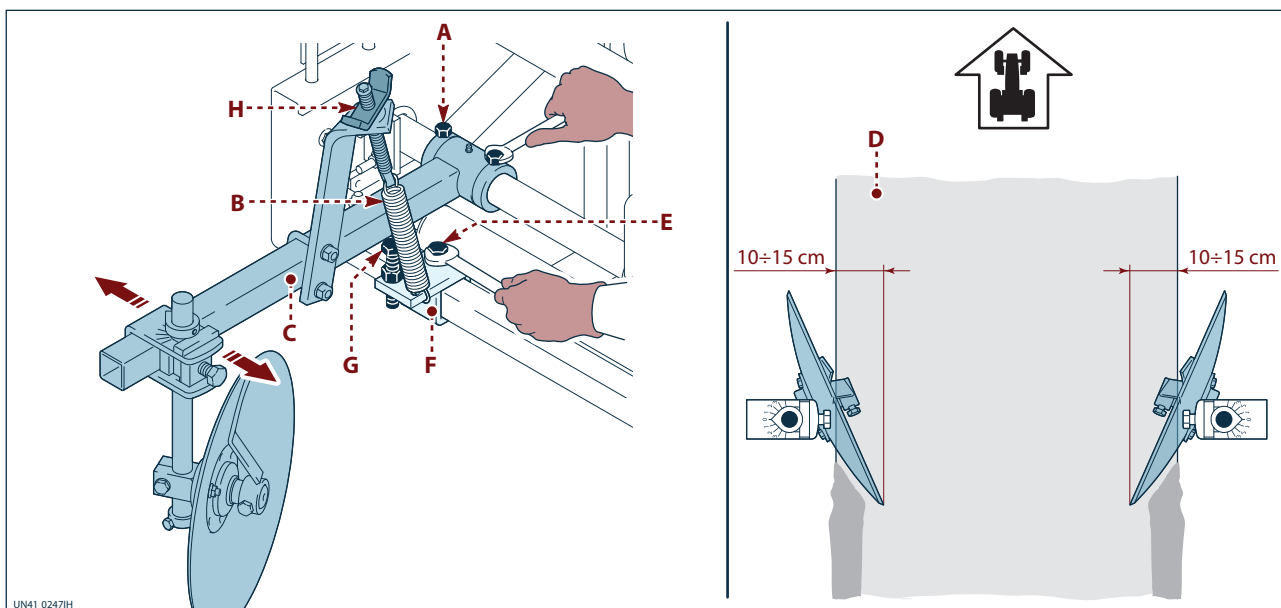

To adjust the disk, proceed as outlined below.

- 1) Use the handwheel (**H**) to slacken off spring tension.
- 2) Release the spring (**B**) from the support (**F**).
- 3) Loosen the screws (**A**).
- 4) Move the arm (**C**) so that the disk is as far away from the edge of the mulch sheet (**D**) as stated in the figure.
- 5) Tighten the screws (**A**).
- 6) Loosen the screw (**E**).
- 7) Move the support (**F**) and place it in position with the arm (**C**).
Check that the stroke limit (**G**) tallies with the arm.
- 8) Tighten the screw (**E**).
- 9) Attach the spring to the support (**F**).
- 10) Use the handwheel (**H**) to tension the spring.

Repeat the same procedure for the other disk.

- *Adjusting the disk pressure on the ground*

To adjust the disk pressure, proceed as outlined below.

- 1) Turn the handwheel (**H**) to increase or decrease the disk pressure on the ground.

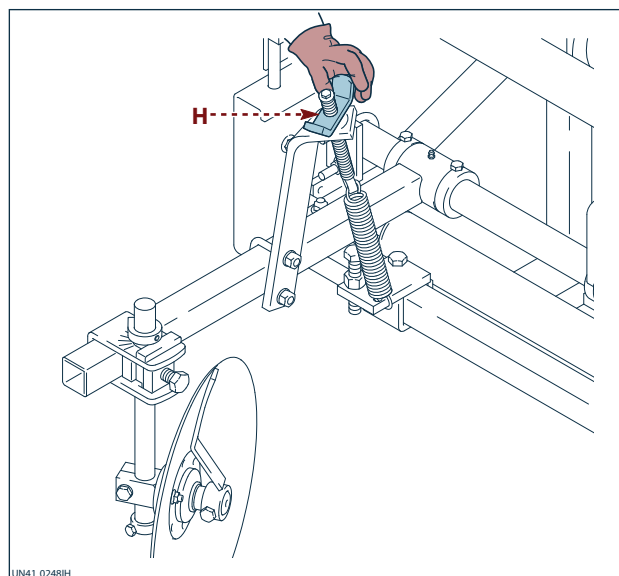

- *Adjusting the depth, tilt, and longitudinal displacement of the disk*

To adjust the disk, proceed as outlined below.

- 1) Loosen the screw **(A)**.
 - Raise or lower the disk to increase or decrease the amount of soil to ridge over the mulch sheet.
 - Alter the angle of the disk to increase or decrease the width of the ridging over the sheet.
 - Move the disk closer to or away from the pressure wheel to bring forward or delay the start of the ridging.
- 2) Tighten the screw **(A)**.

If the pointer **(C)** prevents the disk lowering as desired, proceed as described.

- 1) Loosen the screw **(B)** and lift the pointer **(C)** without turning it. The pointer must not be turned as it would desynchronise the initial inclination of the disk in relation to the gauge scale **(D)**.
- 2) Tighten the screw **(A)**.

Repeat the same procedure for the other disk.

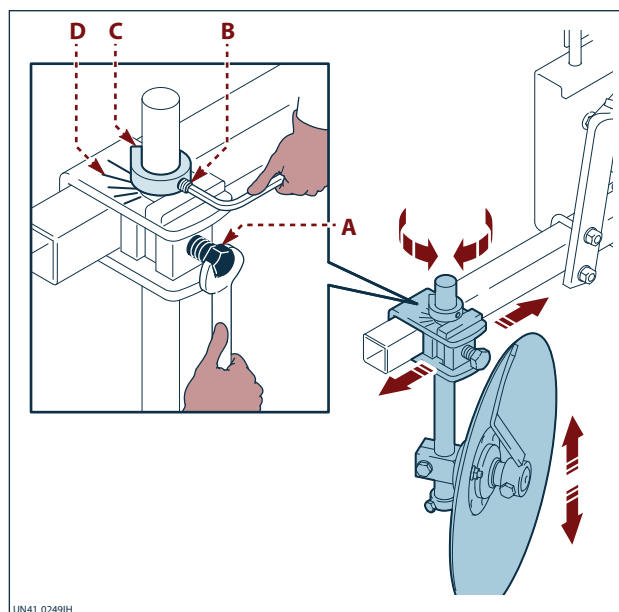

UN41 0249IH

Adjusting the plastic mulch sheet pressure wheels

The pressure wheels are used to keep the mulch sheet tensioned on the ground.

- *Adjusting the distance of the pressure wheels from the edge of the plastic mulch sheet.*

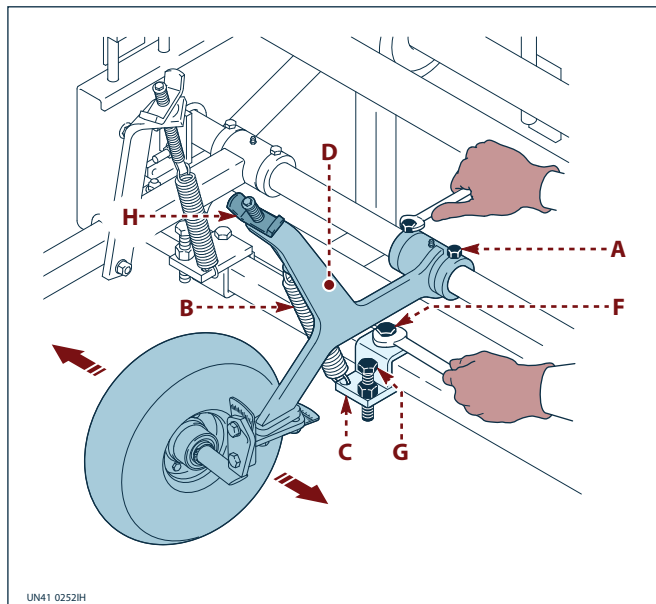

UN41 0252IH

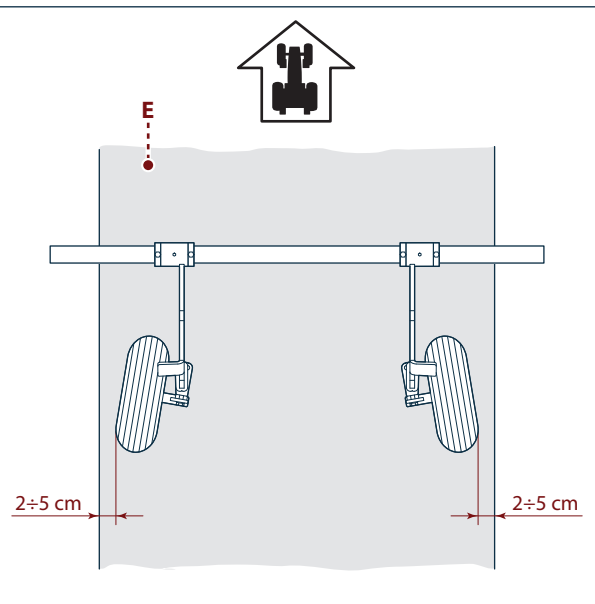

To adjust the pressure wheels, proceed as outlined below.

- 1) Use the handwheel **(H)** to reduce spring tension.
- 2) Release the spring **(B)** from the support **(C)**.
- 3) Loosen the screws **(A)**.
- 4) Move the arm **(D)** so that the wheel is as far away from the edge of the mulch sheet **(E)** as stated in the figure.
- 5) Tighten the screws **(A)**.

- 6) Loosen the screw **(F)**.
 - 7) Move the support **(C)** and place it in position with the arm **(D)**.
 - 8) Check that the stroke limit **(G)** tallies with the arm.
 - 9) Tighten the screw **(F)**.
 - 10) Attach the spring to the support **(C)**.
 - 11) Use the handwheel **(H)** to tension the spring.
- Repeat the same procedure for the other wheel.

- Adjusting the convergence

Alter the convergence of the pressure wheels to increase or decrease the transverse tension of the plastic mulch sheet.

To adjust the convergence, proceed as outlined below.

- 1) Loosen the screws **(A)**.
- 2) Alter the angle of the wheel in relation to the longitudinal axis of the work vehicle as required.
- 3) Tighten the screws **(A)**.

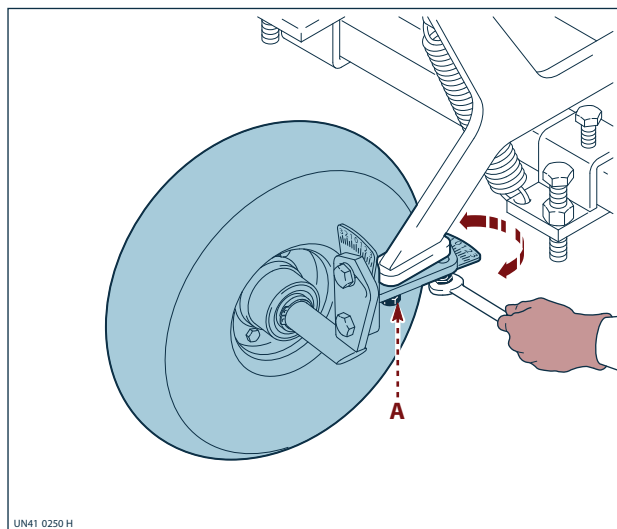

- Adjusting the camber

Alter the camber to move the tyre away from the edge of the plastic mulch sheet in small movements.

To adjust the camber, proceed as outlined below.

- 1) Loosen the screws **(A)**.
- 2) Alter the wheel angle as required.
- 3) Tighten the screws **(A)**.

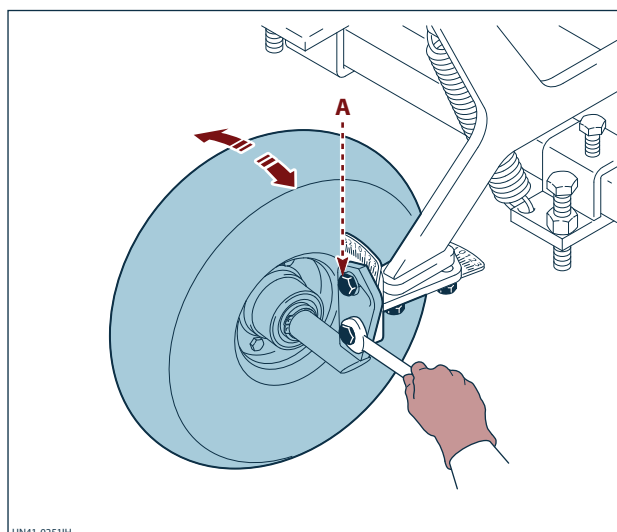

- Adjusting the pressure of the wheels on the plastic mulch sheet

To adjust the wheel pressure, proceed as outlined below.

- 1) Turn the handwheel **(A)** to increase or decrease the wheel pressure on the plastic mulch sheet.

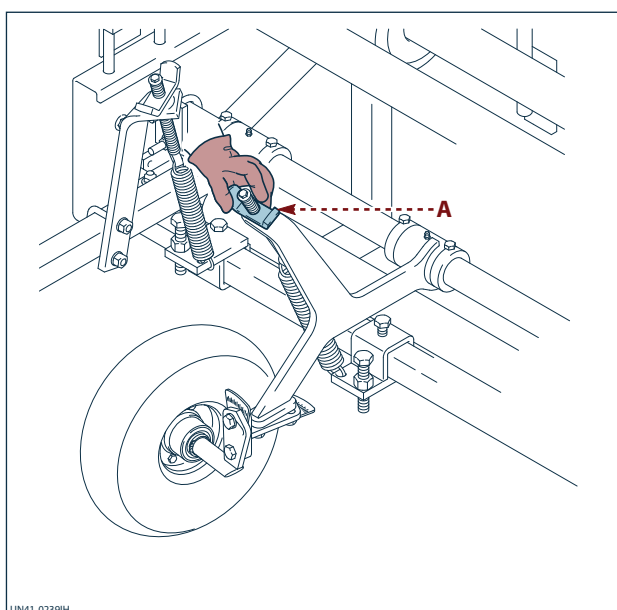

Adjusting the mulch sheet idle roller

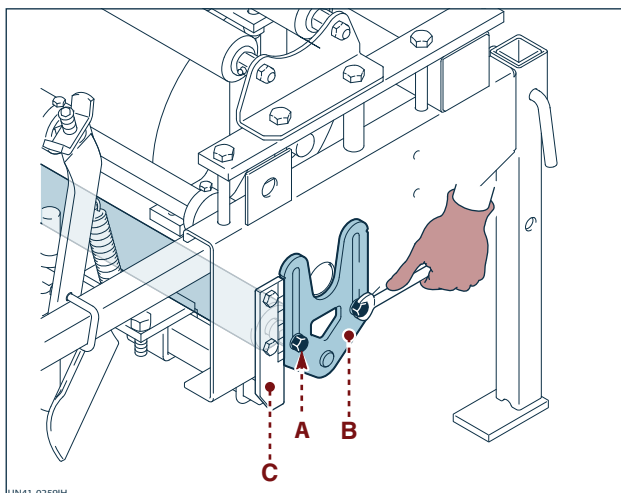

The idle roller height can be adjusted.

To adjust the idle roller, proceed as outlined below.

- 1) Loosen the screws **(A)** on both sides of the machine.
- 2) Lower the idle roller evenly on both sides and keep the supports **(B)** against the guides **(C)** to ensure proper mulch sheet unrolling.
- 3) Tighten the screws **(A)** on both sides of the machine.

Adjusting the mulch sheet unrolling tension

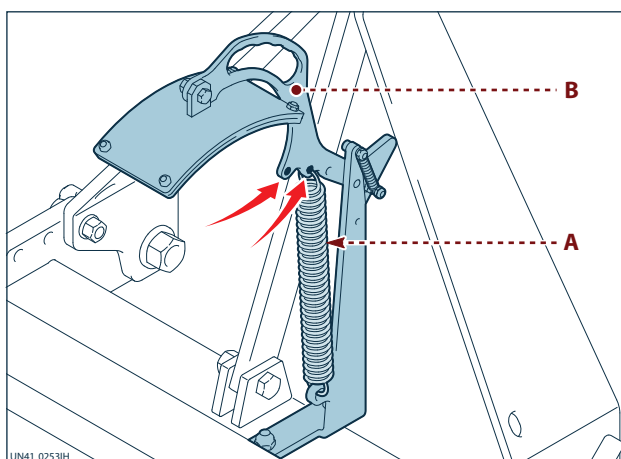

To adjust the mulch sheet unrolling tension, proceed as outlined below.

- 1) Release the spring **(A)** from the tensioning device **(B)** and insert it into one of the holes provided.



Information

Adjust the unrolling tension to suit the characteristics of the mulch sheet used and weather conditions (hot, cold, etc.).

Adjusting the front support wheels

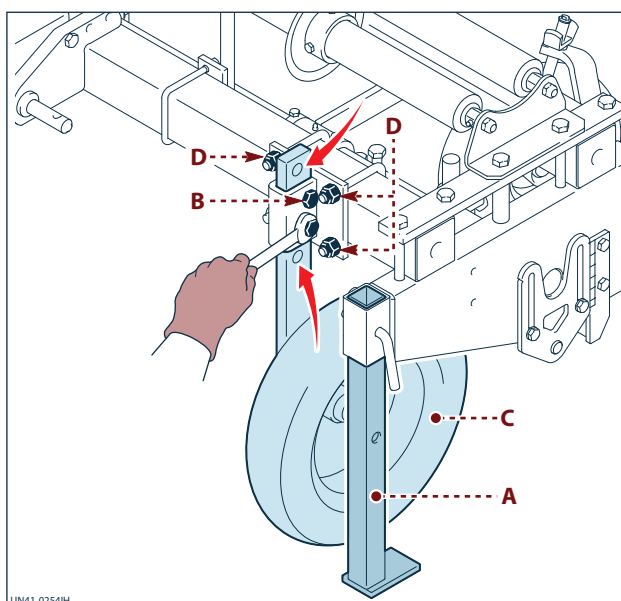

The support wheels are used to support the work vehicle and keep it horizontal during work.

The support wheels are mounted on the work vehicle as an alternative to the compacting roller.

To adjust the support wheels, proceed as outlined below.

- 1) Lower the feet **(A)** to prop up the machine.
- 2) Unscrew the screws **(D)** and position the work vehicle's support wheel aligned with the tractor's wheels.
- 3) Tighten the screws **(D)**.
- 4) Unscrew the screws **(B)** until the wheel is released.
- 5) Raise or lower the wheel as required.
- 6) Choose the knockouts on the support **(C)** near the required height and tighten the screws **(B)** aligned with the holes.
 - Repeat the same procedure for the other wheel.
 - Position the support wheels so that the mulch sheet idle roller is at least 10-15 cm away from the ground during work.
- 7) Lift the feet **(A)** off the ground.

Safety advice concerning use

To prevent the risk of injury, read the safety instructions given in section "3" carefully.

This ensures the machine can only be used by fit and healthy personnel, who are suitably trained and authorised, and hold the appropriate category driving licence for a tractor.

The tractor driver is responsible for assessing the hazards associated with envisaged environmental conditions, e.g., specific ground conditions (loose soil, slippery, sloping ground, etc..) which require special precautions, and it is up to the driver to take the necessary measures to eliminate or reduce these hazards.

Make sure nobody and no animals are in the machine work and manoeuvring area.

Before transiting on public roads, check that the tractor/work vehicle assembly complies with highway code regulations.

With combined machines (mulching machine coupled to planting machine), make particularly sure that the load on the tractor's front axle is sufficient to ensure good, constant driving stability, both during travel on the road and during work.

For use of a planting machine, please see the specific "Operation and Maintenance" manual supplied with the planting machine.

Hitching and unhitching the work vehicle to and from the tractor



Danger - Warning

Hitching the work vehicle up to the tractor is one of the riskiest moments as it could required the involvement of several people at once, carrying out synchronised manoeuvres between the tractor driver and the operators on the ground, which - if badly organised - could result in accidents.

The work vehicle must only ever be coupled to a tractor with an appropriate power rating which is equipped with a lift that complies with the regulations in force, observing the maximum weight limit on the rear axle and the gross vehicle weight (see tractor user manual).

Assess whether ballast is required at the front of the tractor to prevent it rearing up and losing stability during driving.

Check that the work vehicle coupling to the tractor at the third point of the hitch is securely locked so that it cannot work loose.

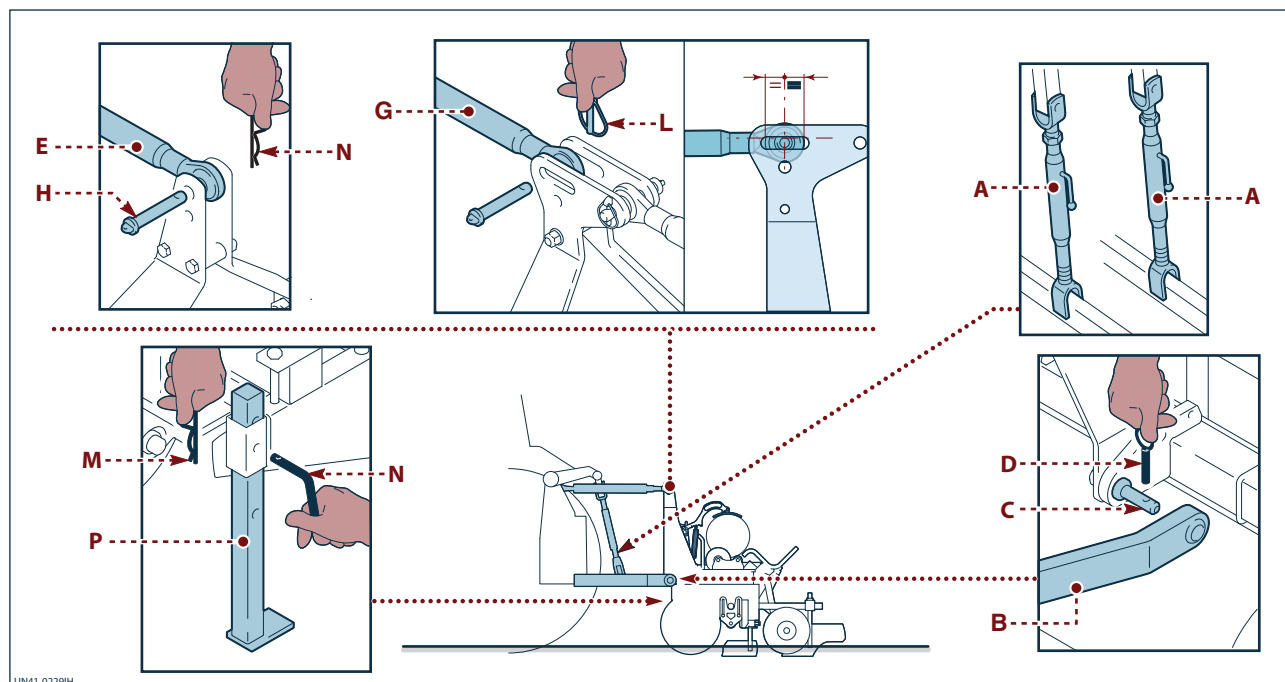

- For hitching, proceed as outlined below.

- 1) Position the work vehicle on flat, solid ground in a risk-free area.
- 2) Move the tractor so that it is positioned near the work vehicle lift frame.
- 3) Align the arms of the lifting unit with the coupling points on the work vehicle.
- 4) Switch off the tractor engine, remove the ignition key, and store it.

- 5) Turn the tie rods (**A**) to adjust the height of the lift arms (**B**) (see tractor instruction manual).
- 6) Insert the pins (**C**) into the lift arms and fit in the lock pins (**D**).
- 7) Turn the tie rod (**E**) to adjust the space between the tie rod and the upper coupling (**F**) on the support frame.
If the work vehicle is connected to a planting machine, position the ball joint (**G**) in the middle of the slot (see figure) to offset irregular work vehicle movements caused by bumpy ground.
- 8) Insert the pin (**H**) and the lock pin (**L**).
- 9) Remove the safety lock pin (**M**), slide out pin (**N**), and lift the resting foot (**P**) off the ground.
- 10) Adjust the tie rod (**E**) so that the work vehicle is parallel with the ground.

- **For unhitching, proceed as outlined below.**

- 1) Select an area with flat, solid ground to park the work vehicle - tractor.
- 2) Using the tractor's controls, lower the work vehicle to the ground.
- 3) Lower the resting foot (**P**), insert pin (**N**) and lock pin (**M**).
- 4) Switch off the tractor engine and remove the ignition key from the dashboard.
- 5) Take out the lock pin (**L**) and remove the pin (**H**).
- 6) Slide out the lock pins (**D**) and remove the lift arms (**B**) from the work vehicle's support frame.

Mulch sheet laying procedure

The mulch sheet must be laid on soil which has been sufficiently crushed and levelled and properly prepared with a harrow or cultivator.

Do not lay the mulch sheet on ground that is overly damp.

The version equipped with compacting roller makes the soil slightly compact and ensures proper mulch sheet laying.

The version equipped with front support wheels is only recommended when laying the mulch sheet on carefully levelled and compacted soils.

To lay the mulch sheet on the ground, proceed as outlined below.

- 1) Position the machine lengthways on the stretch of ground to cover with the plastic mulch sheet.
- 2) Unroll the roll (**A**), following the route of the mulch sheet, as shown in the figure.
- 3) Lower the mulch sheet tensioning device (**B**).
- 4) Using the tractor's controls, lower the work vehicle to the ground.
- 5) With the mulch sheet held on the ground, drive the work vehicle forwards a few metres.
- 6) Stop the machine and perform the checks described.
 - Check that the hoeing shares are properly positioned (see "Adjusting the hoeing shares").
 - Check that the ridging shares are properly positioned (see "Adjusting the ridging shares").
 - Check that the pressure wheels are properly positioned (see "Adjusting the plastic mulch sheet pressure wheels").

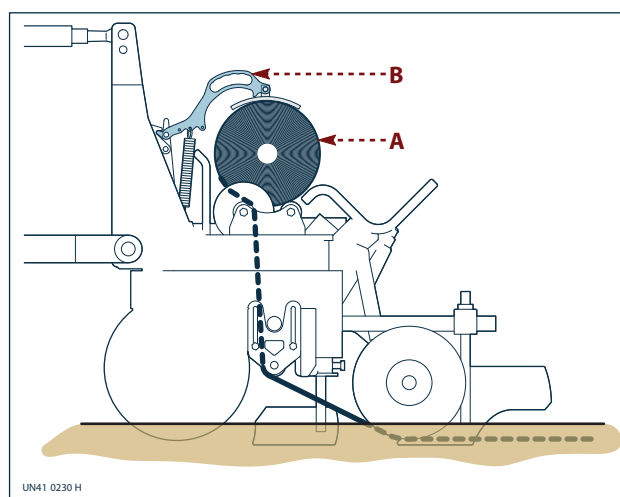

- Check that the mulch sheet idle roller is the right distance off the ground (see "Adjusting the plastic mulch sheet idle roller").
 - Check that the support wheels - if featured - are properly positioned (see "Adjusting the front support wheels").
 - Check that the mulch sheet is properly tensioned when unrolling (see "Adjusting the mulch sheet unrolling tension").
- 7) Drive the work vehicle forwards slowly, checking regularly that the mulch sheet is properly laid; if necessary, make the appropriate corrective measures.
When laying, do not reverse the tractor, as this could damage the work vehicle.
 - 8) Upon completing a laying stretch, cut the mulch sheet before beginning a new stretch.

Loading the roll of mulch sheet

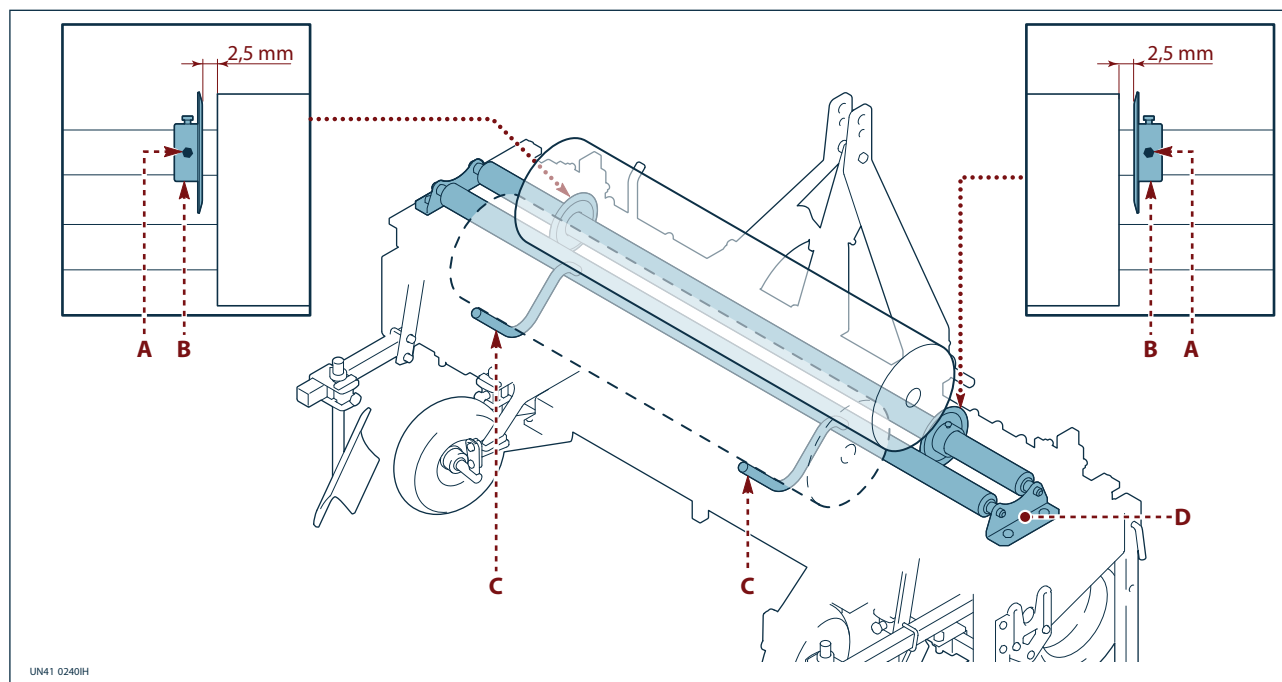

To load the roll, proceed as outlined below.

- 1) Loosen the screws (**A**).
- 2) Spread out the disks (**B**) so that they are farther apart than the width of the roll.
- 3) Lift and place the roll on the roller holder (**D**).
- 4) Position the roll in the centre of the work vehicle.
- 5) Move the disks (**B**) towards the roll, maintaining the distance shown in the figure.
- 6) Tighten the screws (**A**).

A spare roll can be loaded on the supports (**C**) for when the roll in use ends during laying.

Forming a seedbed or planting bed

Seedbeds or planting beds can be formed using the raised bed former with the shaping roller. For information on adjustment, see "Raised bed former and shaping roller" in the Attachments section.

Night-time work or poor visibility conditions

Working at night or in poor visibility conditions increases the risks arising from machine use; in these conditions, proper lighting must be provided to ensure safe work.

Transporting the work vehicle



Danger - Warning

For work unit loading/unloading, use lifting equipment with a suitable capacity for the load to be lifted. Use all possible caution when lifting to avoid damaging the work unit and causing injuries to persons involved in operations.

- Strap up the unit at the lifting points envisaged by the manufacturer.
- See the strap-up points and lifting procedures in the sections titled "Lifting the work unit" on page 10.
- Lower the support feet onto the bed of the means of transport.
- Anchor the work unit to the means of transport with ropes and secure the wheels with wedges.

The work vehicle, coupled to the tractor, can be loaded via ramps onto suitable means of transportation and then transported.



Danger - Warning

Thoroughly clean the ramps and loading platform before boarding the vehicle.

Position the ramps on the transport means and fix them in a stable way to the truck bed using the fastening devices (pins, screws, chain etc.).

Where the ramps meet the truck bed there is a dangerous bump so move the machine very carefully over this point.

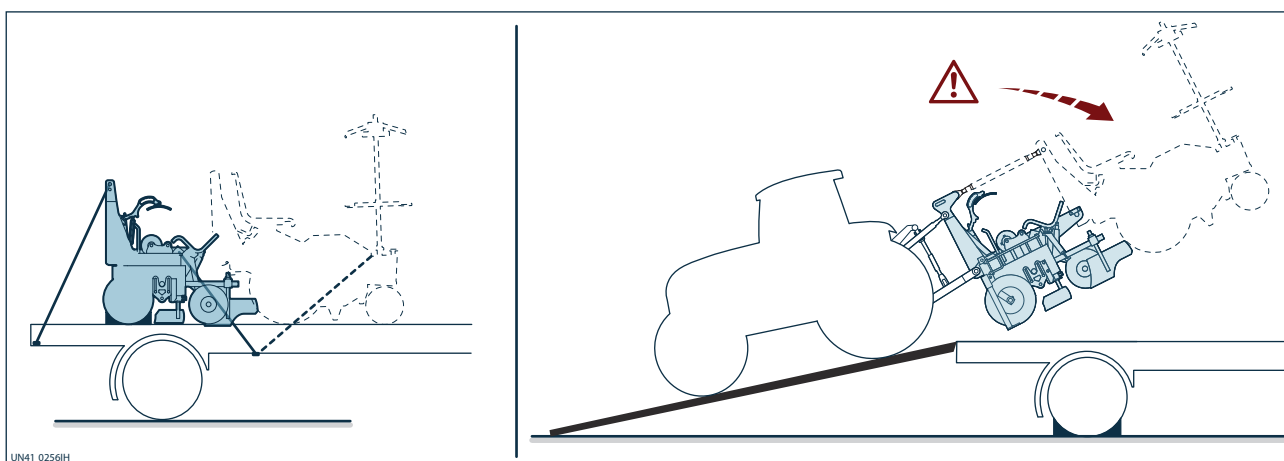

To load the work vehicle onto the means of transport, proceed as follows.

- 1) Board the means of transport, as shown in the figure, travelling at low speed.
- 2) Off the tractor engine and engage the parking brake.

- 3) Anchor the work unit-tractor assembly to the means of transport with ropes and secure the wheels with wedges.
- 4) Affix the relative signalling signs to any parts jutting out from the means of transport.

Transit on public roads



Danger - Warning

It is prohibited to carry people and/or things on the work vehicle.

Before embarking on the road, remove the mulch sheet roll from the work vehicle and clean any remaining soil off the tyres and components.

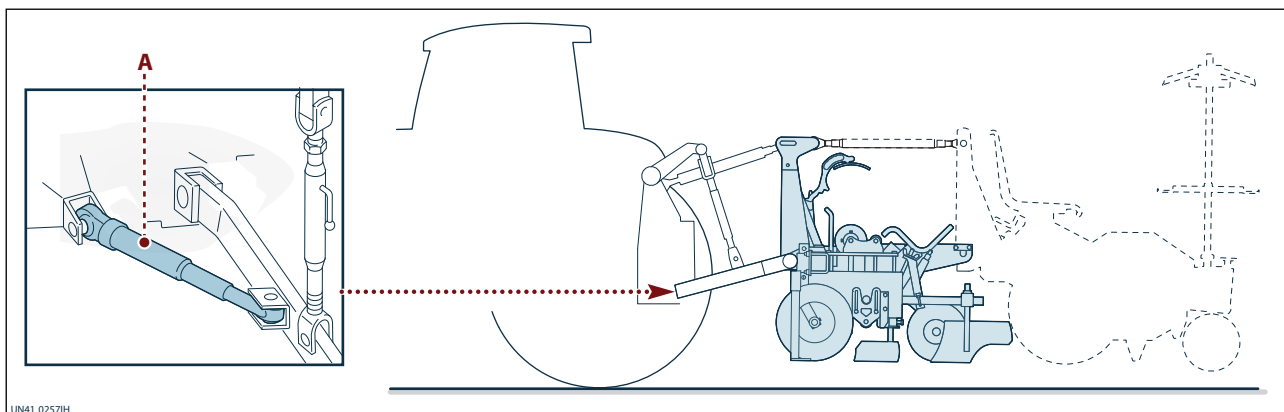

When transporting the work vehicle/tractor assembly, the regulations of the highway code must always be complied with.

The three-point hitch must be secured with the relative bars (A) to prevent the work vehicle swinging against the tractor and the speed of travel must be adjusted to prevent loss of control of the tractor.

Procedure for using the mulching machine combined with the planting machine

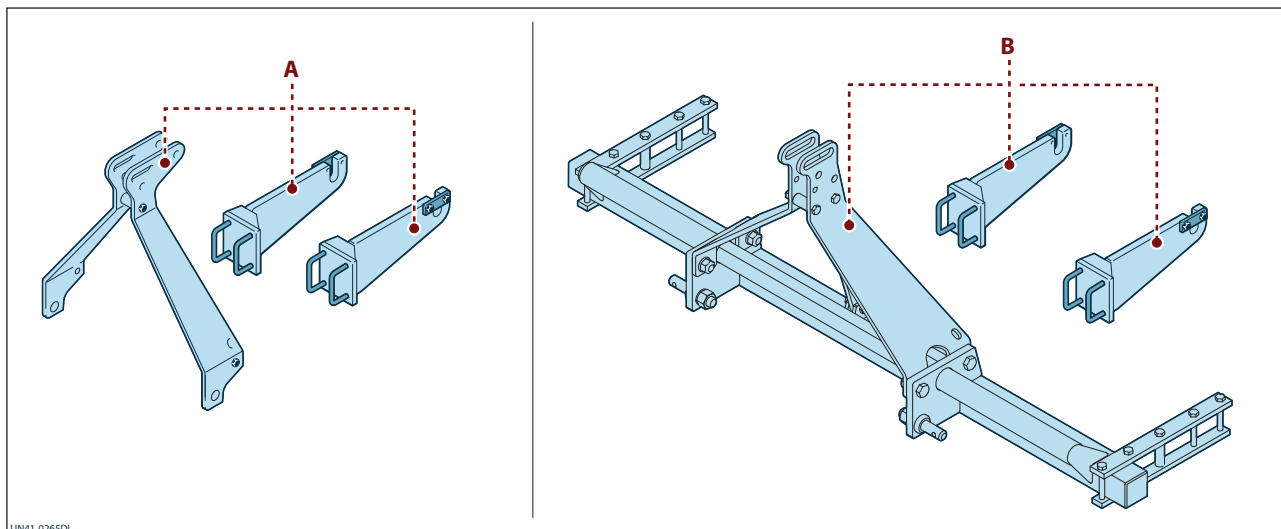

The mulching machine can be coupled to a WOLF planting machine using a specific kit for attachment to the rear 3-point hitch or using the reinforced frame kit. The rear hitch kit or reinforced frame kit can be supplied already mounted on the machine or as an optional accessory later.

The kit for attaching to the rear 3-point hitch (A) must be compulsory mounted on the mulching machines when they are combined with WOLF/1 and WOLF/2 planting machines.

The reinforced frame kit (B) must be compulsory mounted on the mulching machines when they are combined

with WOLF/3 and WOLF/4 planting machines. For use of a planting machine, please see the specific "Operation and Maintenance" manual supplied with the planting machine.



Danger - Warning

Only ever couple the mulching machine to the planting machines envisaged by the manufacturer (see "Technical specifications - Planting machines that can be coupled to the machine").

Prolonged disuse of the work vehicle

If the work vehicle is not due to be used for long periods, proceed as follows.

- 1) Clean the machine thoroughly, taking care to remove any chemical or fertiliser residues (see "Cleaning the work vehicle").
- 2) Check the condition of the all the machine's parts and replace any that are worn or damaged.
- 3) Check that the main fixing nuts and bolts are tight.
- 4) Grease to all the unpainted parts.
- 5) Grease the parts that require lubrication (see "Lubrication points diagram").
- 6) Park the machine carefully on flat ground in a dry area protected from the weather. Leave enough room around the work vehicle for the hitching up and unhitching manoeuvres.
- 7) Lower the resting feet to the ground to guarantee work vehicle stability.

Safety advice for maintenance

Maintenance work must be carried out with the work vehicle on flat, compact ground, with the tractor engine off, parking brake engaged, and ignition key removed, and adopting all the necessary safety measures required to work safely.

Any maintenance operations that can be carried out on the business premises come under the ordinary

maintenance envisaged in the instruction manual. Special maintenance operations (non included in this handbook) require a specialised workshop on the premises which meets the requirements specified by the relative laws in force (appropriate equipment suitably trained staff etc.); if you do not have a compliant workshop, contact an authorised one.

Maintenance interval schedule

To guarantee constant, efficient and safe machine operation, ensure all the maintenance envisaged by the manufacturer is carried out.

Maintenance intervals			
Frequency	Component	Type of work	Manual reference
Every hour	Compacting roller	Cleaning	
	Hoeing shares		
	Ridging shares		
	Pressure wheels	Greasing	
Every day	Lift frame	Inspection	Information and safety signs
	Warning and hazard plates	Inspection	
Every 25 hours	Pins for roll holder rollers	Greasing	Lubrication points diagram
	Pins for idle roller	Lubrication	
Every 50 hours	Machine components	Greasing	Lubrication points diagram
	Nuts and bolts	Tightening	
Every 150 hours	Tyres	Pressure check	Tyre check

Tyre check

Check the tyres for wear and if they feature tears or signs of ageing, they must be replaced.

Check tyre pressure and restore if necessary (see “Technical characteristics” schedule). The pressure must be checked with the work vehicle resting on the ground.

Cleaning the work vehicle

Clean the work vehicle with a high-pressure water jet and, if necessary, with approved detergents.

The liquid used for washing could be hazardous for the environment due to the presence of pollutants such as detergents, oils, etc., therefore do not simply dump the

wastewater; dispose of it in suitable areas equipped with separation devices for the pollutants.

Dry with compressed air and lubricate the components shown (see “Lubrication points diagram”).

Troubleshooting

The following list contains a number of common problems that may arise during work, together with the ways to solve them.

Fault	Likely cause	Solution	Reference
The mulch sheet rips or tears	The mulch sheet route is not correct	Correct the route	See "Mulch sheet laying procedure"
	The pressure wheels are not set properly	Adjust the pressure wheels	See "Adjusting the mulch sheet pressure wheels"
	The mulch sheet idle roller is not positioned correctly	Adjust the mulch sheet idle roller	See "Adjusting the mulch sheet idle roller"
	The mulch sheet unrolling tension is not correct	Adjust the mulch sheet unrolling tension	See "Adjusting the mulch sheet unrolling tension"
The mulch sheet lifts off the ground	The mulch sheet route is not correct	Correct the route	See "Mulch sheet laying procedure"
	The roll is not centred in relation to the hoeing shares or disks	Adjust the hoeing shares or disks	See "Adjusting the hoeing shares" or "Adjusting the hoeing disks"
	The pressure wheels are not set properly	Adjust the pressure wheels	See "Adjusting the mulch sheet pressure wheels"
	The hoeing shares or disks are not set properly	Adjust the hoeing shares or disks	See "Adjusting the hoeing shares" or "Adjusting the hoeing disks"
	The ridging shares or disks are not set properly	Adjust the ridging shares or disks	See "Adjusting the ridging shares" or "Adjusting the ridging disks"
	The mulch sheet idle roller is not positioned correctly	Adjust the mulch sheet idle roller	See "Adjusting the mulch sheet idle roller"
	The front support wheels (if featured) are not set properly	Adjust the front support wheels	See "Adjusting the front support wheels"
	The mulch sheet unrolling tension is not correct	Adjust the mulch sheet unrolling tension	See "Adjusting the mulch sheet unrolling tension"
The hosepipe is not lying properly	The hosepipe route is not correct	Correct the hosepipe route	See "Irrigation hosepipe" or "Irrigation hosepipe laying attachment"
	The hosepipe unreeling tension is not correct	Adjust the unreeling tension	See "Irrigation hosepipe"

Lubrication points diagram

Lubricate the parts shown at the times and in the ways specified.

Before lubricating, clean the components concerned and the greasing nipples to prevent contamination of

the lubricant.

Use universal grease for traction in farming and industrial machinery, which is water-repellent with a 180° drop point.

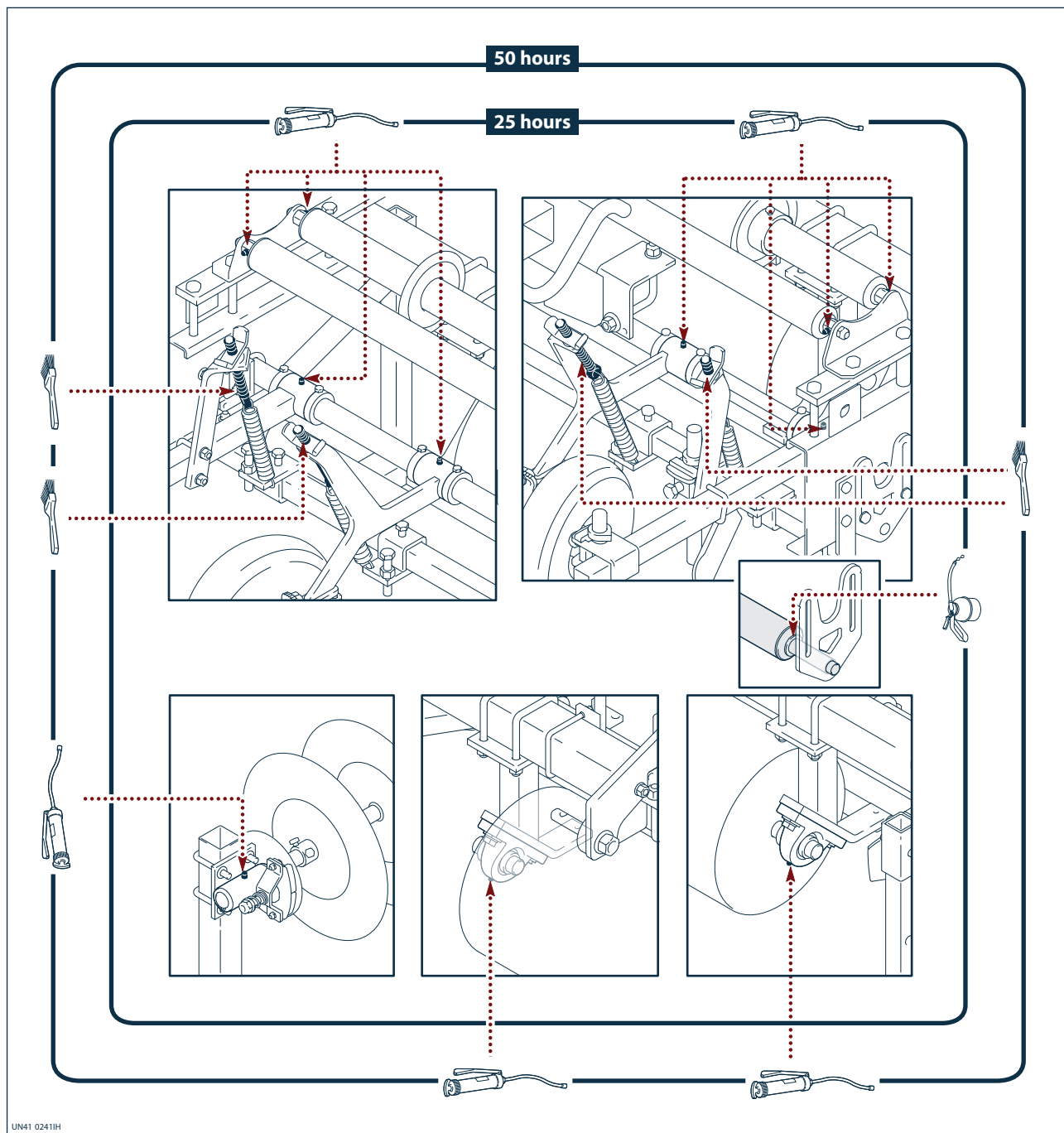

Grease	Grease	Oil
--------	--------	-----

UN41 0102HA

Scrapping the work vehicle

Adopt suitable safety measures to protect the personnel directly involved in the scrapping operations.

The person authorised to scrap the machine will have to dismantle and separate the components according to the type of constituent material and dispose of them separately, in accordance with applicable laws.

Do not dump non-biodegradable products, lubricants, and non-ferrous materials (rubber, PVC, resins, etc..).

Optional accessories

This section outlines the installation and features of certain accessories that can be supplied after delivery of the machine.

To ensure the safety of personnel, carefully read and follow the safety instructions given in section "3", as well as applicable safety in the workplace laws.



Danger - Warning

Dismantling and assembly operations must be carried out using suitable tools, by authorised personnel with the necessary skills required for the job in hand.

Take all the precautions required to work safely.

Kit for rear 3-point hitching

The rear three-point hitch is suitable for coupling the work vehicle to WOLF/1 and WOLF/2 planting machines.



Danger - Warning

Only ever couple the mulching machine to the planting machines envisaged by the manufacturer (see "Technical specifications - Planting machines that can be coupled to the machine").

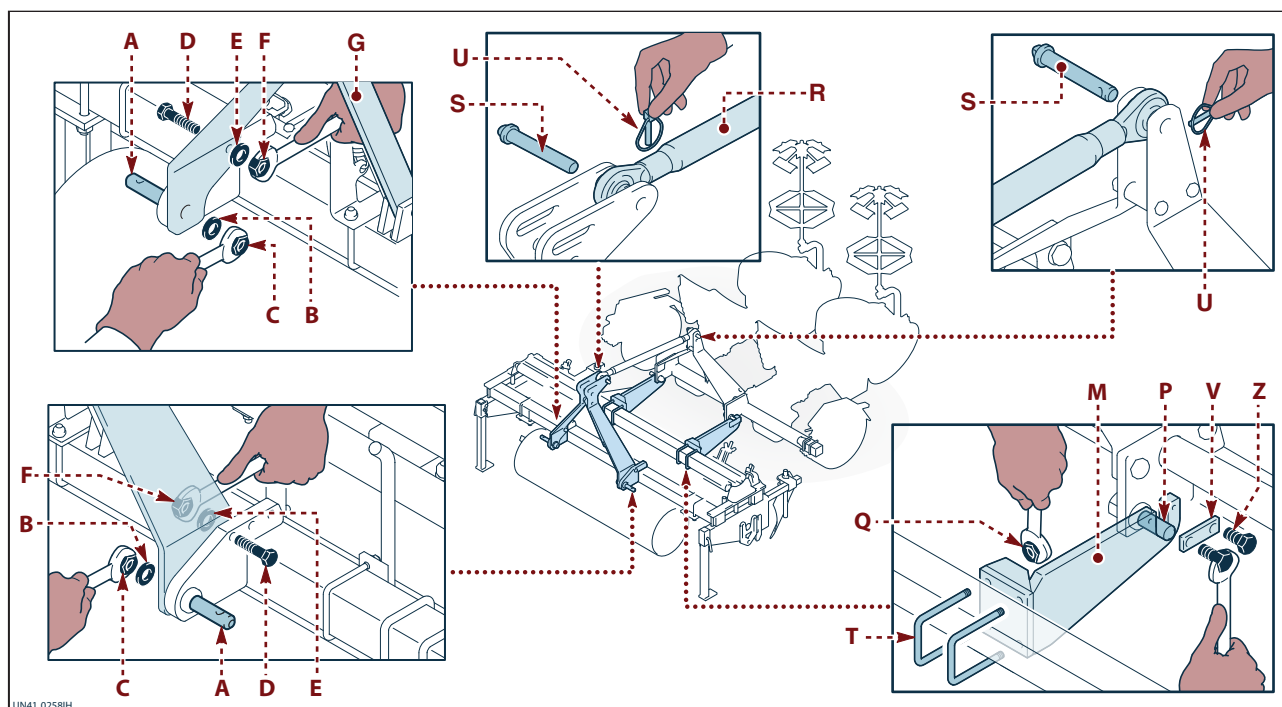

To assemble the support structure, proceed as outlined below.

- 1) Lower the structure onto the work vehicle.
- 2) Fit the tie rod (G)
- 3) Insert the pins (A).
- 4) Insert the washers (B).
- 5) Tighten the nuts (C).
- 6) Insert the screws (D).
- 7) Insert the washers (E).
- 8) Tighten the nuts (F).
- 9) Position the planting machine supports (M) on the centre line of the machine.
- 10) Secure the supports to the machine with the U-bolts (T) and nuts (Q) supplied with the rear 3-point hitch.
- 11) Unscrew the screws (Z) and remove the plate (V) from both supports.
- 12) Lift the planting machine and insert the pins (P) in the supports (M).
- 13) Position the plate (V) and tighten the screws (Z) on both supports.
- 14) Fit the tie rod (R) as shown in the figure.
- 15) Insert the pins (S) and secure them with their lock pins (U).
- 16) Adjust the tie rod (R) to position the planting machine horizontal to the ground.

Reinforced frame kit

The reinforced frame kit is suitable for coupling the work vehicle to WOLF/3 and WOLF/4 planting machines.



Danger - Warning

Only ever couple the mulching machine to the planting machines envisaged by the manufacturer (see "Technical specifications - Planting machines that can be coupled to the machine").

- Removing the standard frame

To remove the standard frame, proceed as outlined below.

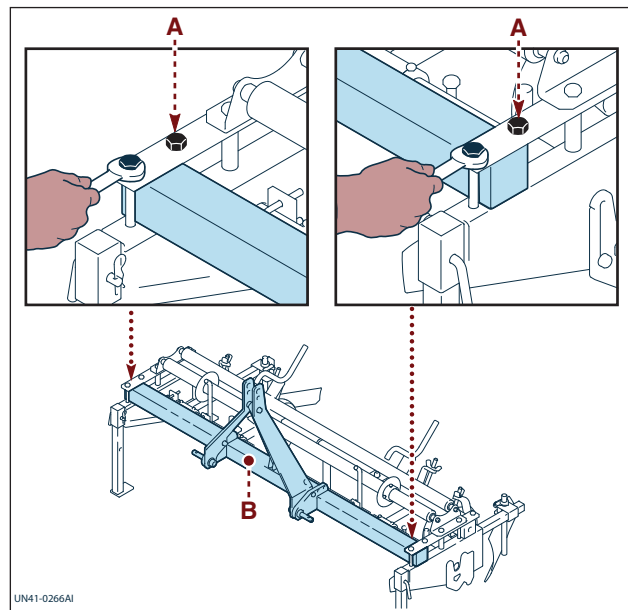
- 1) Remove all the components mounted on the standard frame (compacting roller, front support wheels, mulch sheet roll brake, etc.)
- 2) Undo the screws **(A)** on both sides of the work vehicle.
- 3) Remove the standard frame **(B)**.

- Reinforced frame kit assembly

To fit the reinforced frame, proceed as outlined below.

- 1) Position the reinforced frame **(1)**.
- 2) Position the brackets **(2)** and **(3)** as shown in the figure.
- 3) Tighten the screws **(4)**.
- 4) Tighten the screws **(5)**.

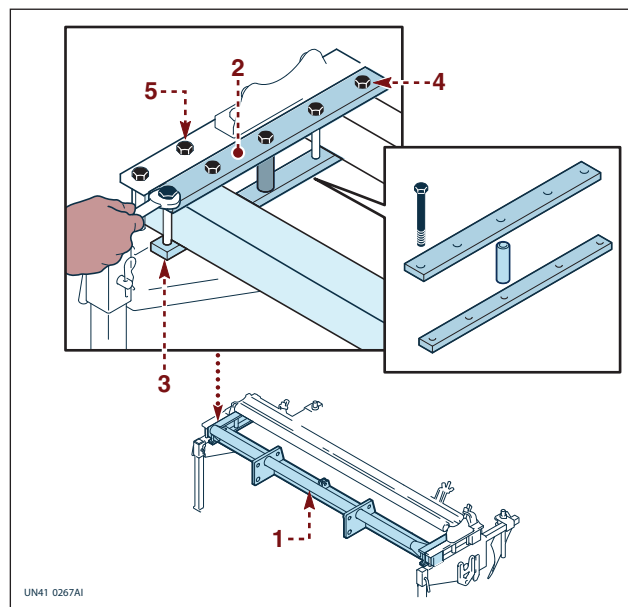

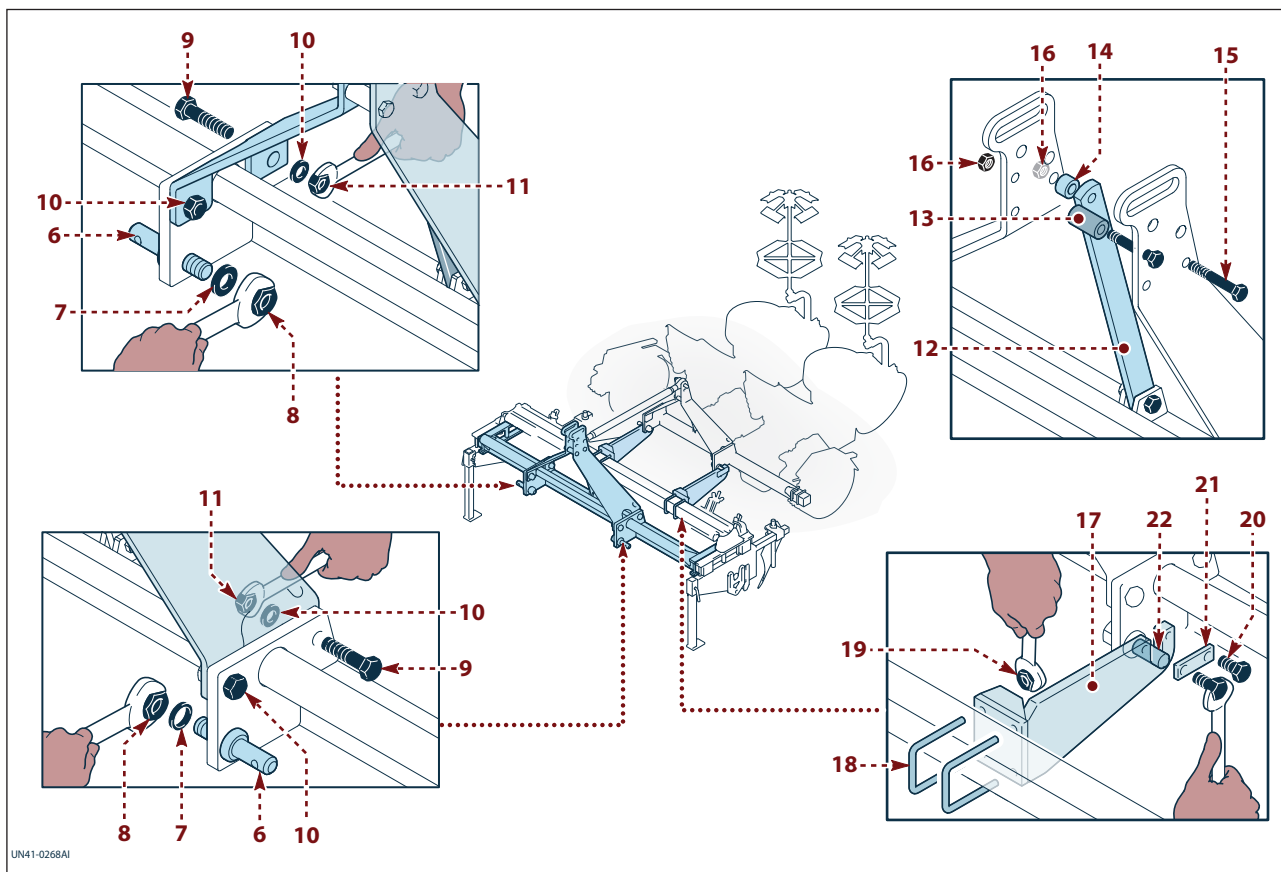

- 5) Insert the pins (6).
- 6) Insert the washers (7).
- 7) Tighten the nuts (8).
- 8) Insert the screws (9) and the washers (10).
- 9) Tighten the nuts (11).
- 10) Place the tie rod (12) as shown in the figure.
- 11) Place the bushings (13) and (14) in position.
- 12) Insert the screws (15).
- 13) Tighten the nuts (16).
- 14) Position the planting machine supports (17) on the centre line of the machine.
- 15) Secure the supports with the U-bolts (18) and nuts (19) supplied with the reinforced frame.
- 16) Unscrew the screws (20) and remove the plate (21) from both supports.
- 17) Lift the planting machine and insert the pins (22) in the supports (17).
- 18) Position the plate (21) and tighten the screws (20) on both supports.
- 19) Refit all the components originally mounted on the standard frame (compacting roller, front support wheels, mulch sheet roll brake, etc.).
- 20) Fit the tie rod (23) as shown in the figure.
- 21) Insert the pins (24) and secure them with their lock pins (25).
- 22) Adjust the tie rod (23) to position the planting machine horizontal to the ground.

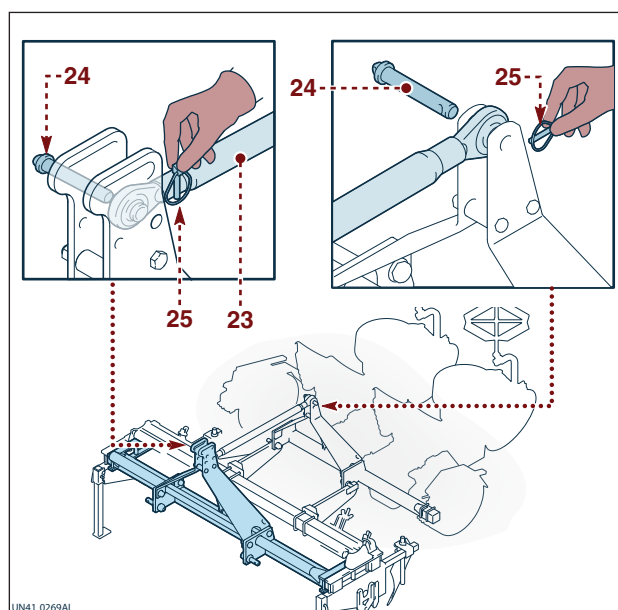

Irrigation hosepipe

The hosepipe is used to allow greater control when irrigating seedlings and also to spread fertilisers dissolved in water (fertigation).

The hosepipe is usually placed underneath the plastic mulch sheet, in the centre.

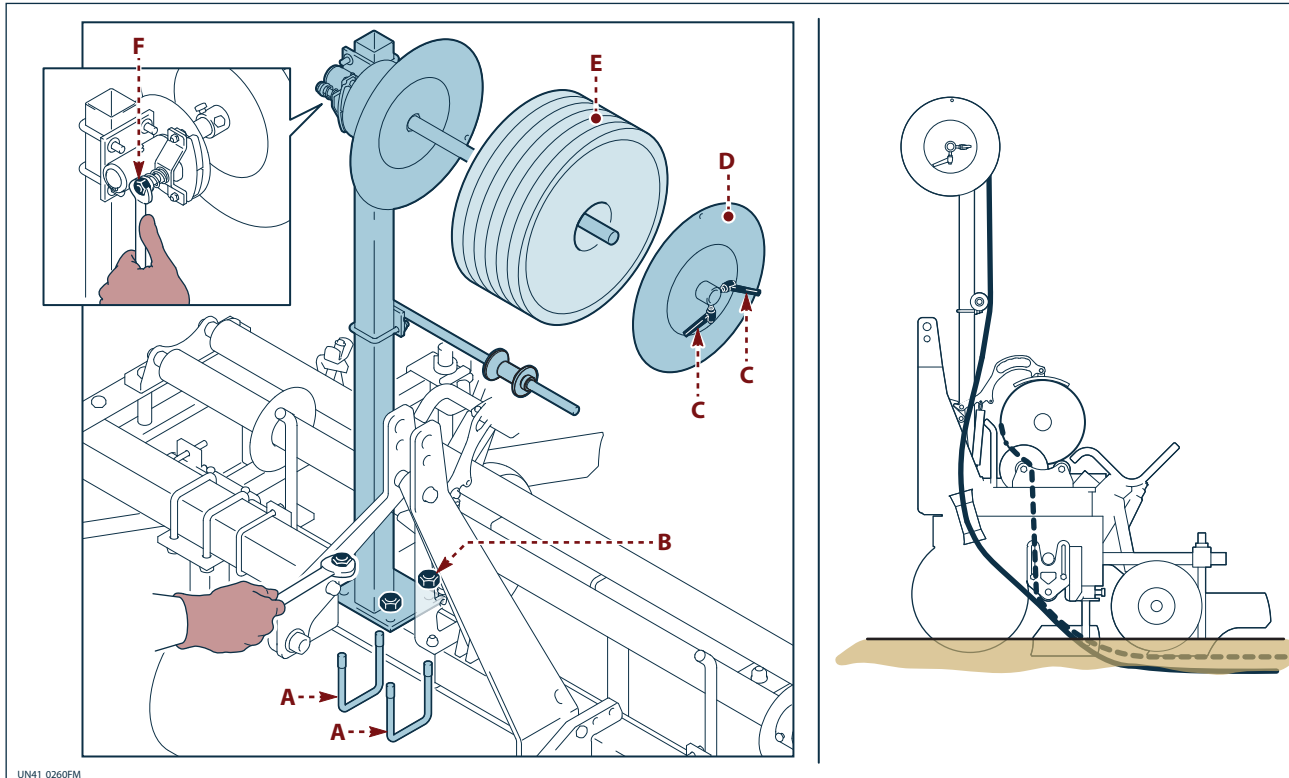

- Fitting the irrigation hosepipe holder

To fit the hosepipe, proceed as outlined below.

- 1) Position the hosepipe on the work vehicle.
- 2) Fit the U-bolts (**A**).
- 3) Tighten the nuts (**B**).

- Irrigation hosepipe reel housing and routing

- 1) Loosen the locking levers (**C**).
- 2) Remove the disk (**D**).
- 3) Fit the hosepipe onto the shaft (**E**).
- 4) Fit the disk (**D**) onto the shaft and tighten the locking levers (**C**).
- 5) Unwind the hosepipe, following the route shown in the figure.
- 6) Turn the nut (**F**), as required, to adjust the tension of the irrigation hosepipe.

Irrigation hosepipe laying attachment

The laying attachment is used to dig a furrow in the ground and lay the irrigation hosepipe inside it.

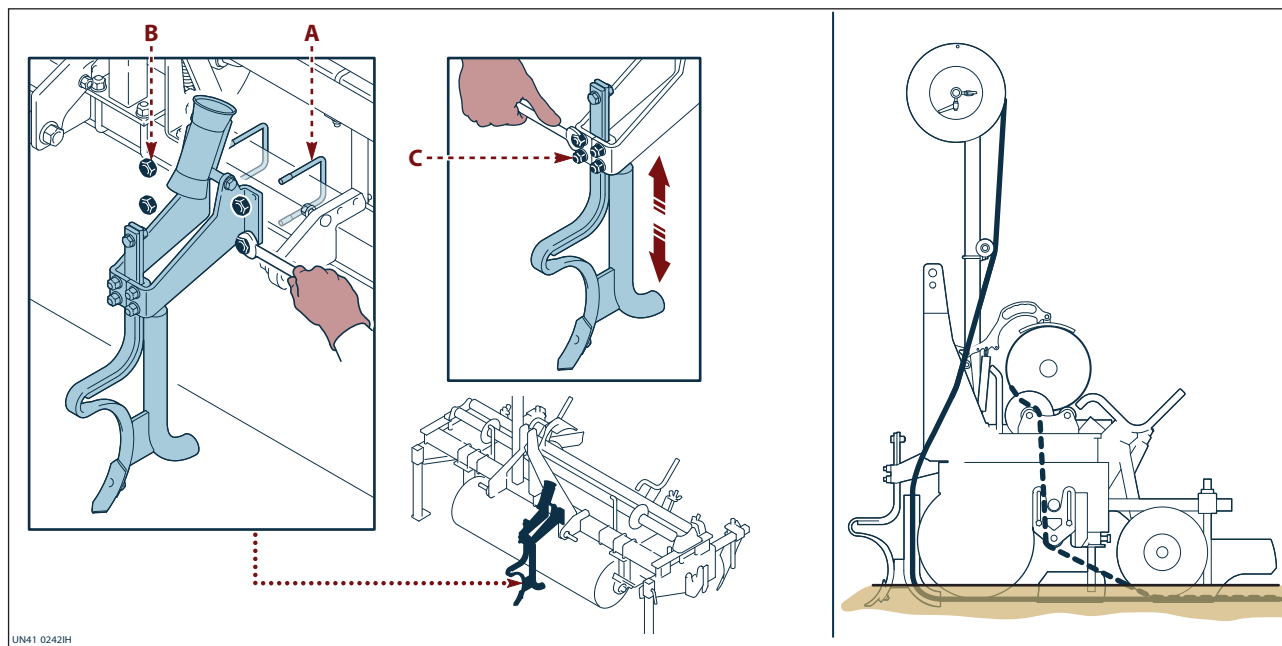

- Laying attachment assembly

- 1) Position the laying attachment on the work vehicle.
- 2) Fit the U-bolts (A).
- 3) Tighten the nuts (B).
- 4) Unwind the hosepipe, following the route shown in the figure.

- Adjust the laying attachment

To adjust the laying attachment, proceed as outlined below.

- 1) Loosen the nuts (C).
- 2) Raise or lower the laying attachment to alter the hosepipe laying depth.
- 3) Tighten the nuts (C).

Raised bed former and shaping roller

The raised bed former is used for shaping slightly raised seedbeds or planting beds and can be used in both mulching operations and seeding or planting operations in bare ground. The illustration shows the main parts of the raised bed former.

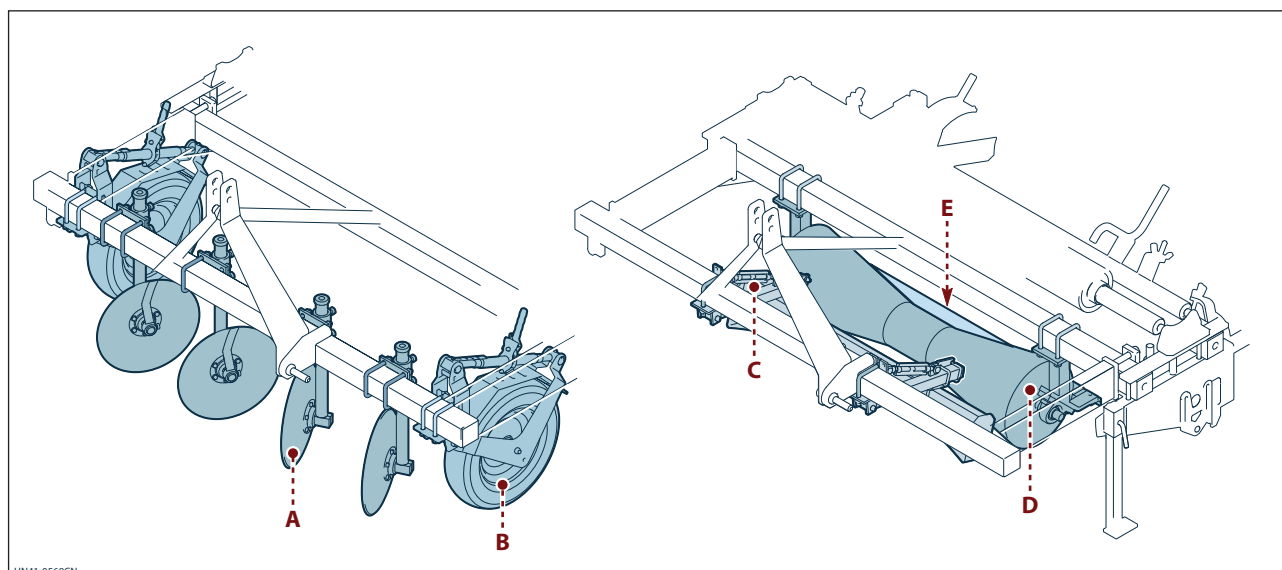

- A)** Conveying disk
- B)** Support wheel
- C)** Raised bed former

- D)** Shaping roller
- E)** Shaping roller scraper blade

- *Adjusting the conveying disks*

The conveying disks are used to convey the soil towards the raised bed former in order to form the mound for the seed bed or planting bed.

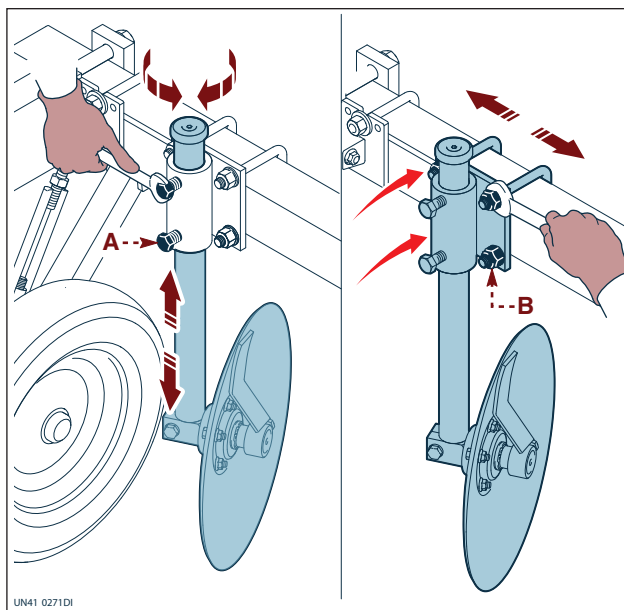

To adjust the disk, proceed as outlined below.

- 1) Loosen the screws (A).
- 2) Raise or lower the disk to increase or decrease the amount of soil needed to form the seedbed or planting bed.
- 3) Tighten the screws (A).
- 4) Loosen the screws (B).
- 5) Move the conveying disk unit as required.
- 6) Alter the inclination of the disks in order to spread the soil properly to form the seed bed or planting bed.
- 7) Tighten the screws (B).

Repeat the same procedure for the other disks.

- *Adjusting the raised bed former*

The raised bed former is used for pre-shaping the soil before the shaping roller is used, in order to form a seed bed or planting bed.

Adjust the raised bed former in order to accumulate enough soil in front of the shaping roller to create the furrow in the ground properly.

To adjust the raised bed former, proceed as outlined below.

- 1) Adjust the tie rods (A) with an appropriate tool.
 - Turn the tie rods clockwise to increase the amount of soil in front of the shaping roller.
 - Turn the tie rods anticlockwise to decrease the amount of soil in front of the shaping roller.

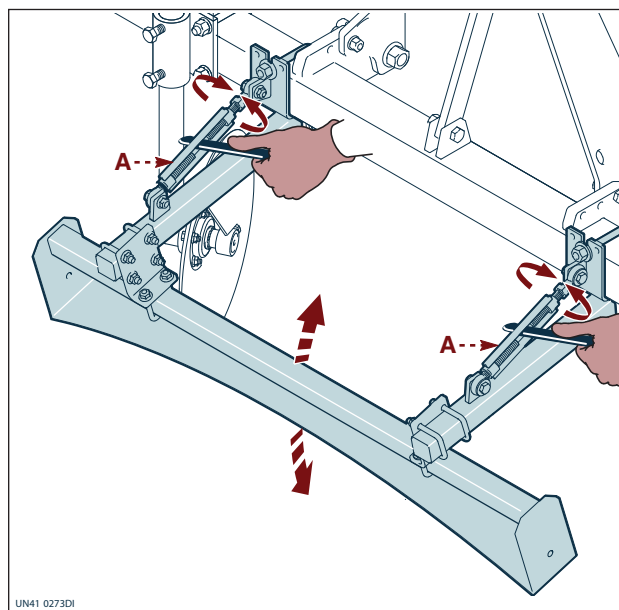

- *Adjusting the shaping roller*

The distance between the shaping roller and the ground is set by adjusting the support wheel and it also determines the depth of the furrow in the raised seed bed or planting bed (see page 4 "Technical Data").

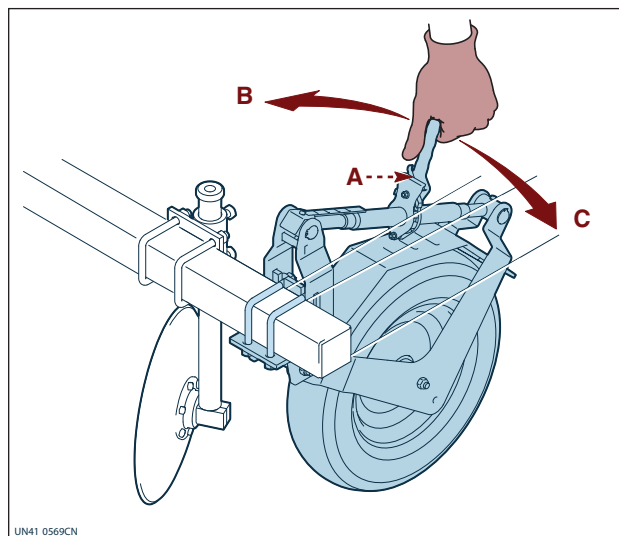

To adjust the shaping roller, proceed as outlined below.

- 1) Use the ratchet lever (A).
 - Turn the lever in the direction (B) to increase the shaping roller's height off the ground.
 - Turn the lever in the direction (C) to decrease the shaping roller's height off the ground.

Repeat the same procedure for the other support wheel.

i **Information**

After adjustment, check and if necessary readjust the conveying disks and raised bed former.



VIA GUIZZARDI, 38
40054 BUDRIO (BO) - ITALY
TEL. (051) 80.02.53 - FAX (051) 69.20.611
www.checchiemagli.com
info@checchiemagli.com